

DESCRIPTION

This manual aims to illustrate how to use the EP3003 Evaluation Board (“EP3003 EVB”).

The EP3003 EVB is a Dual Synchronous, 600mA, 1.5MHz Step-Down DC/DC Regulator featuring the EP3003. The EP3003 EVB has an input voltage range of 2.5V to 5.5V, and either output is capable of delivering up to 600mA of output current. In Burst Mode operation, the EP3003 requires only 50 uA of quiescent current, and the EP3003 EVB provides higher efficiency at light load currents. In Pulse Skip mode, the EP3003 EVB provides lower output ripple voltage at light load currents. In either mode, the EP3003 EVB can provide up to 96% efficiency on either channel and consumes less than 1uA in shutdown. The EP3003 comes in a small 10-Pin MS10E package, which has an exposed pad on the bottom-side of the IC for better thermal performance. These features, plus the nominal operating frequency of 1.5MHz (allowing the exclusive use of low profile surface mount components), make the EP3003 EVB an ideal circuit for use in battery-powered, hand-held applications.

This manual includes Quick Start for using the EP3003 EVB, Demonstration Circuit, PCB Layout and Bill of Material for the EP3003 EVB.

QUICK START

Demonstration circuit EP3003 EVB is easy to set up to evaluate the performance of the EP3003. Refer to Figure 1 for proper measurement equipment setup and follow the procedure below:

1. Connect the input power supply to the V_{IN} and GND terminals on the up-side of the board. Do not hot-plug V_{IN} or increase V_{IN} over the rated maximum supply voltage of 5.5V, or the part may be damaged. Connect the loads between the V_{OUT} and GND terminals on the right-side and left –side of the board. Refer to figure 1 for the proper measurement equipment setup.
2. Before proceeding to operation, jumper JP1 into the V_{OUT1} voltage position of choice (2.5V, 2.8V, and 3.3V), and JP2 into the V_{OUT2} voltage position of choice (1.2V, 1.5V, and 1.8V), and jumper JP3 into the desired mode of operation: Pulse Skip or Burst Mode.
3. Apply 3.3V at V_{IN} . Measure both V_{OUTS} ; they should read 0V. If desired, one can measure the shutdown supply current at this point. The supply current will be approximately 33 uA in shutdown, with roughly 32 uA due to the optional 100k Ω pull-up resistor of the Power-On Reset (POR) feature. This resistor can be removed, and the actual shutdown supply current can be measured, if the POR feature is not required.
4. Turn on V_{OUT1} and V_{OUT2} by changing jumpers JP1 and JP2 of choice voltages. Vary the input voltage from 2.5V to 5.5V and adjust each load current from 0 to 600mA. Both output voltages should be regulating.
5. Set the load current of both outputs between 200 mA and 600 mA, and measure both output ripple voltages; they should measure less than 20 mVAC each. Also, observe the voltage waveform at the switch node (pin 3) of each regulator. The switching frequencies should be between 1.2 MHz and 1.8 MHz ($T = 0.833 \mu s$ and $0.555 \mu s$), and each switch node waveform should be rectangular in shape.

6. To change the mode of operation, change jumpers JP1 and JP2 from the ON position(s) to the OFF position(s). Then change jumper JP3 to the alternative position. Re-insert jumpers JP1 and JP2 into the ON position(s). Observe the voltage waveform at both switch nodes.

When finished, don't forget disconnect the power.

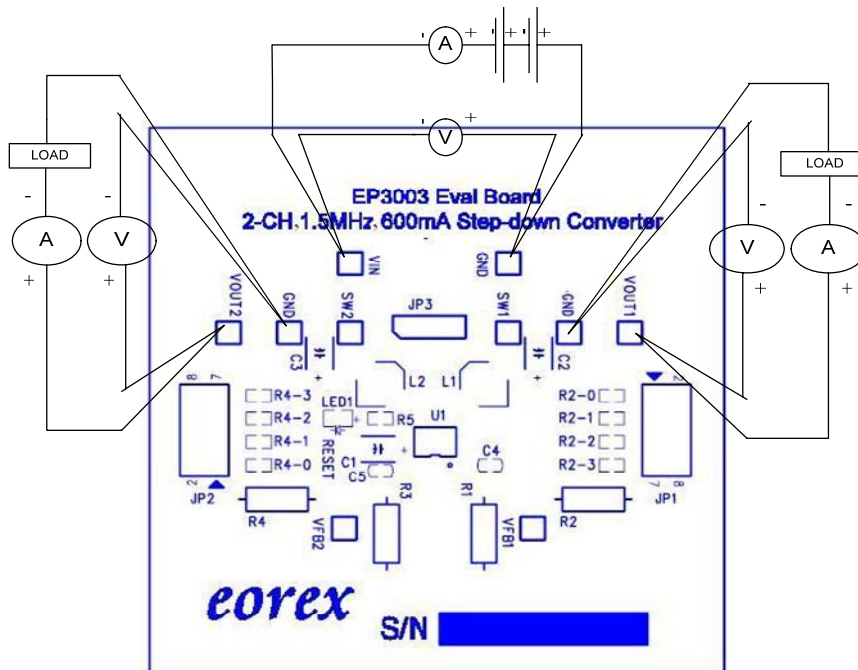

Figure 1. Proper Measurement Equipment Setup

Jump Setting

JUMPER	output voltage selection	
JP1	When AUX is selected please see the following section.	
JP2	When AUX is selected please see the following section.	
JUMPER	Jump to GND	Jump to V_{IN}
JP3	Pulse Skip	Burst Mode

Output Programming

The output programming resistors for adjustable type are listed in Table 1. If AUX with JP1 and JP2 is selected, please put on R2-3 and R4-0 according to the following equation:

$$V_{out} = 0.6V \left(1 + \frac{R2}{R1} \right)$$

Table 1 Output Programming Resistor

Vout (V)	R1 (KΩ)	R2 (KΩ)
1.2	100	R2-0 = 100
1.5	100	R2-1 = 150
1.8	100	R2-2 = 200
AUX	100	R2-3 = Function
2.5	240	R4-3 = 750
2.8	240	R4-2 = 910
3.3	240	R2-1 = 1100
AUX	240	R2-0 = Function

DEMONSTRATION CIRCUIT

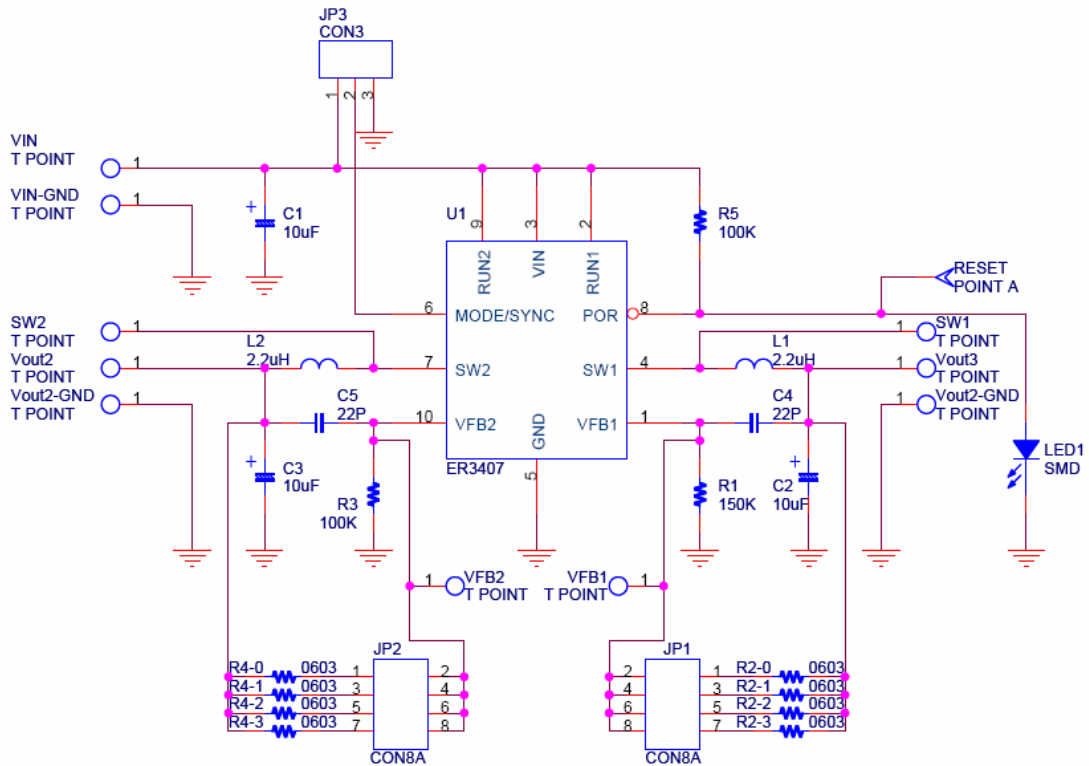

PCB LAYOUT

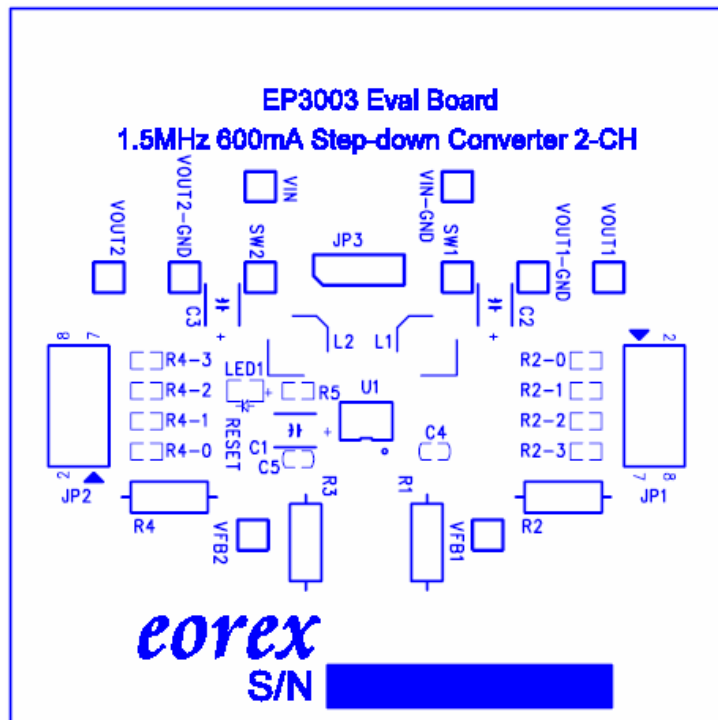

BILL OF MATERIAL

Item	Qty	Ref.	Part Description	Manufacture/Part No.	Note
1	1	U1	IC,EP3003,DFN-10	EP3003	
2	2	L1, L2	POWER INDUCTOR 2.2UH 1.75A SMD	C4-K1.8L	
3	3	C1, C2, C3	10uF, 106P Y5 10V	SMD 1206	
4	2	C4, C5	22pF, 22P±10 16V	SMD 0603	
5	1	R1	100K± 5%	AAC	
6	1	R2-0	100K± 5%	AAC	
7	1	R2-1	150K± 5%	AAC	
8	1	R2-2	200K± 5%	AAC	
9	1	R3	150K± 5%	AAC	
10	1	R4-1	750K± 5%	AAC	
11	1	R4-2	910K± 5%	AAC	
12	1	R4-3	1100K± 5%	AAC	