



EMIF02-MIC03F2

IPAD™

2 LINE EMI FILTER AND ESD PROTECTION

MAIN PRODUCT CHARACTERISTICS:

Where EMI filtering in ESD sensitive equipment is required :

- Mobile phones and communication systems
- Computers, printers and MCU Boards

DESCRIPTION

The EMIF02-MIC03 is a highly integrated device designed to suppress EMI/RFI noise in all systems subjected to electromagnetic interferences. The EMIF02 Flip-Chip packaging means the package size is equal to the die size.

This filter includes an ESD protection circuitry which prevents damage to the application when subjected to ESD surges up to 15 kV.

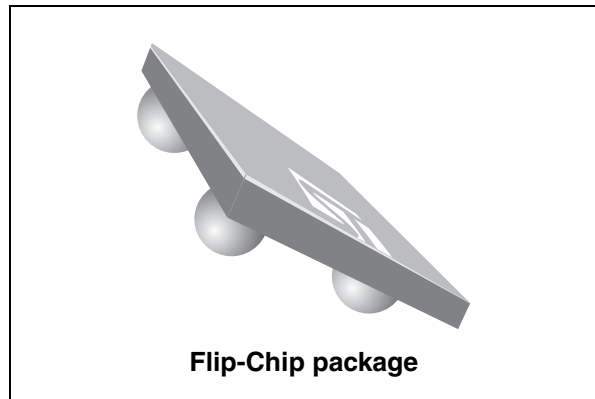

Flip-Chip package

BENEFITS

- EMI symmetrical (I/O) low-pass filter
- High efficiency in EMI filtering
- Very low PCB space consuming:
1.07 mm x 1.47 mm
- Very thin package: 0.65 mm
- High efficiency in ESD suppression
- High reliability offered by monolithic integration
- High reducing of parasitic elements through integration & wafer level packaging

COMPLIES WITH THE FOLLOWING STANDARDS: IEC 61000-4-2

- | | | |
|---------|----------------|--------------------------|
| Level 4 | on input pins | 15 kV (air discharge) |
| | | 8 kV (contact discharge) |
| Level 1 | on output pins | 2 kV (air discharge) |
| | | 2 kV (contact discharge) |

MIL STD 883E - Method 3015-6 Class 3

PIN CONFIGURATION (bump side)

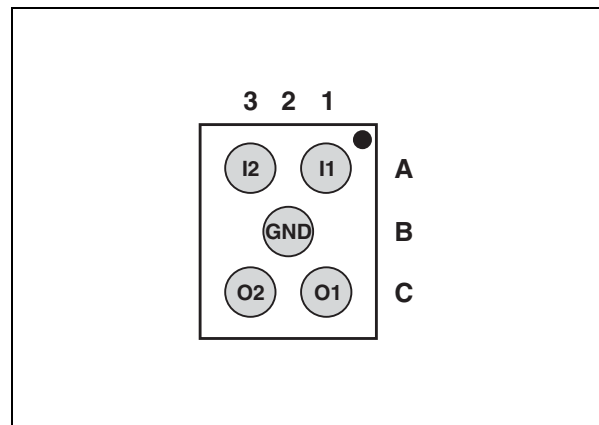

BASIC CELL CONFIGURATION

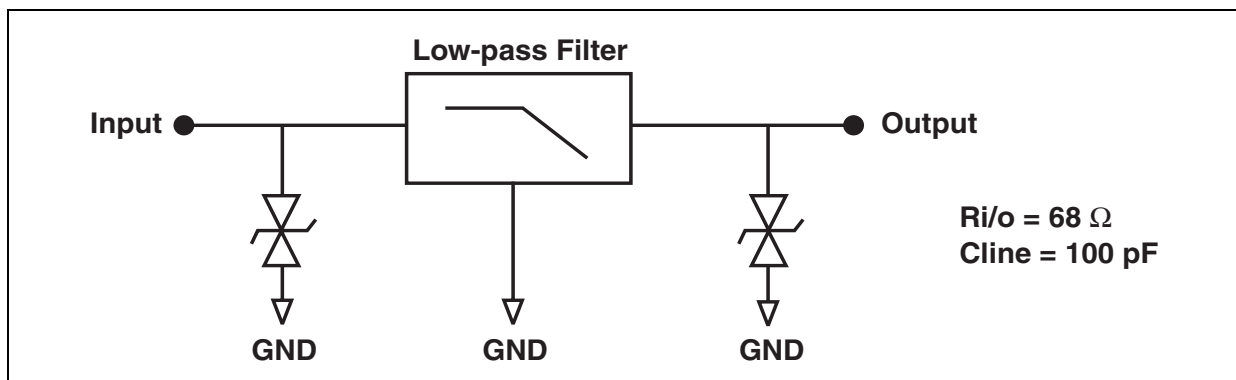

TM: IPAD is a trademark of STMicroelectronics.

ABSOLUTE RATINGS (limiting values)

Symbol	Parameter and test conditions	Value	Unit
T _j	Maximum junction temperature	125	°C
T _{op}	Operating temperature range	- 40 to + 85	°C
T _{stg}	Storage temperature range	- 55 to 150	°C

ELECTRICAL CHARACTERISTICS (T_{amb} = 25 °C)

Symbol	Parameter
V _{BR}	Breakdown voltage
I _{RM}	Leakage current @ V _{RM}
V _{RM}	Stand-off voltage
V _{CL}	Clamping voltage
R _d	Dynamic impedance
I _{PP}	Peak pulse current
R _{I/O}	Series resistance between Input & Output
C _{line}	Input capacitance per line

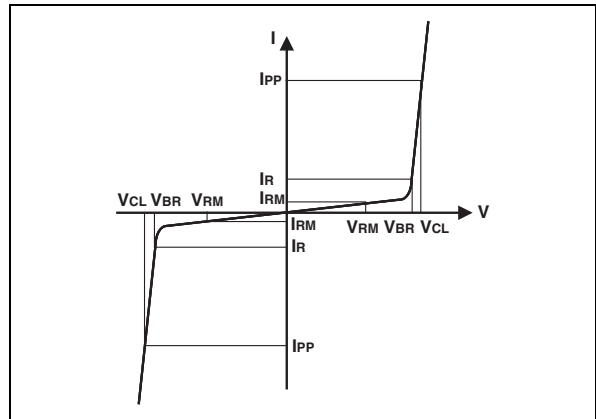

Symbol	Test conditions	Min.	Typ.	Max.	Unit
V _{BR}	I _R = 1 mA	6	8		V
I _{RM}	V _{RM} = 3 V per line			500	nA
R _{I/O}	Tolerance ± 20 %		68		Ω
C _{line}	V _R = 0 V		100		pF

Fig. 1: S21 (dB) attenuation measurements and Aplac simulation.

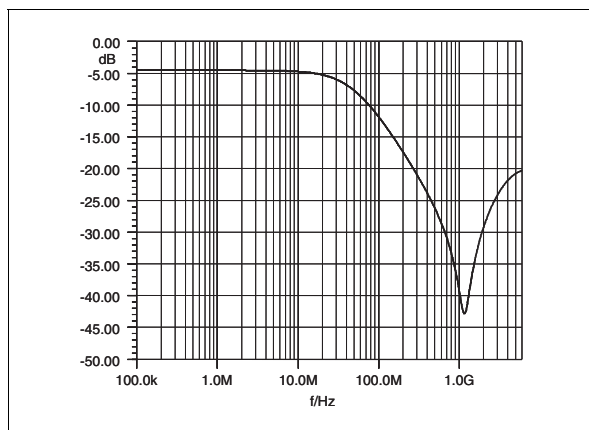

Fig. 2: Analog crosstalk measurements.

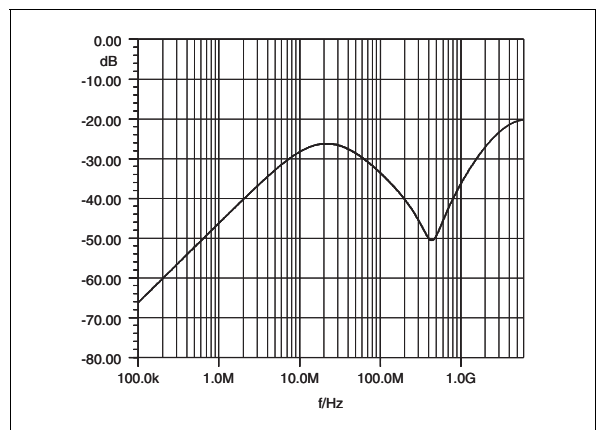

Fig. 3: ESD response to IEC61000-4-2 (+15kV air discharge) on one input V(in) and one output V(out).

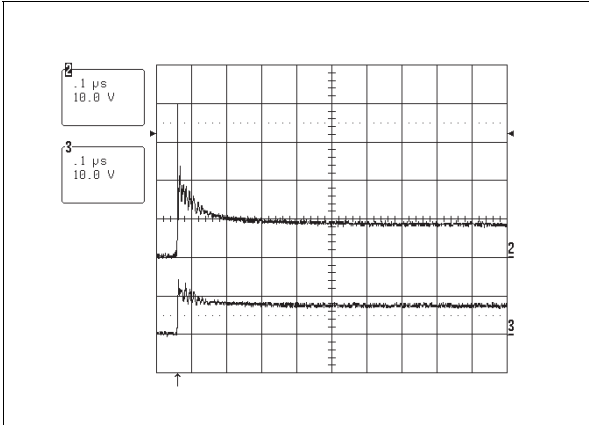

Fig. 4: ESD response to IEC61000-4-2 (-15kV air discharge) on one input V(in) and one output V(out).

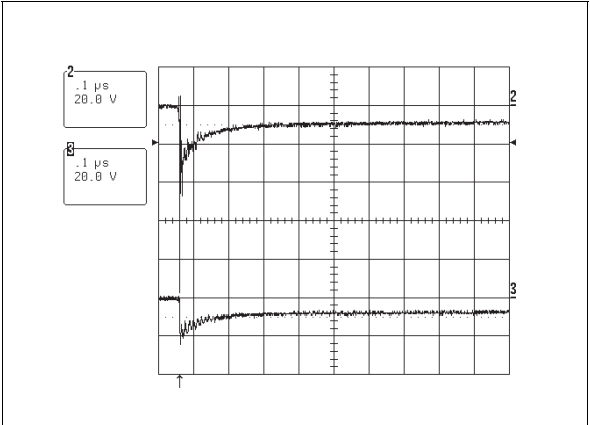
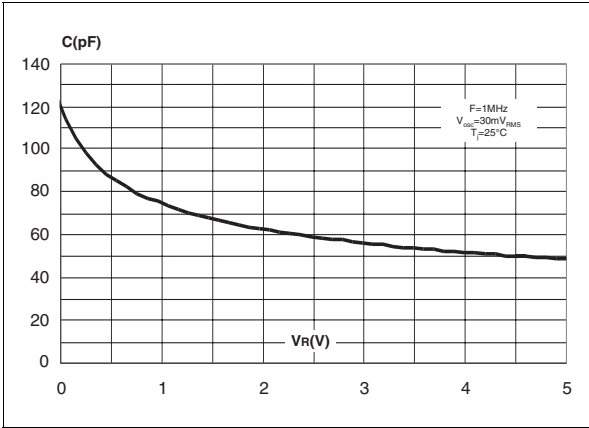
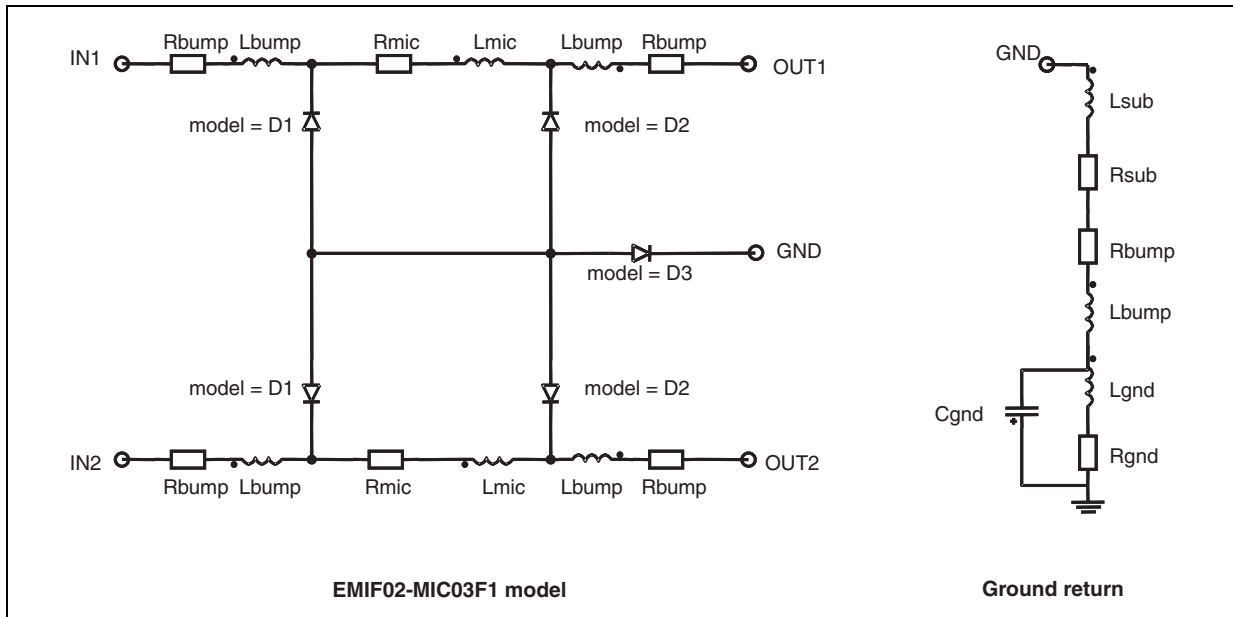

Fig. 5: Line capacitance versus applied voltage.



EMIF02-MIC03F2

Aplac model



Aplac parameters

Model D1	Model D3	Model D2	aplacvar Rmic 68
CJO=Cdiode1	CJO=Cdiode3	CJO=Cdiode2	aplacvar Lmic 10p
BV=7	BV=7	BV=7	aplacvar Cdiode1 100pF
IBV=1u	IBV=1u	IBV=1u	aplacvar Cdiode2 3.6pF
IKF=1000	IKF=1000	IKF=1000	aplacvar Cdiode3 1.17nF
IS=10f	IS=10f	IS=10f	aplacvar Lbump 50pH
ISR=100p	ISR=100p	ISR=100p	aplacvar Rbump 20m
N=1	N=1	N=1	aplacvar Rsub 0.5m
M=0.3333	M=0.3333	M=0.3333	aplacvar Rgnd 10m
RS=0.7	RS=0.12	RS=0.3	aplacvar Lgnd 50pH
VJ=0.6	VJ=0.6	VJ=0.6	aplacvar Cgnd 0.15pF
TT=50n	TT=50n	TT=50n	aplacvar Lsub 10pH

ORDER CODE

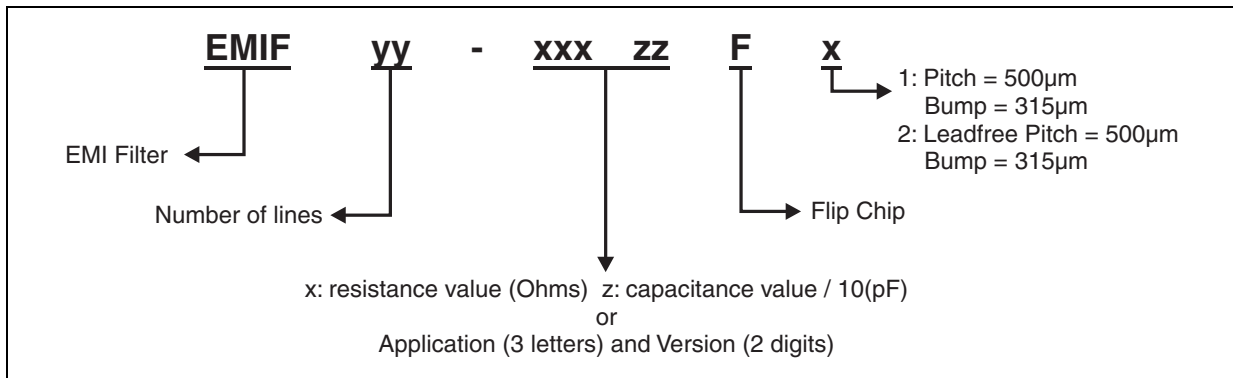

**PACKAGE MECHANICAL DATA
FLIP CHIP**

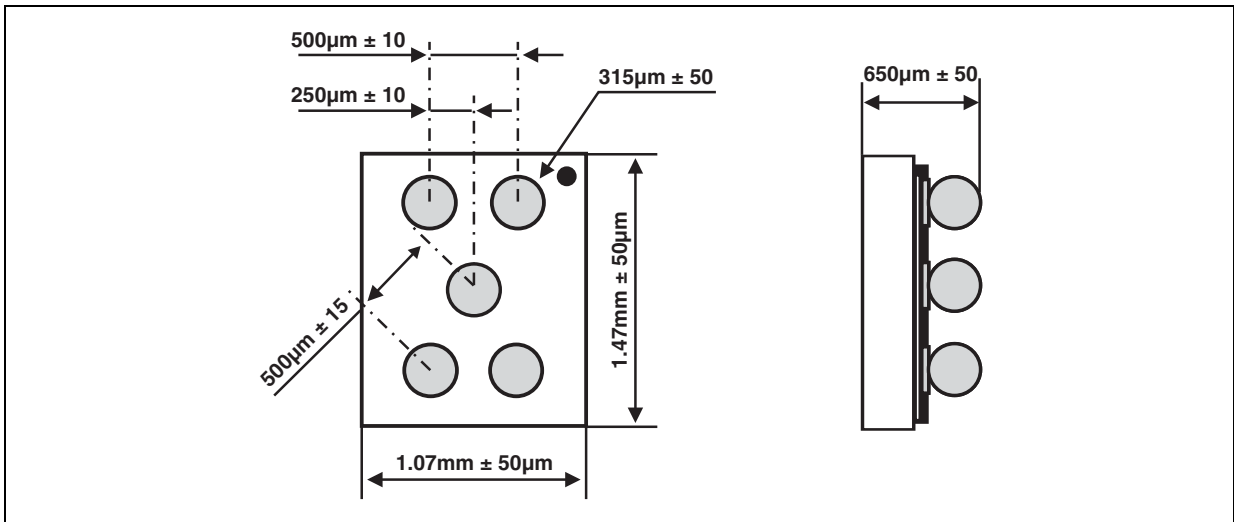

FOOT PRINT RECOMMENDATIONS

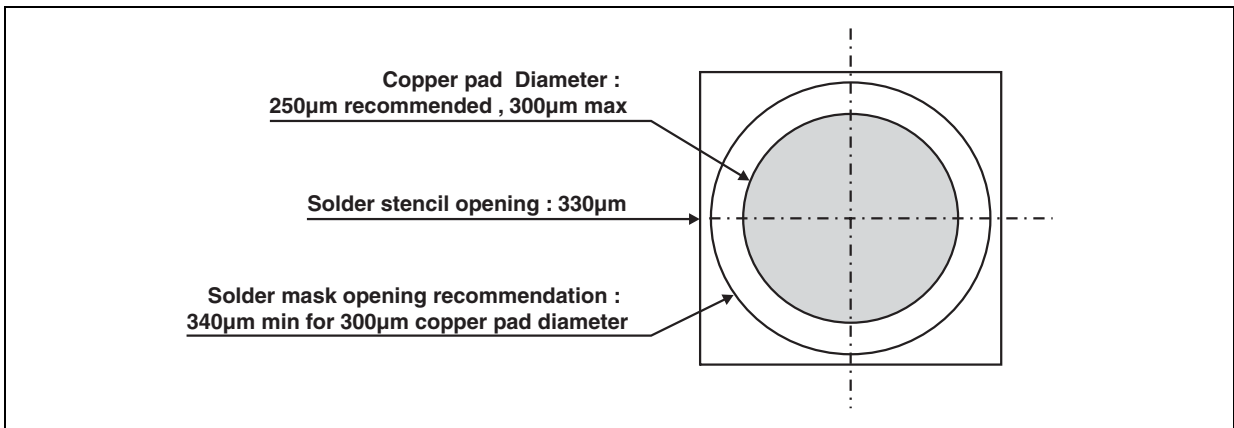

MARKING

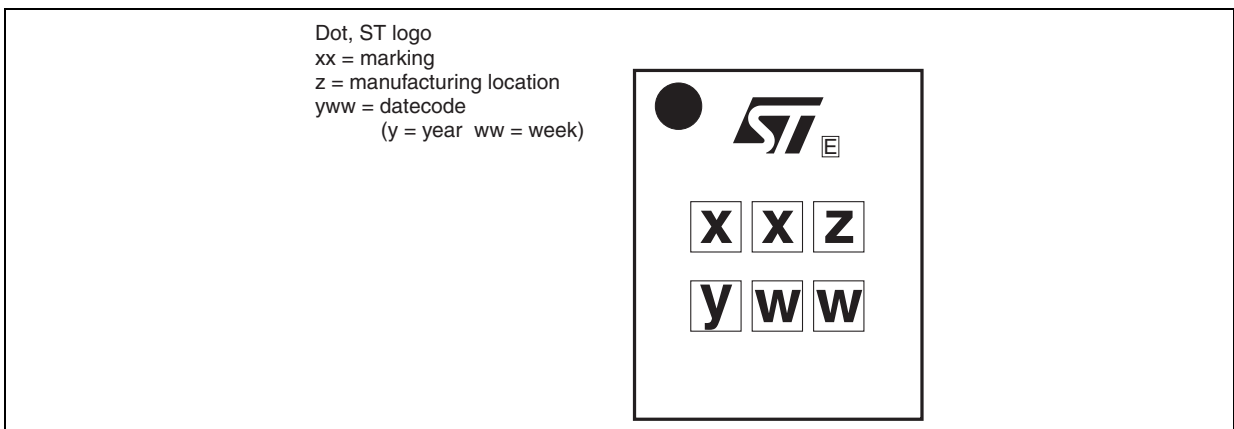

PACKING

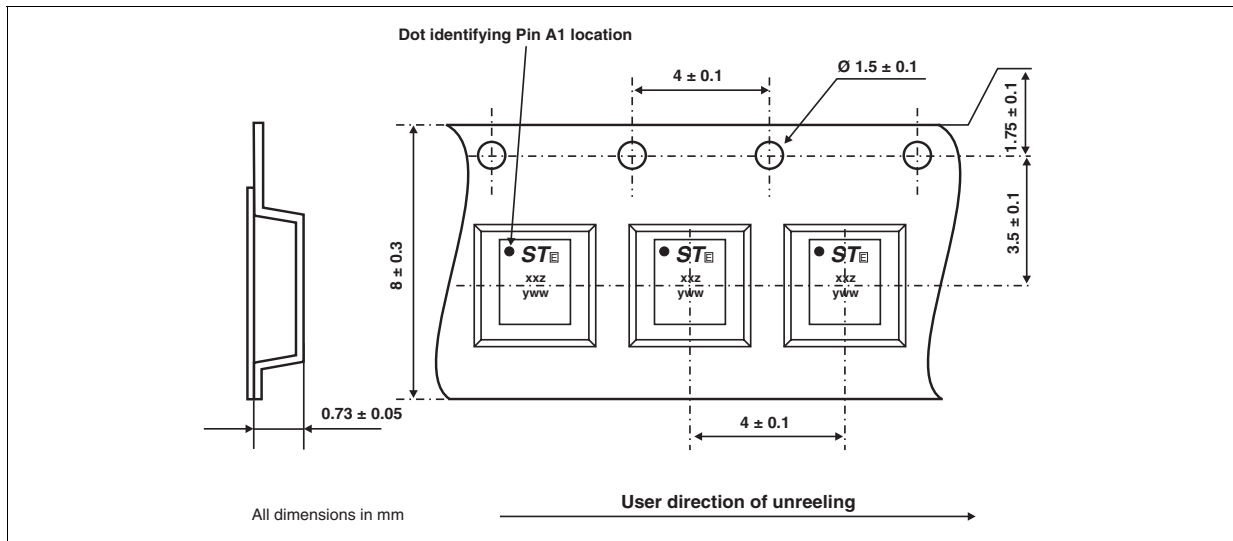

In order to meet environmental requirements, ST offers these devices in ECOPACK® packages. These packages have a Lead-free second level interconnect. The category of second level interconnect is marked on the inner box label, in compliance with JEDEC Standard JESD97. The maximum ratings related to soldering conditions are also marked on the inner box label. ECOPACK is an ST trademark. ECOPACK specifications are available at: www.st.com.

OTHER INFORMATION

Ordering code	Marking	Package	Weight	Base qty	Delivery mode
EMIF02-MIC03F2	FW	Flip-Chip	2.1 mg	5000	Tape & reel (7")

Note: More packing informations are available in the application notes
 AN1235: "Flip-Chip: Package description and recommendations for use"
 AN1751: "EMI Filters: Recommendations and measurements"

REVISION HISTORY

Date	Revision	Changes
14-Oct-2005	1	Initial release.

Information furnished is believed to be accurate and reliable. However, STMicroelectronics assumes no responsibility for the consequences of use of such information nor for any infringement of patents or other rights of third parties which may result from its use. No license is granted by implication or otherwise under any patent or patent rights of STMicroelectronics. Specifications mentioned in this publication are subject to change without notice. This publication supersedes and replaces all information previously supplied. STMicroelectronics products are not authorized for use as critical components in life support devices or systems without express written approval of STMicroelectronics.

The ST logo is a registered trademark of STMicroelectronics.
 All other names are the property of their respective owners

© 2005 STMicroelectronics - All rights reserved

STMicroelectronics GROUP OF COMPANIES

Australia - Belgium - Brazil - Canada - China - Czech Republic - Finland - France - Germany - Hong Kong - India - Israel - Italy - Japan - Malaysia - Malta - Morocco - Singapore - Spain - Sweden - Switzerland - United Kingdom - United States
www.st.com