

DS90CR287/DS90CR288A +3.3V Rising Edge Data Strobe LVDS 28-Bit Channel Link - 85MHz

Check for Samples: [DS90CR287](#), [DS90CR288A](#)

FEATURES

- 20 to 85 MHz Shift Clock Support
- 50% Duty Cycle on Receiver Output Clock
- 2.5 / 0 ns Set & Hold Times on TxINPUTS
- Low Power Consumption
- $\pm 1V$ Common-Mode Range (around +1.2V)
- Narrow Bus Reduces Cable Size and Cost
- Up to 2.38 Gbps Throughput
- Up to 297.5 Mbytes/sec Bandwidth
- 345 mV (typ) Swing LVDS Devices for Low EMI
- PLL Requires no External Components
- Rising Edge Data Strobe
- Compatible with TIA/EIA-644 LVDS Standard
- Low Profile 56-Lead TSSOP Package

DESCRIPTION

The DS90CR287 transmitter converts 28 bits of LVCMOS/LVTTL data into four LVDS (Low Voltage Differential Signaling) data streams. A phase-locked transmit clock is transmitted in parallel with the data streams over a fifth LVDS link. Every cycle of the transmit clock 28 bits of input data are sampled and transmitted.

The DS90CR288A receiver converts the four LVDS data streams back into 28 bits of LVCMOS/LVTTL data. At a transmit clock frequency of 85 MHz, 28 bits of TTL data are transmitted at a rate of 595 Mbps per LVDS data channel. Using a 85 MHz clock, the data throughput is 2.38 Gbit/s (297.5 Mbytes/sec).

This chipset is an ideal means to solve EMI and cable size problems associated with wide, high-speed TTL interfaces.

Block Diagram

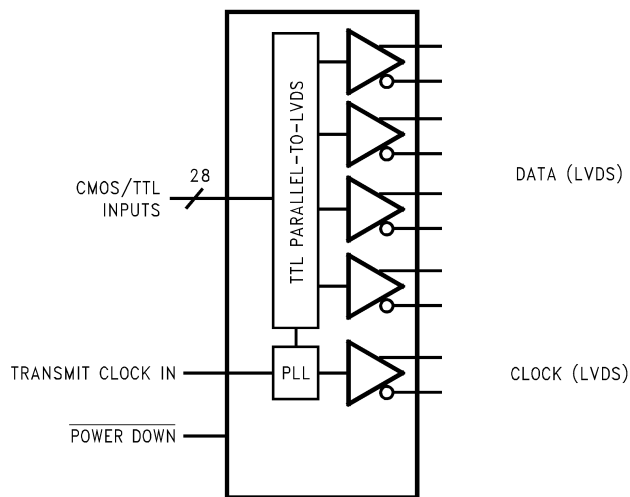

Figure 1. DS90CR287
See Package Number DGG-56 (TSSOP)

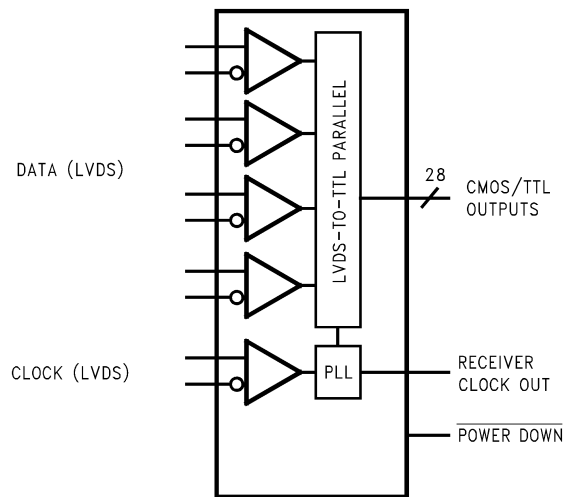

Figure 2. DS90CR288A
See Package Number DGG-56 (TSSOP)



Please be aware that an important notice concerning availability, standard warranty, and use in critical applications of Texas Instruments semiconductor products and disclaimers thereto appears at the end of this data sheet.

Pin Diagram for TSSOP Packages

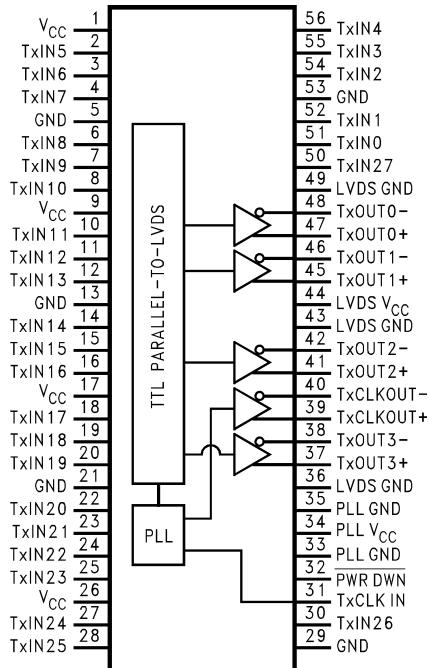

Figure 3. DS90CR287

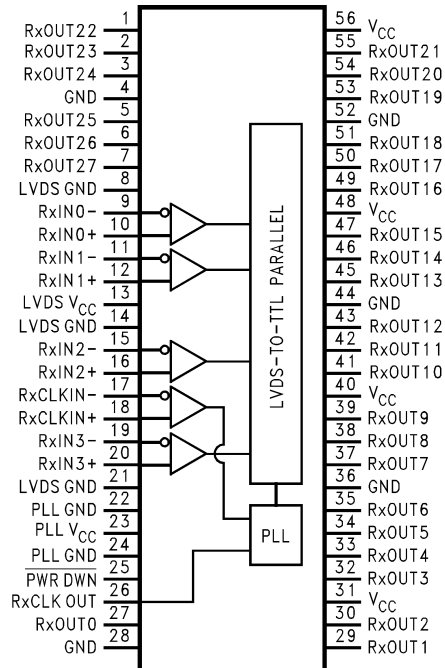

Figure 4. DS90CR288A

Typical Application

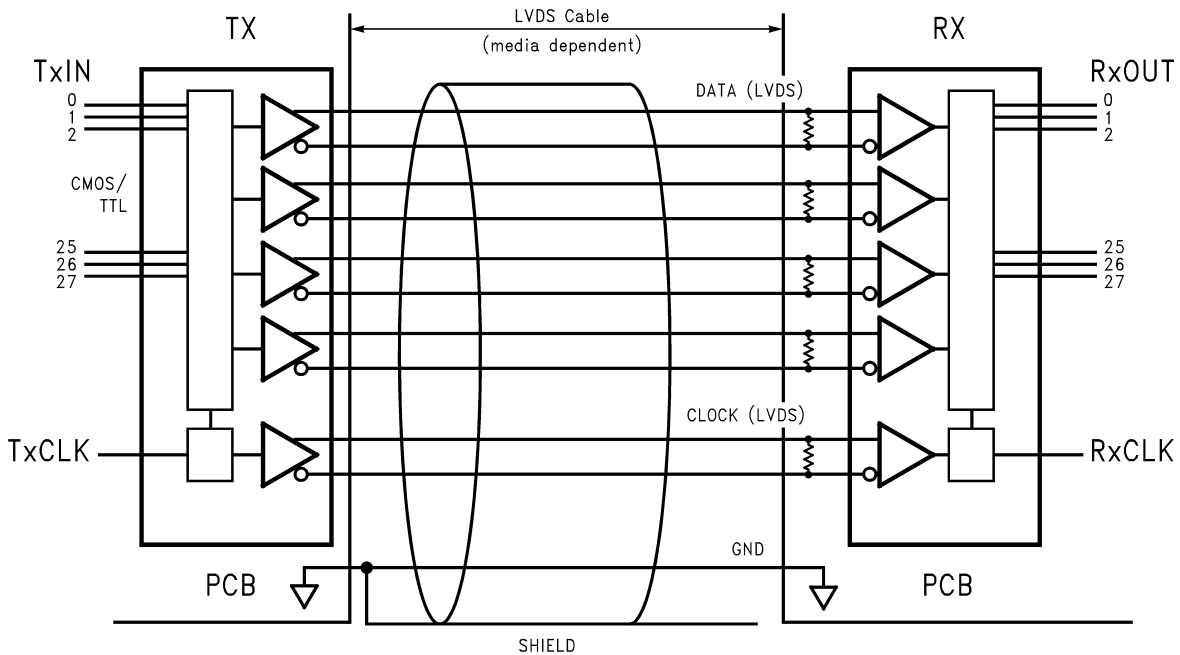

Figure 5. DS90CR288A



These devices have limited built-in ESD protection. The leads should be shorted together or the device placed in conductive foam during storage or handling to prevent electrostatic damage to the MOS gates.

Absolute Maximum Ratings⁽¹⁾⁽²⁾

Supply Voltage (V_{CC})				-0.3V to +4V
CMOS/TTL Input Voltage				-0.5V to ($V_{CC} + 0.3V$)
CMOS/TTL Output Voltage				-0.3V to ($V_{CC} + 0.3V$)
LVDS Receiver Input Voltage				-0.3V to ($V_{CC} + 0.3V$)
LVDS Driver Output Voltage				-0.3V to ($V_{CC} + 0.3V$)
LVDS Output Short Circuit Duration				Continuous
Junction Temperature				+150°C
Storage Temperature				-65°C to +150°C
Lead Temperature (Soldering, 4 sec.)				+260°C
Solder Reflow Temperature				
Maximum Package Power Dissipation @ +25°C	TSSOP Package	DS90CR287	1.63 W	
		DS90CR288A	1.61 W	
Package Derating	DS90CR287		12.5 mW/°C above +25°C	
	DS90CR288A		12.4 mW/°C above +25°C	
ESD Rating	(HBM, 1.5kΩ, 100pF)		> 7kV	
	(EIAJ, 0Ω, 200pF)		> 700V	
	Latch Up Tolerance @ +25°C		> ±300mA	

- (1) "Absolute Maximum Ratings" are those values beyond which the safety of the device cannot be guaranteed. They are not meant to imply that the device should be operated at these limits. "Electrical Characteristics" specify conditions for device operation.
- (2) If Military/Aerospace specified devices are required, please contact the Texas Instruments Sales Office/ Distributors for availability and specifications.

Recommended Operating Conditions

	Min	Nom	Max	Units
Supply Voltage (V_{CC})	3.0	3.3	3.6	V
Operating Free Air Temperature (T_A)	-10	+25	+70	°C
Receiver Input Range	0		2.4	V
Supply Noise Voltage (V_{CC})			100	mV _{PP}

Electrical Characteristics⁽¹⁾

Over recommended operating supply and temperature ranges unless otherwise specified

Symbol	Parameter	Conditions	Min	Typ ⁽²⁾	Max	Units	
LVCMOS/LVTTL DC SPECIFICATIONS							
V _{IH}	High Level Input Voltage		2.0		V _{CC}	V	
V _{IL}	Low Level Input Voltage		GND		0.8	V	
V _{OH}	High Level Output Voltage	I _{OH} = -0.4 mA	2.7	3.3		V	
V _{OL}	Low Level Output Voltage	I _{OL} = 2 mA		0.06	0.3	V	
V _{CL}	Input Clamp Voltage	I _{CL} = -18 mA		-0.79	-1.5	V	
I _{IN}	Input Current	V _{IN} = 0.4V, 2.5V or V _{CC}		+1.8	+15	μA	
		V _{IN} = GND	-10	0		μA	
I _{OS}	Output Short Circuit Current	V _{OUT} = 0V		-60	-120	mA	
LVDS DRIVER DC SPECIFICATIONS							
V _{OD}	Differential Output Voltage	R _L = 100Ω	250	290	450	mV	
ΔV _{OD}	Change in V _{OD} between Complimentary Output States				35	mV	
V _{OS}	Offset Voltage ⁽³⁾		1.125	1.25	1.375	V	
ΔV _{OS}	Change in V _{OS} between Complimentary Output States				35	mV	
I _{OS}	Output Short Circuit Current	V _{OUT} = 0V, R _L = 100Ω		-3.5	-5	mA	
I _{OZ}	Output TRI-STATE Current	PWR DWN = 0V, V _{OUT} = 0V or V _{CC}		±1	±10	μA	
LVDS RECEIVER DC SPECIFICATIONS							
V _{TH}	Differential Input High Threshold	V _{CM} = +1.2V			+100	mV	
V _{TL}	Differential Input Low Threshold		-100			mV	
I _{IN}	Input Current	V _{IN} = +2.4V, V _{CC} = 3.6V			±10	μA	
		V _{IN} = 0V, V _{CC} = 3.6V			±10	μA	
TRANSMITTER SUPPLY CURRENT							
I _{CCTW}	Transmitter Supply Current Worst Case (with Loads) ⁽⁴⁾	R _L = 100Ω, C _L = 5 pF, Worst Case Pattern Figure 6, Figure 7	f = 33 MHz		31	45	mA
			f = 40 MHz		32	50	mA
			f = 66 MHz		37	55	mA
			f = 85 MHz		42	60	mA
I _{CC TZ}	Transmitter Supply Current Power Down ⁽⁴⁾	PWR DWN = Low Driver Outputs in TRI-STATE under Powerdown Mode			10	55	μA
RECEIVER SUPPLY CURRENT							
I _{CCRW}	Receiver Supply Current Worst Case	C _L = 8 pF, Worst Case Pattern Figure 6, Figure 8	f = 33 MHz		49	70	mA
			f = 40 MHz		53	75	mA
			f = 66 MHz		81	114	mA
			f = 85 MHz		96	135	mA
I _{CCRZ}	Receiver Supply Current Power Down	PWR DWN = Low Receiver Outputs Stay Low during Powerdown Mode			140	400	μA

(1) "Absolute Maximum Ratings" are those values beyond which the safety of the device cannot be guaranteed. They are not meant to imply that the device should be operated at these limits. "Electrical Characteristics" specify conditions for device operation.

(2) Typical values are given for V_{CC} = 3.3V and T_A = +25°C.

(3) V_{OS} previously referred as V_{CM}.

(4) Current into device pins is defined as positive. Current out of device pins is defined as negative. Voltages are referenced to ground unless otherwise specified (except V_{OD} and ΔV_{OD}).

Transmitter Switching Characteristics

Over recommended operating supply and temperature ranges unless otherwise specified

Symbol	Parameter	Min	Typ ⁽¹⁾	Max	Units		
LLHT	LVDS Low-to-High Transition Time Figure 7		0.75	1.5	ns		
LHLT	LVDS High-to-Low Transition Time Figure 7		0.75	1.5	ns		
TCIT	TxCLK IN Transition Time Figure 9	1.0		6.0	ns		
TPPos0	Transmitter Output Pulse Position for Bit0 Figure 19	f = 85 MHz		-0.20	0	0.20	ns
TPPos1	Transmitter Output Pulse Position for Bit1		1.48	1.68	1.88	ns	
TPPos2	Transmitter Output Pulse Position for Bit2		3.16	3.36	3.56	ns	
TPPos3	Transmitter Output Pulse Position for Bit3		4.84	5.04	5.24	ns	
TPPos4	Transmitter Output Pulse Position for Bit4		6.52	6.72	6.92	ns	
TPPos5	Transmitter Output Pulse Position for Bit5		8.20	8.40	8.60	ns	
TPPos6	Transmitter Output Pulse Position for Bit6		9.88	10.08	10.28	ns	
TCIP	TxCLK IN Period Figure 10	11.76	T	50	ns		
TCIH	TxCLK IN High Time Figure 10	0.35T	0.5T	0.65T	ns		
TCIL	TxCLK IN Low Time Figure 10	0.35T	0.5T	0.65T	ns		
TSTC	TxIN Setup to TxCLK IN Figure 10	f = 85 MHz		2.5		ns	
THTC	TxIN Hold to TxCLK IN Figure 10		0		ns		
TCCD	TxCLK IN to TxCLK OUT Delay Figure 12	T _A = 25°C, V _{CC} = 3.3V		3.8		6.3	ns
TPLLS	Transmitter Phase Lock Loop Set Figure 14			10	ms		
TPDD	Transmitter Powerdown Delay Figure 17			100	ns		
TJIT	TxCLK IN Cycle-to-Cycle Jitter (Input clock requirement)			2	ns		

(1) Typical values are given for V_{CC} = 3.3V and T_A = +25°C.

Receiver Switching Characteristics

Over recommended operating supply and temperature ranges unless otherwise specified

Symbol	Parameter	Min	Typ ⁽¹⁾	Max	Units		
CLHT	CMOS/TTL Low-to-High Transition Time Figure 8		2	3.5	ns		
CHLT	CMOS/TTL High-to-Low Transition Time Figure 8		1.8	3.5	ns		
RSPos0	Receiver Input Strobe Position for Bit 0 Figure 20	f = 85 MHz		0.49	0.84	1.19	ns
RSPos1	Receiver Input Strobe Position for Bit 1	2.17	2.52	2.87	ns		
RSPos2	Receiver Input Strobe Position for Bit 2	3.85	4.20	4.55	ns		
RSPos3	Receiver Input Strobe Position for Bit 3	5.53	5.88	6.23	ns		
RSPos4	Receiver Input Strobe Position for Bit 4	7.21	7.56	7.91	ns		
RSPos5	Receiver Input Strobe Position for Bit 5	8.89	9.24	9.59	ns		
RSPos6	Receiver Input Strobe Position for Bit 6	10.57	10.92	11.27	ns		
RSKM	RxIN Skew Margin ⁽²⁾ Figure 21	f = 85 MHz		290		ps	
RCOP	RxCLK OUT Period Figure 11	11.76	T	50	ns		
RCOH	RxCLK OUT High Time Figure 11	f = 85 MHz		4	5	6.5	ns
RCOL	RxCLK OUT Low Time Figure 11	3.5	5	6	ns		
RSRC	RxOUT Setup to RxCLK OUT Figure 11	3.5			ns		
RHRC	RxOUT Hold to RxCLK OUT Figure 11	3.5			ns		
RCCD	RxCLK IN to RxCLK OUT Delay @ 25°C, V _{CC} = 3.3V ⁽³⁾ Figure 13	5.5	7	9.5	ns		
RPLLS	Receiver Phase Lock Loop Set Figure 15			10	ms		
RPDD	Receiver Powerdown Delay Figure 18			1	μs		

(1) Typical values are given for V_{CC} = 3.3V and T_A = +25°C.

(2) Receiver Skew Margin is defined as the valid data sampling region at the receiver inputs. This margin takes into account the transmitter pulse positions (min and max) and the receiver input setup and hold time (internal data sampling window-RSPOS). This margin allows LVDS interconnect skew, inter-symbol interference (both dependent on type/length of cable), and source clock (less than 150 ps).

(3) Total latency for the channel link chipset is a function of clock period and gate delays through the transmitter (TCCD) and receiver (RCCD). The total latency for the 217/287 transmitter and 218/288A receiver is: (T + TCCD) + (2*T + RCCD), where T = Clock period.

AC Timing Diagrams

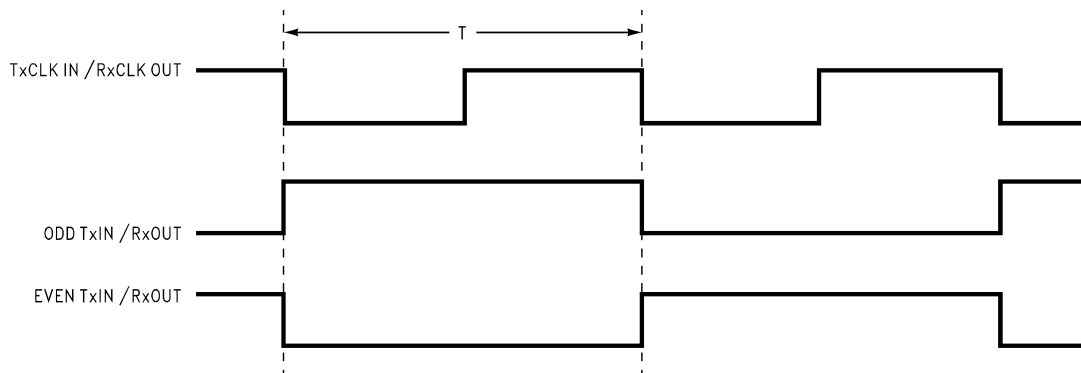

Figure 6. "Worst Case" Test Pattern

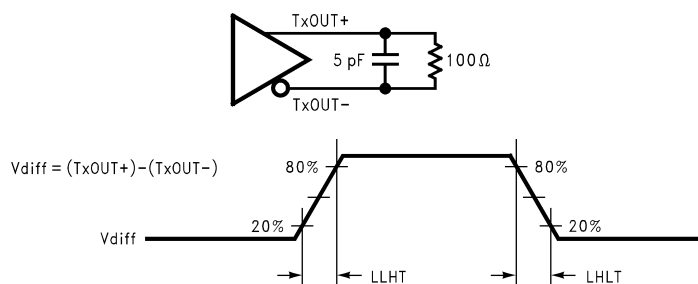

Figure 7. DS90CR287 (Transmitter) LVDS Output Load and Transition Times

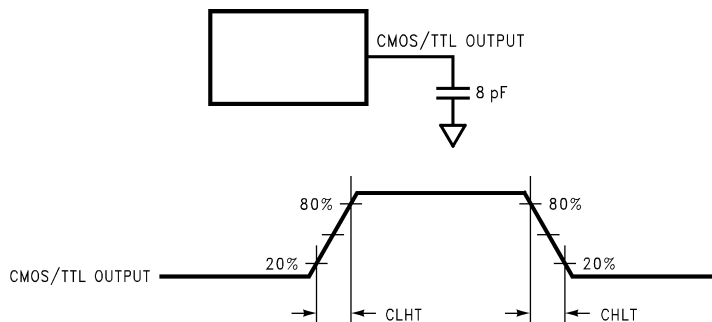

Figure 8. DS90CR288A (Receiver) CMOS/TTL Output Load and Transition Times

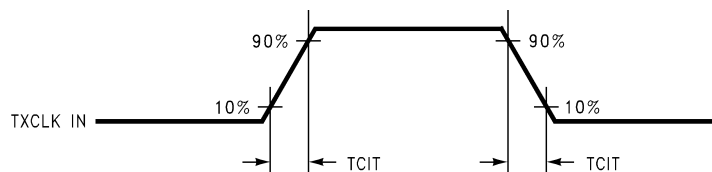

Figure 9. DS90CR287 (Transmitter) Input Clock Transition Time

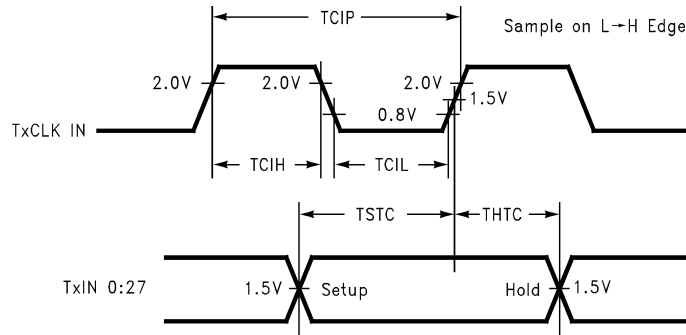

Figure 10. DS90CR287 (Transmitter) Setup/Hold and High/Low Times

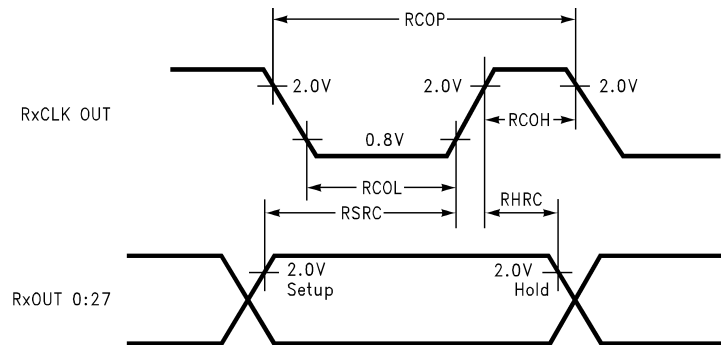

Figure 11. DS90CR288A (Receiver) Setup/Hold and High/Low Times

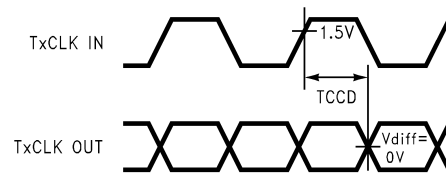

Figure 12. DS90CR287 (Transmitter) Clock In to Clock Out Delay

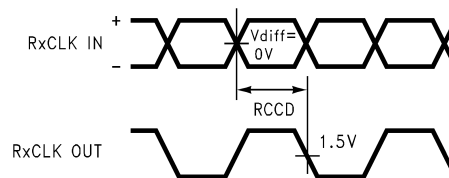

Figure 13. DS90CR288A (Receiver) Clock In to Clock Out Delay

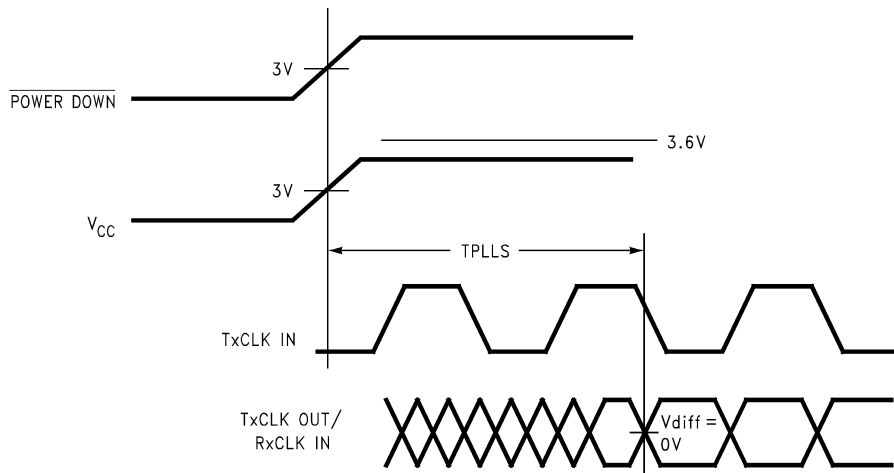

Figure 14. DS90CR287 (Transmitter) Phase Lock Loop Set Time

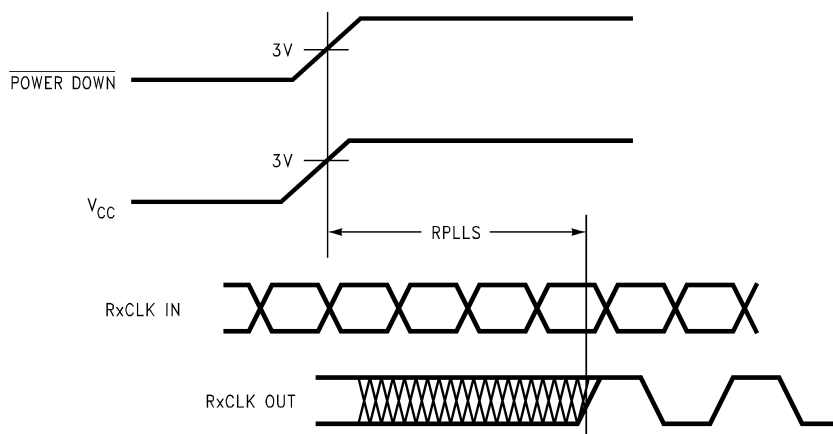

Figure 15. DS90CR288A (Receiver) Phase Lock Loop Set Time

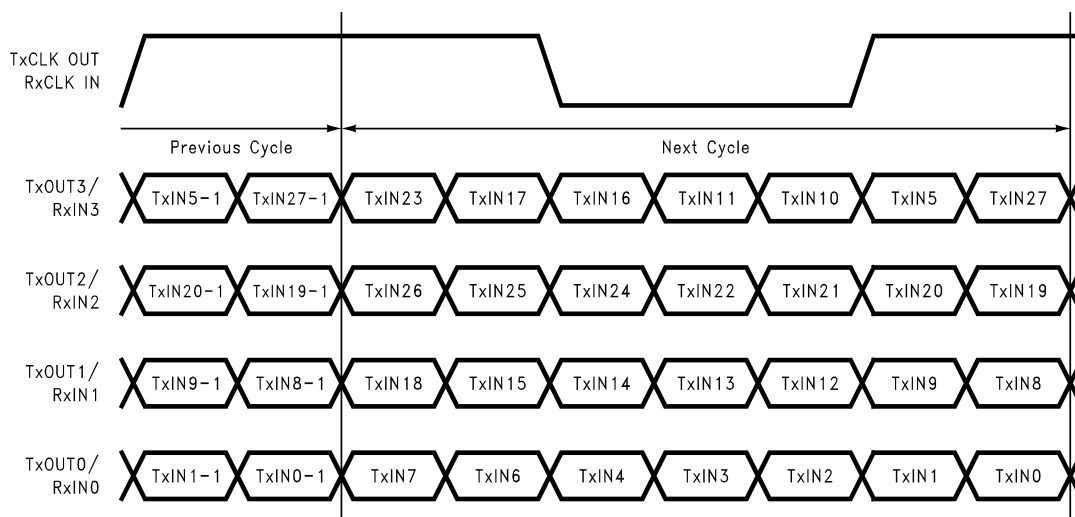

Figure 16. 28 Parallel TTL Data Inputs Mapped to LVDS Outputs

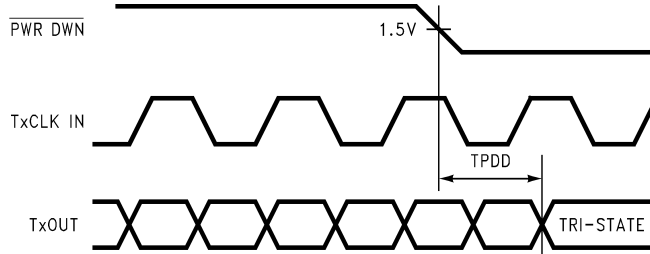

Figure 17. Transmitter Powerdown Delay

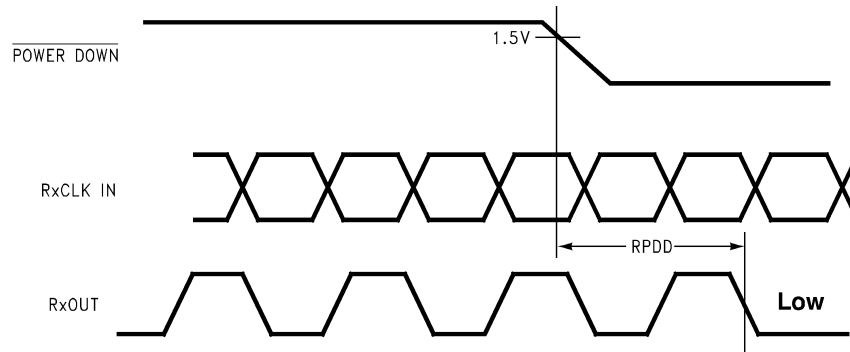

Figure 18. Receiver Powerdown Delay

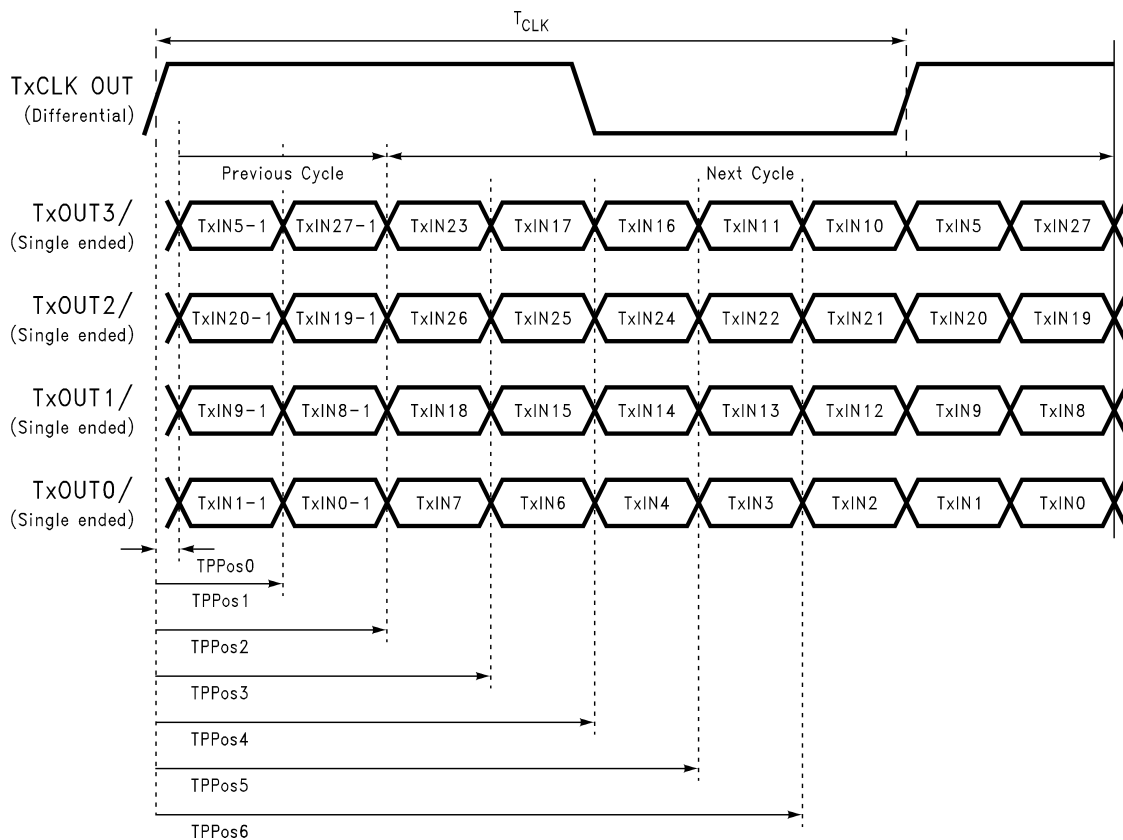

Figure 19. Transmitter LVDS Output Pulse Position Measurement

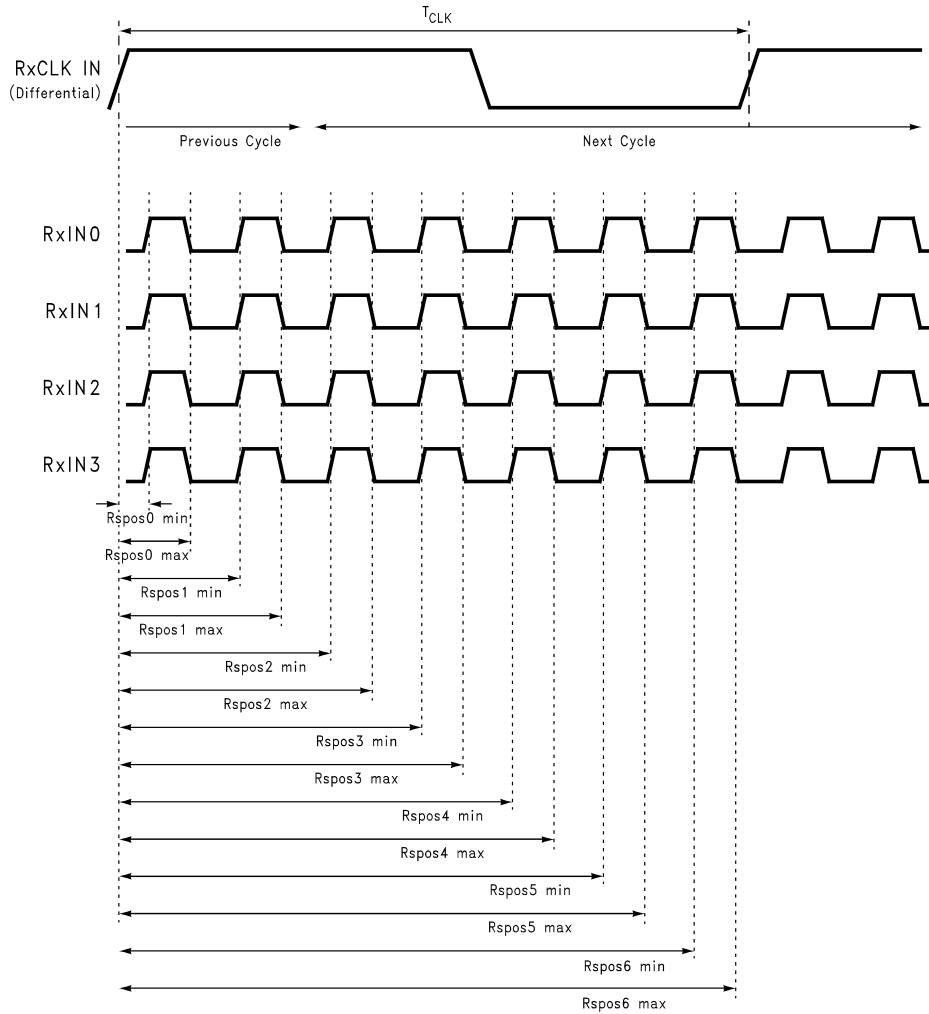
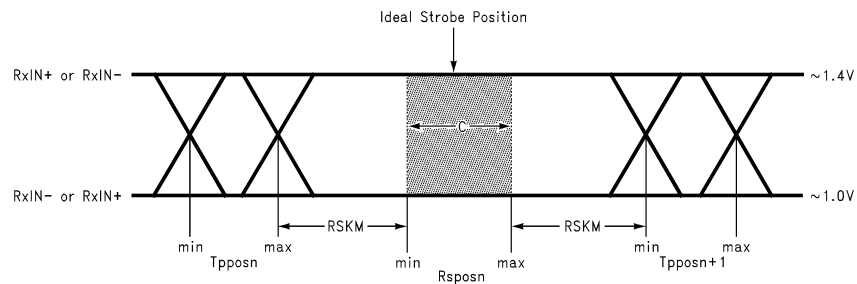

Figure 20. Receiver LVDS Input Strobe Position



C—Setup and Hold Time (Internal data sampling window) defined by Rspos (receiver input strobe position) min and max

Tppos—Transmitter output pulse position (min and max)

$RSKM \geq \text{Cable Skew (type, length)} + \text{Source Clock Jitter (cycle to cycle)}^{(1)} + \text{ISI (Inter-symbol interference)}^{(2)}$

Cable Skew—typically 10 ps–40 ps per foot, media dependent

- (1) Cycle-to-cycle jitter is less than 150ps at 85MHz.
- (2) ISI is dependent on interconnect length; may be zero.

Figure 21. Receiver LVDS Input Skew Margin

DS90CR287 DGG (TSSOP) Package PIN DESCRIPTION — Channel Link Transmitter

Pin Name	I/O	No.	Description
TxIN	I	28	TTL level input.
TxOUT+	O	4	Positive LVDS differential data output.
TxOUT-	O	4	Negative LVDS differential data output.
TxCLK IN	I	1	TTL level clock input. The rising edge acts as data strobe. Pin name TxCLK IN. See APPLICATIONS INFORMATION section.
TxCLK OUT+	O	1	Positive LVDS differential clock output.
TxCLK OUT-	O	1	Negative LVDS differential clock output.
$\overline{\text{PWR DOWN}}$	I	1	TTL level input. Assertion (low input) TRI-STATES the outputs, ensuring low current at power down. See APPLICATIONS INFORMATION section.
V _{CC}	I	4	Power supply pins for TTL inputs.
GND	I	5	Ground pins for TTL inputs.
PLL V _{CC}	I	1	Power supply pin for PLL.
PLL GND	I	2	Ground pins for PLL.
LVDS V _{CC}	I	1	Power supply pin for LVDS outputs.
LVDS GND	I	3	Ground pins for LVDS outputs.

DS90CR288A DGG (TSSOP) Package PIN DESCRIPTION — Channel Link Receiver

Pin Name	I/O	No.	Description
RxIN+	I	4	Positive LVDS differential data inputs.
RxIN-	I	4	Negative LVDS differential data inputs.
RxOUT	O	28	TTL level data outputs.
RxCLK IN+	I	1	Positive LVDS differential clock input.
RxCLK IN-	I	1	Negative LVDS differential clock input.
RxCLK OUT	O	1	TTL level clock output. The rising edge acts as data strobe. Pin name RxCLK OUT.
$\overline{\text{PWR DOWN}}$	I	1	TTL level input. When asserted (low input) the receiver outputs are low.
V _{CC}	I	4	Power supply pins for TTL outputs.
GND	I	5	Ground pins for TTL outputs.
PLL V _{CC}	I	1	Power supply for PLL.
PLL GND	I	2	Ground pin for PLL.
LVDS V _{CC}	I	1	Power supply pin for LVDS inputs.
LVDS GND	I	3	Ground pins for LVDS inputs.

APPLICATIONS INFORMATION

The TSSOP version of the DS90CR287 and DS90CR288A are backward compatible with the existing 5V Channel Link transmitter/receiver pair (DS90CR283, DS90CR284). To upgrade from a 5V to a 3.3V system the following must be addressed:

1. Change 5V power supply to 3.3V. Provide this supply to the V_{CC} , LVDS V_{CC} and PLL V_{CC} .
2. Transmitter input and control inputs except 3.3V TTL/CMOS levels. They are not 5V tolerant.
3. The receiver powerdown feature when enabled will lock receiver output to a logic low.

The Channel Link devices are intended to be used in a wide variety of data transmission applications. Depending upon the application the interconnecting media may vary. For example, for lower data rate (clock rate) and shorter cable lengths (< 2m), the media electrical performance is less critical. For higher speed/long distance applications the media's performance becomes more critical. Certain cable constructions provide tighter skew (matched electrical length between the conductors and pairs). Additional applications information can be found in the following Interface Application Notes:

AN = ####	Topic
AN-1041 (SNLA218)	Introduction to Channel Link
AN-1108(SNLA008)	Channel Link PCB and Interconnect Design-In Guidelines
AN-806 (SNLA026)	Transmission Line Theory
AN-905 (SNLA035)	Transmission Line Calculations and Differential Impedance
AN-916 (SNLA219)	Cable Information

CABLES: A cable interface between the transmitter and receiver needs to support the differential LVDS pairs. The 21-bit CHANNEL LINK chipset (DS90CR217/218A) requires four pairs of signal wires and the 28-bit CHANNEL LINK chipset (DS90CR287/288A) requires five pairs of signal wires. The ideal cable/connector interface would have a constant 100Ω differential impedance throughout the path. It is also recommended that cable skew remain below 140ps (@ 85 MHz clock rate) to maintain a sufficient data sampling window at the receiver.

In addition to the four or five cable pairs that carry data and clock, it is recommended to provide at least one additional conductor (or pair) which connects ground between the transmitter and receiver. This low impedance ground provides a common-mode return path for the two devices. Some of the more commonly used cable types for point-to-point applications include flat ribbon, flex, twisted pair and Twin-Coax. All are available in a variety of configurations and options. Flat ribbon cable, flex and twisted pair generally perform well in short point-to-point applications while Twin-Coax is good for short and long applications. When using ribbon cable, it is recommended to place a ground line between each differential pair to act as a barrier to noise coupling between adjacent pairs. For Twin-Coax cable applications, it is recommended to utilize a shield on each cable pair. All extended point-to-point applications should also employ an overall shield surrounding all cable pairs regardless of the cable type. This overall shield results in improved transmission parameters such as faster attainable speeds, longer distances between transmitter and receiver and reduced problems associated with EMS or EMI.

The high-speed transport of LVDS signals has been demonstrated on several types of cables with excellent results. However, the best overall performance has been seen when using Twin-Coax cable. Twin-Coax has very low cable skew and EMI due to its construction and double shielding. All of the design considerations discussed here and listed in the supplemental application notes provide the subsystem communications designer with many useful guidelines. It is recommended that the designer assess the tradeoffs of each application thoroughly to arrive at a reliable and economical cable solution.

RECEIVER FAILSAFE FEATURE: These receivers have input failsafe bias circuitry to guarantee a stable receiver output for floating or terminated receiver inputs. Under these conditions receiver inputs will be in a HIGH state. If a clock signal is present, data outputs will all be HIGH; if the clock input is also floating/terminated, data outputs will remain in the last valid state. A floating/terminated clock input will result in a HIGH clock output.

BOARD LAYOUT: To obtain the maximum benefit from the noise and EMI reductions of LVDS, attention should be paid to the layout of differential lines. Lines of a differential pair should always be adjacent to eliminate noise interference from other signals and take full advantage of the noise canceling of the differential signals. The board designer should also try to maintain equal length on signal traces for a given differential pair. As with any high-speed design, the impedance discontinuities should be limited (reduce the numbers of vias and no 90 degree angles on traces). Any discontinuities which do occur on one signal line should be mirrored in the other

line of the differential pair. Care should be taken to ensure that the differential trace impedance match the differential impedance of the selected physical media (this impedance should also match the value of the termination resistor that is connected across the differential pair at the receiver's input). Finally, the location of the CHANNEL LINK TxOUT/RxIN pins should be as close as possible to the board edge so as to eliminate excessive pcb runs. All of these considerations will limit reflections and crosstalk which adversely effect high frequency performance and EMI.

INPUTS: The TxIN and control pin inputs are compatible with LVTTTL and LVCMOS levels. This pins are not 5V tolerant.

UNUSED INPUTS: All unused inputs at the TxIN inputs of the transmitter may be tied to ground or left no connect. All unused outputs at the RxOUT outputs of the receiver must then be left floating.

TERMINATION: Use of current mode drivers requires a terminating resistor across the receiver inputs. The CHANNEL LINK chipset will normally require a single 100Ω resistor between the true and complement lines on each differential pair of the receiver input. The actual value of the termination resistor should be selected to match the differential mode characteristic impedance (90Ω to 120Ω typical) of the cable. Figure 22 shows an example. No additional pull-up or pull-down resistors are necessary as with some other differential technologies such as PECL. Surface mount resistors are recommended to avoid the additional inductance that accompanies leaded resistors. These resistors should be placed as close as possible to the receiver input pins to reduce stubs and effectively terminate the differential lines.

DECOUPLING CAPACITORS: Bypassing capacitors are needed to reduce the impact of switching noise which could limit performance. For a conservative approach three parallel-connected decoupling capacitors (Multi-Layered Ceramic type in surface mount form factor) between each V_{CC} and the ground plane(s) are recommended. The three capacitor values are 0.1 μF, 0.01 μF and 0.001 μF. An example is shown in Figure 23. The designer should employ wide traces for power and ground and ensure each capacitor has its own via to the ground plane. If board space is limiting the number of bypass capacitors, the PLL V_{CC} should receive the most filtering/bypassing. Next would be the LVDS V_{CC} pins and finally the logic V_{CC} pins.

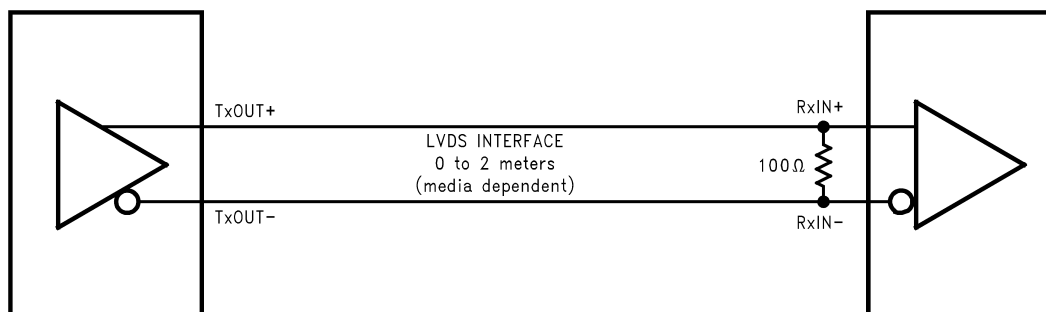

Figure 22. LVDS Serialized Link Termination

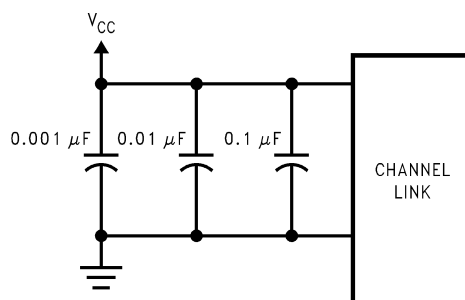

Figure 23. CHANNEL LINK Decoupling Configuration

CLOCK JITTER: The CHANNEL LINK devices employ a PLL to generate and recover the clock transmitted across the LVDS interface. The width of each bit in the serialized LVDS data stream is one-seventh the clock period. For example, a 85 MHz clock has a period of 11.76 ns which results in a data bit width of 1.68 ns. Differential skew (Δt within one differential pair), interconnect skew (Δt of one differential pair to another) and clock jitter will all reduce the available window for sampling the LVDS serial data streams. Care must be taken to ensure that the clock input to the transmitter be a clean low noise signal. Individual bypassing of each V_{CC} to ground will minimize the noise passed on to the PLL, thus creating a low jitter LVDS clock. These measures provide more margin for channel-to-channel skew and interconnect skew as a part of the overall jitter/skew budget.

INPUT CLOCK: The input clock should be present at all times when the part is enabled. If the clock is stopped, the PWR DOWN pin should be asserted to disable the PLL. Once the clock is active again, the part can then be enabled. Do not enable the part without a clock present.

COMMON-MODE vs. DIFFERENTIAL MODE NOISE MARGIN: The typical signal swing for LVDS is 300 mV centered at +1.2V. The CHANNEL LINK receiver supports a 100 mV threshold therefore providing approximately 200 mV of differential noise margin. Common-mode protection is of more importance to the system's operation due to the differential data transmission. LVDS supports an input voltage range of Ground to +2.4V. This allows for a $\pm 1.0V$ shifting of the center point due to ground potential differences and common-mode noise.

TRANSMITTER INPUT CLOCK: The transmitter input clock must always be present when the device is enabled ($\overline{\text{PWR DOWN}} = \text{HIGH}$). If the clock is stopped, the $\overline{\text{PWR DOWN}}$ pin must be used to disable the PLL. The $\overline{\text{PWR DOWN}}$ pin must be held low until after the input clock signal has been reapplied. This will ensure a proper device reset and PLL lock to occur.

POWER SEQUENCING AND POWERDOWN MODE: Outputs of the CHANNEL LINK transmitter remain in TRI-STATE until the power supply reaches 2V. Clock and data outputs will begin to toggle 10 ms after V_{CC} has reached 3V and the Powerdown pin is above 1.5V. Either device may be placed into a powerdown mode at any time by asserting the Powerdown pin (active low). Total power dissipation for each device will decrease to 5 μW (typical).

The transmitter input clock may be applied prior to powering up and enabling the transmitter. The transmitter input clock may also be applied after power up; however, the use of the PWR DOWN pin is required. Do not power up and enable ($\overline{\text{PWR DOWN}} = \text{HIGH}$) the transmitter without a valid clock signal applied to the TxCLK IN pin.

The CHANNEL LINK chipset is designed to protect itself from accidental loss of power to either the transmitter or receiver. If power to the transmit board is lost, the receiver clocks (input and output) stop. The data outputs (RxOUT) retain the states they were in when the clocks stopped. When the receiver board loses power, the receiver inputs are shorted to V_{CC} through an internal diode. Current is limited (5 mA per input) by the fixed current mode drivers, thus avoiding the potential for latchup when powering the device.

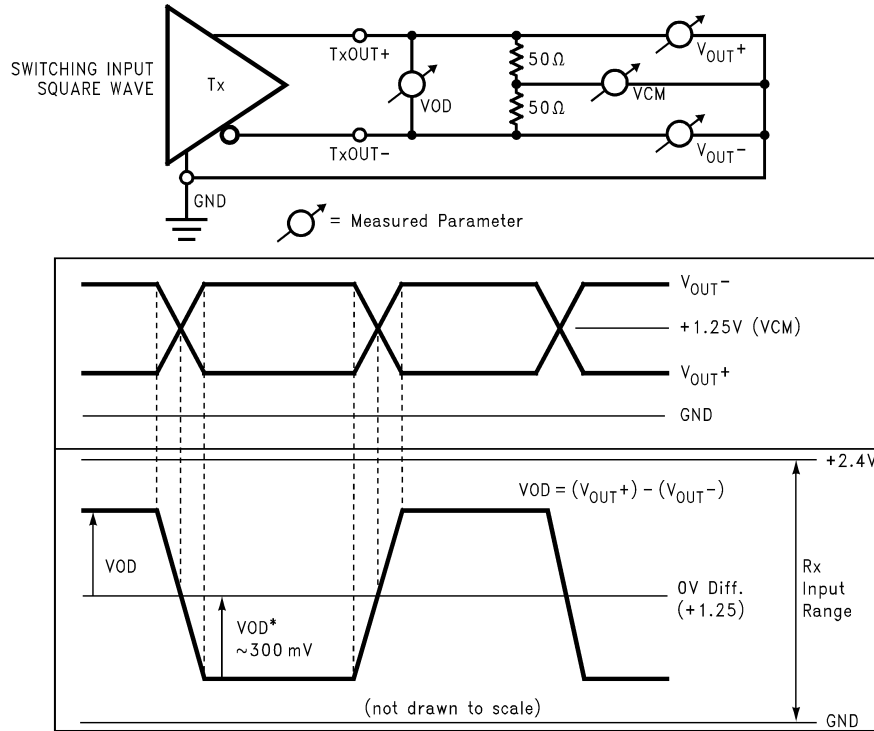

Figure 24. Single-Ended and Differential Waveforms

REVISION HISTORY

Changes from Revision F (March 2013) to Revision G	Page
<hr/> <ul style="list-style-type: none">• Changed layout of National Data Sheet to TI format	<hr/> 16

PACKAGING INFORMATION

Orderable Device	Status (1)	Package Type	Package Drawing	Pins	Package Qty	Eco Plan (2)	Lead/Ball Finish (6)	MSL Peak Temp (3)	Op Temp (°C)	Device Marking (4/5)	Samples
DS90CR287MTD	ACTIVE	TSSOP	DGG	56	34	TBD	Call TI	Call TI	-10 to 70	DS90CR287MTD >B	Samples
DS90CR287MTD/NOPB	ACTIVE	TSSOP	DGG	56	34	Green (RoHS & no Sb/Br)	CU SN	Level-2-260C-1 YEAR	-10 to 70	DS90CR287MTD >B	Samples
DS90CR287MTDX/NOPB	ACTIVE	TSSOP	DGG	56	1000	Green (RoHS & no Sb/Br)	CU SN	Level-2-260C-1 YEAR	-10 to 70	DS90CR287MTD >B	Samples
DS90CR287SLC/NOPB	NRND	NFBGA	NZC	64	360	Green (RoHS & no Sb/Br)	SNAGCU SNAGCU	Level-4-260C-72 HR		DS90CR287 SLC >B	
DS90CR288AMTD	ACTIVE	TSSOP	DGG	56	34	TBD	Call TI	Call TI	-10 to 70	DS90CR288AMTD >B	Samples
DS90CR288AMTD/NOPB	ACTIVE	TSSOP	DGG	56	34	Green (RoHS & no Sb/Br)	CU SN	Level-2-260C-1 YEAR	-10 to 70	DS90CR288AMTD >B	Samples
DS90CR288AMTDX	ACTIVE	TSSOP	DGG	56	1000	TBD	Call TI	Call TI	-10 to 70	DS90CR288AMTD >B	Samples
DS90CR288AMTDX/NOPB	ACTIVE	TSSOP	DGG	56	1000	Green (RoHS & no Sb/Br)	CU SN	Level-2-260C-1 YEAR	-10 to 70	DS90CR288AMTD >B	Samples

(1) The marketing status values are defined as follows:

ACTIVE: Product device recommended for new designs.

LIFEBUY: TI has announced that the device will be discontinued, and a lifetime-buy period is in effect.

NRND: Not recommended for new designs. Device is in production to support existing customers, but TI does not recommend using this part in a new design.

PREVIEW: Device has been announced but is not in production. Samples may or may not be available.

OBSOLETE: TI has discontinued the production of the device.

(2) Eco Plan - The planned eco-friendly classification: Pb-Free (RoHS), Pb-Free (RoHS Exempt), or Green (RoHS & no Sb/Br) - please check <http://www.ti.com/productcontent> for the latest availability information and additional product content details.

TBD: The Pb-Free/Green conversion plan has not been defined.

Pb-Free (RoHS): TI's terms "Lead-Free" or "Pb-Free" mean semiconductor products that are compatible with the current RoHS requirements for all 6 substances, including the requirement that lead not exceed 0.1% by weight in homogeneous materials. Where designed to be soldered at high temperatures, TI Pb-Free products are suitable for use in specified lead-free processes.

Pb-Free (RoHS Exempt): This component has a RoHS exemption for either 1) lead-based flip-chip solder bumps used between the die and package, or 2) lead-based die adhesive used between the die and leadframe. The component is otherwise considered Pb-Free (RoHS compatible) as defined above.

Green (RoHS & no Sb/Br): TI defines "Green" to mean Pb-Free (RoHS compatible), and free of Bromine (Br) and Antimony (Sb) based flame retardants (Br or Sb do not exceed 0.1% by weight in homogeneous material)

(3) MSL, Peak Temp. - The Moisture Sensitivity Level rating according to the JEDEC industry standard classifications, and peak solder temperature.

(4) There may be additional marking, which relates to the logo, the lot trace code information, or the environmental category on the device.

(5) Multiple Device Markings will be inside parentheses. Only one Device Marking contained in parentheses and separated by a "~" will appear on a device. If a line is indented then it is a continuation of the previous line and the two combined represent the entire Device Marking for that device.

(6) Lead/Ball Finish - Orderable Devices may have multiple material finish options. Finish options are separated by a vertical ruled line. Lead/Ball Finish values may wrap to two lines if the finish value exceeds the maximum column width.

Important Information and Disclaimer:The information provided on this page represents TI's knowledge and belief as of the date that it is provided. TI bases its knowledge and belief on information provided by third parties, and makes no representation or warranty as to the accuracy of such information. Efforts are underway to better integrate information from third parties. TI has taken and continues to take reasonable steps to provide representative and accurate information but may not have conducted destructive testing or chemical analysis on incoming materials and chemicals. TI and TI suppliers consider certain information to be proprietary, and thus CAS numbers and other limited information may not be available for release.

In no event shall TI's liability arising out of such information exceed the total purchase price of the TI part(s) at issue in this document sold by TI to Customer on an annual basis.

TAPE AND REEL INFORMATION



QUADRANT ASSIGNMENTS FOR PIN 1 ORIENTATION IN TAPE



*All dimensions are nominal

Device	Package Type	Package Drawing	Pins	SPQ	Reel Diameter (mm)	Reel Width W1 (mm)	A0 (mm)	B0 (mm)	K0 (mm)	P1 (mm)	W (mm)	Pin1 Quadrant
DS90CR287MTDX/NOPB	TSSOP	DGG	56	1000	330.0	24.4	8.6	14.5	1.8	12.0	24.0	Q1
DS90CR288AMTDX	TSSOP	DGG	56	1000	330.0	24.4	8.6	14.5	1.8	12.0	24.0	Q1
DS90CR288AMTDX/NOPB	TSSOP	DGG	56	1000	330.0	24.4	8.6	14.5	1.8	12.0	24.0	Q1

TAPE AND REEL BOX DIMENSIONS

*All dimensions are nominal

Device	Package Type	Package Drawing	Pins	SPQ	Length (mm)	Width (mm)	Height (mm)
DS90CR287MTDX/NOPB	TSSOP	DGG	56	1000	367.0	367.0	45.0
DS90CR288AMTDX	TSSOP	DGG	56	1000	367.0	367.0	45.0
DS90CR288AMTDX/NOPB	TSSOP	DGG	56	1000	367.0	367.0	45.0

NZC0064A

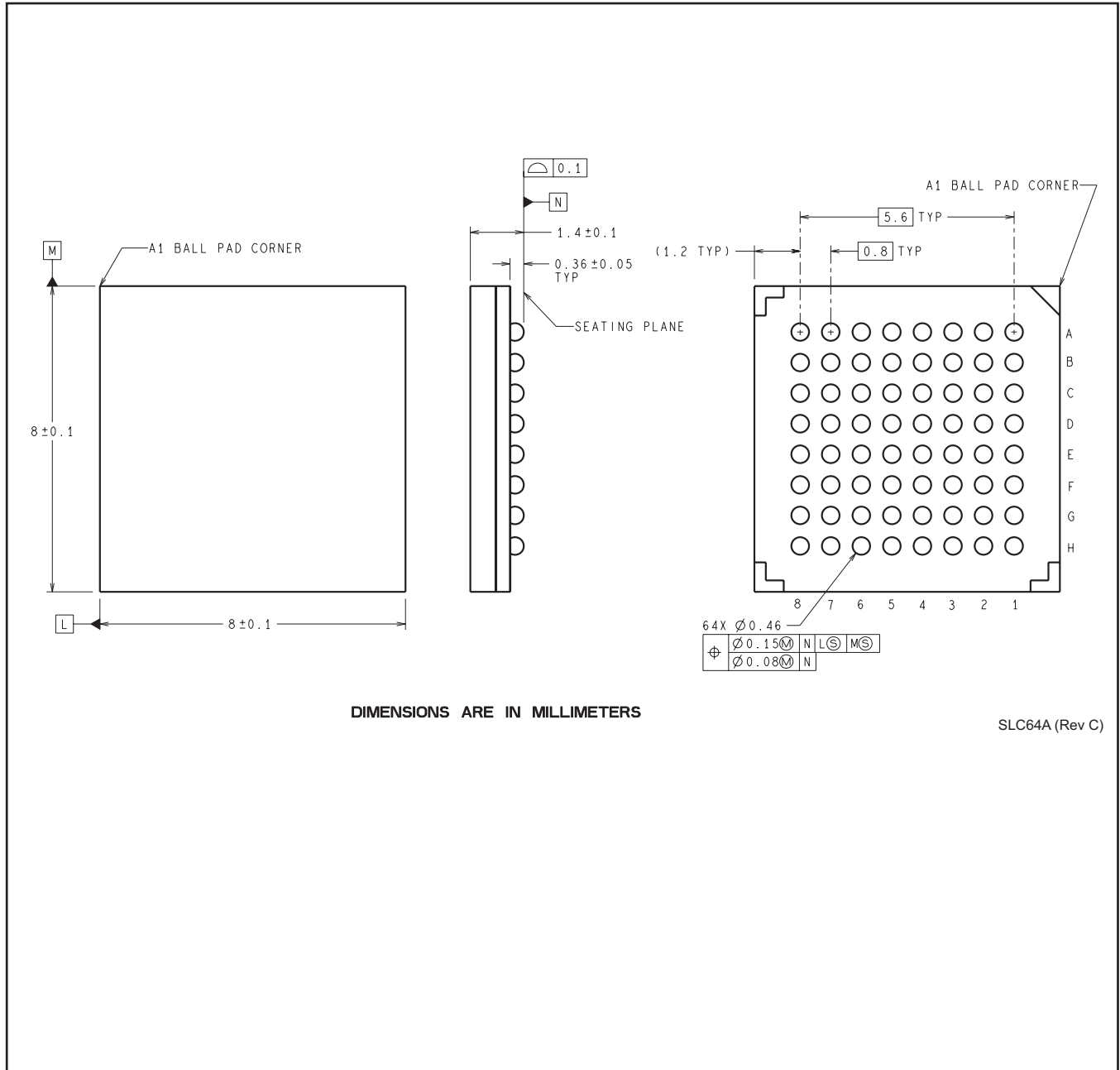

DIMENSIONS ARE IN MILLIMETERS

SLC64A (Rev C)

DGG (R-PDSO-G**)

PLASTIC SMALL-OUTLINE PACKAGE

48 PINS SHOWN



- NOTES: A. All linear dimensions are in millimeters.
 B. This drawing is subject to change without notice.
 C. Body dimensions do not include mold protrusion not to exceed 0,15.
 D. Falls within JEDEC MO-153

IMPORTANT NOTICE

Texas Instruments Incorporated and its subsidiaries (TI) reserve the right to make corrections, enhancements, improvements and other changes to its semiconductor products and services per JESD46, latest issue, and to discontinue any product or service per JESD48, latest issue. Buyers should obtain the latest relevant information before placing orders and should verify that such information is current and complete. All semiconductor products (also referred to herein as "components") are sold subject to TI's terms and conditions of sale supplied at the time of order acknowledgment.

TI warrants performance of its components to the specifications applicable at the time of sale, in accordance with the warranty in TI's terms and conditions of sale of semiconductor products. Testing and other quality control techniques are used to the extent TI deems necessary to support this warranty. Except where mandated by applicable law, testing of all parameters of each component is not necessarily performed.

TI assumes no liability for applications assistance or the design of Buyers' products. Buyers are responsible for their products and applications using TI components. To minimize the risks associated with Buyers' products and applications, Buyers should provide adequate design and operating safeguards.

TI does not warrant or represent that any license, either express or implied, is granted under any patent right, copyright, mask work right, or other intellectual property right relating to any combination, machine, or process in which TI components or services are used. Information published by TI regarding third-party products or services does not constitute a license to use such products or services or a warranty or endorsement thereof. Use of such information may require a license from a third party under the patents or other intellectual property of the third party, or a license from TI under the patents or other intellectual property of TI.

Reproduction of significant portions of TI information in TI data books or data sheets is permissible only if reproduction is without alteration and is accompanied by all associated warranties, conditions, limitations, and notices. TI is not responsible or liable for such altered documentation. Information of third parties may be subject to additional restrictions.

Resale of TI components or services with statements different from or beyond the parameters stated by TI for that component or service voids all express and any implied warranties for the associated TI component or service and is an unfair and deceptive business practice. TI is not responsible or liable for any such statements.

Buyer acknowledges and agrees that it is solely responsible for compliance with all legal, regulatory and safety-related requirements concerning its products, and any use of TI components in its applications, notwithstanding any applications-related information or support that may be provided by TI. Buyer represents and agrees that it has all the necessary expertise to create and implement safeguards which anticipate dangerous consequences of failures, monitor failures and their consequences, lessen the likelihood of failures that might cause harm and take appropriate remedial actions. Buyer will fully indemnify TI and its representatives against any damages arising out of the use of any TI components in safety-critical applications.

In some cases, TI components may be promoted specifically to facilitate safety-related applications. With such components, TI's goal is to help enable customers to design and create their own end-product solutions that meet applicable functional safety standards and requirements. Nonetheless, such components are subject to these terms.

No TI components are authorized for use in FDA Class III (or similar life-critical medical equipment) unless authorized officers of the parties have executed a special agreement specifically governing such use.

Only those TI components which TI has specifically designated as military grade or "enhanced plastic" are designed and intended for use in military/aerospace applications or environments. Buyer acknowledges and agrees that any military or aerospace use of TI components which have **not** been so designated is solely at the Buyer's risk, and that Buyer is solely responsible for compliance with all legal and regulatory requirements in connection with such use.

TI has specifically designated certain components as meeting ISO/TS16949 requirements, mainly for automotive use. In any case of use of non-designated products, TI will not be responsible for any failure to meet ISO/TS16949.

Products

Audio	www.ti.com/audio
Amplifiers	amplifier.ti.com
Data Converters	dataconverter.ti.com
DLP® Products	www.dlp.com
DSP	dsp.ti.com
Clocks and Timers	www.ti.com/clocks
Interface	interface.ti.com
Logic	logic.ti.com
Power Mgmt	power.ti.com
Microcontrollers	microcontroller.ti.com
RFID	www.ti-rfid.com
OMAP Applications Processors	www.ti.com/omap
Wireless Connectivity	www.ti.com/wirelessconnectivity

Applications

Automotive and Transportation	www.ti.com/automotive
Communications and Telecom	www.ti.com/communications
Computers and Peripherals	www.ti.com/computers
Consumer Electronics	www.ti.com/consumer-apps
Energy and Lighting	www.ti.com/energy
Industrial	www.ti.com/industrial
Medical	www.ti.com/medical
Security	www.ti.com/security
Space, Avionics and Defense	www.ti.com/space-avionics-defense
Video and Imaging	www.ti.com/video

TI E2E Community

e2e.ti.com