

+3.3V Rising Edge Data Strobe LVDS Receiver 28-Bit Channel Link—66 MHz, +3.3V Rising Edge Strobe LVDS Receiver 21-Bit Channel Link—66 MHz

General Description

The DS90CR286A receiver converts the four LVDS data streams (Up to 1.848 Gbps throughput or 231 Megabytes/sec bandwidth) back into parallel 28 bits of CMOS/TTL data. Also available is the DS90CR216A that converts the three LVDS data streams (Up to 1.386 Gbps throughput or 173 Megabytes/sec bandwidth) back into parallel 21 bits of CMOS/TTL data. Both Receivers' outputs are Rising edge strobe.

Both devices are offered in TSSOP packages.

The DS90CR286A / DS90CR216A devices are enhanced over prior generation receivers and provided a wider data valid time on the receiver output.

This chipset is an ideal means to solve EMI and cable size problems associated with wide, high speed TTL interfaces.

- 50% duty cycle on receiver output clock
- Best-in-Class Set & Hold Times on RxOUTPUTs
- Rx power consumption <270 mW (typ) @66MHz Worst Case
- Rx Power-down mode <200µW (max)
- ESD rating >7 kV (HBM), >700V (EIAJ)
- PLL requires no external components
- Compatible with TIA/EIA-644 LVDS standard
- Low profile 56-lead or 48-lead TSSOP package
- Operating Temperature: -40°C to +85°C
- Automotive Q grade available - AEC-Q100 grade 3 qualified

Features

- 20 to 66 MHz shift clock support

Block Diagrams

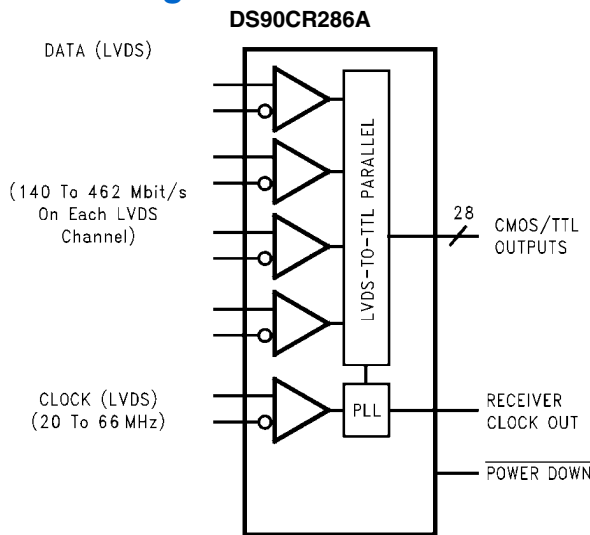

Order Number **DS90CR286AMTD, DS90CR286AQMT**
See NS Package Number MTD56

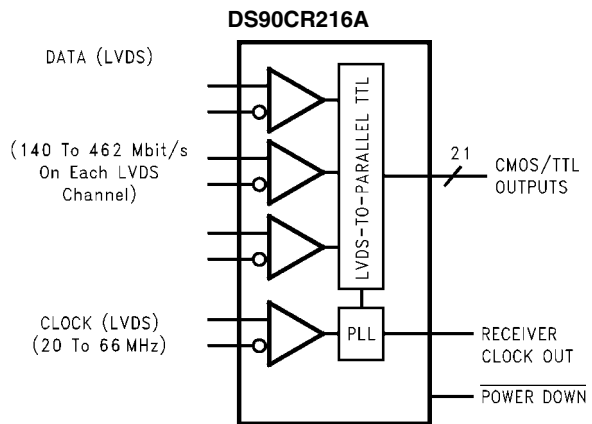

Order Number **DS90CR216AMTD**
See NS Package Number MTD48

Absolute Maximum Ratings (Note 1)

If Military/Aerospace specified devices are required, please contact the National Semiconductor Sales Office/Distributors for availability and specifications.

Supply Voltage (V_{CC})	-0.3V to +4V
CMOS/TTL Output Voltage	-0.3V to ($V_{CC} + 0.3V$)
LVDS Receiver Input Voltage	-0.3V to ($V_{CC} + 0.3V$)
Junction Temperature	+150°C
Storage Temperature	-65°C to +150°C
Lead Temperature (Soldering, 4 sec)	+260°C
Maximum Package Power Dissipation Capacity @ 25°C	
MTD56 (TSSOP) Package:	
DS90CR286AMTD	1.61 W
MTD48 (TSSOP) Package:	
DS90CR216AMTD	1.89 W
Package Derating:	

DS90CR286AMTD	12.4 mW/°C above +25°C
DS90CR216AMTD	15 mW/°C above +25°C
ESD Rating	
(HBM, 1.5 k Ω , 100 pF)	> 7 kV
(EIAJ, 0 Ω , 200 pF)	> 700V

Recommended Operating Conditions

	Min	No m	Max	Units
Supply Voltage (V_{CC})	3.0	3.3	3.6	V
Operating Free Air Temperature (T_A)	-40	+25	+85	°C
Receiver Input Range	0		2.4	V
Supply Noise Voltage (V_{CC})			100	mV _{pp}

Electrical Characteristics

Over recommended operating supply and temperature ranges unless otherwise specified.

Symbol	Parameter	Conditions	Min	Typ	Max	Units	
CMOS/TTL DC SPECIFICATIONS (For PowerDown Pin)							
V_{IH}	High Level Input Voltage		2.0		V_{CC}	V	
V_{IL}	Low Level Input Voltage		GND		0.8	V	
V_{CL}	Input Clamp Voltage	$I_{CL} = -18$ mA		-0.79	-1.5	V	
I_{IN}	Input Current	$V_{IN} = 0.4V, 2.5V$ or V_{CC}		+1.8	+10	μ A	
		$V_{IN} = GND$	-10	0		μ A	
CMOS/TTL DC SPECIFICATIONS							
V_{OH}	High Level Output Voltage	$I_{OH} = -0.4$ mA	2.7	3.3		V	
V_{OL}	Low Level Output Voltage	$I_{OL} = 2$ mA		0.06	0.3	V	
I_{OS}	Output Short Circuit Current	$V_{OUT} = 0V$		-60	-120	mA	
LVDS RECEIVER DC SPECIFICATIONS							
V_{TH}	Differential Input High Threshold	$V_{CM} = +1.2V$			+100	mV	
V_{TL}	Differential Input Low Threshold			-100			mV
I_{IN}	Input Current	$V_{IN} = +2.4V, V_{CC} = 3.6V$			± 10	μ A	
		$V_{IN} = 0V, V_{CC} = 3.6V$			± 10	μ A	
RECEIVER SUPPLY CURRENT							
ICCRW	Receiver Supply Current Worst Case	$C_L = 8$ pF, Worst Case Pattern, DS90CR286A (Figures 1, 2), $T_A = -10^\circ C$ to $+70^\circ C$	$f = 33$ MHz		49	65	mA
			$f = 37.5$ MHz		53	70	mA
			$f = 66$ MHz		81	105	mA
ICCRW	Receiver Supply Current Worst Case	$C_L = 8$ pF, Worst Case Pattern, DS90CR286A (Figures 1, 2), $T_A = -40^\circ C$ to $+85^\circ C$	$f = 40$ MHz		53	70	mA
			$f = 66$ MHz		81	105	mA
ICCRW	Receiver Supply Current Worst Case	$C_L = 8$ pF, Worst Case Pattern, DS90CR216A (Figures 1, 2), $T_A = -10^\circ C$ to $+70^\circ C$	$f = 33$ MHz		49	55	mA
			$f = 37.5$ MHz		53	60	mA
			$f = 66$ MHz		78	90	mA
ICCRW	Receiver Supply Current Worst Case	$C_L = 8$ pF, Worst Case Pattern, DS90CR216A (Figures 1, 2), $T_A = -40^\circ C$ to $+85^\circ C$	$f = 40$ MHz		53	60	mA
			$f = 66$ MHz		78	90	mA

Symbol	Parameter	Conditions	Min	Typ	Max	Units
ICCRZ	Receiver Supply Current Power Down	Power Down = Low Receiver Outputs Stay Low during Power Down Mode		10	55	μA

Note 1: "Absolute Maximum Ratings" are those values beyond which the safety of the device cannot be guaranteed. They are not meant to imply that the device should be operated at these limits. The tables of "Electrical Characteristics" specify conditions for device operation.

Note 2: Typical values are given for $V_{CC} = 3.3V$ and $T_A = +25C$.

Note 3: Current into device pins is defined as positive. Current out of device pins is defined as negative. Voltages are referenced to ground unless otherwise specified (except V_{OD} and ΔV_{OD}).

Receiver Switching Characteristics

Over recommended operating supply and temperature ranges unless otherwise specified

Symbol	Parameter	Min	Typ	Max	Units	
CLHT	CMOS/TTL Low-to-High Transition Time (Figure 2)		2	5	ns	
CHLT	CMOS/TTL High-to-Low Transition Time (Figure 2)		1.8	5	ns	
RSPos0	Receiver Input Strobe Position for Bit 0 (Figure 9, Figure 10)	f = 40 MHz	1.0	1.4	2.15	ns
RSPos1	Receiver Input Strobe Position for Bit 1		4.5	5.0	5.8	ns
RSPos2	Receiver Input Strobe Position for Bit 2		8.1	8.5	9.15	ns
RSPos3	Receiver Input Strobe Position for Bit 3		11.6	11.9	12.6	ns
RSPos4	Receiver Input Strobe Position for Bit 4		15.1	15.6	16.3	ns
RSPos5	Receiver Input Strobe Position for Bit 5		18.8	19.2	19.9	ns
RSPos6	Receiver Input Strobe Position for Bit 6		22.5	22.9	23.6	ns
RSPos0	Receiver Input Strobe Position for Bit 0 (Figure 9, Figure 10)	f = 66 MHz	0.7	1.1	1.4	ns
RSPos1	Receiver Input Strobe Position for Bit 1		2.9	3.3	3.6	ns
RSPos2	Receiver Input Strobe Position for Bit 2		5.1	5.5	5.8	ns
RSPos3	Receiver Input Strobe Position for Bit 3		7.3	7.7	8.0	ns
RSPos4	Receiver Input Strobe Position for Bit 4		9.5	9.9	10.2	ns
RSPos5	Receiver Input Strobe Position for Bit 5		11.7	12.1	12.4	ns
RSPos6	Receiver Input Strobe Position for Bit 6		13.9	14.3	14.6	ns
RSKM	RxIN Skew Margin (Note 4) (Figure 11)	f = 40 MHz	490			ps
		f = 66 MHz	400			ps
RCOP	RxCLK OUT Period (Figure 3)		15	T	50	ns
RCOH	RxCLK OUT High Time (Figure 3)	f = 40 MHz	10.0	12.2		ns
RCOL	RxCLK OUT Low Time (Figure 3)		10.0	11.0		ns
RSRC	RxOUT Setup to RxCLK OUT (Figure 3)		6.5	11.6		ns
RHRC	RxOUT Hold to RxCLK OUT (Figure 3)		6.0	11.6		ns
RCOH	RxCLK OUT High Time (Figure 3)	f = 66 MHz	5.0	7.6		ns
RCOL	RxCLK OUT Low Time (Figure 3)		5.0	6.3		ns
RSRC	RxOUT Setup to RxCLK OUT (Figure 3)		4.5	7.3		ns
RHRC	RxOUT Hold to RxCLK OUT (Figure 3)		4.0	6.3		ns
RCCD	RxCLK IN to RxCLK OUT Delay @ 25°C, $V_{CC} = 3.3V$ (Note 5)(Figure 4)		3.5	5.0	7.5	ns
RPLLS	Receiver Phase Lock Loop Set (Figure 5)				10	ms
RPDD	Receiver Power Down Delay (Figure 8)				1	μs

Note 4: Receiver Skew Margin is defined as the valid data sampling region at the receiver inputs. This margin takes into account the transmitter pulse positions (min and max) and the receiver input setup and hold time (internal data sampling window - RSPos). This margin allows for LVDS interconnect skew, inter-symbol interference (both dependent on type/length of cable), and clock jitter (less than 250 ps).

Note 5: Total latency for the channel link chipset is a function of clock period and gate delays through the transmitter (TCCD) and receiver (RCCD). The total latency for the 215/285 transmitter and 216A/286A receiver is: $(T + TCCD) + (2 \cdot T + RCCD)$, where T = Clock period.

AC Timing Diagrams

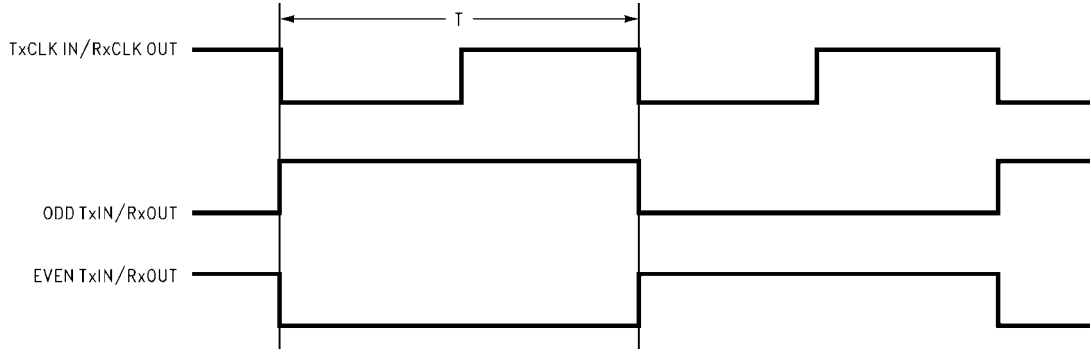

10087302

FIGURE 1. "Worst Case" Test Pattern

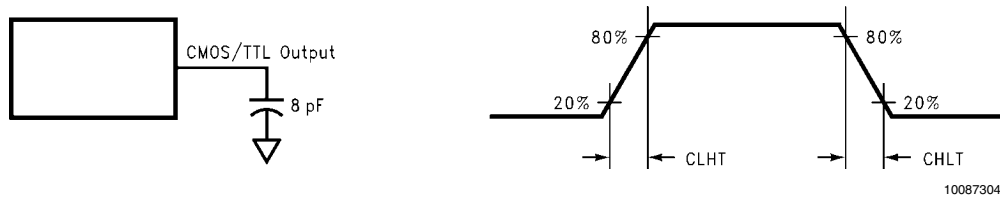

10087304

FIGURE 2. DS90CR286A/DS90CR216A (Receiver) CMOS/TTL Output Load and Transition Times

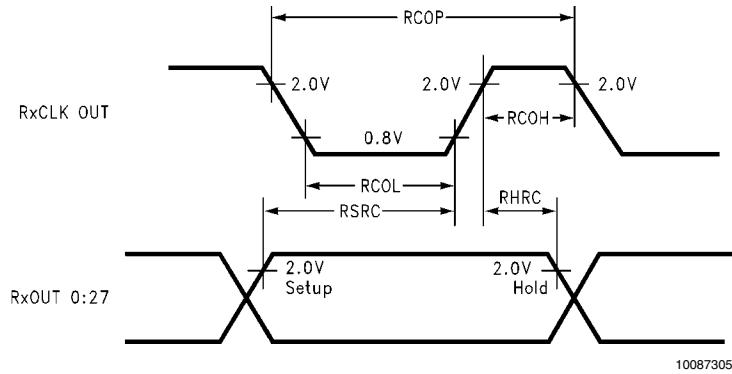

10087305

FIGURE 3. DS90CR286A/DS90CR216A (Receiver) Setup/Hold and High/Low Times

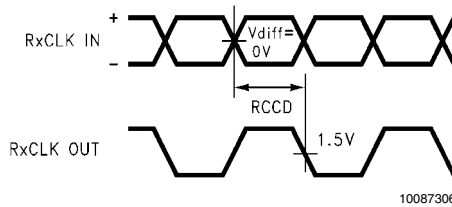

10087306

FIGURE 4. DS90CR286A/DS90CR216A (Receiver) Clock In to Clock Out Delay

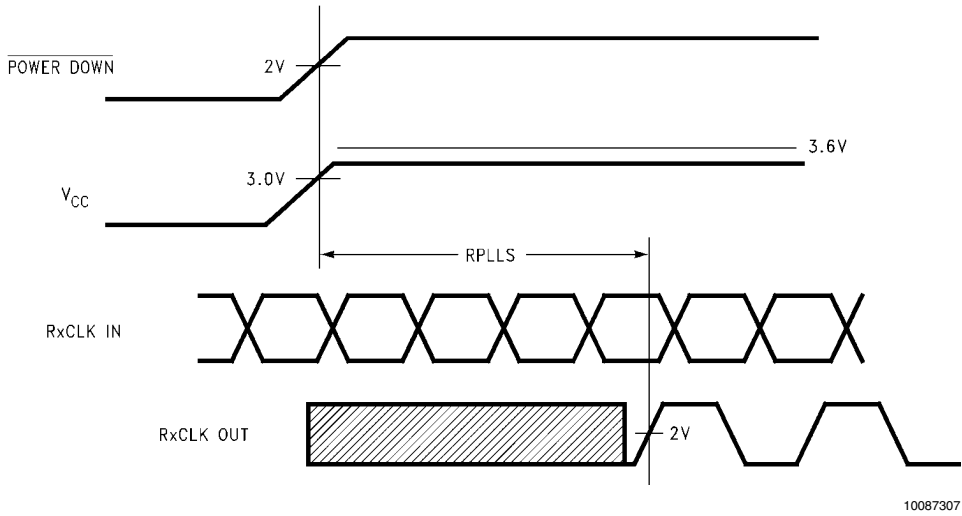

FIGURE 5. DS90CR286A/DS90CR216A (Receiver) Phase Lock Loop Set Time

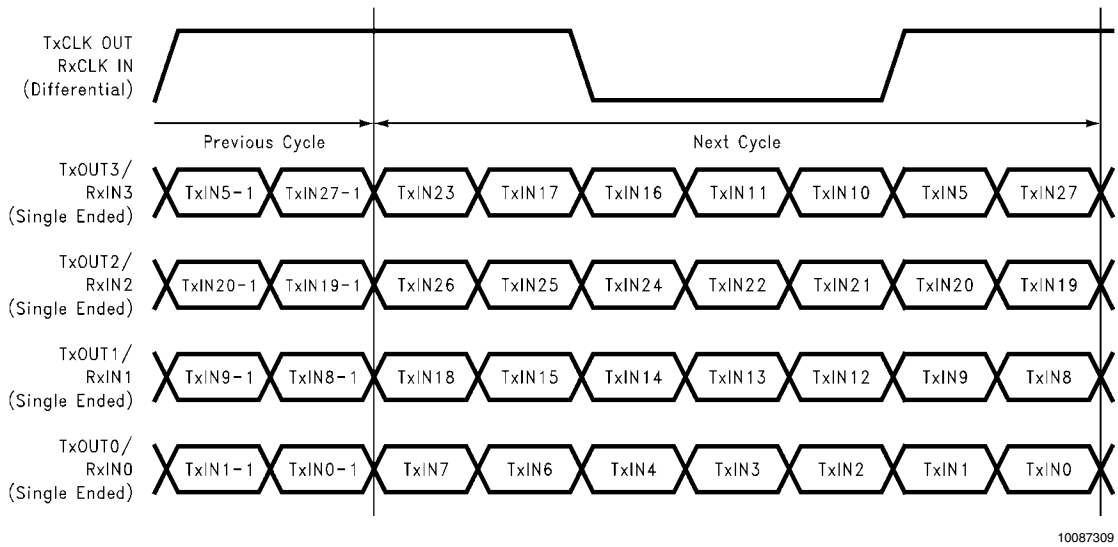

FIGURE 6. 28 Parallel TTL Data Inputs Mapped to LVDS Outputs - DS90CR286A

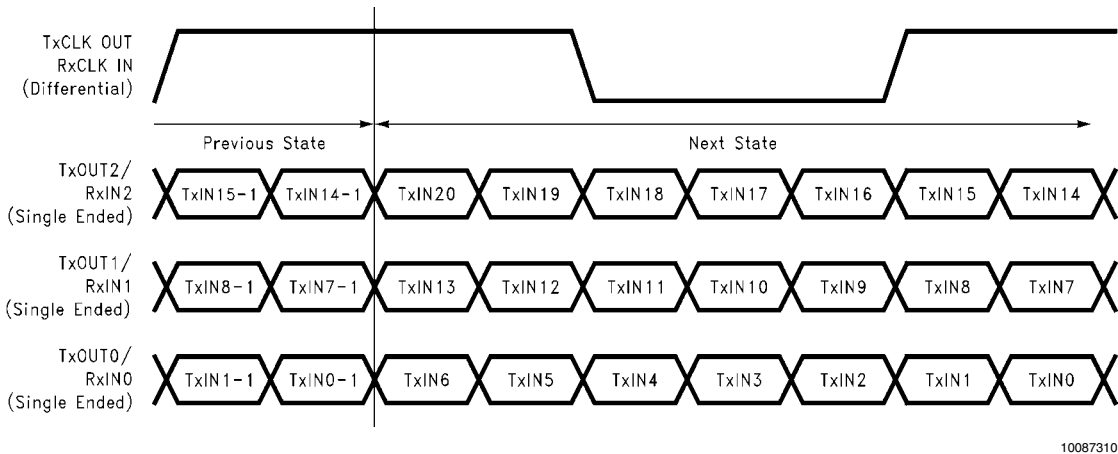

FIGURE 7. 21 Parallel TTL Data Inputs Mapped to LVDS Outputs - DS90CR216A

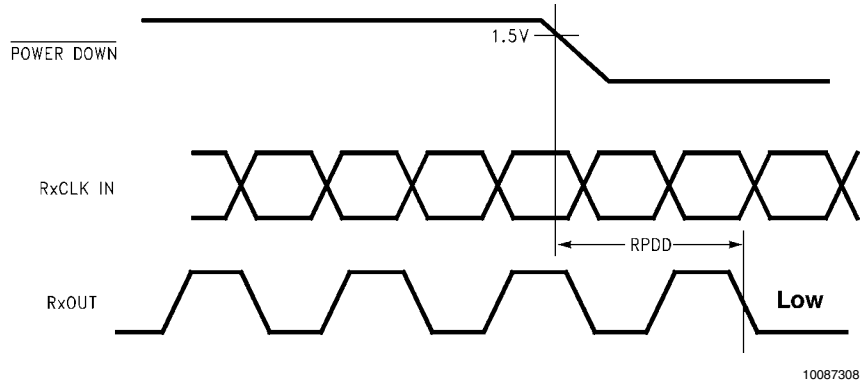
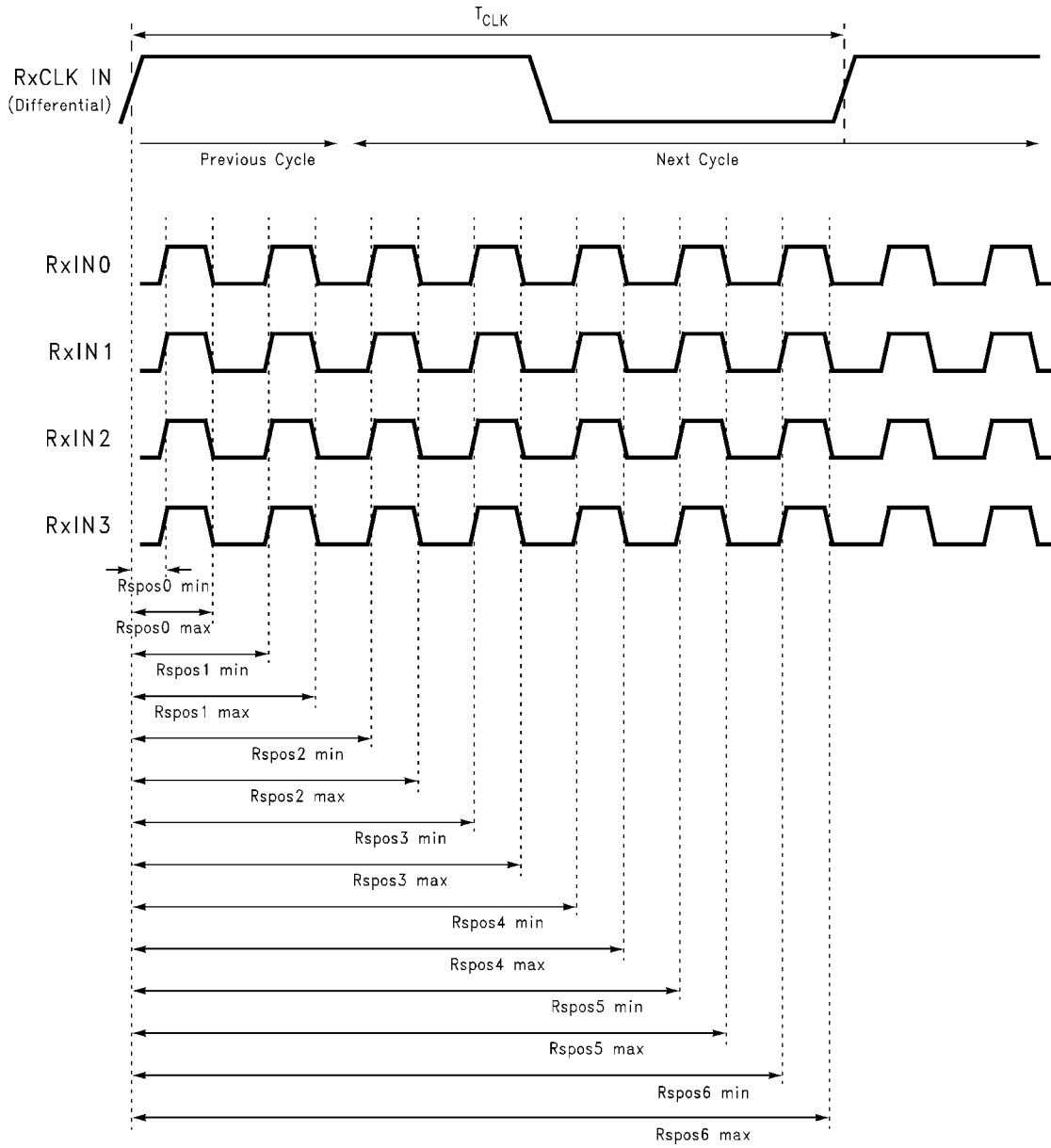
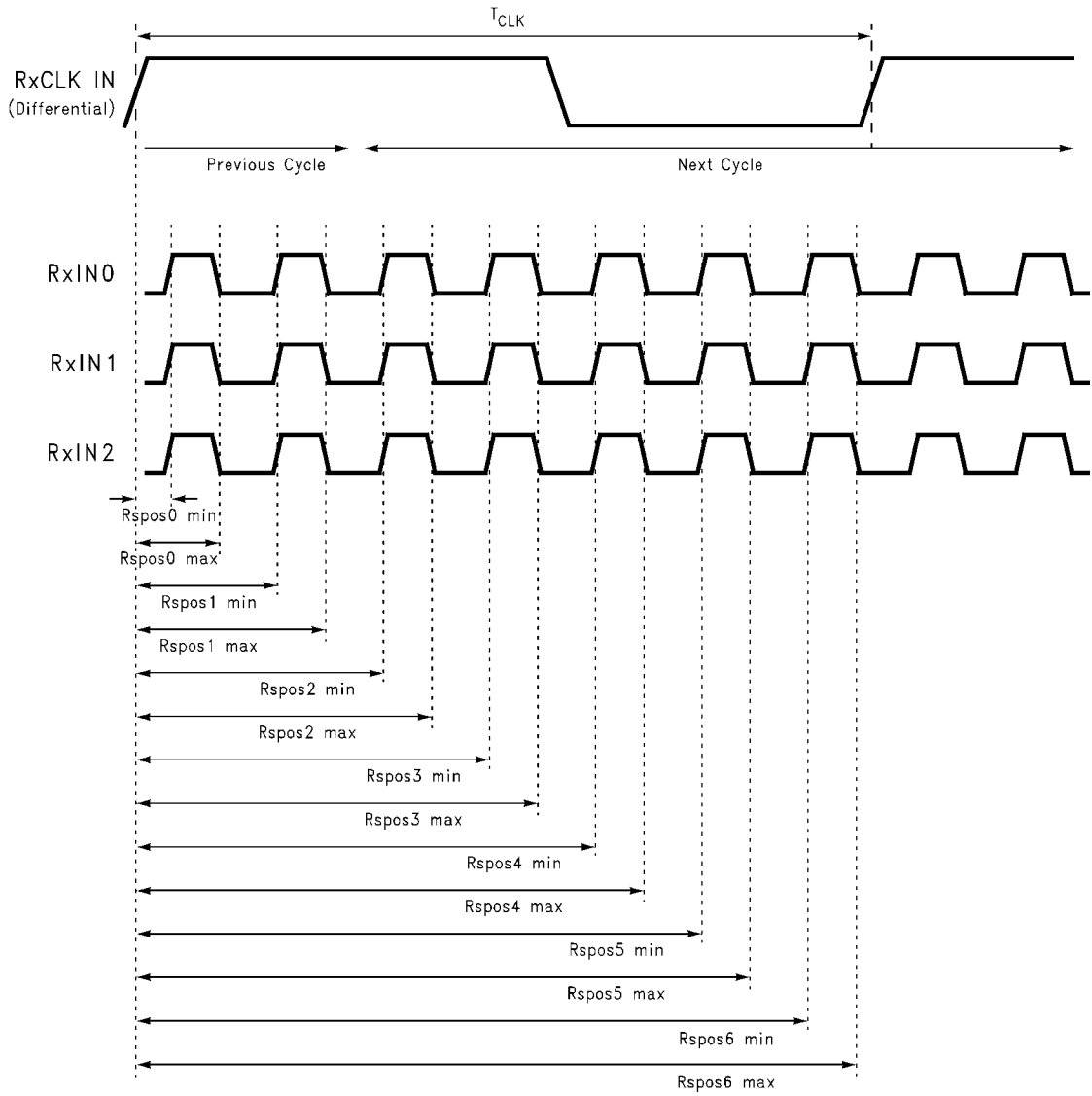

FIGURE 8. DS90CR286A/DS90CR216A (Receiver) Power Down Delay



10087325

FIGURE 9. DS90CR286A (Receiver) LVDS Input Strobe Position



10087326

FIGURE 10. DS90CR216A (Receiver) LVDS Input Strobe Position

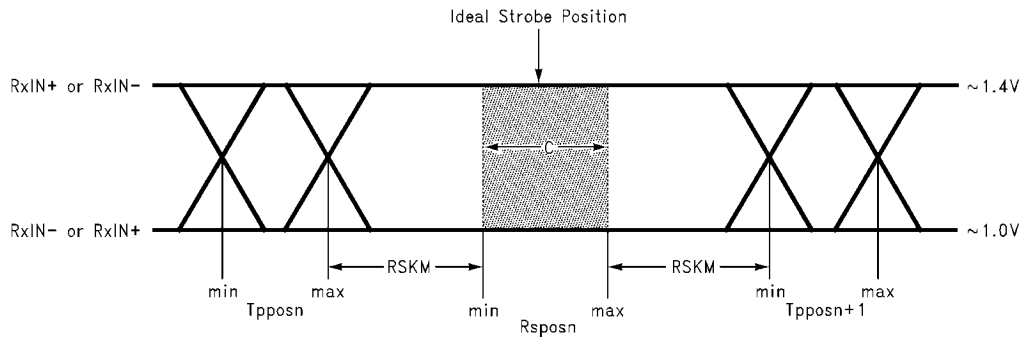

10087311

C—Setup and Hold Time (Internal data sampling window) defined by Rspostn (receiver input strobe position) min and max

Tppos—Transmitter output pulse position (min and max)

RSKM = Cable Skew (type, length) + Source Clock Jitter (cycle to cycle) (Note: Cycle-to-cycle jitter is less than TBD ps at 66 MHz.) + ISI (Inter-symbol interference) (Note: ISI is dependent on interconnect length; may be zero.)

Cable Skew—typically 10 ps–40 ps per foot, media dependent

Note 6: Cycle-to-cycle jitter is less than TBD ps at 66 MHz.

Note 7: ISI is dependent on interconnect length; may be zero.

FIGURE 11. Receiver LVDS Input Skew Margin

DS90CR286A Pin Descriptions — MTD56 Package — 28-Bit Channel Link Receiver

Pin Name	I/O	No	Description
RxIN+	I	4	Positive LVDS differential data inputs.
RxIN-	I	4	Negative LVDS differential data inputs.
RxOUT	O	28	TTL level data outputs.
RxCLK IN+	I	1	Positive LVDS differential clock input.
RxCLK IN-	I	1	Negative LVDS differential clock input.
RxCLK OUT	O	1	TTL level clock output. The rising edge acts as data strobe.
PWR DOWN	I	1	TTL level input. When asserted (low input) the receiver outputs are low.
V _{CC}	I	4	Power supply pins for TTL outputs.
GND	I	5	Ground pins for TTL outputs.
PLL V _{CC}	I	1	Power supply for PLL.
PLL GND	I	2	Ground pin for PLL.
LVDS V _{CC}	I	1	Power supply pin for LVDS inputs.
LVDS GND	I	3	Ground pins for LVDS inputs.

DS90CR216A Pin Descriptions — MTD48 Package — 21-Bit Channel Link Receiver

Pin Name	I/O	No	Description
RxIN+	I	3	Positive LVDS differential data inputs. (Note 8)
RxIN-	I	3	Negative LVDS differential data inputs. (Note 8)
RxOUT	O	21	TTL level data outputs.
RxCLK IN+	I	1	Positive LVDS differential clock input.
RxCLK IN-	I	1	Negative LVDS differential clock input.
RxCLK OUT	O	1	TTL level clock output. The rising edge acts as data strobe.
PWR DOWN	I	1	TTL level input. When asserted (low input) the receiver outputs are low.
V _{CC}	I	4	Power supply pins for TTL outputs.
GND	I	5	Ground pins for TTL outputs.
PLL V _{CC}	I	1	Power supply for PLL.
PLL GND	I	2	Ground pin for PLL.
LVDS V _{CC}	I	1	Power supply pin for LVDS inputs.
LVDS GND	I	3	Ground pins for LVDS inputs.

Note 8: These receivers have input failsafe bias circuitry to guarantee a stable receiver output for floating or terminated receiver inputs. Under these conditions receiver inputs will be in a HIGH state. If a clock signal is present, outputs will all be HIGH; if the clock input is also floating/terminated outputs will remain in the last valid state. A floating/terminated clock input will result in a LOW clock output.

Pin Diagram for TSSOP Packages

DS90CR286AMTD

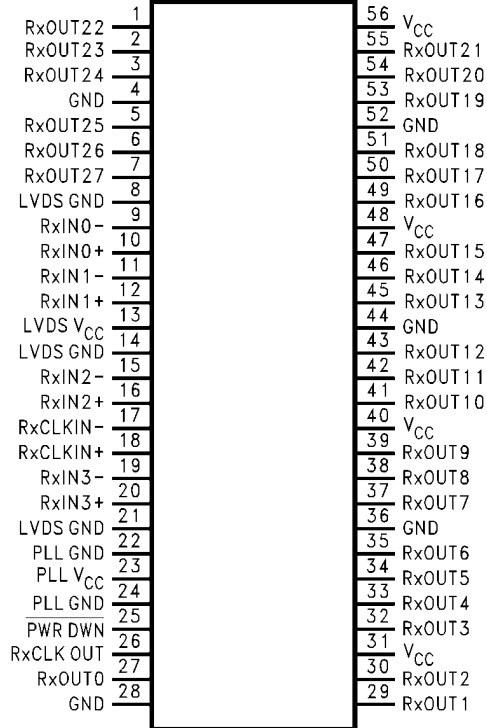

10087323

DS90CR216AMTD

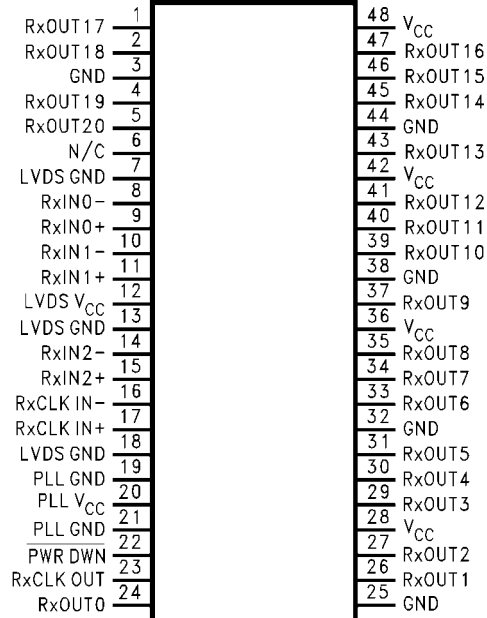

10087313

Physical Dimensions inches (millimeters) unless otherwise noted

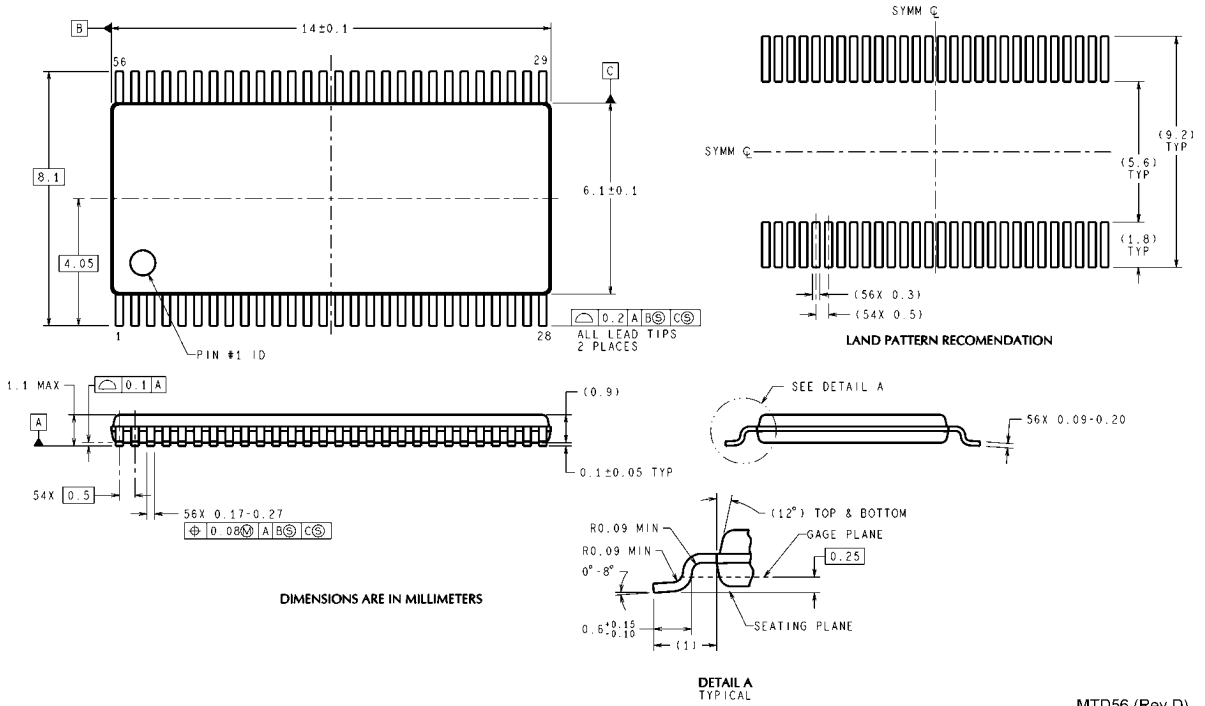

MTD56 (Rev D)

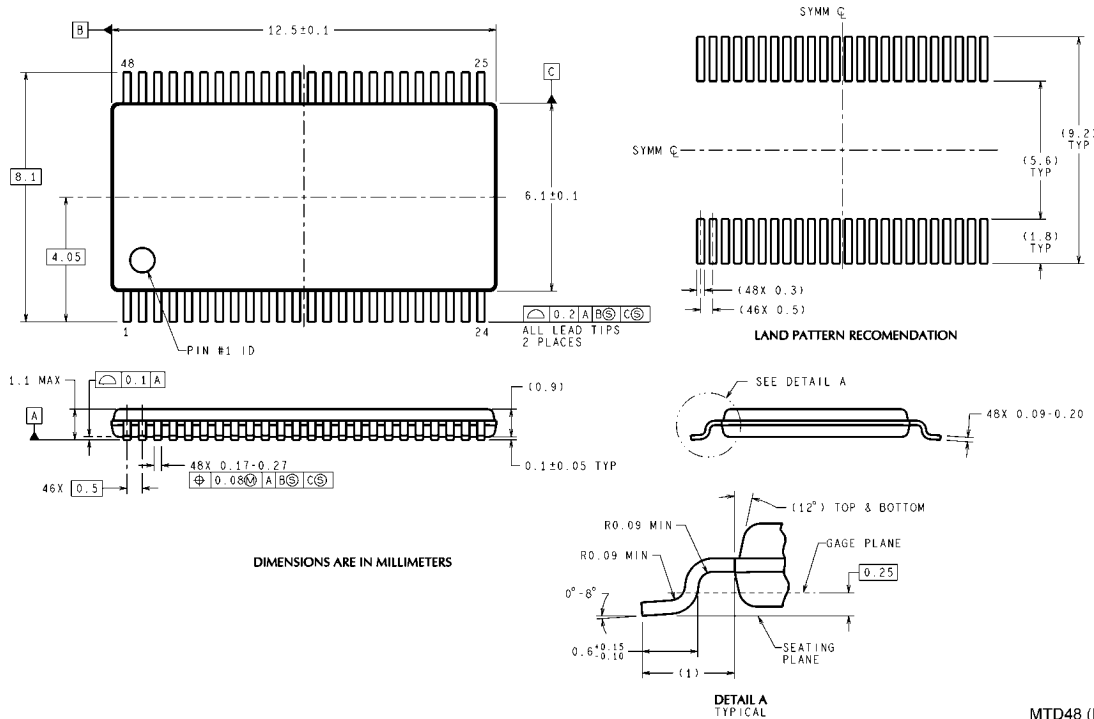

MTD48 (Rev E)

Notes

Notes

For more National Semiconductor product information and proven design tools, visit the following Web sites at:

Products		Design Support	
Amplifiers	www.national.com/amplifiers	WEBENCH® Tools	www.national.com/webench
Audio	www.national.com/audio	App Notes	www.national.com/appnotes
Clock and Timing	www.national.com/timing	Reference Designs	www.national.com/refdesigns
Data Converters	www.national.com/adc	Samples	www.national.com/samples
Interface	www.national.com/interface	Eval Boards	www.national.com/evalboards
LVDS	www.national.com/lvds	Packaging	www.national.com/packaging
Power Management	www.national.com/power	Green Compliance	www.national.com/quality/green
Switching Regulators	www.national.com/switchers	Distributors	www.national.com/contacts
LDOs	www.national.com/ldo	Quality and Reliability	www.national.com/quality
LED Lighting	www.national.com/led	Feedback/Support	www.national.com/feedback
Voltage Reference	www.national.com/vref	Design Made Easy	www.national.com/easy
PowerWise® Solutions	www.national.com/powerwise	Solutions	www.national.com/solutions
Serial Digital Interface (SDI)	www.national.com/sdi	Mil/Aero	www.national.com/milaero
Temperature Sensors	www.national.com/tempsensors	SolarMagic™	www.national.com/solarmagic
Wireless (PLL/VCO)	www.national.com/wireless	Analog University®	www.national.com/AU

THE CONTENTS OF THIS DOCUMENT ARE PROVIDED IN CONNECTION WITH NATIONAL SEMICONDUCTOR CORPORATION ("NATIONAL") PRODUCTS. NATIONAL MAKES NO REPRESENTATIONS OR WARRANTIES WITH RESPECT TO THE ACCURACY OR COMPLETENESS OF THE CONTENTS OF THIS PUBLICATION AND RESERVES THE RIGHT TO MAKE CHANGES TO SPECIFICATIONS AND PRODUCT DESCRIPTIONS AT ANY TIME WITHOUT NOTICE. NO LICENSE, WHETHER EXPRESS, IMPLIED, ARISING BY ESTOPPEL OR OTHERWISE, TO ANY INTELLECTUAL PROPERTY RIGHTS IS GRANTED BY THIS DOCUMENT.

TESTING AND OTHER QUALITY CONTROLS ARE USED TO THE EXTENT NATIONAL DEEMS NECESSARY TO SUPPORT NATIONAL'S PRODUCT WARRANTY. EXCEPT WHERE MANDATED BY GOVERNMENT REQUIREMENTS, TESTING OF ALL PARAMETERS OF EACH PRODUCT IS NOT NECESSARILY PERFORMED. NATIONAL ASSUMES NO LIABILITY FOR APPLICATIONS ASSISTANCE OR BUYER PRODUCT DESIGN. BUYERS ARE RESPONSIBLE FOR THEIR PRODUCTS AND APPLICATIONS USING NATIONAL COMPONENTS. PRIOR TO USING OR DISTRIBUTING ANY PRODUCTS THAT INCLUDE NATIONAL COMPONENTS, BUYERS SHOULD PROVIDE ADEQUATE DESIGN, TESTING AND OPERATING SAFEGUARDS.

EXCEPT AS PROVIDED IN NATIONAL'S TERMS AND CONDITIONS OF SALE FOR SUCH PRODUCTS, NATIONAL ASSUMES NO LIABILITY WHATSOEVER, AND NATIONAL DISCLAIMS ANY EXPRESS OR IMPLIED WARRANTY RELATING TO THE SALE AND/OR USE OF NATIONAL PRODUCTS INCLUDING LIABILITY OR WARRANTIES RELATING TO FITNESS FOR A PARTICULAR PURPOSE, MERCHANTABILITY, OR INFRINGEMENT OF ANY PATENT, COPYRIGHT OR OTHER INTELLECTUAL PROPERTY RIGHT.

LIFE SUPPORT POLICY

NATIONAL'S PRODUCTS ARE NOT AUTHORIZED FOR USE AS CRITICAL COMPONENTS IN LIFE SUPPORT DEVICES OR SYSTEMS WITHOUT THE EXPRESS PRIOR WRITTEN APPROVAL OF THE CHIEF EXECUTIVE OFFICER AND GENERAL COUNSEL OF NATIONAL SEMICONDUCTOR CORPORATION. As used herein:

Life support devices or systems are devices which (a) are intended for surgical implant into the body, or (b) support or sustain life and whose failure to perform when properly used in accordance with instructions for use provided in the labeling can be reasonably expected to result in a significant injury to the user. A critical component is any component in a life support device or system whose failure to perform can be reasonably expected to cause the failure of the life support device or system or to affect its safety or effectiveness.

National Semiconductor and the National Semiconductor logo are registered trademarks of National Semiconductor Corporation. All other brand or product names may be trademarks or registered trademarks of their respective holders.

Copyright© 2009 National Semiconductor Corporation

For the most current product information visit us at www.national.com



National Semiconductor Americas Technical Support Center
 Email: support@nsc.com
 Tel: 1-800-272-9959

National Semiconductor Europe Technical Support Center
 Email: europe.support@nsc.com

National Semiconductor Asia Pacific Technical Support Center
 Email: ap.support@nsc.com

National Semiconductor Japan Technical Support Center
 Email: jpn.feedback@nsc.com