

DS3695A/DS3695AT/DS3696A Multipoint RS485/RS422 Transceivers

General Description

The DS3695A and DS3696A are high speed differential TRI-STATE[®] bus/line transceivers designed to meet the requirements of EIA standard RS485 with extended common mode range (+12V to -7V), for multipoint data transmission. In addition they are compatible with requirements of RS-422.

The driver and receiver outputs feature TRI-STATE capability. The driver outputs remain in TRI-STATE over the entire common mode range of +12V to -7V. Bus faults that cause excessive power dissipation within the device trigger a thermal shutdown circuit, which forces the driver outputs into the high impedance state. The DS3696A provides an output pin (TS) which reports the thermal shutdown of the device. TS is an "open collector" pin with an internal 10 kΩ pull-up resistor. This allows the TS outputs of several devices to be wire OR-ed.

Both AC and DC specifications are guaranteed over the 0°C to 70°C temperature and 4.75V to 5.25V supply voltage range.

Features

- Meets EIA standard RS485 for multipoint bus transmission and is compatible with RS-422
- 10 ns driver propagation delays (typical)
- Single +5V supply
- -7V to +12V bus common mode range permits ±7V ground difference between devices on the bus
- Thermal shutdown protection
- High impedance to bus with driver in TRI-STATE or with power off, over the entire common mode range allows the unused devices on the bus to be powered down
- Combined impedance of a driver output and receiver input is less than one RS485 unit load, allowing up to 32 transceivers on the bus
- 70 mV typical receiver hysteresis
- Available in SOIC packaging

Connection and Logic Diagram

Molded Package, Small Outline (M)

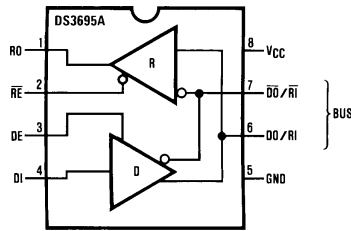

Top View

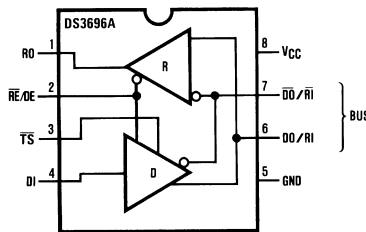

\overline{TS} was \overline{LF} (Line Fault) on previous datasheets, \overline{TS} goes low upon thermal shutdown.

Top View

Order Number DS3695AM, DS3695ATM or DS3696AM
See NS Package Number M08A

TRI-STATE[®] is a registered trademark of National Semiconductor Corporation.

Absolute Maximum Ratings (Note 1)

If Military/Aerospace specified devices are required, please contact the National Semiconductor Sales Office/Distributors for availability and specifications.

Supply Voltage, V_{CC}	7V
Control Input Voltages	7V
Driver Input Voltage	7V
Driver Output Voltages	+15V/-10V
Receiver Input Voltages	+15V/-10V
Receiver Output Voltage	5.5V
Continuous Power Dissipation 25°C	
M Package	630 mW (Note 4)
Storage Temp. Range	-65°C to +150°C

Lead Temp. (Soldering 4 seconds)

260°C

Recommended Operating Conditions

	Min	Max	Units
Supply Voltage, V_{CC}	4.75	5.25	V
Bus Voltage	-7	+12	V
Operating Free Air Temp. (T_A)			
Commercial (DS3695AM)	0	+70	°C
Industrial (DS3695ATM)	-40	+85	°C
Commercial (DS3696AM)	0	+70	°C

Electrical Characteristics (Notes 2, 3)

0°C ≤ T_A ≤ 70°C, 4.75V < V_{CC} < 5.25V unless otherwise specified

Symbol	Parameter	Conditions	Min	Typ	Max	Units	
V_{OD1}	Differential Driver Output Voltage (Unloaded)	$I_O = 0$			5	V	
V_{OD2}	Differential Driver Output Voltage (with Load)	R = 50Ω; (RS-422) (Note 5)	2			V	
		R = 27Ω; (RS-485)	1.5			V	
ΔV_{OD}	Change in Magnitude of Driver Differential Output Voltage For Complementary Output States	R = 27Ω			0.2	V	
V_{OC}	Driver Common Mode Output Voltage				3.0	V	
$\Delta V_{OCl} $	Change in Magnitude of Driver Common Mode Output Voltage For Complementary Output States				0.2	V	
V_{IH}	Input High Voltage	DI, DE, RE, RE/DE	2			V	
V_{IL}	Input Low Voltage				0.8	V	
V_{CL}	Input Clamp Voltage		$I_{IN} = -18$ mA			-1.5	V
I_{IL}	Input Low Current		$V_{IL} = 0.4$ V			-200	μA
I_{IH}	Input High Current		$V_{IH} = 2.4$ V			20	μA
I_{IN}	Input Current	DO/RI, DO/RI RI, RI	$V_{CC} = 0$ V or 5.25V DE or RE/DE = 0V	$V_{IN} = 12$ V		+1.0	mA
				$V_{IN} = -7$ V		-0.8	mA
V_{TH}	Differential Input Threshold Voltage for Receiver	$-7V \leq V_{CM} \leq +12V$	-0.2		+0.2	V	
ΔV_{TH}	Receiver Input Hysteresis	$V_{CM} = 0$ V		70		mV	
V_{OH}	Receiver Output High Voltage	$I_{OH} = -400$ μA	2.4			V	
V_{OL}	Output Low Voltage	RO			0.5	V	
		TS			0.45	V	
I_{OZR}	OFF-State (High Impedance) Output Current at Receiver	$V_{CC} = \text{Max}$ $0.4V \leq V_O \leq 2.4V$			±20	μA	
R_{IN}	Receiver Input Resistance	$-7V \leq V_{CM} \leq +12V$	12			kΩ	
I_{CC}	Supply Current	No Load (Note 5)	Driver Outputs Enabled	42	60	mA	
			Driver Outputs Disabled	27	40	mA	
I_{OSD}	Driver Short-Circuit Output Current	$V_O = -7$ V (Note 5)			-250	mA	
		$V_O = +12$ V (Note 5)			+250	mA	
I_{OSR}	Receiver Short-Circuit Output Current	$V_O = 0$ V	-15		-85	mA	

Note 1: "Absolute maximum ratings" are those beyond which the safety of the device cannot be guaranteed. They are not meant to imply that the device should be operated at these limits. The tables of "Electrical Characteristics" provide conditions for actual device operation.

Electrical Characteristics (Notes 2, 3) (Continued)

Note 2: All currents into device pins are positive; all currents out of device pins are negative. All voltages are referenced to device ground unless otherwise specified.

Note 3: All typicals are given for $V_{CC} = 5V$ and $T_A = 25^\circ C$.

Note 4: Derate linearly at $6.5 \text{ mW}/^\circ C$ to 337 mW at $70^\circ C$.

Note 5: All limits for which Note 5 is applied must be derated by 10% for DS3695AT. Other parameters remain the same for this extended temperature range device ($-40^\circ C \leq T_A \leq +85^\circ C$).

Switching Characteristics

$0^\circ C \leq T_A \leq 70^\circ C$, $4.75V < V_{CC} < 5.25V$ unless otherwise specified (Note 3)

Receiver Switching Characteristics

(Figures 1, 2 and Figure 3)

Symbol	Conditions	Min	Typ	Max	Units
t_{PLH}	$C_L = 15 \text{ pF}$	15	28	42	ns
t_{PHL}	S1 and S2	15	28	42	ns
$ t_{PLH} - t_{PHL} $	Closed	0	3		ns
t_{PLZ}	$C_L = 15 \text{ pF}$, S2 Open	5	29	35	ns
t_{PHZ}	$C_L = 15 \text{ pF}$, S1 Open	5	12	16	ns
t_{PZL}	$C_L = 15 \text{ pF}$, S2 Open	7	15	28	ns
t_{PZH}	$C_L = 15 \text{ pF}$, S1 Open	7	15	20	ns

Driver Switching Characteristics

Symbol	Conditions	Min	Typ	Max	Units
SINGLE ENDED CHARACTERISTICS (Figures 4, 5 and Figure 7)					
t_{PLH}	$R_{LDIFF} = 60\Omega$	9	15	22	ns
t_{PHL}	$C_{L1} = C_{L2} = 100 \text{ pF}$	9	15	22	ns
$t_{SKEW} t_{PLH} - t_{PHL} $		0	2	8	ns
t_{PLZ}	$C_L = 15 \text{ pF}$, S2 Open	7	15	30	ns
t_{PHZ}	$C_L = 15 \text{ pF}$, S1 Open	7	15	30	ns
t_{PZL}	$C_L = 100 \text{ pF}$, S2 Open	30	35	50	ns
t_{PZH}	$C_L = 100 \text{ pF}$, S1 Open	30	35	50	ns
DIFFERENTIAL SWITCHING CHARACTERISTICS (Figure 7)					
t_r, t_f	$R_{LDIFF} = 60\Omega$ $C_{L1} = C_{L2} = 100 \text{ pF}$	6	10	18	ns

AC Test Circuits and Switching Waveforms

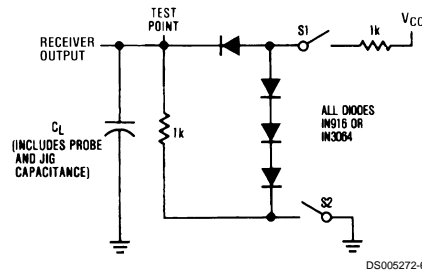
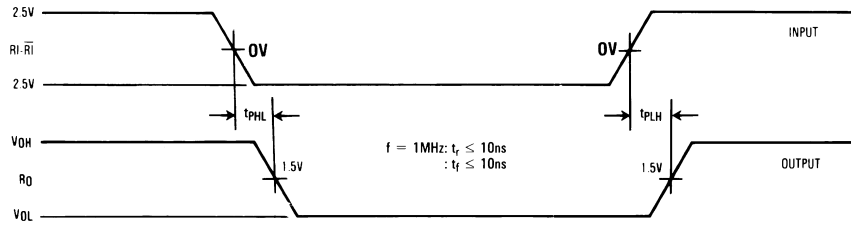

FIGURE 1. Receiver Propagation Delay Test Circuit

AC Test Circuits and Switching Waveforms (Continued)



DS005272-7

Differential input voltage may be realized by grounding \overline{Ri} and pulsing Ri between +2.5V and -2.5V

FIGURE 2. Receiver Input-to-Output Propagation Delay Timing

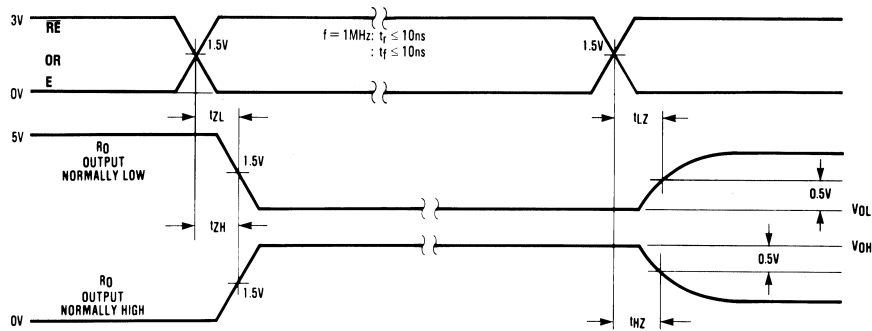

DS005272-8

FIGURE 3. Receiver Enable/Disable Propagation Delay Timing

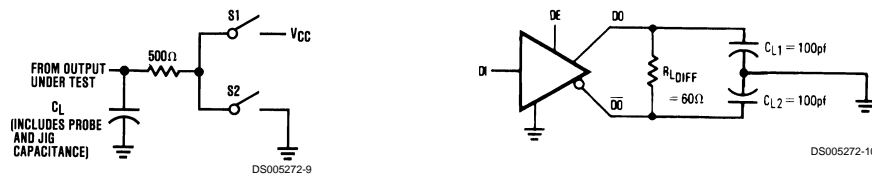

DS005272-10

Unless otherwise specified the switches are closed.

FIGURE 4. Driver Propagation Delay Test Circuits

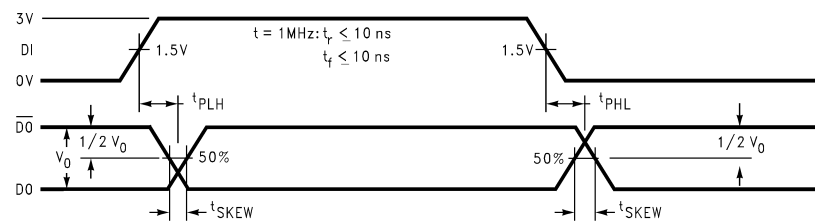

DS005272-11

t_{PLH} and t_{PHL} are measured to the respective 50% points. t_{SKEW} is the difference between propagation delays of the complementary outputs.

FIGURE 5. Driver Input-to-Output Propagation Delay Timing (Single-Ended)

AC Test Circuits and Switching Waveforms (Continued)

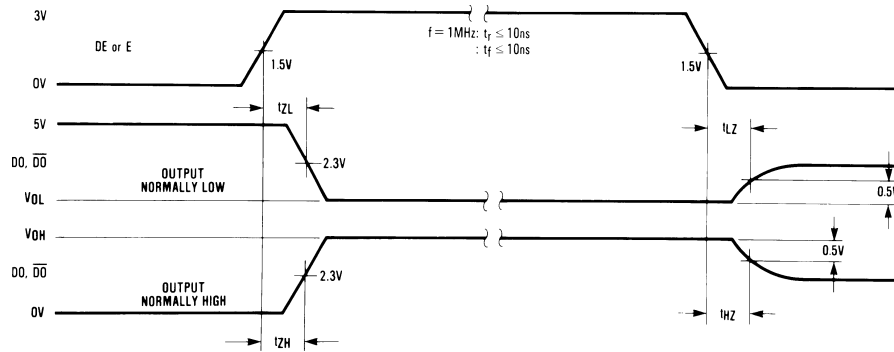

FIGURE 6. Driver Enable/Disable Propagation Delay Timing

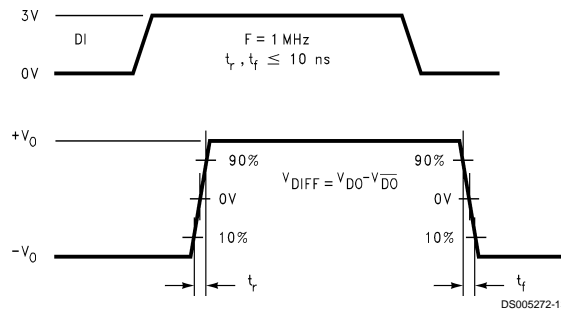

FIGURE 7. Driver Differential Transition Timing

Function Tables

DS3695A/DS3696A Transmitting

Inputs			Line Condition	Outputs		
\overline{RE}	DE	DI		\overline{DO}	DO	\overline{TS}^* (DS3696A Only)
X	1	1	No Fault	0	1	H
X	1	0	No Fault	1	0	H
X	0	X	X	Z	Z	H
X	1	X	Fault	Z	Z	L

DS3695A/DS3696A Receiving

Inputs			Output	
\overline{RE}	DE	$RI-\overline{RI}$	RO	\overline{TS}^* (DS3696A Only)
0	0	$\geq +0.2V$	1	H
0	0	$\leq -0.2V$	0	H
0	0	Inputs Open**	1	H
1	0	X	Z	H

X — Don't care condition

Z — High impedance state

Fault — Improper line conditions causing excessive power dissipation in the driver, such as shorts or bus contention situations

* \overline{TS} is an "open collector" output with an on-chip 10 k Ω pull-up resistor.

** This is a fail safe condition

Typical Application

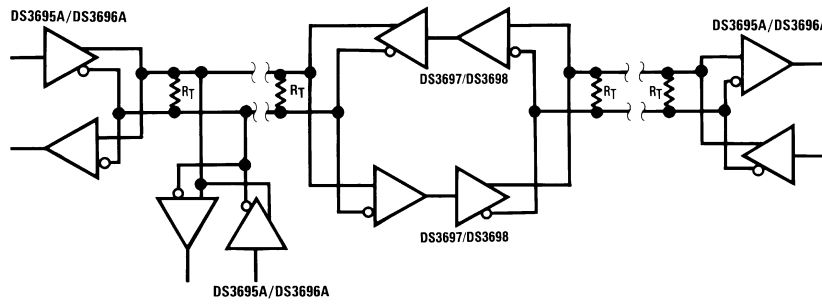

Repeater control logic not shown. See AN-702.

DS005272-18

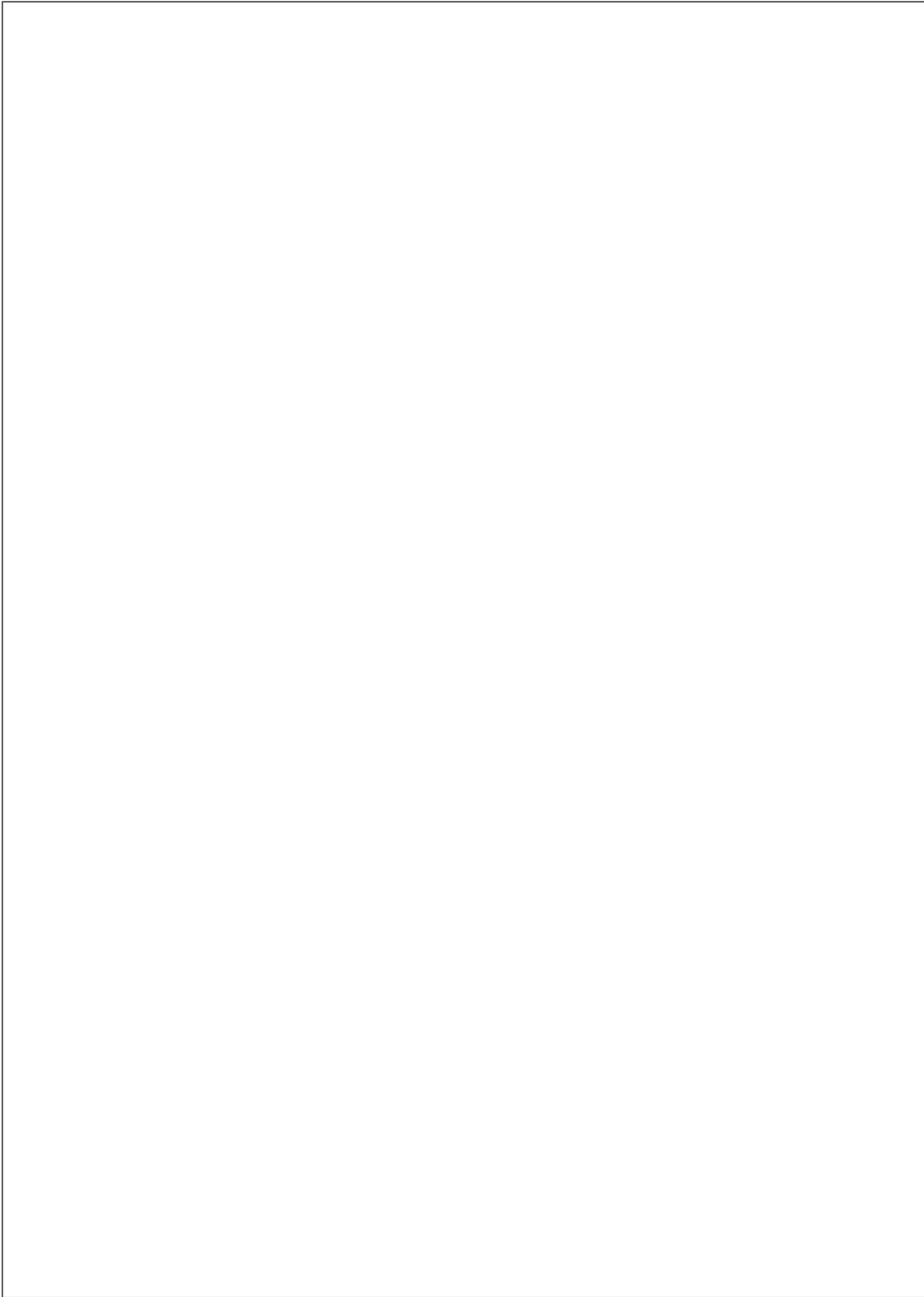

Physical Dimensions inches (millimeters) unless otherwise noted

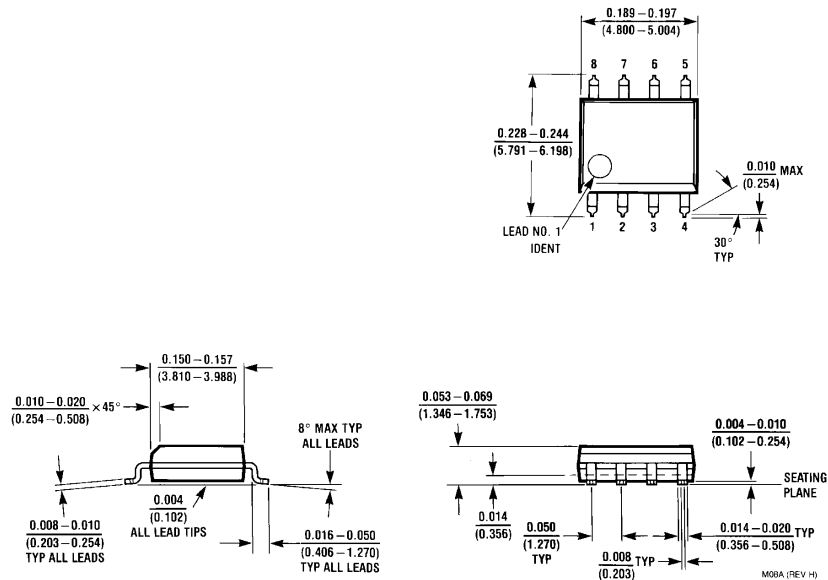

Molded SOIC Package (M)
Order Number DS3695AM, DS3695ATM or DS3696AM
NS Package Number M08A

LIFE SUPPORT POLICY

NATIONAL'S PRODUCTS ARE NOT AUTHORIZED FOR USE AS CRITICAL COMPONENTS IN LIFE SUPPORT DEVICES OR SYSTEMS WITHOUT THE EXPRESS WRITTEN APPROVAL OF THE PRESIDENT OF NATIONAL SEMICONDUCTOR CORPORATION. As used herein:

1. Life support devices or systems are devices or systems which, (a) are intended for surgical implant into the body, or (b) support or sustain life, and whose failure to perform when properly used in accordance with instructions for use provided in the labeling, can be reasonably expected to result in a significant injury to the user.
2. A critical component in any component of a life support device or system whose failure to perform can be reasonably expected to cause the failure of the life support device or system, or to affect its safety or effectiveness.

	National Semiconductor Corporation	National Semiconductor Europe	National Semiconductor Asia Pacific Customer Response Group	National Semiconductor Japan Ltd.
	Americas			
	Tel: 1-800-272-9959	Fax: +49 (0) 1 80-530 85 86	Tel: 65-2544466	Tel: 81-3-5620-6175
	Fax: 1-800-737-7018	Email: europe.support@nsc.com	Fax: 65-2504466	Fax: 81-3-5620-6179
	Email: support@nsc.com		Email: sea.support@nsc.com	
www.national.com				

National does not assume any responsibility for use of any circuitry described, no circuit patent licenses are implied and National reserves the right at any time without notice to change said circuitry and specifications.