

DS1649/DS3649/DS1679/DS3679 Hex TRI-STATE[®] TTL to MOS Drivers

General Description

The DS1649/DS3649 and DS1679/DS3679 are Hex TRI-STATE MOS drivers with outputs designed to drive large capacitive loads up to 500 pF associated with MOS memory systems. PNP input transistors are employed to reduce input currents allowing the large fan-out to these drivers needed in memory systems. The circuit has Schottky-clamped transistor logic for minimum propagation delay, and TRI-STATE outputs for bus operation.

The DS1649/DS3649 has a 15Ω resistor in series with the outputs to dampen transients caused by the fast-switching

output. The DS1679/DS3679 has a direct low impedance output for use with or without an external resistor.

Features

- High speed capabilities
 - Typ 9 ns driving 50 pF
 - Typ 30 ns driving 500 pF
- TRI-STATE outputs for data bussing
- Built-in 15Ω damping resistor (DS1649/DS3649)
- Same pin-out as DM8096 and DM74366

TRI-STATE[®] is a registered trademark of National Semiconductor Corp.

Schematic Diagram

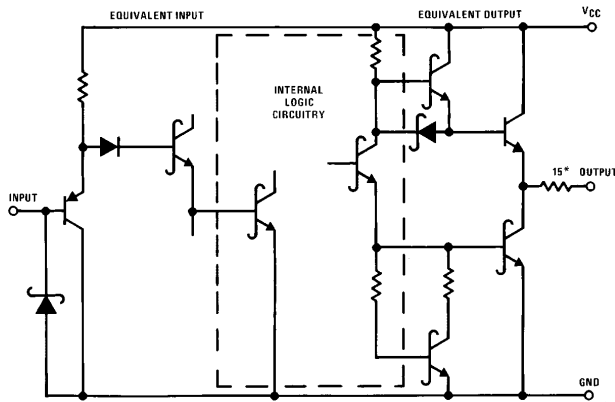

*DS1649/DS3649 only

TL/F/7515-1

Truth Table

Disable Input		Input	Output
DIS 1	DIS 2		
0	0	0	1
0	0	1	0
0	1	X	Hi-Z
1	0	X	Hi-Z
1	1	X	Hi-Z

X = Don't care
Hi-Z = TRI-STATE mode

Connection Diagram

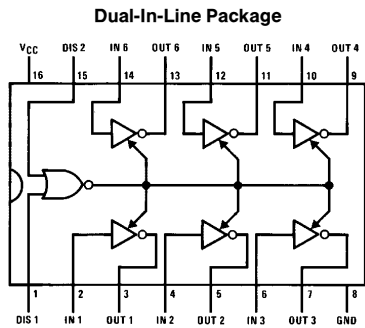

TL/F/7515-2

Top View

Order Number DS1649J, DS3649J,
DS1679J, DS3679J, DS3649N or DS3679N
See NS Package Number J16A or N16A

Typical Application

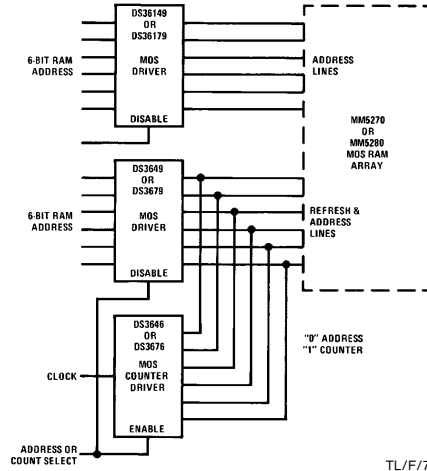

TL/F/7515-3

DS1649/DS3649/DS1679/DS3679 Hex TRI-STATE TTL to MOS Drivers

Absolute Maximum Ratings (Note 1)

If Military/Aerospace specified devices are required, please contact the National Semiconductor Sales Office/Distributors for availability and specifications.

Supply Voltage	7.0V
Logical "1" Input Voltage	7.0V
Logical "0" Input Voltage	-1.5V
Storage Temperature Range	-65°C to +150°C
Maximum Power Dissipation* at 25°C	
Cavity Package	1371 mW
Molded Package	1280 mW
Lead Temperature (Soldering, 10 sec.)	300°C

Operating Conditions

	Min	Max	Units
Supply Voltage (V_{CC})	4.5	5.5	V
Temperature (T_A)			
DS1649, DS1679	-55	+125	°C
DS3649, DS3679	0	+70	°C

*Derate cavity package 9.1 mW/°C above 25°C; derate molded package 10.2 mW/°C above 25°C.

Electrical Characteristics (Note 2 and 3)

Symbol	Parameter	Conditions	Min	Typ	Max	Units	
$V_{IN(1)}$	Logical "1" Input Voltage		2.0			V	
$V_{IN(0)}$	Logical "0" Input Voltage				0.8	V	
$I_{IN(1)}$	Logical "1" Input Current	$V_{CC} = 5.5V, V_{IN} = 5.5V$		0.1	40	μA	
$I_{IN(0)}$	Logical "0" Input Current	$V_{CC} = 5.5V, V_{IN} = 0.5V$		-50	-250	μA	
V_{CLAMP}	Input Clamp Voltage	$V_{CC} = 4.5V, I_{IN} = -18 mA$		-0.75	-1.2	V	
V_{OH}	Logical "1" Output Voltage (No Load)	$V_{CC} = 4.5V, I_{OH} = -10 \mu A$	DS1649/DS1679	2.7	3.6		V
			DS3649/DS3679	2.8	3.6		V
V_{OL}	Logical "0" Output Voltage (No Load)	$V_{CC} = 4.5V, I_{OL} = 10 \mu A$	DS1649/DS1679		0.25	0.4	V
			DS3649/DS3679		0.25	0.35	V
V_{OH}	Logical "1" Output Voltage (With Load)	$V_{CC} = 4.5V, I_{OH} = -1.0 mA$	DS1649	2.4	3.5		V
			DS1679	2.5	3.5		V
			DS3649	2.6	3.5		V
			DS3679	2.7	3.5		V
V_{OL}	Logical "0" Output Voltage (With Load)	$V_{CC} = 4.5V, I_{OL} = 20 mA$	DS1649		0.6	1.1	V
			DS1679		0.4	0.5	V
			DS3649		0.6	1.0	V
			DS3679		0.4	0.5	V
I_{1D}	Logical "1" Drive Current	$V_{CC} = 4.5V, V_{OUT} = 0V$ (Note 4)		-250		mA	
I_{0D}	Logical "0" Drive Current	$V_{CC} = 4.5V, V_{OUT} = 4.5V$ (Note 4)		150		mA	
Hi-Z	TRI-STATE Output Current	$V_{OUT} = 0.4V$ to $2.4V$, DIS1 or DIS2 = 2.0V	-40		40	μA	
I_{CC}	Power Supply Current	$V_{CC} = 5.5V$	One DIS Input = 3.0V All Other Inputs = X		42	75	mA
			All Inputs = 0V		11	20	mA

Switching Characteristics ($V_{CC} = 5V, T_A = 25^\circ C$) (Note 4)

Symbol	Parameter	Conditions	Min	Typ	Max	Units
$t_{S\pm}$	Storage Delay Negative Edge	(Figure 1) $C_L = 50 \text{ pF}$		4.5	7	ns
		$C_L = 500 \text{ pF}$		7.5	12	ns
$t_{S\pm}$	Storage Delay Positive Edge	(Figure 1) $C_L = 50 \text{ pF}$		5	8	ns
		$C_L = 500 \text{ pF}$		8	13	ns
t_F	Fall Time	(Figure 1) $C_L = 50 \text{ pF}$		5	8	ns
		$C_L = 500 \text{ pF}$		22	35	ns
t_R	Rise Time	(Figure 1) $C_L = 50 \text{ pF}$		6	9	ns
		$C_L = 500 \text{ pF}$		21	35	ns
t_{ZL}	Delay from Disable Input to Logical "0" Level (from High Impedance State)	$C_L = 50 \text{ pF}$ $R_L = 2 \text{ k}\Omega$ to V_{CC} (Figure 2)		10	15	ns
t_{ZH}	Delay from Disable Input to Logical "1" Level (from High Impedance State)	$C_L = 50 \text{ pF}$ $R_L = 2 \text{ k}\Omega$ to GND (Figure 2)		8	15	ns
t_{LZ}	Delay from Disable Input to High Impedance State (from Logical "0" Level)	$C_L = 50 \text{ pF}$ $R_L = 400\Omega$ to V_{CC} (Figure 3)		15	25	ns
t_{HZ}	Delay from Disable Input to High Impedance State (from Logical "1" Level)	$C_L = 50 \text{ pF}$ $R_L = 400\Omega$ to GND (Figure 3)		10	25	ns

Note 1: "Absolute Maximum Ratings" are those values beyond which the safety of the device cannot be guaranteed. Except for "Operating Temperature Range" they are not meant to imply that the devices should be operated at these limits. The table of "Electrical Characteristics" provides conditions for actual device operation.

Note 2: Unless otherwise specified min/max limits apply across the $-55^\circ C$ to $+125^\circ C$ temperature range for the DS1649 and DS1679 and across the $0^\circ C$ to $+70^\circ C$ range for the DS3649 and DS3679. All typical values are for $T_A = 25^\circ C$ and $V_{CC} = 5V$.

Note 3: All currents into device pins shown as positive, out of device pins as negative, all voltages referenced to ground unless otherwise noted. All values shown as max or min on absolute value basis.

Note 4: When measuring output drive current and switching response for the DS1679 and DS3679 a 15Ω resistor should be placed in series with each output. This resistor is internal to the DS1649/DS3649 and need not be added.

AC Test Circuits and Switching Time Waveforms

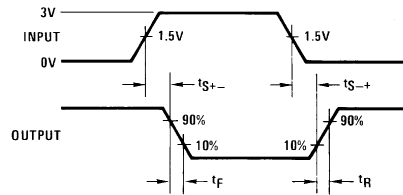
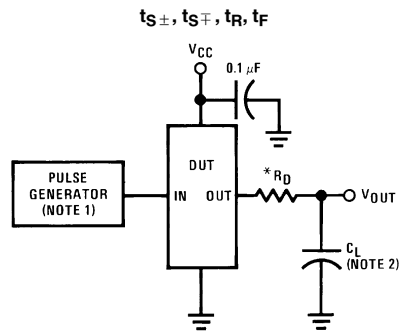

TL/F/7515-4

FIGURE 1

TL/F/7515-5

AC Test Circuits and Switching Time Waveforms (Continued)

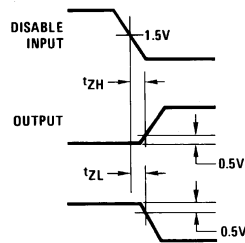
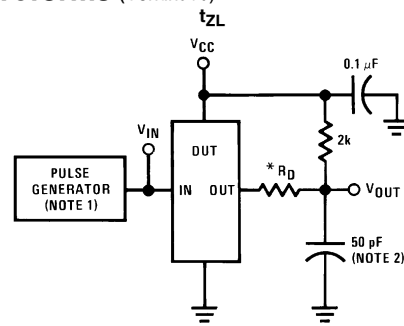
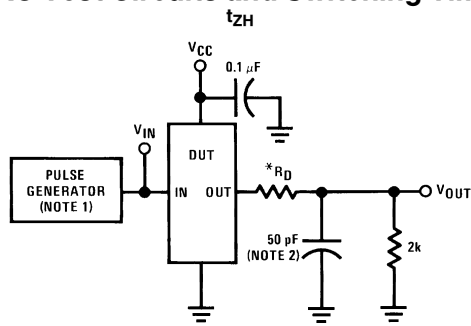

FIGURE 2

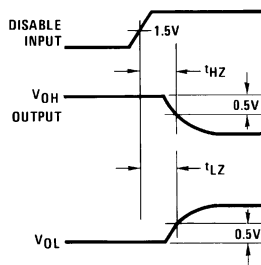
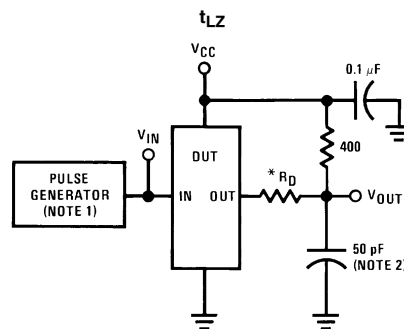
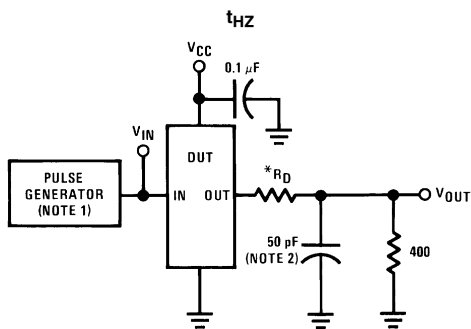

FIGURE 3

*Internal on DS1649 and DS3649

Note 1: The pulse generator has the following characteristics: $Z_{OUT} = 50\Omega$ and $PRR \leq 1$ MHz. Rise and fall times between 10% and 90% points ≤ 5 ns.

Note 2: C_L includes probe and jig capacitance.

Physical Dimensions inches (millimeters)

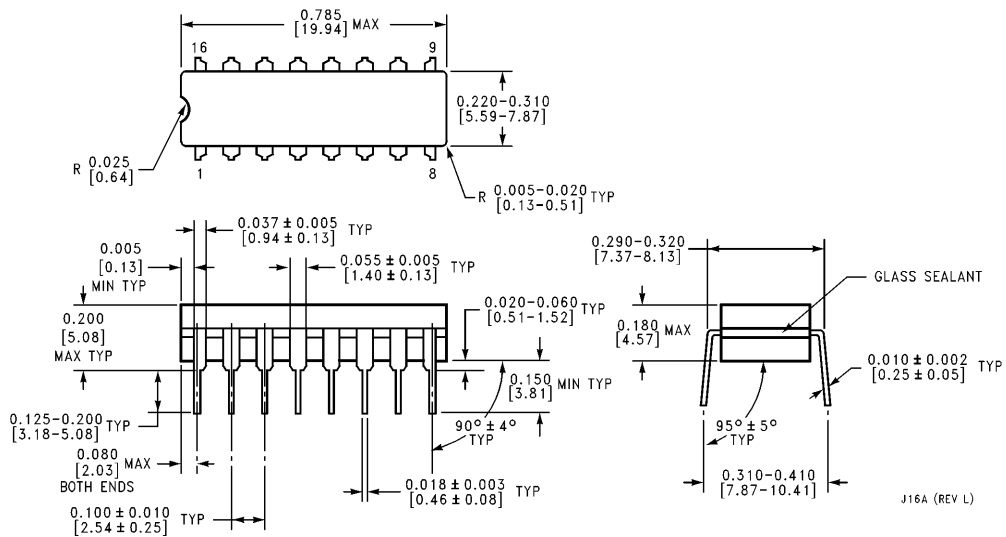

Ceramic Dual-In-Line Package (J)
Order Number DS1649J, DS3649J,
DS1679J or DS3679J
NS Package Number J16A

J16A (REV L)

Physical Dimensions inches (millimeters) (Continued)

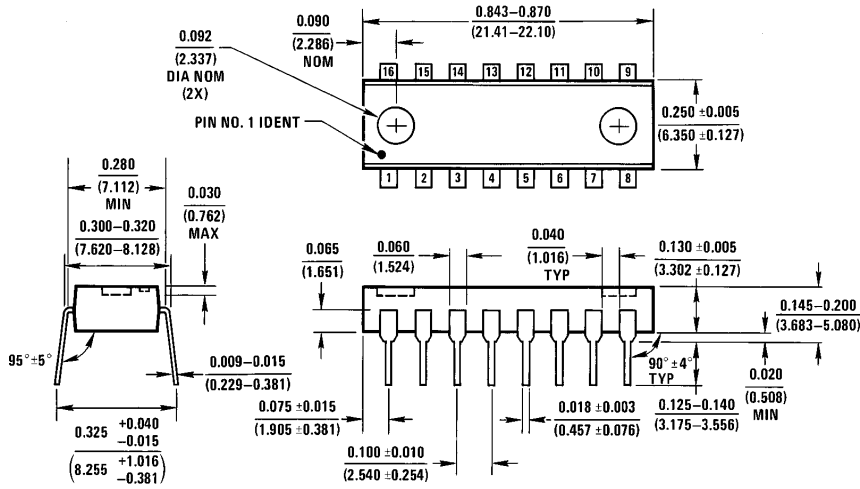

Molded Dual-In-Line Package (N)
Order Number DS3649N or DS3679N
NS Package Number N16A

N16A (REV E)

LIFE SUPPORT POLICY

NATIONAL'S PRODUCTS ARE NOT AUTHORIZED FOR USE AS CRITICAL COMPONENTS IN LIFE SUPPORT DEVICES OR SYSTEMS WITHOUT THE EXPRESS WRITTEN APPROVAL OF THE PRESIDENT OF NATIONAL SEMICONDUCTOR CORPORATION. As used herein:

1. Life support devices or systems are devices or systems which, (a) are intended for surgical implant into the body, or (b) support or sustain life, and whose failure to perform, when properly used in accordance with instructions for use provided in the labeling, can be reasonably expected to result in a significant injury to the user.
2. A critical component is any component of a life support device or system whose failure to perform can be reasonably expected to cause the failure of the life support device or system, or to affect its safety or effectiveness.



National Semiconductor Corporation
 1111 West Bardin Road
 Arlington, TX 76017
 Tel: 1(800) 272-9959
 Fax: 1(800) 737-7018

National Semiconductor Europe
 Fax: (+49) 0-180-530 85 86
 Email: cnjwge@tevm2.nsc.com
 Deutsch Tel: (+49) 0-180-530 85 85
 English Tel: (+49) 0-180-532 78 32
 Français Tel: (+49) 0-180-532 93 58
 Italiano Tel: (+49) 0-180-534 16 80

National Semiconductor Hong Kong Ltd.
 19th Floor, Straight Block,
 Ocean Centre, 5 Canton Rd.
 Tsimshatsui, Kowloon
 Hong Kong
 Tel: (852) 2737-1600
 Fax: (852) 2736-9960

National Semiconductor Japan Ltd.
 Tel: 81-043-299-2309
 Fax: 81-043-299-2408

National does not assume any responsibility for use of any circuitry described, no circuit patent licenses are implied and National reserves the right at any time without notice to change said circuitry and specifications.