

## DS34C86T Quad CMOS Differential Line Receiver

Check for Samples: [DS34C86T](#)

### FEATURES

- **CMOS Design for Low Power**
- **$\pm 0.2\text{V}$  Sensitivity Over the Input Common Mode Voltage Range**
- **Typical Propagation Delays: 19 ns**
- **Typical Input Hysteresis: 60 mV**
- **Inputs Won't Load Line when  $V_{CC} = 0\text{V}$**
- **Meets the Requirements of EIA Standard RS-422**
- **TRI-STATE Outputs for System Bus Compatibility**
- **Available in Surface Mount**
- **Open Input Failsafe Feature, Output High for Open Input**

### DESCRIPTION

The DS34C86T is a quad differential line receiver designed to meet the RS-422, RS-423, and Federal Standards 1020 and 1030 for balanced and unbalanced digital data transmission, while retaining the low power characteristics of CMOS.

The DS34C86T has an input sensitivity of 200 mV over the common mode input voltage range of  $\pm 7\text{V}$ . Hysteresis is provided to improve noise margin and discourage output instability for slowly changing input waveforms.

The DS34C86T features internal pull-up and pull-down resistors which prevent output oscillation on unused channels.

Separate enable pins allow independent control of receiver pairs. The TRI-STATE outputs have 6 mA source and sink capability. The DS34C86T is pin compatible with the DS3486.

### Logic Diagram

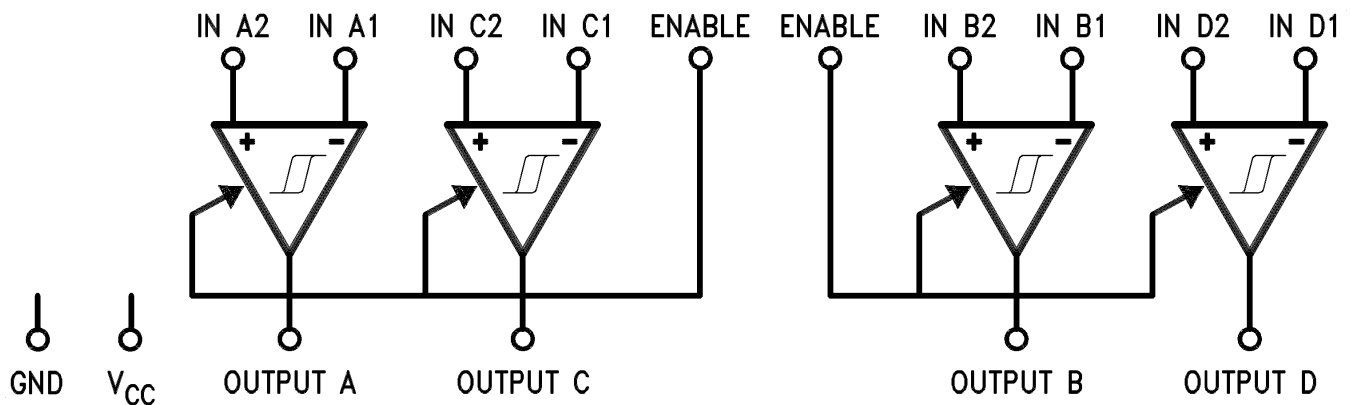

Please be aware that an important notice concerning availability, standard warranty, and use in critical applications of Texas Instruments semiconductor products and disclaimers thereto appears at the end of this data sheet.

All trademarks are the property of their respective owners.

## Connection Diagram

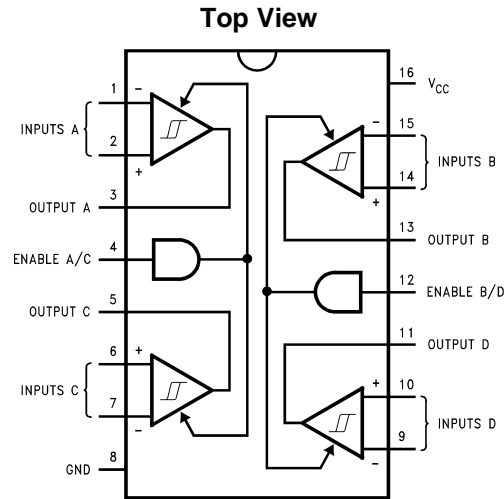

**Figure 1. PDIP Package**  
See Package Numbers D0016A or NFG0016E

### Truth Table<sup>(1)</sup>

Enable	Input	Output
L	X	Z
H	$V_{ID} \geq V_{TH}$ (Max)	H
H	$V_{ID} \leq V_{TH}$ (Min)	L
H	Open*	H

(1) Open, not terminated. Z = TRI-STATE



These devices have limited built-in ESD protection. The leads should be shorted together or the device placed in conductive foam during storage or handling to prevent electrostatic damage to the MOS gates.

### Absolute Maximum Ratings<sup>(1)(2)(3)(4)</sup>

Supply Voltage ( $V_{CC}$ )	7V
Input Common Mode Range ( $V_{CM}$ )	$\pm 14V$
Differential Input Voltage ( $V_{DIFF}$ )	$\pm 14V$
Enable Input Voltage ( $V_{IN}$ )	7V
Storage Temperature Range ( $T_{STG}$ )	$-65^{\circ}C$ to $+150^{\circ}C$
Lead Temperature (Soldering 4 sec)	$260^{\circ}C$
Maximum Power Dissipation at $25^{\circ}C$ <sup>(5)</sup>	
PDIP Package	1645 mW
SOIC Package	1190 mW
Current Per Output	$\pm 25$ mA
This device does not meet 2000V ESD rating <sup>(1)</sup>	

- (1) ESD Rating; HBM (1.5k $\Omega$ , 100 pF) Inputs  $\geq 2000V$  All other pins  $\geq 1000V$  EIAJ (0 $\Omega$ , 200 pF)  $\geq 350V$
- (2) Unless otherwise specified, all voltages are referenced to ground.
- (3) Absolute Maximum Ratings are values beyond which the safety of the device cannot be specified. They are not meant to imply that the device should be operated at these limits. The "Electrical Characteristics" provide conditions for actual device operation.
- (4) If Military/Aerospace specified devices are required, please contact the TI Sales Office/Distributors for availability and specifications.
- (5) Ratings apply to ambient temperature at  $25^{\circ}C$ . Above this temperature derate NFG0016E Package 13.16 mW/ $^{\circ}C$ , and D0016A Package 9.52 mW/ $^{\circ}C$ .

## Operating Conditions

	Min	Max	Unit
Supply Voltage ( $V_{CC}$ )	4.50	5.50	V
Operating Temperature Range ( $T_A$ )	-40	+85	°C
Enable Input Rise or Fall Times		500	ns

## DC Electrical Characteristics<sup>(1)</sup>

 $V_{CC} = 5V \pm 10\%$  (unless otherwise specified)

Parameter		Test Conditions	Min	Typ	Max	Units
$V_{TH}$	Minimum Differential Input Voltage	$V_{OUT} = V_{OH}$ or $V_{OL}$ $-7V < V_{CM} < +7V$	-200	35	+200	mV
$R_{IN}$	Input Resistance	$V_{IN} = -7V, +7V$ (Other Input = GND)	5.0	6.8	10	k $\Omega$
$I_{IN}$	Input Current (Under Test)	$V_{IN} = +10V$ , Other Input = GND		+1.1	+1.5	mA
		$V_{IN} = -10V$ , Other Input = GND		-2.0	-2.5	mA
$V_{OH}$	Minimum High Level Output Voltage	$V_{CC} = \text{Min.}$ , $V_{(DIFF)} = +1V$ $I_{OUT} = -6.0 \text{ mA}$	3.8	4.2		V
$V_{OL}$	Maximum Low Level Output Voltage	$V_{CC} = \text{Max.}$ , $V_{(DIFF)} = -1V$ $I_{OUT} = 6.0 \text{ mA}$		0.2	0.3	V
$V_{IH}$	Minimum Enable High Input Level Voltage		2.0			V
$V_{IL}$	Maximum Enable Low Input Level Voltage				0.8	V
$I_{OZ}$	Maximum TRI-STATE Output Leakage Current	$V_{OUT} = V_{CC}$ or GND, TRI-STATE Control = $V_{IL}$		$\pm 0.5$	$\pm 5.0$	$\mu\text{A}$
$I_I$	Maximum Enable Input Current	$V_{IN} = V_{CC}$ or GND			$\pm 1.0$	$\mu\text{A}$
$I_{CC}$	Quiescent Power Supply Current	$V_{CC} = \text{Max.}$ , $V_{(DIFF)} = +1V$		16	23	mA
$V_{HYST}$	Input Hysteresis	$V_{CM} = 0V$		60		mV

(1) Unless otherwise specified, Min/Max limits apply across the operating temperature range. All typicals are given for  $V_{CC} = 5V$  and  $T_A = 25^\circ\text{C}$ .

## AC Electrical Characteristics<sup>(1)</sup>

 $V_{CC} = 5V \pm 10\%$  (unless otherwise specified) (Figure 2, Figure 3, Figure 4)

Parameter		Test Conditions	Min	Typ	Max	Units
$t_{PLH}$ , $t_{PHL}$	Propagation Delay Input to Output	$C_L = 50 \text{ pF}$ $V_{DIFF} = 2.5V$ $V_{CM} = 0V$		19	30	ns
$t_{RISE}$ , $t_{FALL}$	Output Rise and Fall Times	$C_L = 50 \text{ pF}$ $V_{DIFF} = 2.5V$ $V_{CM} = 0V$		4	9	ns
$t_{PLZ}$ , $t_{PHZ}$	Propagation Delay ENABLE to Output	$C_L = 50 \text{ pF}$ $R_L = 1000\Omega$ $V_{DIFF} = 2.5V$		13	18	ns
$t_{PZL}$ , $t_{PZH}$	Propagation Delay ENABLE to Output	$C_L = 50 \text{ pF}$ $R_L = 1000\Omega$ $V_{DIFF} = 2.5V$		13	21	ns

(1) Unless otherwise specified, Min/Max limits apply across the operating temperature range. All typicals are given for  $V_{CC} = 5V$  and  $T_A = 25^\circ\text{C}$ .

### Comparison Table of Switching Characteristics into “LS-Type” Load<sup>(1)</sup>

V<sub>CC</sub> = 5V, T<sub>A</sub> = 25°C (Figure 5, Figure 6)

Parameter		DS34C86		DS3486		Units
		Typ	Max	Typ	Max	
t <sub>PHL(D)</sub>	Propagation Delay Time Output High to Low	17		19		ns
t <sub>PLH(D)</sub>	Propagation Delay Time Output Low to High	19		19		ns
t <sub>PLZ</sub>	Output Low to TRI-STATE	13		23		ns
t <sub>PHZ</sub>	Output High to TRI-STATE	12		25		ns
t <sub>PZH</sub>	Output TRI-STATE to High	13		18		ns
t <sub>PZL</sub>	Output TRI-STATE to Low	13		20		ns

(1) This table is provided for comparison purposes only. The values in this table for the DS34C86 reflect the performance of the device but are not tested or specified.

### TEST AND SWITCHING WAVEFORMS

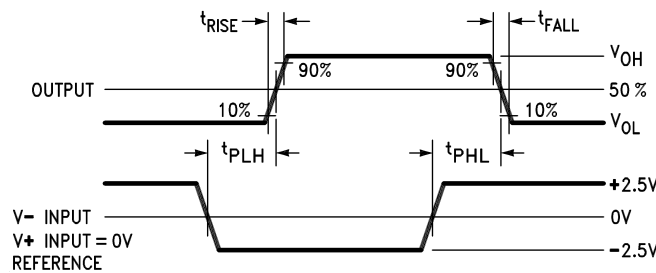
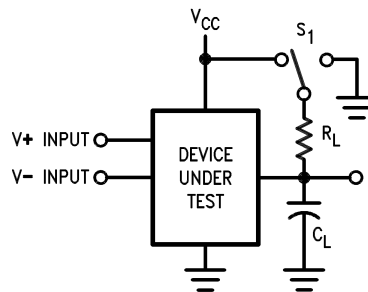

Figure 2. Propagation Delays



C<sub>L</sub> Includes load and test jig capacitance.  
 S1 = V<sub>CC</sub> for t<sub>PZL</sub>, and t<sub>PLZ</sub> measurements.  
 S1 = GND for t<sub>PZH</sub>, and t<sub>PHZ</sub> measurements.

Figure 3. Test Circuit for TRI-STATE Output Tests

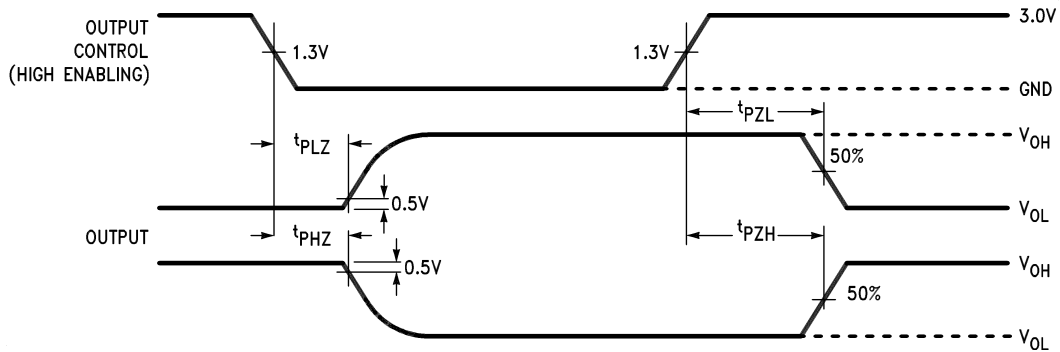
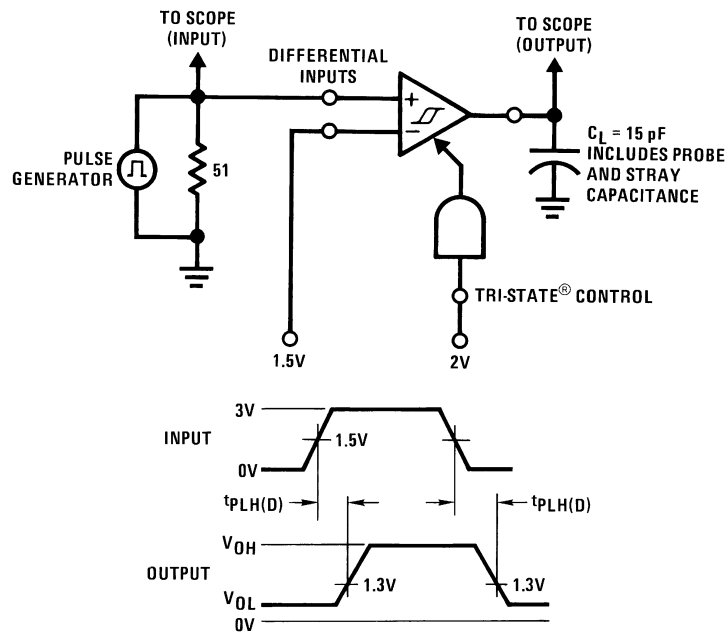

Figure 4. TRI-STATE Output Enable and Disable Waveforms

AC Test Circuits and Switching Time Waveforms



Input Pulse Characteristics:  
 $t_{TLH} = t_{THL} = 6 \text{ ns}$  (10% to 90%)  
 PRR = 1 MHz, 50% duty cycle

Figure 5. Propagation Delay Differential Input to Output for “LS-Type” Load

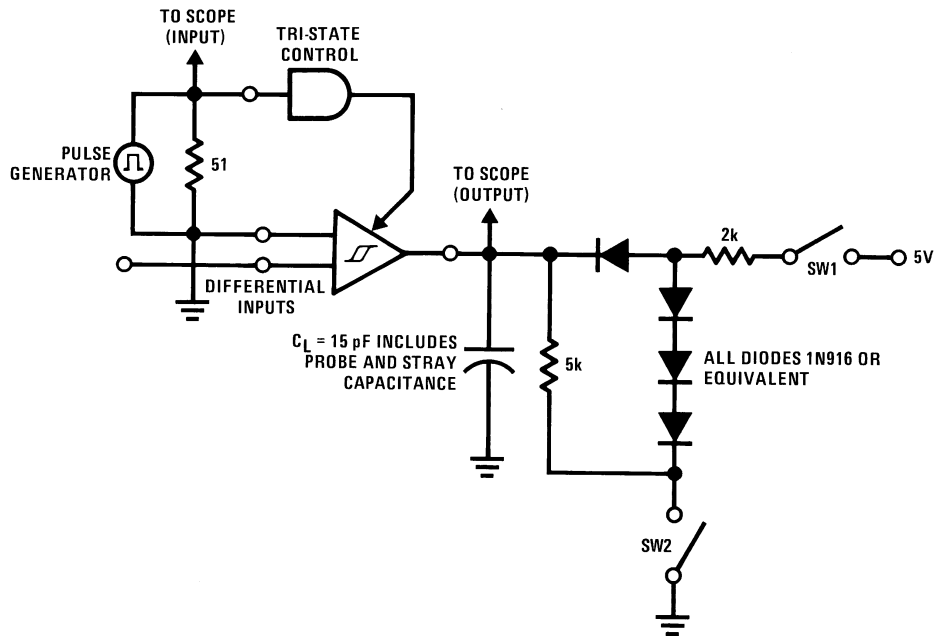

1.5V for  $t_{pHZ}$  and  $t_{pLZ}$   
 -1.5V for  $t_{pLZ}$  and  $t_{pZL}$   
 Input Pulse Characteristics:  
 $t_{TLH} = t_{THL} = 6$  ns (10% to 90%)  
 PRR = 1 MHz, 50% duty cycle

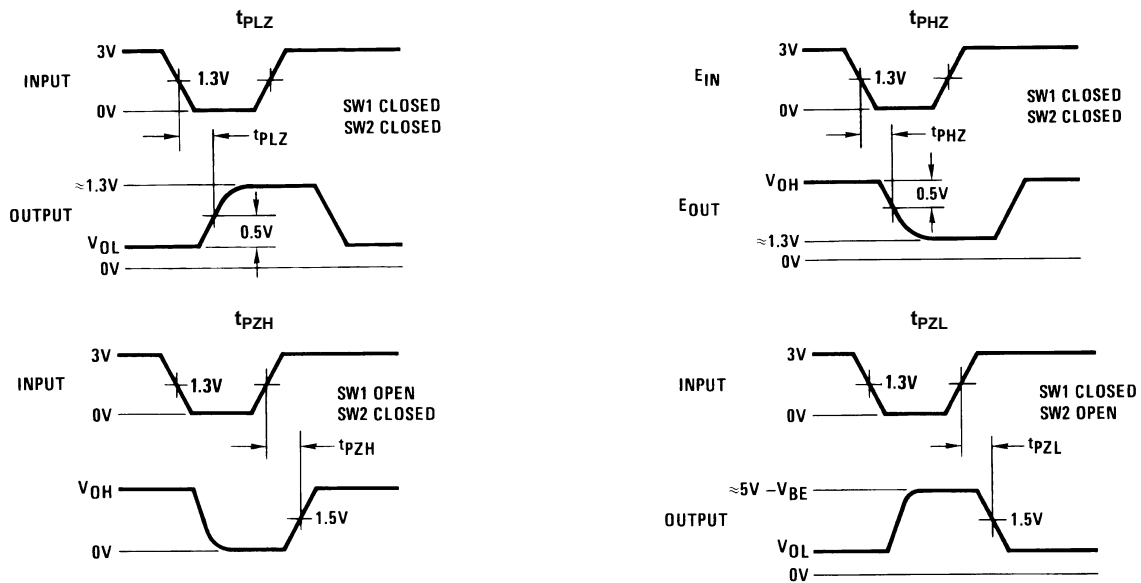

Figure 6. Propagation Delay TRI-STATE Control Unit to Output for “LS-Type” Load

---

**REVISION HISTORY**

<b>Changes from Revision B (April 2013) to Revision C</b>	<b>Page</b>
<hr/> <ul style="list-style-type: none"><li>• Changed layout of National Data Sheet to TI format .....</li></ul>	<hr/> <b>6</b>

## PACKAGING INFORMATION

Orderable Device	Status (1)	Package Type	Package Drawing	Pins	Package Qty	Eco Plan (2)	Lead/Ball Finish	MSL Peak Temp (3)	Op Temp (°C)	Top-Side Markings (4)	Samples
DS34C86TM	ACTIVE	SOIC	D	16	48	TBD	Call TI	Call TI	-40 to 85	DS34C86TM	<a href="#">Samples</a>
DS34C86TM/NOPB	ACTIVE	SOIC	D	16	48	Green (RoHS & no Sb/Br)	CU SN	Level-1-260C-UNLIM	-40 to 85	DS34C86TM	<a href="#">Samples</a>
DS34C86TMX	ACTIVE	SOIC	D	16	2500	TBD	Call TI	Call TI	-40 to 85	DS34C86TM	<a href="#">Samples</a>
DS34C86TMX/NOPB	ACTIVE	SOIC	D	16	2500	Green (RoHS & no Sb/Br)	CU SN	Level-1-260C-UNLIM	-40 to 85	DS34C86TM	<a href="#">Samples</a>

(1) The marketing status values are defined as follows:

**ACTIVE:** Product device recommended for new designs.

**LIFEBUY:** TI has announced that the device will be discontinued, and a lifetime-buy period is in effect.

**NRND:** Not recommended for new designs. Device is in production to support existing customers, but TI does not recommend using this part in a new design.

**PREVIEW:** Device has been announced but is not in production. Samples may or may not be available.

**OBSOLETE:** TI has discontinued the production of the device.

(2) Eco Plan - The planned eco-friendly classification: Pb-Free (RoHS), Pb-Free (RoHS Exempt), or Green (RoHS & no Sb/Br) - please check <http://www.ti.com/productcontent> for the latest availability information and additional product content details.

**TBD:** The Pb-Free/Green conversion plan has not been defined.

**Pb-Free (RoHS):** TI's terms "Lead-Free" or "Pb-Free" mean semiconductor products that are compatible with the current RoHS requirements for all 6 substances, including the requirement that lead not exceed 0.1% by weight in homogeneous materials. Where designed to be soldered at high temperatures, TI Pb-Free products are suitable for use in specified lead-free processes.

**Pb-Free (RoHS Exempt):** This component has a RoHS exemption for either 1) lead-based flip-chip solder bumps used between the die and package, or 2) lead-based die adhesive used between the die and leadframe. The component is otherwise considered Pb-Free (RoHS compatible) as defined above.

**Green (RoHS & no Sb/Br):** TI defines "Green" to mean Pb-Free (RoHS compatible), and free of Bromine (Br) and Antimony (Sb) based flame retardants (Br or Sb do not exceed 0.1% by weight in homogeneous material)

(3) MSL, Peak Temp. -- The Moisture Sensitivity Level rating according to the JEDEC industry standard classifications, and peak solder temperature.

(4) Multiple Top-Side Markings will be inside parentheses. Only one Top-Side Marking contained in parentheses and separated by a "~" will appear on a device. If a line is indented then it is a continuation of the previous line and the two combined represent the entire Top-Side Marking for that device.

**Important Information and Disclaimer:** The information provided on this page represents TI's knowledge and belief as of the date that it is provided. TI bases its knowledge and belief on information provided by third parties, and makes no representation or warranty as to the accuracy of such information. Efforts are underway to better integrate information from third parties. TI has taken and continues to take reasonable steps to provide representative and accurate information but may not have conducted destructive testing or chemical analysis on incoming materials and chemicals. TI and TI suppliers consider certain information to be proprietary, and thus CAS numbers and other limited information may not be available for release.

In no event shall TI's liability arising out of such information exceed the total purchase price of the TI part(s) at issue in this document sold by TI to Customer on an annual basis.



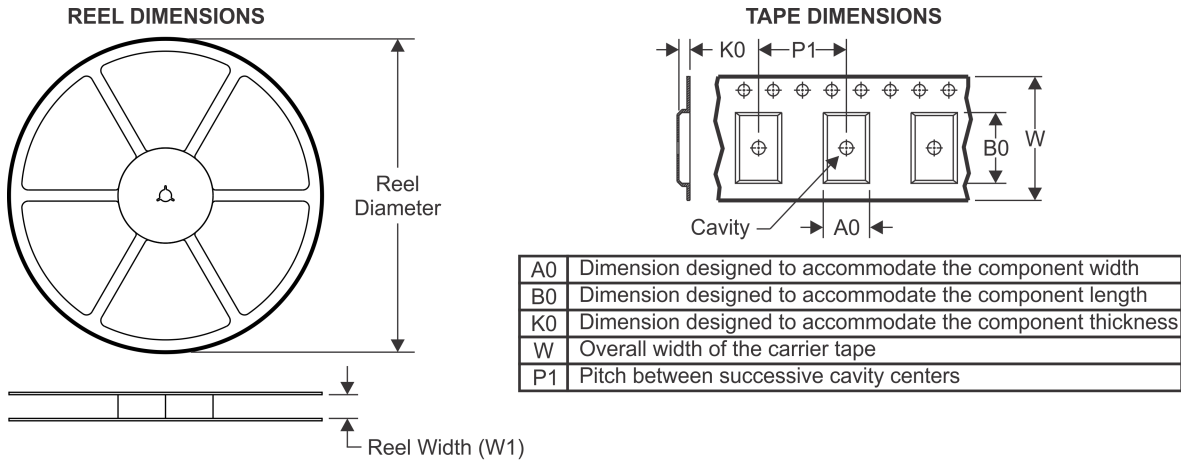

**TAPE AND REEL INFORMATION**

**QUADRANT ASSIGNMENTS FOR PIN 1 ORIENTATION IN TAPE**

\*All dimensions are nominal

Device	Package Type	Package Drawing	Pins	SPQ	Reel Diameter (mm)	Reel Width W1 (mm)	A0 (mm)	B0 (mm)	K0 (mm)	P1 (mm)	W (mm)	Pin1 Quadrant
DS34C86TMX	SOIC	D	16	2500	330.0	16.4	6.5	10.3	2.3	8.0	16.0	Q1
DS34C86TMX/NOPB	SOIC	D	16	2500	330.0	16.4	6.5	10.3	2.3	8.0	16.0	Q1

**TAPE AND REEL BOX DIMENSIONS**

\*All dimensions are nominal

Device	Package Type	Package Drawing	Pins	SPQ	Length (mm)	Width (mm)	Height (mm)
DS34C86TMX	SOIC	D	16	2500	367.0	367.0	35.0
DS34C86TMX/NOPB	SOIC	D	16	2500	367.0	367.0	35.0

D (R-PDSO-G16)

PLASTIC SMALL OUTLINE



- NOTES:
- A. All linear dimensions are in inches (millimeters).
  - B. This drawing is subject to change without notice.
  - C. Body length does not include mold flash, protrusions, or gate burrs. Mold flash, protrusions, or gate burrs shall not exceed 0.006 (0,15) each side.
  - D. Body width does not include interlead flash. Interlead flash shall not exceed 0.017 (0,43) each side.
  - E. Reference JEDEC MS-012 variation AC.

## IMPORTANT NOTICE

Texas Instruments Incorporated and its subsidiaries (TI) reserve the right to make corrections, enhancements, improvements and other changes to its semiconductor products and services per JESD46, latest issue, and to discontinue any product or service per JESD48, latest issue. Buyers should obtain the latest relevant information before placing orders and should verify that such information is current and complete. All semiconductor products (also referred to herein as "components") are sold subject to TI's terms and conditions of sale supplied at the time of order acknowledgment.

TI warrants performance of its components to the specifications applicable at the time of sale, in accordance with the warranty in TI's terms and conditions of sale of semiconductor products. Testing and other quality control techniques are used to the extent TI deems necessary to support this warranty. Except where mandated by applicable law, testing of all parameters of each component is not necessarily performed.

TI assumes no liability for applications assistance or the design of Buyers' products. Buyers are responsible for their products and applications using TI components. To minimize the risks associated with Buyers' products and applications, Buyers should provide adequate design and operating safeguards.

TI does not warrant or represent that any license, either express or implied, is granted under any patent right, copyright, mask work right, or other intellectual property right relating to any combination, machine, or process in which TI components or services are used. Information published by TI regarding third-party products or services does not constitute a license to use such products or services or a warranty or endorsement thereof. Use of such information may require a license from a third party under the patents or other intellectual property of the third party, or a license from TI under the patents or other intellectual property of TI.

Reproduction of significant portions of TI information in TI data books or data sheets is permissible only if reproduction is without alteration and is accompanied by all associated warranties, conditions, limitations, and notices. TI is not responsible or liable for such altered documentation. Information of third parties may be subject to additional restrictions.

Resale of TI components or services with statements different from or beyond the parameters stated by TI for that component or service voids all express and any implied warranties for the associated TI component or service and is an unfair and deceptive business practice. TI is not responsible or liable for any such statements.

Buyer acknowledges and agrees that it is solely responsible for compliance with all legal, regulatory and safety-related requirements concerning its products, and any use of TI components in its applications, notwithstanding any applications-related information or support that may be provided by TI. Buyer represents and agrees that it has all the necessary expertise to create and implement safeguards which anticipate dangerous consequences of failures, monitor failures and their consequences, lessen the likelihood of failures that might cause harm and take appropriate remedial actions. Buyer will fully indemnify TI and its representatives against any damages arising out of the use of any TI components in safety-critical applications.

In some cases, TI components may be promoted specifically to facilitate safety-related applications. With such components, TI's goal is to help enable customers to design and create their own end-product solutions that meet applicable functional safety standards and requirements. Nonetheless, such components are subject to these terms.

No TI components are authorized for use in FDA Class III (or similar life-critical medical equipment) unless authorized officers of the parties have executed a special agreement specifically governing such use.

Only those TI components which TI has specifically designated as military grade or "enhanced plastic" are designed and intended for use in military/aerospace applications or environments. Buyer acknowledges and agrees that any military or aerospace use of TI components which have **not** been so designated is solely at the Buyer's risk, and that Buyer is solely responsible for compliance with all legal and regulatory requirements in connection with such use.

TI has specifically designated certain components as meeting ISO/TS16949 requirements, mainly for automotive use. In any case of use of non-designated products, TI will not be responsible for any failure to meet ISO/TS16949.

### Products

Audio	<a href="http://www.ti.com/audio">www.ti.com/audio</a>
Amplifiers	<a href="http://amplifier.ti.com">amplifier.ti.com</a>
Data Converters	<a href="http://dataconverter.ti.com">dataconverter.ti.com</a>
DLP® Products	<a href="http://www.dlp.com">www.dlp.com</a>
DSP	<a href="http://dsp.ti.com">dsp.ti.com</a>
Clocks and Timers	<a href="http://www.ti.com/clocks">www.ti.com/clocks</a>
Interface	<a href="http://interface.ti.com">interface.ti.com</a>
Logic	<a href="http://logic.ti.com">logic.ti.com</a>
Power Mgmt	<a href="http://power.ti.com">power.ti.com</a>
Microcontrollers	<a href="http://microcontroller.ti.com">microcontroller.ti.com</a>
RFID	<a href="http://www.ti-rfid.com">www.ti-rfid.com</a>
OMAP Applications Processors	<a href="http://www.ti.com/omap">www.ti.com/omap</a>
Wireless Connectivity	<a href="http://www.ti.com/wirelessconnectivity">www.ti.com/wirelessconnectivity</a>

### Applications

Automotive and Transportation	<a href="http://www.ti.com/automotive">www.ti.com/automotive</a>
Communications and Telecom	<a href="http://www.ti.com/communications">www.ti.com/communications</a>
Computers and Peripherals	<a href="http://www.ti.com/computers">www.ti.com/computers</a>
Consumer Electronics	<a href="http://www.ti.com/consumer-apps">www.ti.com/consumer-apps</a>
Energy and Lighting	<a href="http://www.ti.com/energy">www.ti.com/energy</a>
Industrial	<a href="http://www.ti.com/industrial">www.ti.com/industrial</a>
Medical	<a href="http://www.ti.com/medical">www.ti.com/medical</a>
Security	<a href="http://www.ti.com/security">www.ti.com/security</a>
Space, Avionics and Defense	<a href="http://www.ti.com/space-avionics-defense">www.ti.com/space-avionics-defense</a>
Video and Imaging	<a href="http://www.ti.com/video">www.ti.com/video</a>

### TI E2E Community

[e2e.ti.com](http://e2e.ti.com)