

## DS26LS31C/DS26LS31M Quad High Speed Differential Line Driver

 Check for Samples: [DS26LS31C](#), [DS26LS31M](#)

### FEATURES

- Output Skew—2.0 ns Typical
- Input to output delay—10 ns Typical
- Operation from Single 5V Supply
- Outputs Won't Load Line when  $V_{CC} = 0V$
- Four Line Drivers in One Package for Maximum Package Density
- Output Short-Circuit Protection
- Complementary Outputs
- Meets the Requirements of EIA Standard RS-422
- Pin Compatible with AM26LS31
- Available in Military and Commercial Temperature Range

### DESCRIPTION

The DS26LS31 is a quad differential line driver designed for digital data transmission over balanced lines. The DS26LS31 meets all the requirements of EIA Standard RS-422 and Federal Standard 1020. It is designed to provide unipolar differential drive to twisted-pair or parallel-wire transmission lines.

The circuit provides an enable and disable function common to all four drivers. The DS26LS31 features TRI-STATE outputs and logically ANDed complementary outputs. The inputs are all LS compatible and are all one unit load.

### Logic and Connection Diagrams

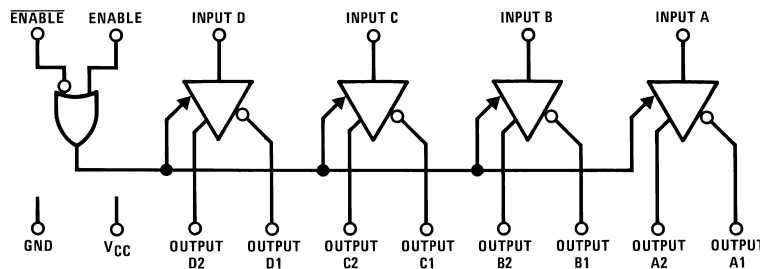

Top View

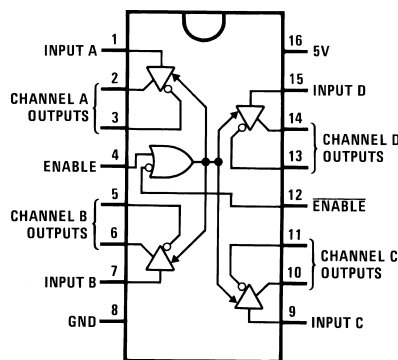

For Complete Military Product Specifications, refer to the appropriate SMD or MDS.

**Figure 1. PDIP Package**  
 See Package D0016A or NFG0016E  
 See Package Numbers NAJ0020A, NFE0016A or NAD0016A



Please be aware that an important notice concerning availability, standard warranty, and use in critical applications of Texas Instruments semiconductor products and disclaimers thereto appears at the end of this data sheet.

All trademarks are the property of their respective owners.



These devices have limited built-in ESD protection. The leads should be shorted together or the device placed in conductive foam during storage or handling to prevent electrostatic damage to the MOS gates.

### Absolute Maximum Ratings<sup>(1)(2)</sup>

Supply Voltage	7V
Input Voltage	7V
Output Voltage	5.5V
Output Voltage (Power OFF)	-0.25 to 6V
Maximum Power Dissipation <sup>(3)</sup> at 25°C	
Cavity Package	1509 mW
NFG0016E Package	1476 mW
D0016A Package	1051 mW

- (1) "Absolute Maximum Ratings" are those values beyond which the safety of the device cannot be verified. They are not meant to imply that the devices should be operated at these limits. The [Electrical Characteristics](#) provide conditions for actual device operation.
- (2) If Military/Aerospace specified devices are required, please contact the TI Sales Office/Distributors for availability and specifications.
- (3) Derate cavity package 10.1 mW/°C above 25°C; derate molded DIP package 11.9 mW/°C above 25°C; derate SO package 8.41 mW/°C above 25°C.

### Operating Conditions

	Min	Max	Units
Supply Voltage, $V_{CC}$			
DS26LS31M	4.5	5.5	V
DS26LS31	4.75	5.25	V
Temperature, $T_A$			
DS26LS31M	-55	+125	°C
DS26LS31	0	+70	°C

### Electrical Characteristics<sup>(1)(2)(3)</sup>

Parameter		Test Conditions	Min	Typ	Max	Units
$V_{OH}$	Output High Voltage	$I_{OH} = -20$ mA	2.5			V
$V_{OL}$	Output Low Voltage	$I_{OL} = 20$ mA			0.5	V
$V_{IH}$	Input High Voltage		2.0			V
$V_{IL}$	Input Low Voltage				0.8	V
$I_{iL}$	Input Low Current	$V_{IN} = 0.4$ V		-40	-200	μA
$I_{iH}$	Input High Current	$V_{IN} = 2.7$ V			20	μA
$I_i$	Input Reverse Current	$V_{IN} = 7$ V			0.1	mA
$I_O$	TRI-STATE Output Current	$V_O = 2.5$ V			20	μA
		$V_O = 0.5$ V			-20	μA
$V_{CL}$	Input Clamp Voltage	$I_{IN} = -18$ mA			-1.5	V
$I_{SC}$	Output Short-Circuit Current		-30		-150	mA
$I_{CC}$	Power Supply Current	All Outputs Disabled or Active		35	60	mA

- (1) Unless otherwise specified min/max limits apply across the -55°C to +125°C temperature range for the DS26LS31M and across the 0°C to +70°C range for the DS26LS31. All typicals are given for  $V_{CC} = 5$  V and  $T_A = 25$ °C.
- (2) All currents into device pins are positive; all currents out of device pins are negative. All voltages are referenced to ground unless otherwise specified.
- (3) Only one output at a time should be shorted.

### Switching Characteristics

$V_{CC} = 5V, T_A = 25^\circ C$

Parameter	Test Conditions	Min	Typ	Max	Units
$t_{PLH}$	Input to Output $C_L = 30 \text{ pF}$		10	15	ns
$t_{PHL}$	Input to Output $C_L = 30 \text{ pF}$		10	15	ns
Skew	Output to Output $C_L = 30 \text{ pF}$		2.0	6.0	ns
$t_{LZ}$	Enable to Output $C_L = 10 \text{ pF}, S2 \text{ Open}$		15	35	ns
$t_{HZ}$	Enable to Output $C_L = 10 \text{ pF}, S1 \text{ Open}$		15	25	ns
$t_{ZL}$	Enable to Output $C_L = 30 \text{ pF}, S2 \text{ Open}$		20	30	ns
$t_{ZH}$	Enable to Output $C_L = 30 \text{ pF}, S1 \text{ Open}$		20	30	ns

### AC TEST CIRCUIT AND SWITCHING TIME WAVEFORMS

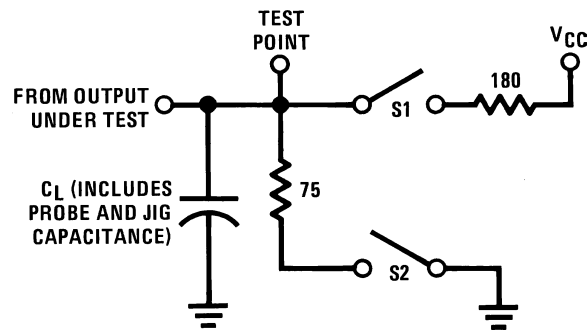

S1 and S2 of load circuit are closed except where shown.

Figure 2. AC Test Circuit

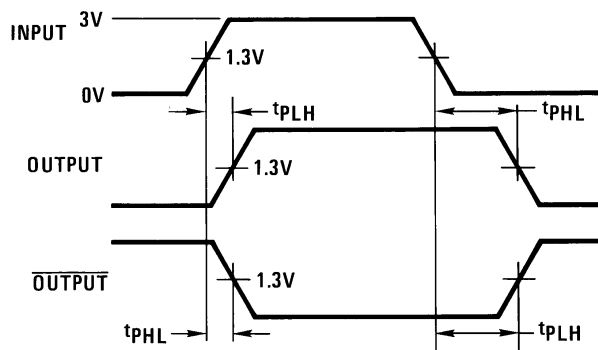

$f = 1 \text{ MHz}, t_r \leq 15 \text{ ns}, t_f \leq 6 \text{ ns}$

Figure 3. Propagation Delays

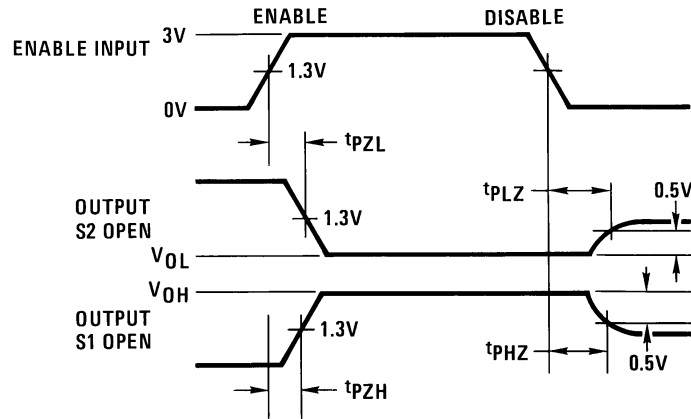

$f = 1 \text{ MHz}$ ,  $t_r \leq 15 \text{ ns}$ ,  $t_f \leq 6 \text{ ns}$

Figure 4. Enable and Disable Times

TYPICAL APPLICATIONS

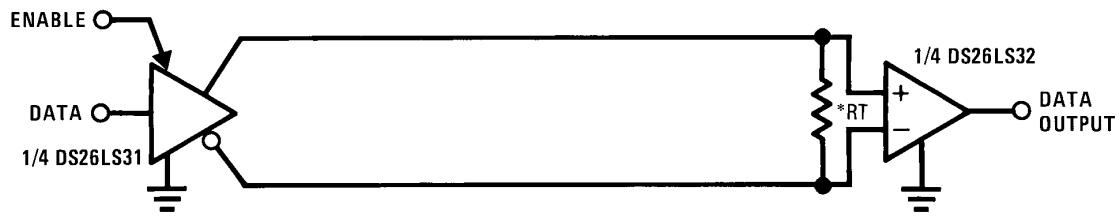

$R_T$  is optional although highly recommended to reduce reflection.

Figure 5. Two-Wire Balanced System, RS-422

Typical Performance Characteristics

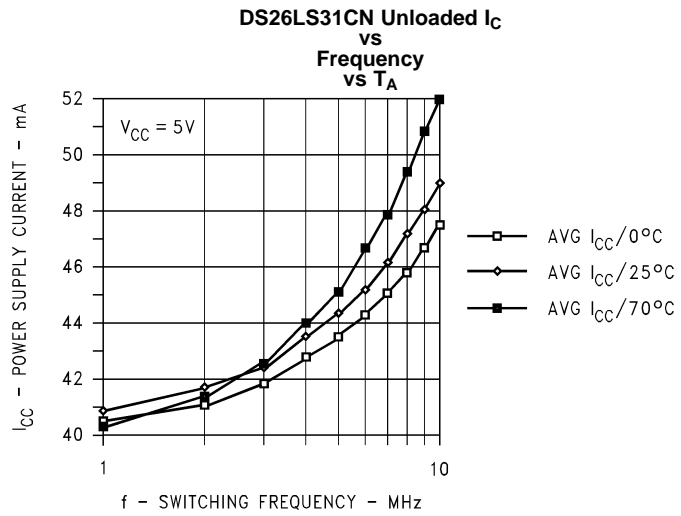

Figure 6.

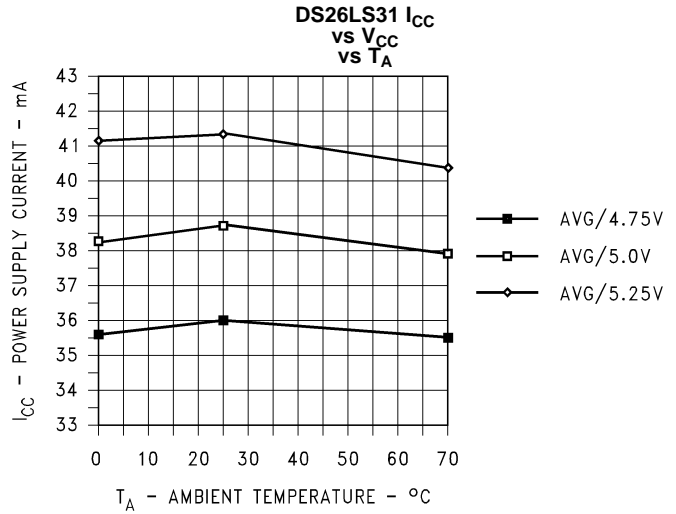

Figure 7.

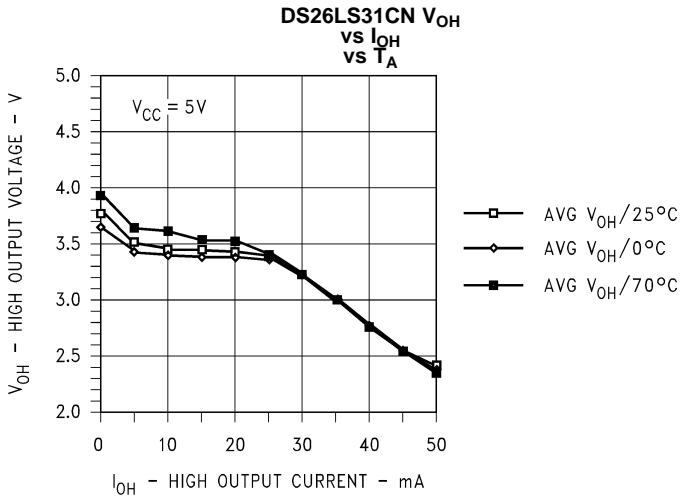

Figure 8.

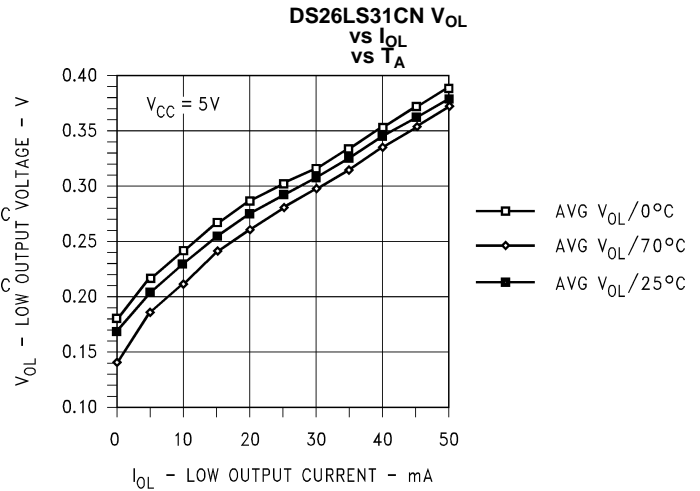

Figure 9.

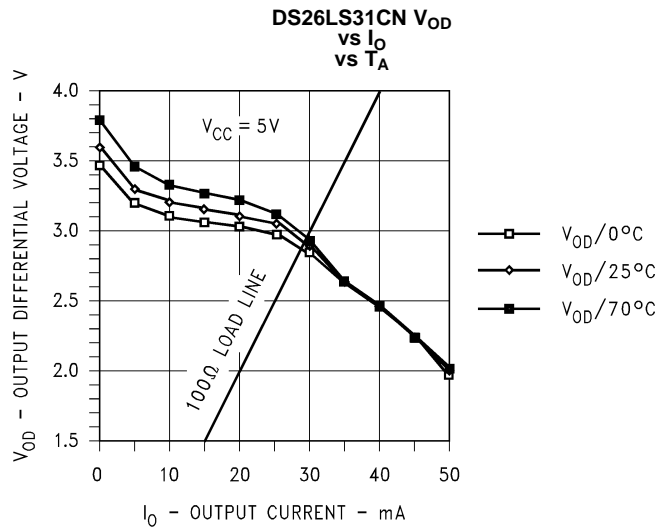

Figure 10.

## REVISION HISTORY

Changes from Revision B (April 2013) to Revision C	Page
• Changed layout of National Data Sheet to TI format .....	<a href="#">5</a>

**PACKAGING INFORMATION**

Orderable Device	Status (1)	Package Type	Package Drawing	Pins	Package Qty	Eco Plan (2)	Lead/Ball Finish (6)	MSL Peak Temp (3)	Op Temp (°C)	Device Marking (4/5)	Samples
AM26LS31PC	NRND	PDIP	NFG	16	25	TBD	Call TI	Call TI	0 to 70	DS26LS31CN AM26LS31PC	
DS26LS31CM	LIFEBUY	SOIC	D	16	48	TBD	Call TI	Call TI	0 to 70	DS26LS31CM	
DS26LS31CM/NOPB	ACTIVE	SOIC	D	16	48	Green (RoHS & no Sb/Br)	CU SN	Level-1-260C-UNLIM	0 to 70	DS26LS31CM	<b>Samples</b>
DS26LS31CMX	LIFEBUY	SOIC	D	16	2500	TBD	Call TI	Call TI	0 to 70	DS26LS31CM	
DS26LS31CMX/NOPB	ACTIVE	SOIC	D	16	2500	Green (RoHS & no Sb/Br)	CU SN	Level-1-260C-UNLIM	0 to 70	DS26LS31CM	<b>Samples</b>
DS26LS31CN	LIFEBUY	PDIP	NFG	16	25	TBD	Call TI	Call TI	0 to 70	DS26LS31CN AM26LS31PC	
DS26LS31CN/NOPB	ACTIVE	PDIP	NFG	16	25	Pb-Free (RoHS)	CU SN	Level-1-NA-UNLIM	0 to 70	DS26LS31CN AM26LS31PC	<b>Samples</b>
DS26LS31N	NRND	PDIP	NFG	16	25	TBD	Call TI	Call TI	0 to 70	DS26LS31CN AM26LS31PC	

(1) The marketing status values are defined as follows:

**ACTIVE:** Product device recommended for new designs.

**LIFEBUY:** TI has announced that the device will be discontinued, and a lifetime-buy period is in effect.

**NRND:** Not recommended for new designs. Device is in production to support existing customers, but TI does not recommend using this part in a new design.

**PREVIEW:** Device has been announced but is not in production. Samples may or may not be available.

**OBSOLETE:** TI has discontinued the production of the device.

(2) Eco Plan - The planned eco-friendly classification: Pb-Free (RoHS), Pb-Free (RoHS Exempt), or Green (RoHS & no Sb/Br) - please check <http://www.ti.com/productcontent> for the latest availability information and additional product content details.

**TBD:** The Pb-Free/Green conversion plan has not been defined.

**Pb-Free (RoHS):** TI's terms "Lead-Free" or "Pb-Free" mean semiconductor products that are compatible with the current RoHS requirements for all 6 substances, including the requirement that lead not exceed 0.1% by weight in homogeneous materials. Where designed to be soldered at high temperatures, TI Pb-Free products are suitable for use in specified lead-free processes.

**Pb-Free (RoHS Exempt):** This component has a RoHS exemption for either 1) lead-based flip-chip solder bumps used between the die and package, or 2) lead-based die adhesive used between the die and leadframe. The component is otherwise considered Pb-Free (RoHS compatible) as defined above.

**Green (RoHS & no Sb/Br):** TI defines "Green" to mean Pb-Free (RoHS compatible), and free of Bromine (Br) and Antimony (Sb) based flame retardants (Br or Sb do not exceed 0.1% by weight in homogeneous material)

(3) MSL, Peak Temp. - The Moisture Sensitivity Level rating according to the JEDEC industry standard classifications, and peak solder temperature.

(4) There may be additional marking, which relates to the logo, the lot trace code information, or the environmental category on the device.

<sup>(5)</sup> Multiple Device Markings will be inside parentheses. Only one Device Marking contained in parentheses and separated by a "~" will appear on a device. If a line is indented then it is a continuation of the previous line and the two combined represent the entire Device Marking for that device.

<sup>(6)</sup> Lead/Ball Finish - Orderable Devices may have multiple material finish options. Finish options are separated by a vertical ruled line. Lead/Ball Finish values may wrap to two lines if the finish value exceeds the maximum column width.

**Important Information and Disclaimer:**The information provided on this page represents TI's knowledge and belief as of the date that it is provided. TI bases its knowledge and belief on information provided by third parties, and makes no representation or warranty as to the accuracy of such information. Efforts are underway to better integrate information from third parties. TI has taken and continues to take reasonable steps to provide representative and accurate information but may not have conducted destructive testing or chemical analysis on incoming materials and chemicals. TI and TI suppliers consider certain information to be proprietary, and thus CAS numbers and other limited information may not be available for release.

In no event shall TI's liability arising out of such information exceed the total purchase price of the TI part(s) at issue in this document sold by TI to Customer on an annual basis.



## TAPE AND REEL INFORMATION



### QUADRANT ASSIGNMENTS FOR PIN 1 ORIENTATION IN TAPE



\*All dimensions are nominal

Device	Package Type	Package Drawing	Pins	SPQ	Reel Diameter (mm)	Reel Width W1 (mm)	A0 (mm)	B0 (mm)	K0 (mm)	P1 (mm)	W (mm)	Pin1 Quadrant
DS26LS31CMX	SOIC	D	16	2500	330.0	16.4	6.5	10.3	2.3	8.0	16.0	Q1
DS26LS31CMX/NOPB	SOIC	D	16	2500	330.0	16.4	6.5	10.3	2.3	8.0	16.0	Q1

**TAPE AND REEL BOX DIMENSIONS**

\*All dimensions are nominal

Device	Package Type	Package Drawing	Pins	SPQ	Length (mm)	Width (mm)	Height (mm)
DS26LS31CMX	SOIC	D	16	2500	367.0	367.0	35.0
DS26LS31CMX/NOPB	SOIC	D	16	2500	367.0	367.0	35.0

NFG0016E

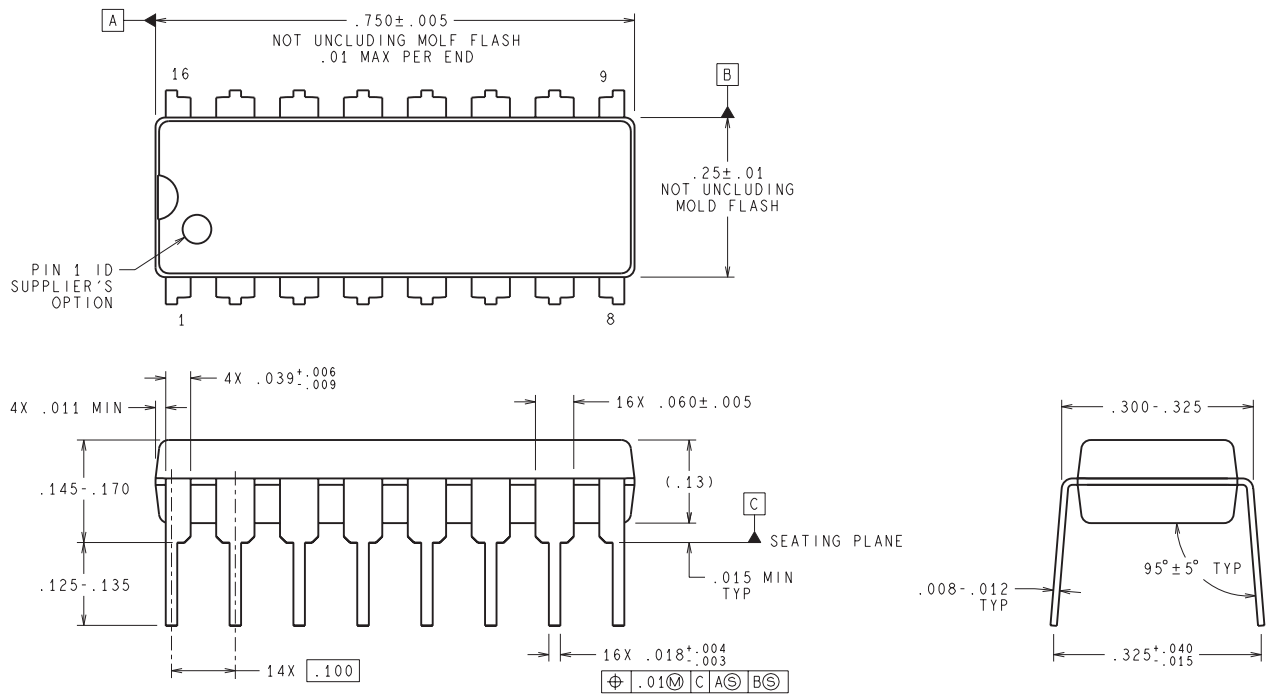

DIMENSIONS ARE IN INCHES  
DIMENSIONS IN ( ) FOR REFERENCE ONLY

N16E (Rev G)



## IMPORTANT NOTICE

Texas Instruments Incorporated and its subsidiaries (TI) reserve the right to make corrections, enhancements, improvements and other changes to its semiconductor products and services per JESD46, latest issue, and to discontinue any product or service per JESD48, latest issue. Buyers should obtain the latest relevant information before placing orders and should verify that such information is current and complete. All semiconductor products (also referred to herein as "components") are sold subject to TI's terms and conditions of sale supplied at the time of order acknowledgment.

TI warrants performance of its components to the specifications applicable at the time of sale, in accordance with the warranty in TI's terms and conditions of sale of semiconductor products. Testing and other quality control techniques are used to the extent TI deems necessary to support this warranty. Except where mandated by applicable law, testing of all parameters of each component is not necessarily performed.

TI assumes no liability for applications assistance or the design of Buyers' products. Buyers are responsible for their products and applications using TI components. To minimize the risks associated with Buyers' products and applications, Buyers should provide adequate design and operating safeguards.

TI does not warrant or represent that any license, either express or implied, is granted under any patent right, copyright, mask work right, or other intellectual property right relating to any combination, machine, or process in which TI components or services are used. Information published by TI regarding third-party products or services does not constitute a license to use such products or services or a warranty or endorsement thereof. Use of such information may require a license from a third party under the patents or other intellectual property of the third party, or a license from TI under the patents or other intellectual property of TI.

Reproduction of significant portions of TI information in TI data books or data sheets is permissible only if reproduction is without alteration and is accompanied by all associated warranties, conditions, limitations, and notices. TI is not responsible or liable for such altered documentation. Information of third parties may be subject to additional restrictions.

Resale of TI components or services with statements different from or beyond the parameters stated by TI for that component or service voids all express and any implied warranties for the associated TI component or service and is an unfair and deceptive business practice. TI is not responsible or liable for any such statements.

Buyer acknowledges and agrees that it is solely responsible for compliance with all legal, regulatory and safety-related requirements concerning its products, and any use of TI components in its applications, notwithstanding any applications-related information or support that may be provided by TI. Buyer represents and agrees that it has all the necessary expertise to create and implement safeguards which anticipate dangerous consequences of failures, monitor failures and their consequences, lessen the likelihood of failures that might cause harm and take appropriate remedial actions. Buyer will fully indemnify TI and its representatives against any damages arising out of the use of any TI components in safety-critical applications.

In some cases, TI components may be promoted specifically to facilitate safety-related applications. With such components, TI's goal is to help enable customers to design and create their own end-product solutions that meet applicable functional safety standards and requirements. Nonetheless, such components are subject to these terms.

No TI components are authorized for use in FDA Class III (or similar life-critical medical equipment) unless authorized officers of the parties have executed a special agreement specifically governing such use.

Only those TI components which TI has specifically designated as military grade or "enhanced plastic" are designed and intended for use in military/aerospace applications or environments. Buyer acknowledges and agrees that any military or aerospace use of TI components which have **not** been so designated is solely at the Buyer's risk, and that Buyer is solely responsible for compliance with all legal and regulatory requirements in connection with such use.

TI has specifically designated certain components as meeting ISO/TS16949 requirements, mainly for automotive use. In any case of use of non-designated products, TI will not be responsible for any failure to meet ISO/TS16949.

### Products

Audio	<a href="http://www.ti.com/audio">www.ti.com/audio</a>
Amplifiers	<a href="http://amplifier.ti.com">amplifier.ti.com</a>
Data Converters	<a href="http://dataconverter.ti.com">dataconverter.ti.com</a>
DLP® Products	<a href="http://www.dlp.com">www.dlp.com</a>
DSP	<a href="http://dsp.ti.com">dsp.ti.com</a>
Clocks and Timers	<a href="http://www.ti.com/clocks">www.ti.com/clocks</a>
Interface	<a href="http://interface.ti.com">interface.ti.com</a>
Logic	<a href="http://logic.ti.com">logic.ti.com</a>
Power Mgmt	<a href="http://power.ti.com">power.ti.com</a>
Microcontrollers	<a href="http://microcontroller.ti.com">microcontroller.ti.com</a>
RFID	<a href="http://www.ti-rfid.com">www.ti-rfid.com</a>
OMAP Applications Processors	<a href="http://www.ti.com/omap">www.ti.com/omap</a>
Wireless Connectivity	<a href="http://www.ti.com/wirelessconnectivity">www.ti.com/wirelessconnectivity</a>

### Applications

Automotive and Transportation	<a href="http://www.ti.com/automotive">www.ti.com/automotive</a>
Communications and Telecom	<a href="http://www.ti.com/communications">www.ti.com/communications</a>
Computers and Peripherals	<a href="http://www.ti.com/computers">www.ti.com/computers</a>
Consumer Electronics	<a href="http://www.ti.com/consumer-apps">www.ti.com/consumer-apps</a>
Energy and Lighting	<a href="http://www.ti.com/energy">www.ti.com/energy</a>
Industrial	<a href="http://www.ti.com/industrial">www.ti.com/industrial</a>
Medical	<a href="http://www.ti.com/medical">www.ti.com/medical</a>
Security	<a href="http://www.ti.com/security">www.ti.com/security</a>
Space, Avionics and Defense	<a href="http://www.ti.com/space-avionics-defense">www.ti.com/space-avionics-defense</a>
Video and Imaging	<a href="http://www.ti.com/video">www.ti.com/video</a>

### TI E2E Community

[e2e.ti.com](http://e2e.ti.com)