

Video Equalizer (3D+C) for DVI, HDMI Source/Repeater/Sink Applications

Check for Samples: [DS16EV5110A](#)

FEATURES

- **8 Levels of Equalization Settable by 3 Pins or Through the SMBus Interface**
- **DC-Coupled Inputs and Outputs**
- **Optimized for Operation From 250 Mbps to 2.25 Gbps in Support of UXGA, 480 I/P, 720 I/P, 1080 I, and 1080 P With 8, 10, and 12-Bit Color Depth Resolutions**
- **Two DS16EV5110A Devices Support DVI/HDMI Dual Link**
- **DVI 1.0, and HDMI 1.3a Compatible TMDS Interface**
- **Clock Channel Signal Detect (LOS)**
- **Enable for Power Savings Standby Mode**
- **System Management Bus (SMBus) Provides Control of Boost, Output Amplitude, Enable, and Clock Channel Signal Detect Threshold**
- **Low Power Consumption: 475mW (Typical)**
- **0.13 UI Total Jitter at 1.65 Gbps Including Cable**
- **Single 3.3V Power Supply**
- **Small 7mm x 7mm, 48-Pin Leadless WQFN Package**
- **-40°C to +85°C Operating Temperature Range**
- **Extends TMDS Cable Reach Over:**
 1. **> 40 Meters 24 AWG DVI Cable (1.65Gbps)**
 2. **> 20 Meters 28 AWG DVI Cable (1.65Gbps)**
 3. **> 20 Meters Cat5/Cat5e/Cat6 Cables (1.65Gbps)**
 4. **> 20 Meters 28 AWG HDMI Cables (2.25Gbps)**

APPLICATIONS

- **HDMI / DVI Cable Extenders**
- **HDMI / DVI Switches**
- **Projectors**
- **High Definition Displays**

DESCRIPTION

The DS16EV5110A is a multi-channel equalizer optimized for video cable extension Source/Repeater/Sink Applications. It operates between 250Mbps and 2.25Gbps with common applications at 1.65Gbps and 2.25Gbps (per data channel). It contains three Transition-Minimized Differential Signaling (TMDS) data channels and one clock channel as specified for DVI and HDMI interfaces. It provides compensation for skin-effect and dielectric losses, a common phenomenon when transmitting video on commercially available high definition video cables.

The inputs conform to DVI and HDMI requirements and features programmable levels of input equalization. The programmable levels of equalization provide optimal signal boost and reduces inter-symbol interference. Eight levels of boost are selectable via a pin interface or by the optional System Management Bus.

The clock channel is optimized for clock rates of up to 225 MHz and features a signal detect circuit. To maximize noise immunity, the DS16EV5110A features a signal detector with programmable thresholds. The threshold is adjustable through a System Management Bus (SMBus) interface.

The DS16EV5110A may be used in Source Applications, Sink Applications, or as a Repeater.

The DS16EV5110A also provides support for system power management via output enable controls. Additional controls are provided via the SMBus enabling customization and optimization for specific applications requirements. These controls include programmable features such as output amplitude and boost controls as well as system level diagnostics.

The DS16EV5110A is a pin-for-pin replacement to the DS16EV5110. It features an enhanced CML output that presents a high impedance when powered down.



Please be aware that an important notice concerning availability, standard warranty, and use in critical applications of Texas Instruments semiconductor products and disclaimers thereto appears at the end of this data sheet.

All trademarks are the property of their respective owners.

Typical Application

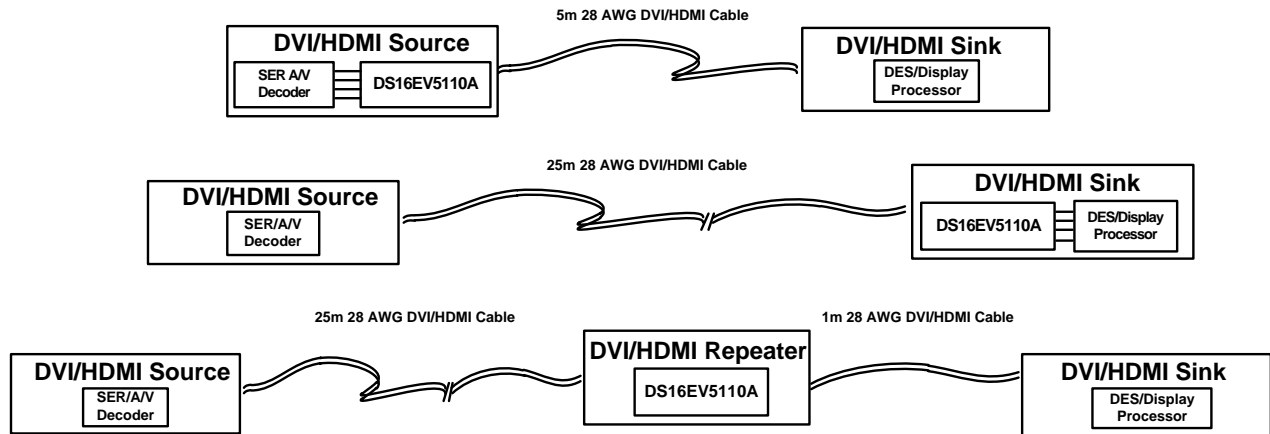

PIN DESCRIPTIONS

Pin Name	Pin Number	I/O ⁽¹⁾ , Type	Description
HIGH SPEED DIFFERENTIAL I/O			
C_IN-	1	I, CML	Inverting and non-inverting TMDS Clock inputs to the equalizer. An on-chip 50Ω terminating resistor connects C_IN+ to VDD and C_IN- to VDD.
C_IN+	2	I, CML	
D_IN0-	4	I, CML	Inverting and non-inverting TMDS Data inputs to the equalizer. An on-chip 50Ω terminating resistor connects D_IN0+ to VDD and D_IN0- to VDD.
D_IN0+	5	I, CML	
D_IN1-	8	I, CML	Inverting and non-inverting TMDS Data inputs to the equalizer. An on-chip 50Ω terminating resistor connects D_IN1+ to VDD and D_IN1- to VDD.
D_IN1+	9	I, CML	
D_IN2-	11	I, CML	Inverting and non-inverting TMDS Data inputs to the equalizer. An on-chip 50Ω terminating resistor connects D_IN2+ to VDD and D_IN2- to VDD.
D_IN2+	12	I, CML	
C_OUT-	36	O, CML	Inverting and non-inverting TMDS outputs from the equalizer. Open collector.
C_OUT+	35	O, CML	
D_OUT0-	33	O, CML	Inverting and non-inverting TMDS outputs from the equalizer. Open collector.
D_OUT0+	32	O, CML	
D_OUT1-	29	O, CML	Inverting and non-inverting TMDS outputs from the equalizer. Open collector.
D_OUT1+	28	O, CML	
D_OUT2-	26	O, CML	Inverting and non-inverting TMDS outputs from the equalizer. Open collector.
D_OUT2+	25	O, CML	
Equalization Control			
BST_0	23	I, LVCMOS	BST_0, BST_1, and BST_2 select the equalizer boost level for EQ channels. BST_0, BST_1, and BST_2 are internally pulled Low. See Table 2 .
BST_1	14	I, LVCMOS	
BST_2	37	I, LVCMOS	
Device Control			
EN	44	I, LVCMOS	Enable Equalizer input. When held High, normal operation is selected. When held Low, standby mode is selected. EN is internally pulled High. Signal is global to all Data and Clock channels.
FEB	21	I, LVCMOS	Force External Boost. When held High, the equalizer boost setting is controlled by the BST_0[0:2] pins. When held Low, the equalizer boost level is controlled through the SMBus (see Table 1) control pins. FEB is internally pulled High.
SD	45	O, LVCMOS	Equalizer Clock Channel Signal Detect Output. Produces a High when signal is detected.
POWER			
V _{DD}	3, 6, 7, 10, 13, 15, 46	Power	V _{DD} pins should be tied to the V _{DD} plane through a low inductance path. A 0.1μF bypass capacitor should be connected between each V _{DD} pin to the GND planes.
GND	22, 24, 27, 30, 31, 34	GND	Ground reference. GND should be tied to a solid ground plane through a low impedance path.
Exposed Pad	DAP	GND	The exposed pad at the center of the package must be connected to the ground plane.

(1) Note: I = Input, O = Output, IO = Input/Output,

PIN DESCRIPTIONS (continued)

Pin Name	Pin Number	I/O ⁽¹⁾ , Type	Description
System Management Bus (SMBus) Interface Control Pins			
SDA	18	IO, LVCMOS	SMBus Data Input / Output. Internally pulled High to 3.3V with High-Z pull up.
SDC	17	I, LVCMOS	SMBus Clock Input. Internally pulled High to 3.3V with High-Z pull up.
CS	16	I, LVCMOS	SMBus Chip select. When held High, the equalizer SMBus register is enabled. When held Low, the equalizer SMBus register is disabled. CS is internally pulled Low. CS is internally gated with SDC.
Other			
Reserv	19, 20, 38, 39, 40, 41, 42, 43, 47, 48		Reserved. Do not connect.

Connection Diagram

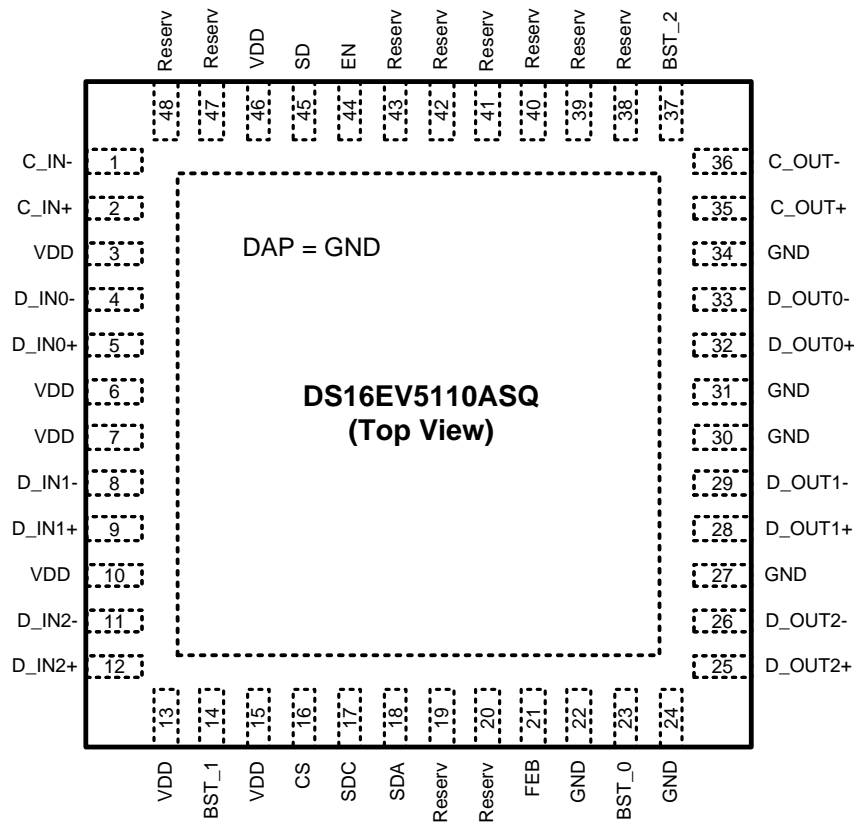

TOP VIEW — Not to Scale



These devices have limited built-in ESD protection. The leads should be shorted together or the device placed in conductive foam during storage or handling to prevent electrostatic damage to the MOS gates.

Absolute Maximum Ratings⁽¹⁾⁽²⁾

Supply Voltage (V_{DD})		-0.5V to +4.0V
LVC MOS Input Voltage		-0.5V + 4.0V
LVC MOS Output Voltage		-0.5V to 4.0V
CML Input/Output Voltage		-0.5V to 4.0V
Junction Temperature		+150°C
Storage Temperature		-65°C to +150°C
Lead Temperature (Soldering, 5 sec.)		+260°C
ESD Rating	HBM, 1.5 kΩ, 100 pF	>6 kV
Thermal Resistance	θ_{JA} , No Airflow	30°C/W

- (1) "Absolute Maximum Ratings" indicate limits beyond which damage to the device may occur, including inoperability and degradation of device reliability and/or performance. Functional operation of the device and/or non-degradation at the Absolute Maximum Ratings or other conditions beyond those indicated in the Recommended Operating Conditions is not implied. The Recommended Operating Conditions indicate conditions at which the device is functional and the device should not be operated beyond such conditions. Absolute Maximum Numbers are ensured for a junction temperature range of -40°C to +125°C. Models are validated to Maximum Operating Voltages only.
- (2) If Military/Aerospace specified devices are required, please contact the TI Sales Office/Distributors for availability and specifications.

Recommended Operating Conditions^{(1) (2)}

	Min	Typ	Max	Units
Supply Voltage (V_{DD} to GND)	3.0	3.3	3.6	V
Ambient Temperature	-40	25	+85	°C

- (1) Typical values represent most likely parametric norms at $V_{DD} = 3.3V$, $T_A = 25^\circ C$, and at the Recommended Operation Conditions at the time of product characterization and are not ensured.
- (2) The [Electrical Characteristics](#) tables list ensured specifications under the listed Recommended Operating Conditions except as otherwise modified or specified by the Electrical Characteristics Conditions and/or Notes.

Electrical Characteristics

Over recommended operating supply and temperature ranges unless other specified. ^{(1) (2)}

Symbol	Parameter	Conditions	Min	Typ	Max	Units
LVC MOS DC SPECIFICATIONS						
I_{IH-PU}	High Level Input Leakage Current	LVC MOS pins with internal pull-up resistors	-10		+10	μA
I_{IH-PD}	High Level Input Leakage Current	LVC MOS pins with internal pull-down resistors	80		105	μA
I_{IL-PU}	Low Level Input Leakage Current	LVC MOS pins with internal pull-up resistors	-20		-10	μA
I_{IL-PD}	Low Level Input Leakage Current	LVC MOS pins with internal pull-down resistors	-10		+10	μA
V_{IH}	High Level Input Voltage		2.0		V_{DD}	V
V_{IL}	Low Level Input Voltage		0		0.8	V
V_{OH}	High Level Output Voltage	SD Pin, $I_{OH} = -3mA$	2.4			V
V_{OL}	Low Level Output Voltage	SD Pin, $I_{OL} = 3mA$			0.4	V
POWER						
PD	Power Dissipation	EN = High, Device Enabled		475	700	mW
		EN = Low, Power Down Mode			70	mW

- (1) Typical values represent most likely parametric norms at $V_{DD} = 3.3V$, $T_A = 25^\circ C$, and at the Recommended Operation Conditions at the time of product characterization and are not ensured.
- (2) The [Electrical Characteristics](#) tables list ensured specifications under the listed Recommended Operating Conditions except as otherwise modified or specified by the Electrical Characteristics Conditions and/or Notes.

Electrical Characteristics (continued)

 Over recommended operating supply and temperature ranges unless other specified. ⁽¹⁾ ⁽²⁾

Symbol	Parameter	Conditions	Min	Typ	Max	Units
N	Supply Noise Tolerance ⁽³⁾	DC to 50MHz		100		mV _{P-P}
CML INPUTS						
V _{TX}	Input Voltage Swing (Launch Amplitude)	Measured differentially at TPA (Figure 2)	800		1200	mV _{P-P}
V _{ICMDC}	Input Common-Mode Voltage	DC-Coupled Requirement Measured at TPA (Figure 2)	V _{DD} -0.3		V _{DD} -0.2	V
V _{IN}	Input Voltage Swing	Measured differentially at TPB (Figure 2)		120		mV _{P-P}
R _{LI}	Differential Input Return Loss	100 MHz– 825 MHz, with fixture's effect de-embedded		10		dB
R _{IN}	Input Resistance	IN+ to VDD and IN- to VDD	45	50	55	Ω
CML OUTPUTS						
V _O	Output Voltage Swing	Measured differentially with OUT+ and OUT- terminated by 50Ω to VDD	800		1200	mV _{P-P}
V _{OCM}	Output common-mode Voltage	Measured Single-ended	V _{DD} -0.3		V _{DD} -0.2	V
I _{OFF}	Output Leakage Current	V _{OUT} = 3.6V, V _{DD} = open or 0V		±1		μA
t _R , t _F	Transition Time	20% to 80% of differential output voltage, measured within 1" from output pins.	75		240	ps
t _{CCSK}	Inter Pair Channel-to-Channel Skew (all 4 Channels)	Difference in 50% crossing between shortest and longest channels		25		ps
t _D	Latency			350		ps
OUTPUT JITTER						
TJ1	Total Jitter at 1.65 Gbps	20m 28 AWG STP DVI Cable Data Paths EQ Setting 0x04 PRBS7 ⁽⁴⁾ ⁽⁵⁾ ⁽⁶⁾		0.13	0.17	UI _{P-P}
TJ2	Total Jitter at 2.25 Gbps	20m 28 AWG STP DVI Cable Data Paths EQ Setting 0x04 PRBS7 ⁽⁴⁾ ⁽⁵⁾ ⁽⁶⁾		0.2		UI _{P-P}
TJ3	Total Jitter at 165 MHz	Clock Paths Clock Pattern ⁽⁴⁾ ⁽⁵⁾ ⁽⁶⁾			0.165	UI _{P-P}
TJ4	Total Jitter at 225 MHz	Clock Paths Clock Pattern ⁽⁴⁾ ⁽⁵⁾ ⁽⁶⁾		0.165		UI _{P-P}
RJ	Random Jitter	See ⁽⁶⁾ ⁽⁷⁾		3		ps _{rms}
BIT RATE						
F _{CLK}	Clock Frequency	Clock Path ⁽⁴⁾	25		225	MHz
BR	Bit Rate	Data Path ⁽⁴⁾	0.25		2.25	Gbps

(3) Allowed supply noise (mV_{P-P} sine wave) under typical conditions.

(4) Specification is ensured by characterization and is not tested in production.

(5) Deterministic jitter is measured at the differential outputs (TPC of Figure 2), minus the deterministic jitter before the test channel (TPA of Figure 2). Random jitter is removed through the use of averaging or similar means.

(6) Total Jitter is defined as peak-to-peak deterministic jitter from ⁽⁵⁾ + 14.2 times random jitter in ps_{rms}.

(7) Random jitter contributed by the equalizer is defined as $\sqrt{J_{OUT}^2 - J_{IN}^2}$. J_{OUT} is the random jitter at equalizer outputs in ps_{rms}, see TPC of Figure 2; J_{IN} is the random jitter at the input of the equalizer in ps_{rms}, see TPA of Figure 2.

Electrical Characteristics — System Management Bus Interface ^{(1) (2)}

Over recommended operating supply and temperature ranges unless other specified.

Symbol	Parameter	Conditions	Min	Typ	Max	Units
System Bus Interface — DC Specifications						
V _{IL}	Data, Clock Input Low Voltage				0.8	V
V _{IH}	Data, Clock Input High Voltage		2.8		V _{DD}	V
I _{PULLUP}	Current through pull-up resistor or current source	V _{OL} = 0.4V		10		mA
V _{DD}	Nominal Bus Voltage		3.0		3.6	V
I _{LEAK-Bus}	Input Leakage per bus segment	⁽³⁾	-200		+200	μA
I _{LEAK-Pin}	Input Leakage per device pin			-15		μA
C _I	Capacitance for SDA and SDC	^{(3) (4)}			10	pF
R _{TERM}	Termination Resistance	V _{DD3.3} , ^{(3) (4) (5)}		1000		Ω
System Bus Interface Timing Specification						
FSMB	Bus Operating Frequency	⁽⁶⁾	10		100	kHz
TBUF	Bus Free Time Between Stop and Start Condition		4.7			μs
TSU:CS	Minimum time between SMB_CS being active and start condition	⁽⁷⁾	30			ns
TH:CS	Minimum time between stop condition and releasing SMB_CS	⁽⁷⁾	100			ns
THD:STA	Hold Time After (Repeated) Start Condition. First CLK generated after this period.	At I _{PULLUP} , Max	4.0			μs
TSU:STA	Repeated Start Condition Setup Time		4.7			μs
TSU:STO	Stop Condition Setup Time		4.0			μs
THD:DAT	Data Hold Time		300			ns
TSU:DAT	Data Setup Time		250			ns
T _{TIMEOUT}	Detect Clock Low Timeout	⁽⁶⁾	25		35	ms
T _{LOW}	Clock Low Period		4.7			μs
T _{HIGH}	Clock High Period	⁽⁶⁾	4.0		50	μs
T _{LOW:SEXT}	Cumulative Clock Low Extend Time (Slave Device)	⁽⁶⁾			2	ms
t _F	Clock/Data Fall Time	⁽⁶⁾			300	ns
t _R	Clock/Data Rise Time	⁽⁶⁾			1000	ns
t _{POR}	Time in which a device must be operational after power-on reset	⁽⁶⁾			500	ms

- (1) Typical values represent most likely parametric norms at V_{DD} = 3.3V, T_A = 25°C, and at the Recommended Operation Conditions at the time of product characterization and are not ensured.
- (2) The [Electrical Characteristics](#) tables list ensured specifications under the listed Recommended Operating Conditions except as otherwise modified or specified by the Electrical Characteristics Conditions and/or Notes.
- (3) Recommended value. Parameter not tested in production.
- (4) Recommended maximum capacitance load per bus segment is 400pF.
- (5) Maximum termination voltage should be identical to the device supply voltage.
- (6) Compliant to SMBus 2.0 physical layer specification. See System Management Bus (SMBus) Specification Version 2.0, section 3.1.1 SMBus common AC specifications for details.
- (7) Specification is ensured by characterization and is not tested in production.

TIMING DIAGRAMS

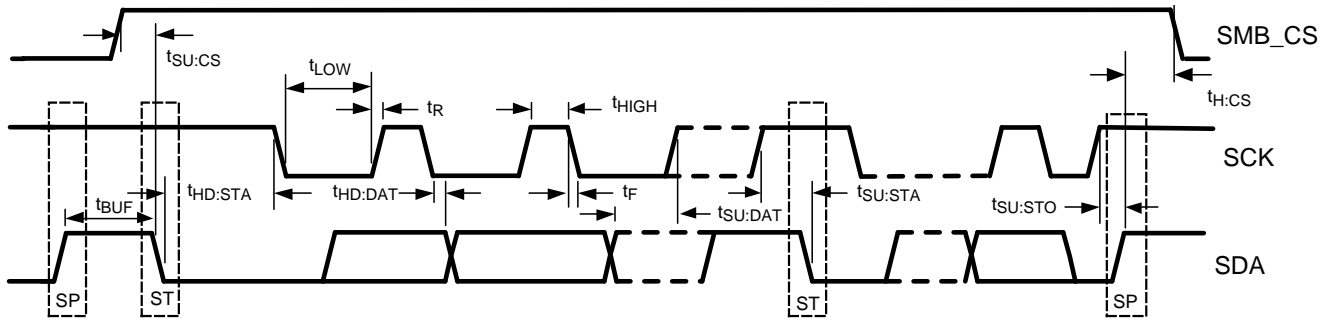

Figure 1. SMBus Timing Diagram

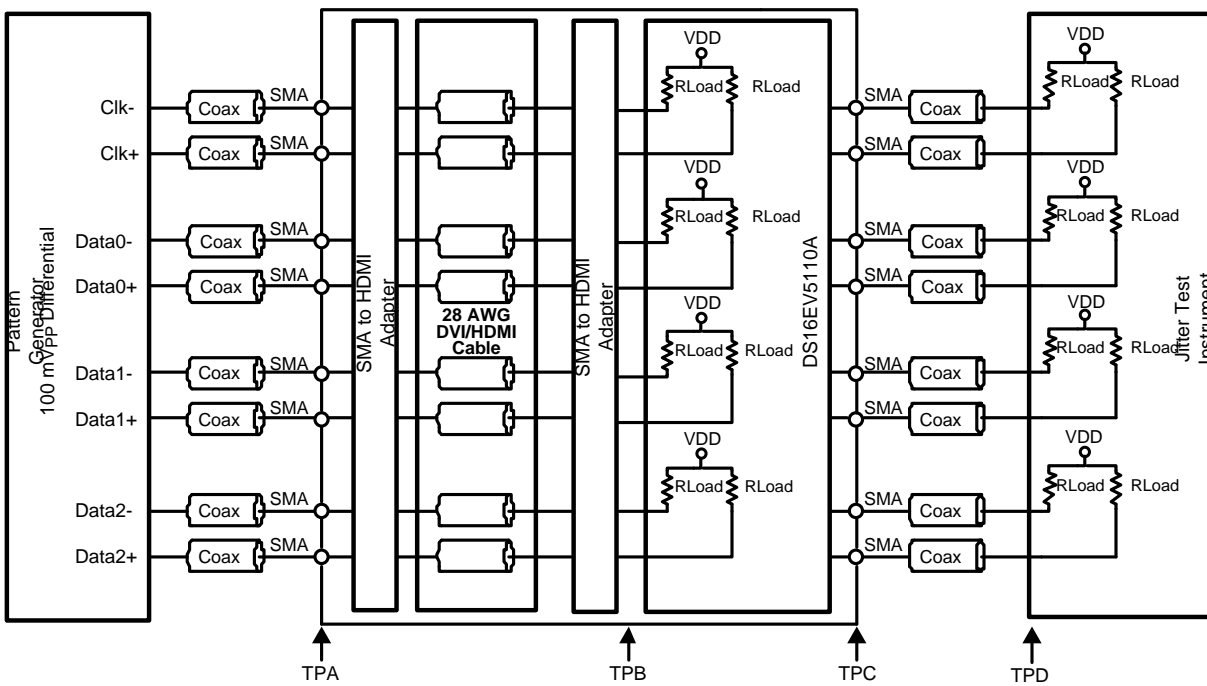

Figure 2. Test Setup Diagram for Jitter Measurement

SYSTEM MANAGEMENT BUS (SMBUS) AND CONFIGURATION REGISTERS

The System Management Bus interface is compatible to SMBus 2.0 physical layer specification. The use of the Chip Select signal is **required**. Holding the CS pin High enables the SMBus port allowing access to the configuration registers. Holding the CS pin Low disables the device's SMBus allowing communication from the host to other slave devices on the bus. In the STANDBY state, the System Management Bus remains active. When communication to other devices on the SMBus is active, the CS signal for the DS16EV5110As must be driven Low.

The address byte for all DS16EV5110As is AC'h. Based on the SMBus 2.0 specification, the DS16EV5110A has a 7-bit slave address of 1010110'b. The LSB is set to 0'b (for a WRITE), thus the 8-bit value is 1010 1100 'b or AC'h.

The SDC and SDA pins are 3.3V LVCMOS signaling and include high-Z internal pull up resistors. External low impedance pull up resistors maybe required depending upon SMBus loading and speed. Note, these pins are not 5V tolerant.

Transfer of Data via the SMBus

During normal operation the data on SDA must be stable during the time when SDC is High.

There are three unique states for the SMBus:

START: A High-to-Low transition on SDA while SDC is High indicates a message START condition.

STOP: A Low-to-High transition on SDA while SDC is High indicates a message STOP condition.

IDLE: If SDC and SDA are both High for a time exceeding t_{BUF} from the last detected STOP condition or if they are High for a total exceeding the maximum specification for t_{HIGH} then the bus will transfer to the IDLE state.

SMBus Transactions

The device supports WRITE and READ transactions. See [Table 1](#) for register address, type (Read/Write, Read Only), default value and function information.

Writing a Register

To write a register, the following protocol is used (see SMBus 2.0 specification).

1. The Host (Master) selects the device by driving its SMBus Chip Select (CS) signal High.
2. The Host drives a START condition, the 7-bit SMBus address, and a "0" indicating a WRITE.
3. The Device (Slave) drives the ACK bit ("0").
4. The Host drives the 8-bit Register Address.
5. The Device drives an ACK bit ("0").
6. The Host drive the 8-bit data byte.
7. The Device drives an ACK bit ("0").
8. The Host drives a STOP condition.
9. The Host de-selects the device by driving its SMBus CS signal Low.

The WRITE transaction is completed, the bus goes IDLE and communication with other SMBus devices may now occur.

Reading a Register

To read a register, the following protocol is used (see SMBus 2.0 specification).

1. The Host (Master) selects the device by driving its SMBus Chip Select (CS) signal High.
2. The Host drives a START condition, the 7-bit SMBus address, and a "0" indicating a WRITE.
3. The Device (Slave) drives the ACK bit ("0").
4. The Host drives the 8-bit Register Address.
5. The Device drives an ACK bit ("0").
6. The Host drives a START condition.
7. The Host drives the 7-bit SMBus Address, and a "1" indicating a READ.
8. The Device drives an ACK bit "0".

9. The Device drives the 8-bit data value (register contents).
10. The Host drives a NACK bit “1” indicating end of the READ transfer.
11. The Host drives a STOP condition.
12. The Host de-selects the device by driving its SMBus CS signal Low.

The READ transaction is completed, the bus goes IDLE and communication with other SMBus devices may now occur.

Please see [Table 1](#) for more information.

Table 1. SMBus Register Descriptions

Name	Address	Default	Type ⁽¹⁾	Bit 7	Bit 6	Bit 5	Bit 4	Bit 3	Bit 2	Bit 1	Bit 0	
Status	0x00	0x00	RO	ID Revision				Reserved	Reserved	Reserved	SD	
Status	0x01	0x00	RO	Reserved	Boost 1			EN	Reserved			
Status	0x02	0x00	RO	Reserved	Boost 3			Reserved	Boost 2			
Internal Enable/ Individual Channel Boost Control for C_IN±, D_IN0±	0x03	0x77	RW	EN (Int.) 0:Enable 1:Disable (D_IN0±)	Boost Control (BC for CH0) 000 (Min Boost) 001 010 011 100 101 110 111 (Max Boost)			EN (Int.) 0:Enable 1:Disable (C_IN±)	Reserved			
Individual Channel Boost Control for D_IN1±, D_IN2±	0x04	0x77	RW	EN (Int.) 0:Enable 1:Disable (D_IN2±)	Boost Control (BC for CH2) 000 (Min Boost) 001 010 011 100 101 110 111 (Max Boost)			EN (Int.) 0:Enable 1:Disable (D_IN1±)	Boost Control (BC for CH1) 000 (Min Boost) 001 010 011 100 101 110 111 (Max Boost)			
Signal Detect ON (SD_ON)	0x05	0x00	RW	Reserved					Threshold (mV)			
									00: 70 (Default) 01: 55 10: 90 11: 75			
Signal Detect OFF (SD_OFF)	0x06	0x00	RW	Reserved					Threshold (mV)			
									00: 40 (Default) 01: 30 10: 55 11: 45			
SMBus or CMOS Control for EN	0x07	0x00	RW	Reserved							SMBus Enable 0: Disable 1: Enable	
Output Level	0x08	0x78	RW	Reserved				Output Level: 00: 540 mVp-p 01: 770 mVp-p 10: 1000 mVp-p 11: 1200 mVp-p		Reserved		

(1) Note: RO = Read Only, RW = Read/Write

DS16EV5110A DEVICE DESCRIPTION

The DS16EV5110A video equalizer comprises three data channels, a clock channel, and a control interface including a System Management Bus (SMBus) port.

DATA CHANNELS

The DS16EV5110A provides three data channels. Each data channel consists of an equalizer stage, a limiting amplifier, a DC offset correction block, and a TMDS driver as shown in [Figure 3](#).

EQUALIZER BOOST CONTROL

The data channel equalizers support eight programmable levels of equalization boost. The state of the FEB pin determines how the boost settings are controlled. If the FEB pin is held High, then the equalizer boost setting is controlled by the Boost Set pins (BST_[0:2]) in accordance with [Table 2](#). If this programming method is chosen, then the boost setting selected on the Boost Set pins is applied to all three data channels. When the FEB pin is held Low, the equalizer boost level is controlled through the SMBus. This programming method is accessed via the appropriate SMBus registers (see [Table 1](#)). Using this approach, equalizer boost settings can be programmed for each channel individually. FEB is internally pulled High (default setting); therefore if left unconnected, the boost settings are controlled by the Boost Set pins (BST_[0:2]). The range of boost settings provided enables the DS16EV5110A to address a wide range of transmission line path loss scenarios, enabling support for a variety of data rates and formats.

Table 2. EQ Boost Control Table

Control Via SMBus BC_2, BC_1, BC_0 (FEB = 0)	Control Via Pins BST_2, BST_1, BST_0 (FEB = 1)	EQ Boost Setting at 825 MHz (dB) (TYP)
000	000	9
001	001	14
010	010	18
011	011	21
100	100	24
101	101	26
110	110	28
111	111	30

DEVICE STATE AND ENABLE CONTROL

The DS16EV5110A has an Enable feature which provides the ability to control device power consumption. This feature can be controlled either via the Enable Pin (EN Pin) or via the Enable Control Bit which is accessed through the SMBus port (see [Table 1](#) and [Table 3](#)). If Enable is activated, the data channels and clock channel are placed in the ACTIVE state and all device blocks function as described. The DS16EV5110A can also be placed in STANDBY mode to save power. In this mode only the control interface including the SMBus port as well as the clock channel signal detection circuit remain active.

Table 3. Enable and Device State Control

Register 07[0] (SMBus)	EN Pin (CMOS)	Register 03[3] (EN Control) (SMBus)	Device State
0 : Disable	1	X	ACTIVE
0 : Disable	0	X	STANDBY
1 : Enable	X	0	ACTIVE
1 : Enable	X	1	STANDBY

CLOCK CHANNEL

The clock channel incorporates a limiting amplifier, a DC offset correction, and a TMD5 driver as shown in Figure 4.

CLOCK CHANNEL SIGNAL DETECT

The DS16EV5110A features a signal detect circuit on the clock channel. The status of the clock signal can be determined by either reading the Signal Detect bit (SD) in the SMBus registers (see Table 1) or by the state of the SD pin. A logic High indicates the presence of a signal that has exceeded a specified threshold value (called SD_ON). A logic Low means that the clock signal has fallen below a threshold value (called SD_OFF). These values are programmed via the SMBus (Table 1). If not programmed via the SMBus, the thresholds take on the default values for the SD_OFF and SD_ON values as indicated in Table 4. The Signal Detect threshold values can be changed through the SMBus. All threshold values specified are DC peak-to-peak differential signals (positive signal minus negative signal) at the input of the device.

Table 4. Clock Channel Signal Detect Threshold Values

Bit 1	Bit 0	SD_OFF Threshold Register 06 (mV)	SD_ON Threshold Register 05 (mV)
0	0	40 (Default)	70 (Default)
0	1	30	55
1	0	55	90
1	1	45	75

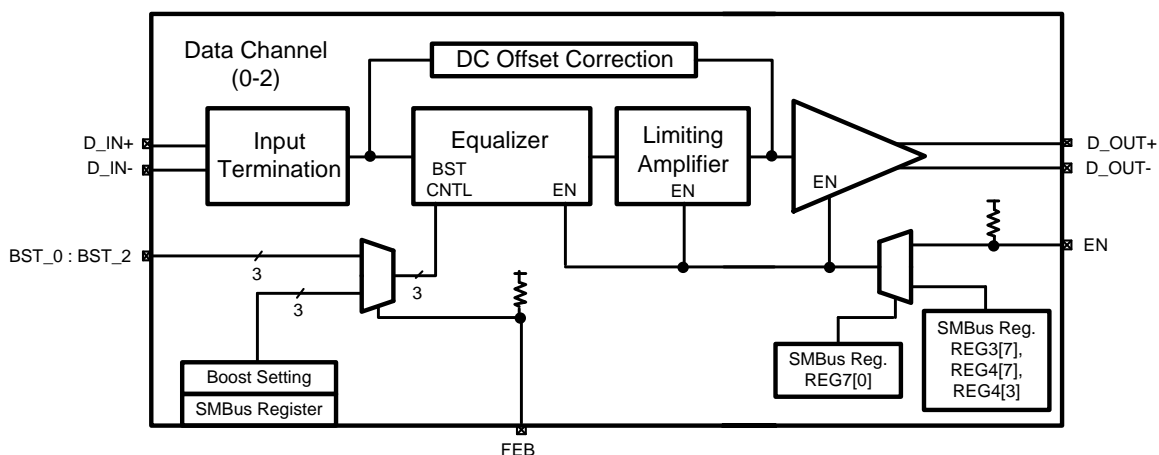

Figure 3. DS16EV5110A Data Channel

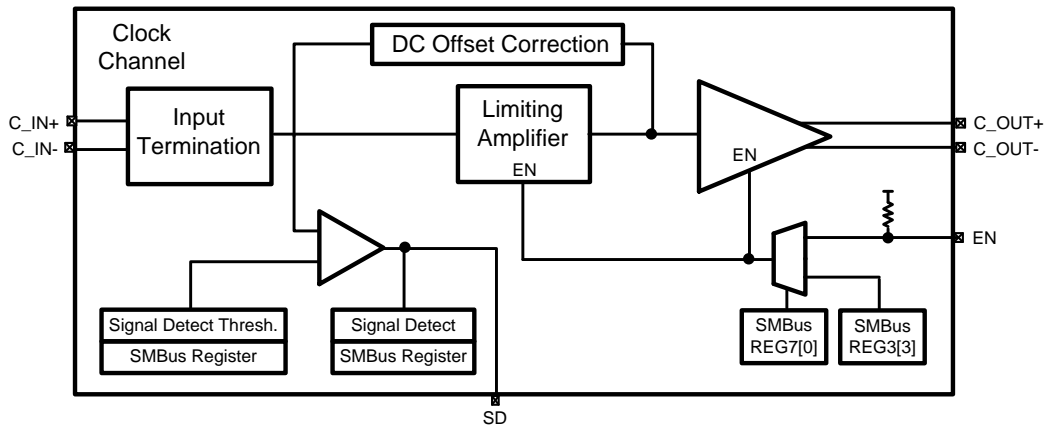

Figure 4. DS16EV5110A Clock Channel

OUTPUT LEVEL CONTROL

The output amplitude of the TMDs drivers for both the data channels and the clock channel can be controlled via the SMBus (see Table 1). The default output level is 1000mV p-p. The following Table presents the output level values supported:

Table 5. Output Level Control Settings – REG 0x08[3:2]

Bit 3	Bit 2	Output Level (mV)
0	0	540
0	1	770
1	0	1000 (default)
1	1	1200

AUTOMATIC ENABLE FEATURE

It may be desired for the DS16EV5110A to be configured to automatically enter STANDBY mode if no clock signal is present. STANDBY mode can be implemented by connecting the Signal Detect (SD) pin to the external (LVCMOS) Enable (EN) pin. In order for this option to function properly, REG07[0] should be set to a “0” (default value). If the clock signal applied to the clock channel input swings above the SD_ON threshold specified in the threshold register via the SMBus, then the SD pin is asserted High. If the SD pin is connected to the EN pin, this will enable the equalizer, limiting amplifier, and output buffer on the data channels and the limiting amplifier and output buffer on the clock channel; thus the DS16EV5110A will automatically enter the ACTIVE state. If the clock signal present falls below SD_OFF threshold specified in the threshold register, then the SD pin will be asserted Low, causing the aforementioned blocks to be placed in the STANDBY state.

APPLICATION INFORMATION

The DS16EV5110A is used to recondition DVI/HDMI video signals or differential signals with similar characteristics for signal loss and degradation due to transmission through a length of shielded or unshielded cable. The DS16EV5110A maybe used on the Source or Sink side of the application or as a Repeater (Sink and Source).

In the Source Side application the DS16EV5110A is located near the Serializer and conditions the signal for losses due to internal cabling or FR4 losses (backplane). The signal is then re-driven at full amplitude and reduced jitter over the external cable interconnect.

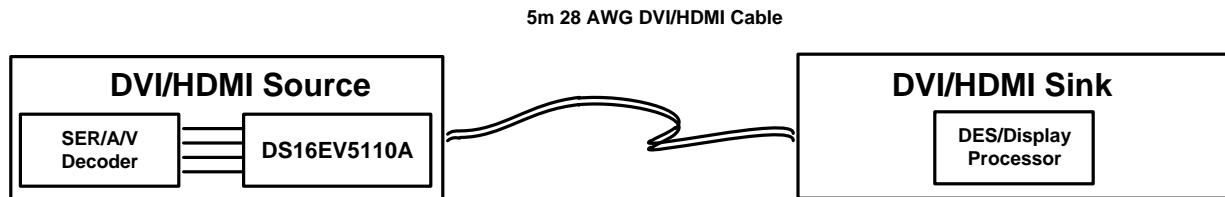

Figure 5. DS16EV5110A Source-Side Application

In the Sink Side application the DS16EV5110A is located next to the Deserializer and post-conditions the signal for losses incurred over the cable interconnect.

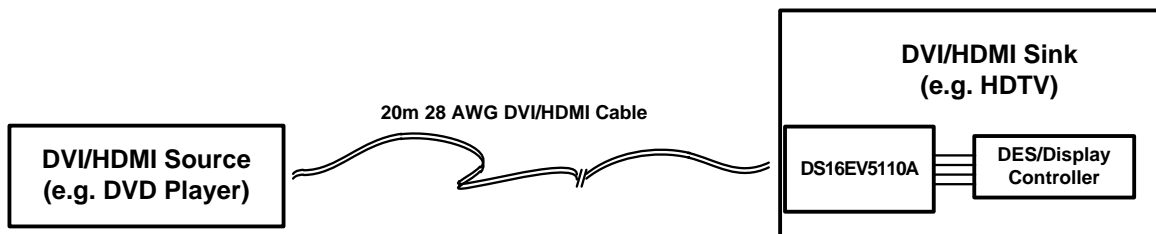

Figure 6. DS16EV5110A Sink-Side Application

The DS16EV5110A may be used in repeater type application as shown in Figure 7 . The cable on the output of the repeater tends to be shorter and may be a dongle type application. The input of the repeater recovers the signal after transmission over a long cable interconnect.

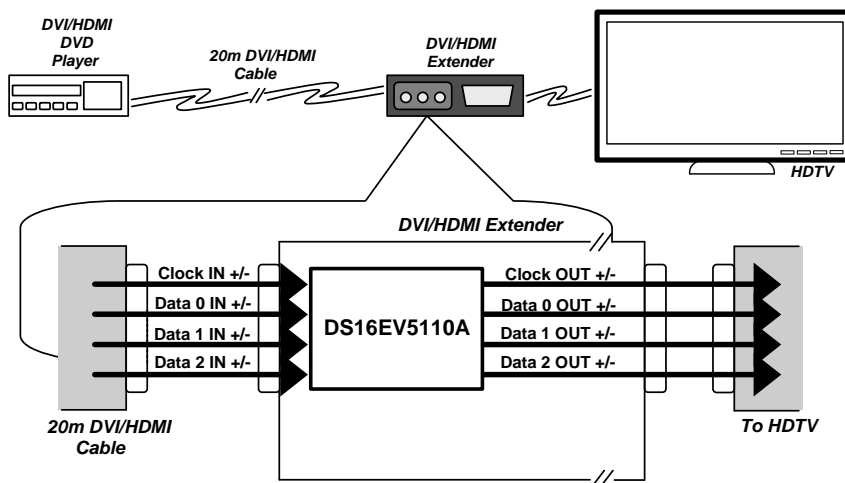

Figure 7. DS16EV5110A Repeater Application with CAT 5 Cable

In general, the use of multiple equalizers is not recommended due to accumulation of random jitter.

DVI 1.0 AND HDMI V1.2a APPLICATIONS

A single DS16EV5110A can be used to implement cable extension solutions with various resolutions and screen refresh rates. The range of digital serial rates supported is between 250 Mbps and 1.65 Gbps. For applications requiring ultra-high resolution for DVI applications (e.g., QXGA and WQXGA), a “dual link” TMDS interface is required. This is easily configured by using two DS16EV5110A devices as shown in [Figure 8](#).

Note the recommended connections between LVCMOS control pins. This provides the Automatic Enable feature for both devices based on the one active clock channel. In many applications the SMBus is not required (device is pin controlled), for this application simply leave the three SMBus pins open. SDC and SDA are internally pulled High, and CS is internally pulled Low, thus the SMBus is in the disabled state.

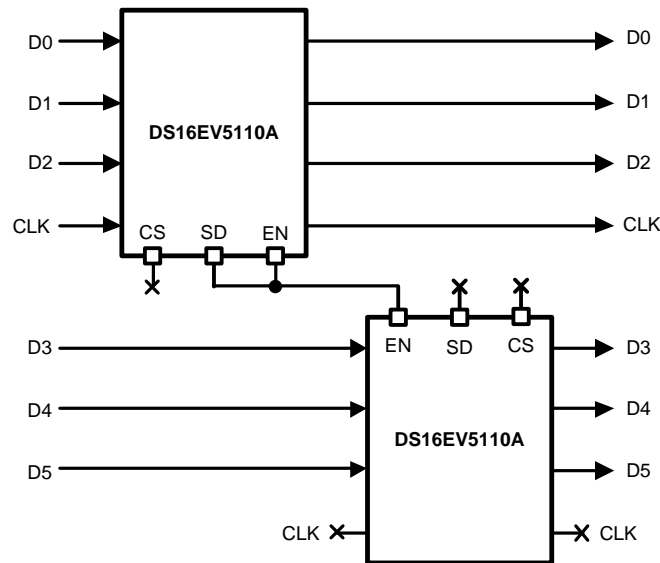

Figure 8. Connection in Dual Link Application

HDMI V1.3 APPLICATION

The DS16EV5110A can reliably extend operation to distances greater than 20 meters of 28 AWG HDMI cable at 2.25 Gbps, thereby supporting HDMI v1.3 for 1080p HDTV resolution with 12-bit color depth. Please note that the Electrical Characteristics specified in this document have not been tested for and are not ensured for 2.25 Gbps operation.

DC COUPLED DATA PATHS AND DVI/HDMI COMPLIANCE

The DS16EV5110A is designed to support TMDS differential pairs with DC coupled transmission lines. It contains integrated termination resistors (50Ω), pulled up to VDD at the input stage, and open collector outputs for DVI / HDMI for signal swing.

CABLE SELECTION

At higher frequencies, longer cable lengths produce greater losses due to the skin effect. The quality of the cable with respect to conductor wire gauge and shielding heavily influences performance. Thicker conductors have lower signal degradation per unit length. In nearly all applications, the DS16EV5110A equalization can be set to 0x04, and equalize up to 22 dB skin effect loss for all input cable configurations at all data rates, without degrading signal integrity.

28 AWG STP DVI / HDMI CABLES RECOMMENDED BOOST SETTINGS

The following table presents the recommended boost control settings for various data rates and cable lengths for 28 AWG DVI/HDMI compliant configurations. Boost setting maybe done via the three BST[2:0] pins or via the respective register values.

Table 6. Boost Control Setting for STP Cables

Setting	Data Rate	28 AWG DVI / HDMI
0x04	750 Mbps	0–25m
0x04	1.65 Gbps	0–20m
0x06	750 Mbps	25m to greater than 30m
0x06	1.65 Gbps	20m to greater than 25m
0x03	2.25 Gbps	0–15m
0x06	2.25 Gbps	15m to greater than 20m

Figure 9 shows the cable extension and jitter reduction obtained with the use of the equalizer. Table 6 lists the various gain settings used versus cable length recommendations.

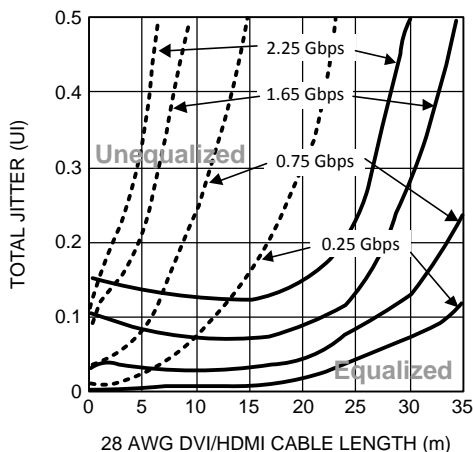

Figure 9. Equalized vs. Unequalized Jitter Performance Over 28 AWG DVI/HDMI Cable

UTP (UNSHIELDED TWIST PAIRS) CABLES

The DS16EV5110A can be used to extend the length of UTP cables, such as Cat5, Cat5e and Cat6 to distances greater than 20 meters at 1.65 Gbps with < 0.13 UI of jitter. Please note that for non-standard DVI/HDMI cables, the user must ensure the clock-to-data channel skew requirements are met. Table 7 presents the recommended boost control settings for various data rates and cable lengths for UTP configurations:

Table 7. Boost Control Setting for UTP Cables

Setting	Data Rate	Cat5 Cable
0x03	750 Mbps	0–25m
0x06	750 Mbps	25–45m
0x03	1.65 Gbps	Greater than 20m

Figure 10 shows the cable extension and jitter reduction obtained with the use of the equalizer. Table 7 lists the various gain settings used versus cable length recommendations.

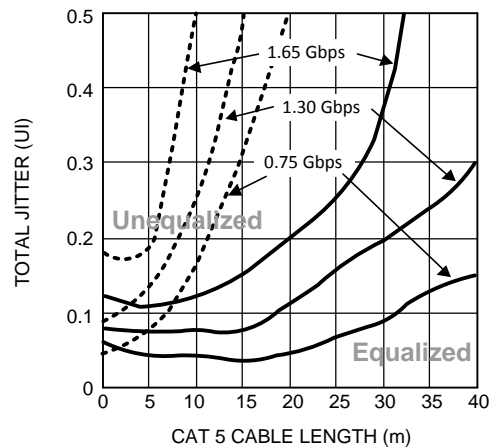

Figure 10. Equalized vs. Unequalized Jitter Performance Over Cat5 Cable

General Recommendations

The DS16EV5110A is a high performance circuit capable of delivering excellent performance. Careful attention must be paid to the details associated with high-speed design as well as providing a clean power supply. Refer to the LVDS Owner's Manual for more detailed information on high-speed design tips as well as many other available resources available addressing signal integrity design issues.

PCB LAYOUT CONSIDERATIONS FOR DIFFERENTIAL PAIRS

The TMDS differential inputs and outputs must have a controlled differential impedance of 100Ω. It is preferable to route TMDS lines exclusively on one layer of the board, particularly for the input traces. The use of vias should be avoided if possible. If vias must be used, they should be used sparingly and must be placed symmetrically for each side of a given differential pair. Route the TMDS signals away from other signals and noise sources on the printed circuit board. All traces of TMDS differential inputs and outputs must be equal in length to minimize intra-pair skew.

WQFN FOOTPRINT RECOMMENDATIONS

See application note AN-1187 (SNOA401) for additional information on WQFN packages footprint and soldering information.

POWER SUPPLY BYPASSING

Two approaches are recommended to ensure that the DS16EV5110A is provided with an adequate power supply. First, the supply (VDD) and ground (GND) pins should be connected to power planes routed on adjacent layers of the printed circuit board. The layer thickness of the dielectric should be minimized so that the VDD and GND planes create a low inductance supply with distributed capacitance. Second, careful attention to supply bypassing through the proper use of bypass capacitors is required. A 0.1μF bypass capacitor should be connected to each VDD pin such that the capacitor is placed as close as possible to the DS16EV5110A. Smaller body size capacitors can help facilitate proper component placement. Additionally, three capacitors with capacitance in the range of 2.2μF to 10μF should be incorporated in the power supply bypassing design as well. These capacitors can be either tantalum or an ultra-low ESR ceramic and should be placed as close as possible to the DS16EV5110A.

EQUIVALENT I/O STRUCTURES

Figure 11 shows the DS16EV5110A CML output structure and ESD protection circuitry.

Figure 12 shows the DS16EV5110A CML input structure and ESD protection circuitry.

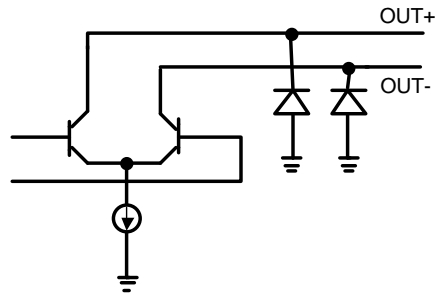

Figure 11. Equivalent CML Output Structure

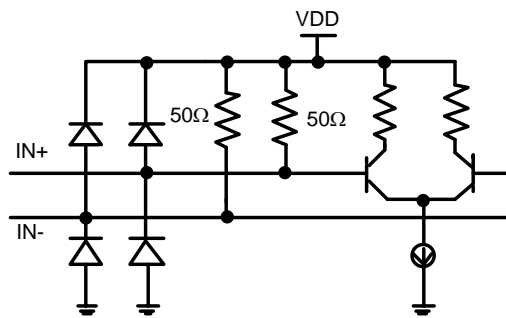

Figure 12. Equivalent CML Input Structure

Typical Performance Characteristics

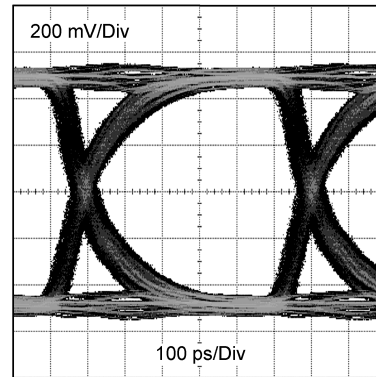
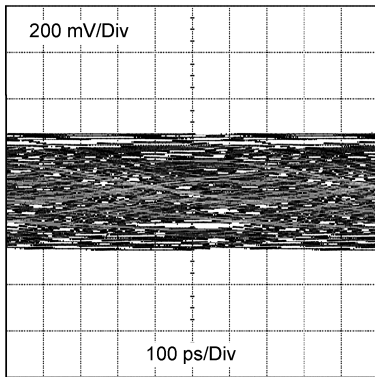

Figure 13. Un-Equalized vs. Equalized Signal after 25m of 28 AWG DVI Cable at 1.65 Gbps (0x06 Setting)

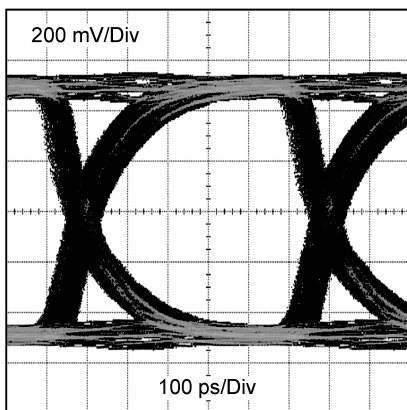

Figure 14. Output Signal after 20m of Cat5 Cable at 1.65 Gbps (0x06 Setting)

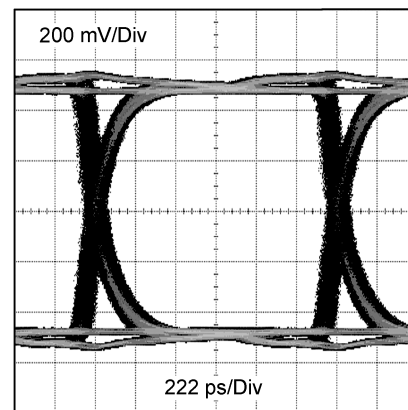

Figure 15. Output Signal after 30m of 28 AWG DVI Cable at 750 Mbps (0x06 Setting)

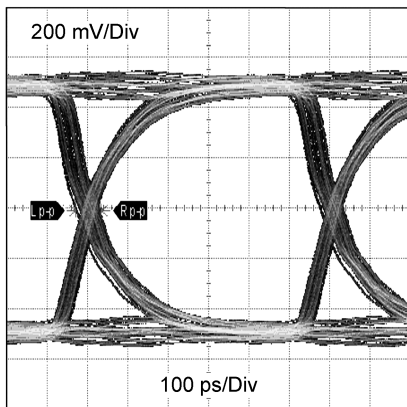

Figure 16. Output Signal after 0.3m of 28 AWG DVI Cable at 1.65 Gbps (0x04 Setting)

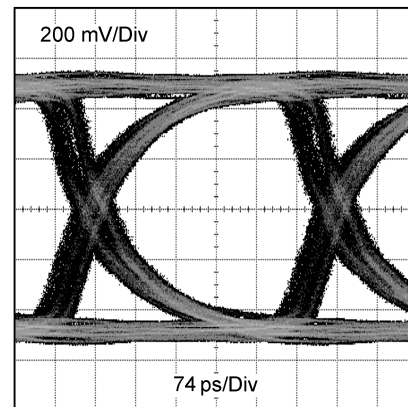

Figure 17. Output Signal after 20m of 28 AWG HDMI Cable at 2.25 Gbps (0x06 Setting)

REVISION HISTORY

Changes from Revision B (April 2013) to Revision C	Page
• Changed layout of National Data Sheet to TI format	18

PACKAGING INFORMATION

Orderable Device	Status (1)	Package Type	Package Drawing	Pins	Package Qty	Eco Plan (2)	Lead/Ball Finish (6)	MSL Peak Temp (3)	Op Temp (°C)	Device Marking (4/5)	Samples
DS16EV5110ASQ/NOPB	ACTIVE	WQFN	NJU	48	1000	Green (RoHS & no Sb/Br)	CU SN	Level-3-260C-168 HR	-40 to 85	D16EV511A	Samples
DS16EV5110ASQE/NOPB	ACTIVE	WQFN	NJU	48	250	Green (RoHS & no Sb/Br)	CU SN	Level-3-260C-168 HR	-40 to 85	D16EV511A	Samples
DS16EV5110ASQX/NOPB	ACTIVE	WQFN	NJU	48	2500	Green (RoHS & no Sb/Br)	CU SN	Level-3-260C-168 HR	-40 to 85	D16EV511A	Samples

(1) The marketing status values are defined as follows:

ACTIVE: Product device recommended for new designs.

LIFEBUY: TI has announced that the device will be discontinued, and a lifetime-buy period is in effect.

NRND: Not recommended for new designs. Device is in production to support existing customers, but TI does not recommend using this part in a new design.

PREVIEW: Device has been announced but is not in production. Samples may or may not be available.

OBsolete: TI has discontinued the production of the device.

(2) Eco Plan - The planned eco-friendly classification: Pb-Free (RoHS), Pb-Free (RoHS Exempt), or Green (RoHS & no Sb/Br) - please check <http://www.ti.com/productcontent> for the latest availability information and additional product content details.

TBD: The Pb-Free/Green conversion plan has not been defined.

Pb-Free (RoHS): TI's terms "Lead-Free" or "Pb-Free" mean semiconductor products that are compatible with the current RoHS requirements for all 6 substances, including the requirement that lead not exceed 0.1% by weight in homogeneous materials. Where designed to be soldered at high temperatures, TI Pb-Free products are suitable for use in specified lead-free processes.

Pb-Free (RoHS Exempt): This component has a RoHS exemption for either 1) lead-based flip-chip solder bumps used between the die and package, or 2) lead-based die adhesive used between the die and leadframe. The component is otherwise considered Pb-Free (RoHS compatible) as defined above.

Green (RoHS & no Sb/Br): TI defines "Green" to mean Pb-Free (RoHS compatible), and free of Bromine (Br) and Antimony (Sb) based flame retardants (Br or Sb do not exceed 0.1% by weight in homogeneous material)

(3) MSL, Peak Temp. - The Moisture Sensitivity Level rating according to the JEDEC industry standard classifications, and peak solder temperature.

(4) There may be additional marking, which relates to the logo, the lot trace code information, or the environmental category on the device.

(5) Multiple Device Markings will be inside parentheses. Only one Device Marking contained in parentheses and separated by a "~" will appear on a device. If a line is indented then it is a continuation of the previous line and the two combined represent the entire Device Marking for that device.

(6) Lead/Ball Finish - Orderable Devices may have multiple material finish options. Finish options are separated by a vertical ruled line. Lead/Ball Finish values may wrap to two lines if the finish value exceeds the maximum column width.

Important Information and Disclaimer: The information provided on this page represents TI's knowledge and belief as of the date that it is provided. TI bases its knowledge and belief on information provided by third parties, and makes no representation or warranty as to the accuracy of such information. Efforts are underway to better integrate information from third parties. TI has taken and

continues to take reasonable steps to provide representative and accurate information but may not have conducted destructive testing or chemical analysis on incoming materials and chemicals. TI and TI suppliers consider certain information to be proprietary, and thus CAS numbers and other limited information may not be available for release.

In no event shall TI's liability arising out of such information exceed the total purchase price of the TI part(s) at issue in this document sold by TI to Customer on an annual basis.

TAPE AND REEL INFORMATION

QUADRANT ASSIGNMENTS FOR PIN 1 ORIENTATION IN TAPE

*All dimensions are nominal

Device	Package Type	Package Drawing	Pins	SPQ	Reel Diameter (mm)	Reel Width W1 (mm)	A0 (mm)	B0 (mm)	K0 (mm)	P1 (mm)	W (mm)	Pin1 Quadrant
DS16EV5110ASQ/NOPB	WQFN	NJU	48	1000	330.0	16.4	7.3	7.3	1.3	12.0	16.0	Q1
DS16EV5110ASQE/NOPB	WQFN	NJU	48	250	178.0	16.4	7.3	7.3	1.3	12.0	16.0	Q1
DS16EV5110ASQX/NOPB	WQFN	NJU	48	2500	330.0	16.4	7.3	7.3	1.3	12.0	16.0	Q1

TAPE AND REEL BOX DIMENSIONS

*All dimensions are nominal

Device	Package Type	Package Drawing	Pins	SPQ	Length (mm)	Width (mm)	Height (mm)
DS16EV5110ASQ/NOPB	WQFN	NJU	48	1000	367.0	367.0	38.0
DS16EV5110ASQE/NOPB	WQFN	NJU	48	250	213.0	191.0	55.0
DS16EV5110ASQX/NOPB	WQFN	NJU	48	2500	367.0	367.0	38.0

NJU0048D

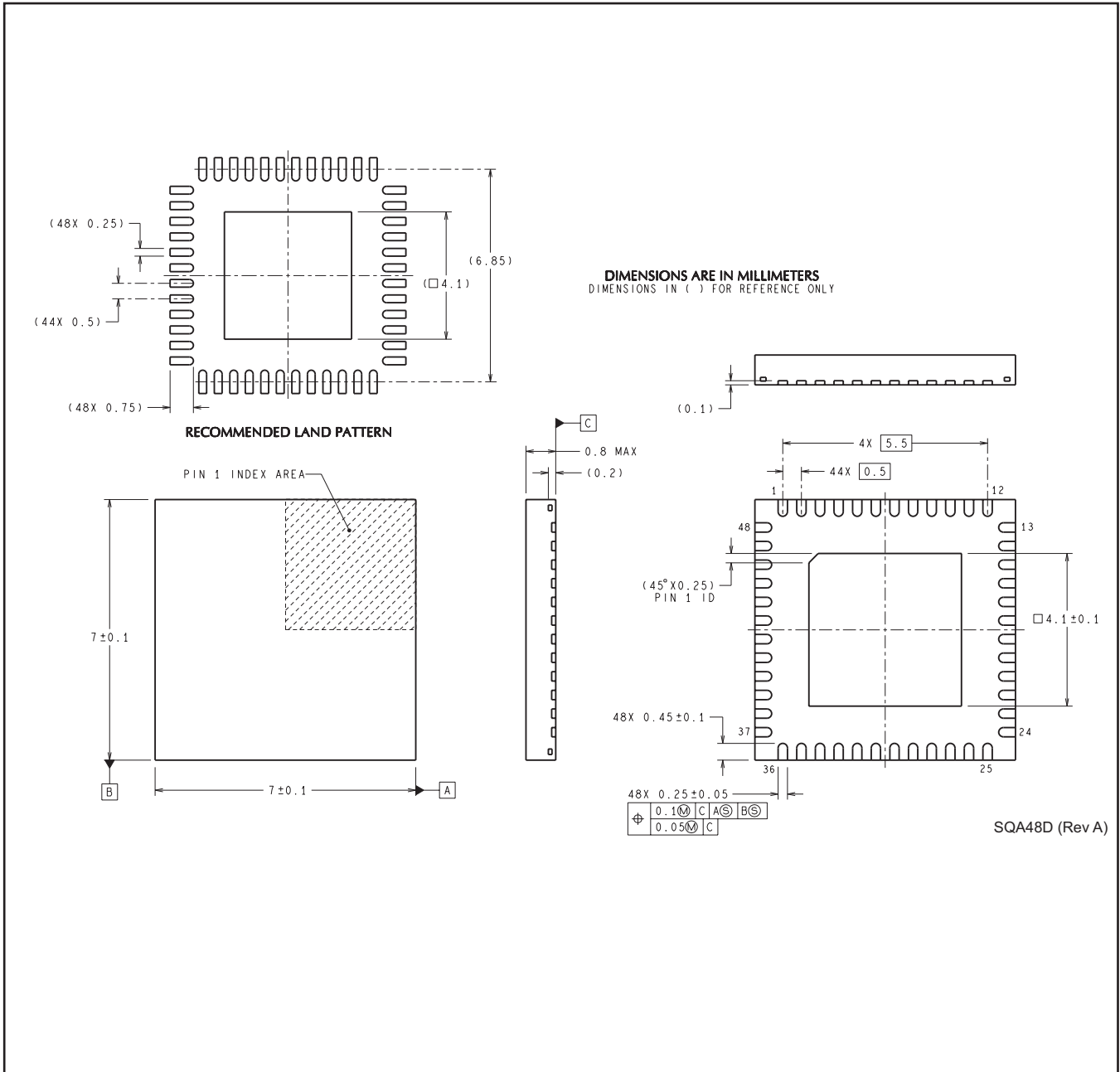

SQA48D (Rev A)

IMPORTANT NOTICE

Texas Instruments Incorporated and its subsidiaries (TI) reserve the right to make corrections, enhancements, improvements and other changes to its semiconductor products and services per JESD46, latest issue, and to discontinue any product or service per JESD48, latest issue. Buyers should obtain the latest relevant information before placing orders and should verify that such information is current and complete. All semiconductor products (also referred to herein as "components") are sold subject to TI's terms and conditions of sale supplied at the time of order acknowledgment.

TI warrants performance of its components to the specifications applicable at the time of sale, in accordance with the warranty in TI's terms and conditions of sale of semiconductor products. Testing and other quality control techniques are used to the extent TI deems necessary to support this warranty. Except where mandated by applicable law, testing of all parameters of each component is not necessarily performed.

TI assumes no liability for applications assistance or the design of Buyers' products. Buyers are responsible for their products and applications using TI components. To minimize the risks associated with Buyers' products and applications, Buyers should provide adequate design and operating safeguards.

TI does not warrant or represent that any license, either express or implied, is granted under any patent right, copyright, mask work right, or other intellectual property right relating to any combination, machine, or process in which TI components or services are used. Information published by TI regarding third-party products or services does not constitute a license to use such products or services or a warranty or endorsement thereof. Use of such information may require a license from a third party under the patents or other intellectual property of the third party, or a license from TI under the patents or other intellectual property of TI.

Reproduction of significant portions of TI information in TI data books or data sheets is permissible only if reproduction is without alteration and is accompanied by all associated warranties, conditions, limitations, and notices. TI is not responsible or liable for such altered documentation. Information of third parties may be subject to additional restrictions.

Resale of TI components or services with statements different from or beyond the parameters stated by TI for that component or service voids all express and any implied warranties for the associated TI component or service and is an unfair and deceptive business practice. TI is not responsible or liable for any such statements.

Buyer acknowledges and agrees that it is solely responsible for compliance with all legal, regulatory and safety-related requirements concerning its products, and any use of TI components in its applications, notwithstanding any applications-related information or support that may be provided by TI. Buyer represents and agrees that it has all the necessary expertise to create and implement safeguards which anticipate dangerous consequences of failures, monitor failures and their consequences, lessen the likelihood of failures that might cause harm and take appropriate remedial actions. Buyer will fully indemnify TI and its representatives against any damages arising out of the use of any TI components in safety-critical applications.

In some cases, TI components may be promoted specifically to facilitate safety-related applications. With such components, TI's goal is to help enable customers to design and create their own end-product solutions that meet applicable functional safety standards and requirements. Nonetheless, such components are subject to these terms.

No TI components are authorized for use in FDA Class III (or similar life-critical medical equipment) unless authorized officers of the parties have executed a special agreement specifically governing such use.

Only those TI components which TI has specifically designated as military grade or "enhanced plastic" are designed and intended for use in military/aerospace applications or environments. Buyer acknowledges and agrees that any military or aerospace use of TI components which have **not** been so designated is solely at the Buyer's risk, and that Buyer is solely responsible for compliance with all legal and regulatory requirements in connection with such use.

TI has specifically designated certain components as meeting ISO/TS16949 requirements, mainly for automotive use. In any case of use of non-designated products, TI will not be responsible for any failure to meet ISO/TS16949.

Products

Audio	www.ti.com/audio
Amplifiers	amplifier.ti.com
Data Converters	dataconverter.ti.com
DLP® Products	www.dlp.com
DSP	dsp.ti.com
Clocks and Timers	www.ti.com/clocks
Interface	interface.ti.com
Logic	logic.ti.com
Power Mgmt	power.ti.com
Microcontrollers	microcontroller.ti.com
RFID	www.ti-rfid.com
OMAP Applications Processors	www.ti.com/omap
Wireless Connectivity	www.ti.com/wirelessconnectivity

Applications

Automotive and Transportation	www.ti.com/automotive
Communications and Telecom	www.ti.com/communications
Computers and Peripherals	www.ti.com/computers
Consumer Electronics	www.ti.com/consumer-apps
Energy and Lighting	www.ti.com/energy
Industrial	www.ti.com/industrial
Medical	www.ti.com/medical
Security	www.ti.com/security
Space, Avionics and Defense	www.ti.com/space-avionics-defense
Video and Imaging	www.ti.com/video

TI E2E Community

e2e.ti.com