

DRV5023 Digital-Switch Hall Effect Sensor

1 Features

- Digital Unipolar-Switch Hall Sensor
- Superior Temperature Stability
 - Sensitivity $\pm 10\%$ Over Temperature
- Multiple Sensitivity Options (B_{OP} / B_{RP}):
 - 3.5 / 2 mT (FA, see [Figure 23](#))
 - 6.9 / 3.2 mT (AJ, see [Figure 23](#))
 - 14.5 / 6 mT (BI, see [Figure 23](#))
- Supports a Wide Voltage Range
 - 2.5 to 38 V
 - No External Regulator Required
- Wide Operating Temperature Range
 - $T_A = -40$ to 125°C (Q, see [Figure 23](#))
- Open Drain Output (30-mA Sink)
- Fast 35- μs Power-On Time
- Small Package and Footprint
 - Surface Mount 3-Pin SOT-23 (DBZ)
 - 2.92 mm \times 2.37 mm
 - Through-Hole 3-Pin TO-92 (LPG)
 - 4.00 mm \times 3.15 mm
- **Protection Features**
 - Reverse Supply Protection (up to -22 V)
 - Supports up to 40-V Load Dump
 - Output Short-Circuit Protection
 - Output Current Limitation

2 Applications

- Docking Detection
- Door Open and Close Detection
- Proximity Sensing
- Valve Positioning
- Pulse Counting

3 Description

The DRV5023 device is a chopper-stabilized Hall Effect Sensor that offers a magnetic sensing solution with superior sensitivity stability over temperature and integrated protection features.

When the applied magnetic flux density exceeds the B_{OP} threshold, the DRV5023 open-drain output goes low. The output stays low until the field decreases to less than B_{RP} , and then the output goes to high impedance. The output current sink capability is 30 mA. A wide operating voltage range from 2.5 to 38 V with reverse polarity protection up to -22 V makes the device suitable for a wide range of industrial applications.

Internal protection functions are provided for reverse supply conditions, load dump, and output short circuit or over current.

Device Information⁽¹⁾

PART NUMBER	PACKAGE	BODY SIZE (NOM)
DRV5023	SOT-23 (3)	2.92 mm \times 1.30 mm
	TO-92 (3)	4.00 mm \times 3.15 mm

(1) For all available packages, see the orderable addendum at the end of the data sheet.

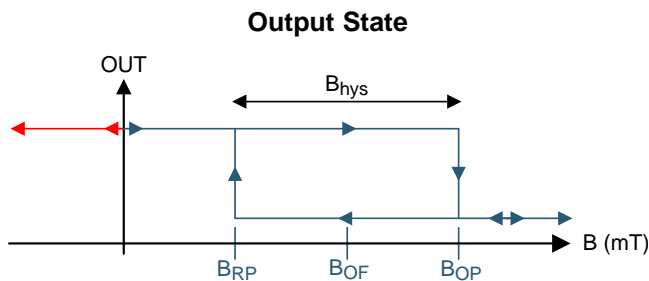

SOT-23

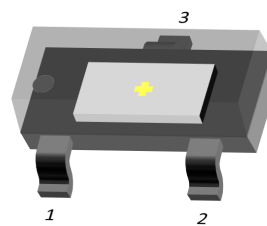

TO-92

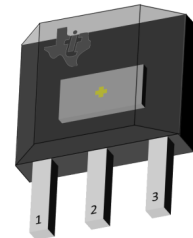

Table of Contents

1 Features	1	7.1 Overview	9
2 Applications	1	7.2 Functional Block Diagram	9
3 Description	1	7.3 Feature Description	10
4 Revision History	2	7.4 Device Functional Modes	15
5 Pin Configuration and Functions	4	8 Application and Implementation	16
6 Specifications	5	8.1 Application Information	16
6.1 Absolute Maximum Ratings	5	8.2 Typical Applications	16
6.2 ESD Ratings	5	9 Power Supply Recommendations	18
6.3 Recommended Operating Conditions	5	10 Device and Documentation Support	19
6.4 Thermal Information	5	10.1 Device Support	19
6.5 Electrical Characteristics	6	10.2 Community Resources	20
6.6 Switching Characteristics	6	10.3 Trademarks	20
6.7 Magnetic Characteristics	6	10.4 Electrostatic Discharge Caution	20
6.8 Typical Characteristics	7	10.5 Glossary	20
7 Detailed Description	9	11 Mechanical, Packaging, and Orderable Information	20

4 Revision History

NOTE: Page numbers for previous revisions may differ from page numbers in the current version.

Changes from Revision D (December 2015) to Revision E Page

• Added the FA device option	1
• Added the typical bandwidth value to the <i>Magnetic Characteristics</i> table	6

Changes from Revision C (May 2015) to Revision D Page

• Corrected body size of SOT-23 package and SIP package name to TO-92	1
• Added B _{MAX} to <i>Absolute Maximum Ratings</i>	5
• Removed table note from junction temperature	5
• Updated package tape and reel options for M and blank	19
• Added Community Resources	20

Changes from Revision B (September 2014) to Revision C Page

• Updated device status to production data	1
--	----------

Changes from Revision A (August 2014) to Revision B Page

• Updated High Sensitivity Options to +6.9 / +3.2 mT (AJ) and +14.5 / +6 mT (BI)	1
• Added typical rise and fall time and removed maximum value	6
• Updated the device values and typical values in <i>Magnetic Characteristics</i>	6
• Updated all <i>Typical Characteristics</i> graphs	7
• Updated Equation 4	17
• Updated Figure 23	19

Changes from Original (May 2014) to Revision A	Page
• Changed High Sensitivity Options: +6.9 / +2.3 mT (AJ) to +6.9 / +3.3 mT (AJ)	1
• Changed the maximum T_J value from 175°C to 150°C	5
• Changed MIN value for I_{OCP} from 20 to 15	6
• Changed Max value for I_{OCP} from 40 to 45	6
• Updated <i>Magnetic Characteristics</i> table.	6

5 Pin Configuration and Functions

For additional configuration information, see [Device Markings](#) and [Mechanical, Packaging, and Orderable Information](#).

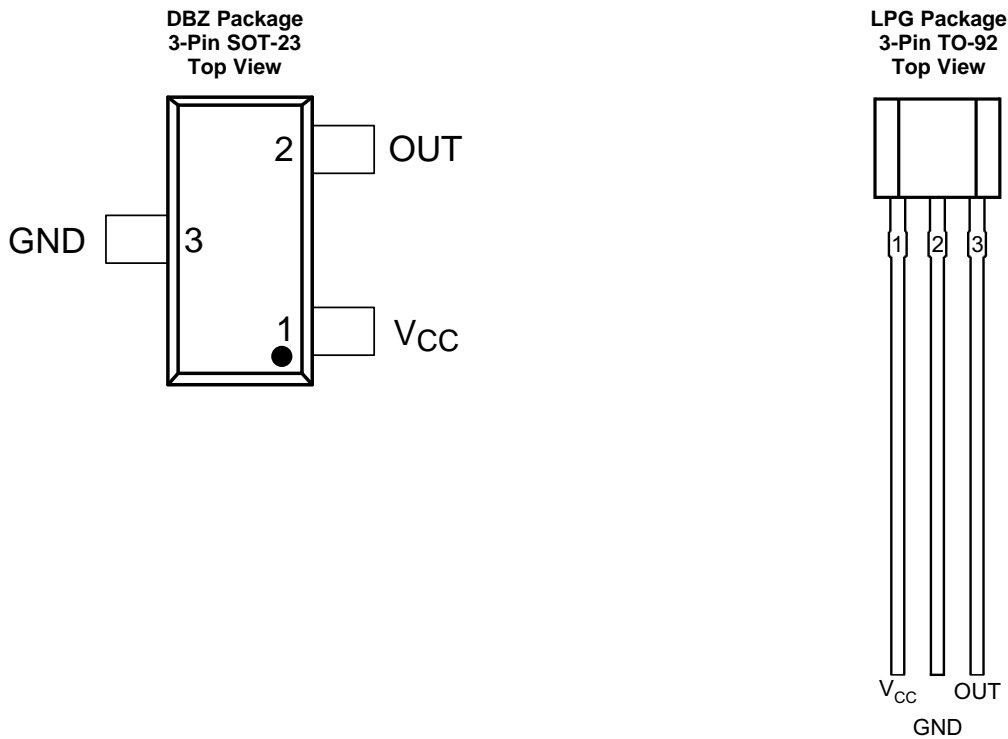

Pin Functions

NAME	PIN		TYPE	DESCRIPTION
	DBZ	LPG		
GND	3	2	GND	Ground pin
OUT	2	3	Output	Hall sensor open-drain output. The open drain requires a resistor pullup.
V _{CC}	1	1	Power	2.5 to 38 V power supply. Bypass this pin to the GND pin with a 0.01- μ F (minimum) ceramic capacitor rated for V _{CC} .

6 Specifications

6.1 Absolute Maximum Ratings

over operating free-air temperature range (unless otherwise noted)⁽¹⁾

		MIN	MAX	UNIT
Power supply voltage	V _{CC}	-22 ⁽²⁾	40	V
	Voltage ramp rate (V _{CC}), V _{CC} < 5 V	Unlimited		V/μs
	Voltage ramp rate (V _{CC}), V _{CC} > 5 V	0	2	
Output pin voltage		-0.5	40	V
Output pin reverse current during reverse supply condition		0	100	mA
Magnetic flux density, B _{MAX}		Unlimited		
Operating junction temperature, T _J		-40	150	°C
Storage temperature, T _{stg}		-65	150	°C

- (1) Stresses beyond those listed under *Absolute Maximum Ratings* may cause permanent damage to the device. These are stress ratings only, which do not imply functional operation of the device at these or any other conditions beyond those indicated under *Recommended Operating Conditions*. Exposure to absolute-maximum-rated conditions for extended periods may affect device reliability.
- (2) Ensured by design. Only tested to -20 V.

6.2 ESD Ratings

		VALUE	UNIT
V _(ESD)	Electrostatic discharge	Human body model (HBM), per ANSI/ESDA/JEDEC JS-001, all pins ⁽¹⁾	±2500
		Charged device model (CDM), per JEDEC specification JESD22-C101, all pins ⁽²⁾	±500

- (1) JEDEC document JEP155 states that 500-V HBM allows safe manufacturing with a standard ESD control process.
- (2) JEDEC document JEP157 states that 250-V CDM allows safe manufacturing with a standard ESD control process.

6.3 Recommended Operating Conditions

over operating free-air temperature range (unless otherwise noted)

		MIN	MAX	UNIT
V _{CC}	Power supply voltage	2.5	38	V
V _O	Output pin voltage (OUT)	0	38	V
I _{SINK}	Output pin current sink (OUT) ⁽¹⁾	0	30	mA
T _A	Operating ambient temperature	-40	125	°C

- (1) Power dissipation and thermal limits must be observed.

6.4 Thermal Information

THERMAL METRIC ⁽¹⁾	DRV5023		UNIT	
	DBZ (SOT-23)	LPG (TO-92)		
	3 PINS	3 PINS		
R _{θJA}	Junction-to-ambient thermal resistance	333.2	180	°C/W
R _{θJC(top)}	Junction-to-case (top) thermal resistance	99.9	98.6	°C/W
R _{θJB}	Junction-to-board thermal resistance	66.9	154.9	°C/W
ψ _{JT}	Junction-to-top characterization parameter	4.9	40	°C/W
ψ _{JB}	Junction-to-board characterization parameter	65.2	154.9	°C/W

- (1) For more information about traditional and new thermal metrics, see the *Semiconductor and IC Package Thermal Metrics* application report, [SPRA953](#).

6.5 Electrical Characteristics

over operating free-air temperature range (unless otherwise noted)

PARAMETER		TEST CONDITIONS	MIN	TYP	MAX	UNIT
POWER SUPPLIES (V_{CC})						
V _{CC}	V _{CC} operating voltage		2.5		38	V
I _{CC}	Operating supply current	V _{CC} = 2.5 to 38 V, T _A = 25°C		2.7		mA
		V _{CC} = 2.5 to 38 V, T _A = 125°C		3	3.5	
t _{on}	Power-on time			35	50	µs
OPEN DRAIN OUTPUT (OUT)						
r _{DS(on)}	FET on-resistance	V _{CC} = 3.3 V, I _O = 10 mA, T _A = 25°C		22		Ω
		V _{CC} = 3.3 V, I _O = 10 mA, T _A = 125°C		36	50	
I _{lkg(off)}	Off-state leakage current	Output Hi-Z			1	µA
PROTECTION CIRCUITS						
V _{CCR}	Reverse supply voltage		-22			V
I _{OCP}	Overcurrent protection level	OUT shorted V _{CC}	15	30	45	mA

6.6 Switching Characteristics

over operating free-air temperature range (unless otherwise noted)

PARAMETER		TEST CONDITIONS	MIN	TYP	MAX	UNIT
OPEN DRAIN OUTPUT (OUT)						
t _d	Output delay time	B = B _{RP} – 10 mT to B _{OP} + 10 mT in 1 µs		13	25	µs
t _r	Output rise time (10% to 90%)	R1 = 1 kΩ, C _O = 50 pF, V _{CC} = 3.3 V		200		ns
t _f	Output fall time (90% to 10%)	R1 = 1 kΩ, C _O = 50 pF, V _{CC} = 3.3 V		31		ns

6.7 Magnetic Characteristics

over operating free-air temperature range (unless otherwise noted)

PARAMETER		TEST CONDITIONS	MIN	TYP	MAX	UNIT ⁽¹⁾
f _{BW}	Bandwidth ⁽²⁾		20	30		kHz
DRV5023FA: 3.5 / 2 mT						
B _{OP}	Operate point (see Figure 12)	T _A = –40°C to 125°C	1.5	3.5	6	mT
B _{RP}	Release point (see Figure 12)		0.5	2	4	mT
B _{hys}	Hysteresis; B _{hys} = (B _{OP} – B _{RP})			1.5		mT
B _O	Magnetic offset, B _O = (B _{OP} + B _{RP}) / 2			2.7		mT
DRV5023AJ: 6.9 / 3.2 mT						
B _{OP}	Operate point (see Figure 12)	T _A = –40°C to 125°C	3	6.9	12	mT
B _{RP}	Release point (see Figure 12)		1	3.2	5	mT
B _{hys}	Hysteresis; B _{hys} = (B _{OP} – B _{RP})			3.7		mT
B _O	Magnetic offset, B _O = (B _{OP} + B _{RP}) / 2			5		mT
DRV5023BI: 14.5 / 6 mT						
B _{OP}	Operate point (see Figure 12)	T _A = –40°C to 125°C	6	14.5	24	mT
B _{RP}	Release point (see Figure 12)		3	6	9	mT
B _{hys}	Hysteresis; B _{hys} = (B _{OP} – B _{RP}) ⁽³⁾			8.5		mT
B _O	Magnetic offset, B _O = (B _{OP} + B _{RP}) / 2			10.3		mT

(1) 1 mT = 10 Gauss

(2) Bandwidth describes the fastest changing magnetic field that can be detected and translated to the output.

 (3) |B_{OP}| is always greater than |B_{RP}|.

6.8 Typical Characteristics

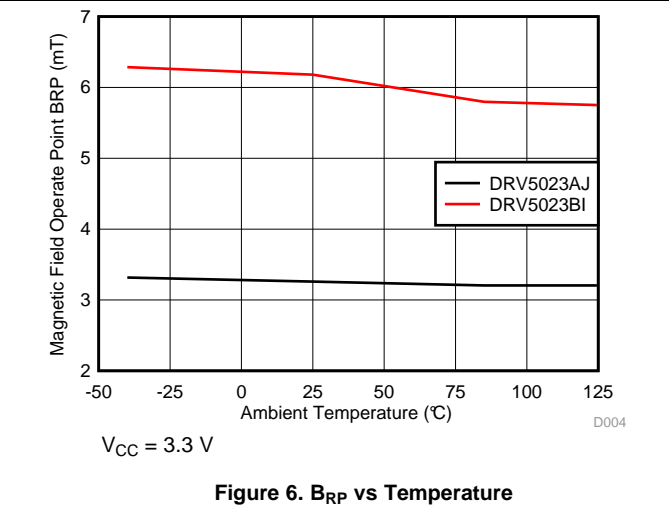
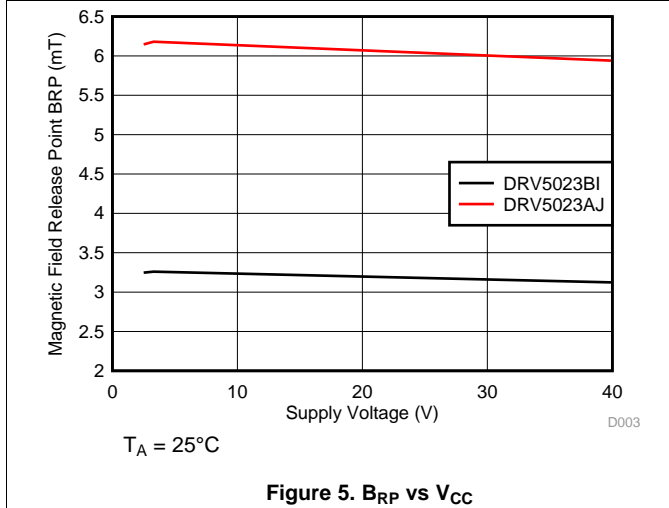
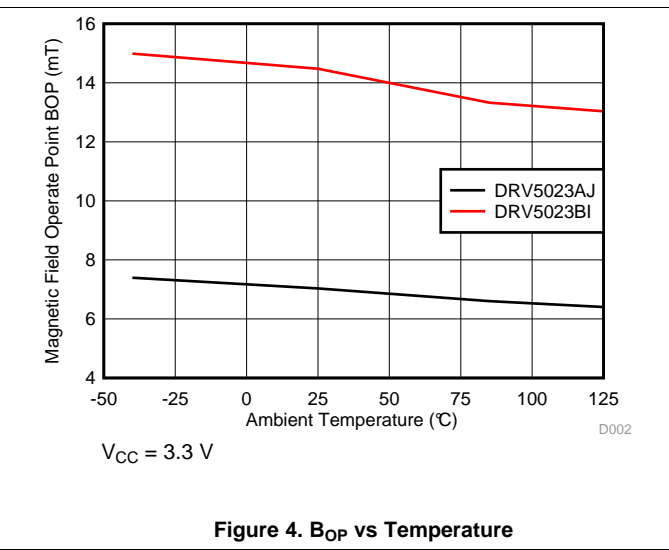
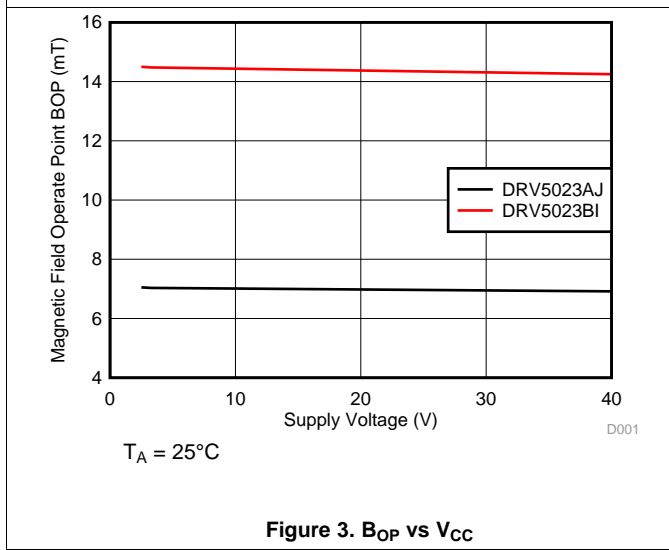
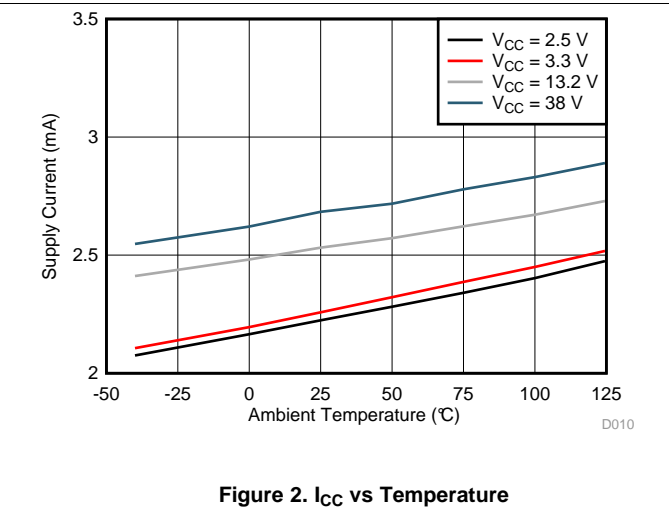
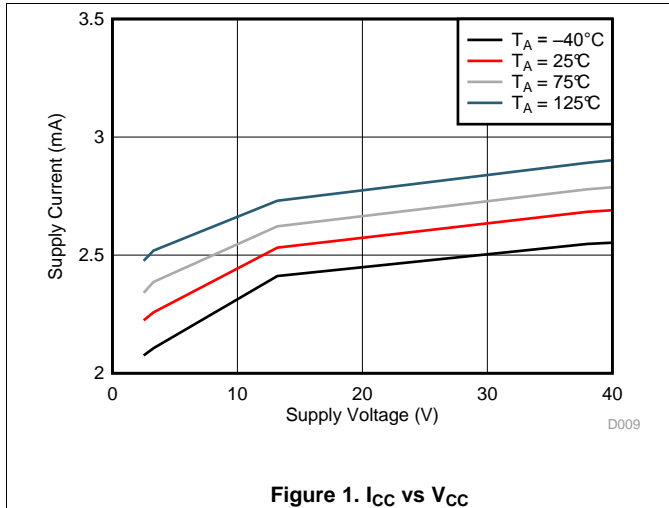

Typical Characteristics (continued)

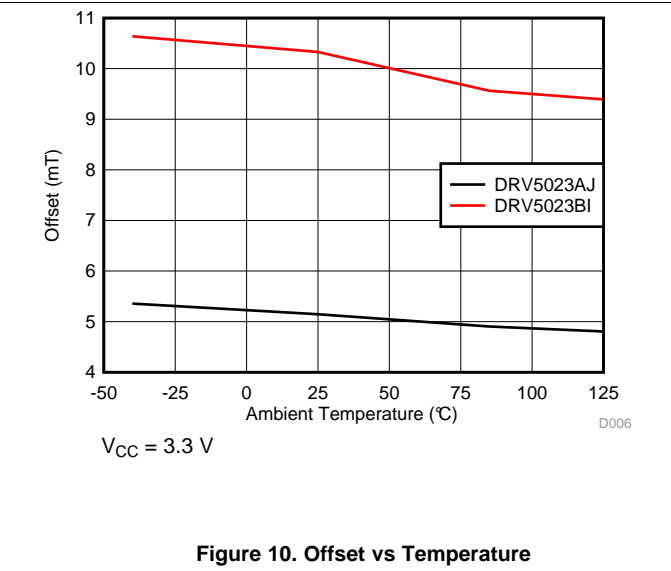
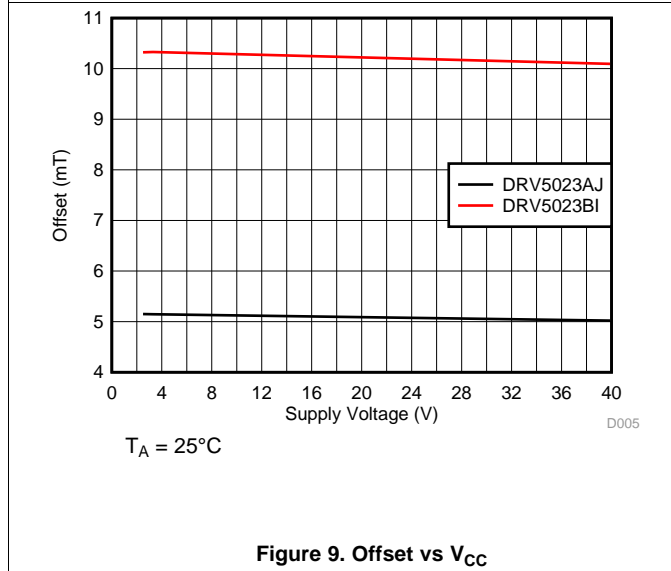
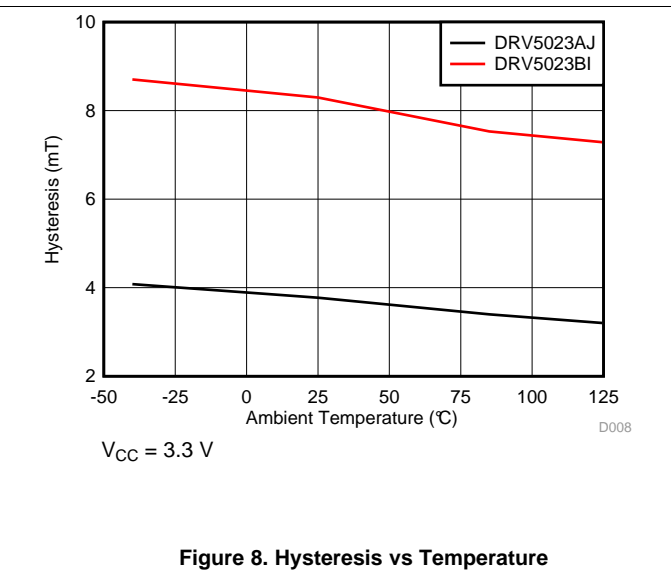
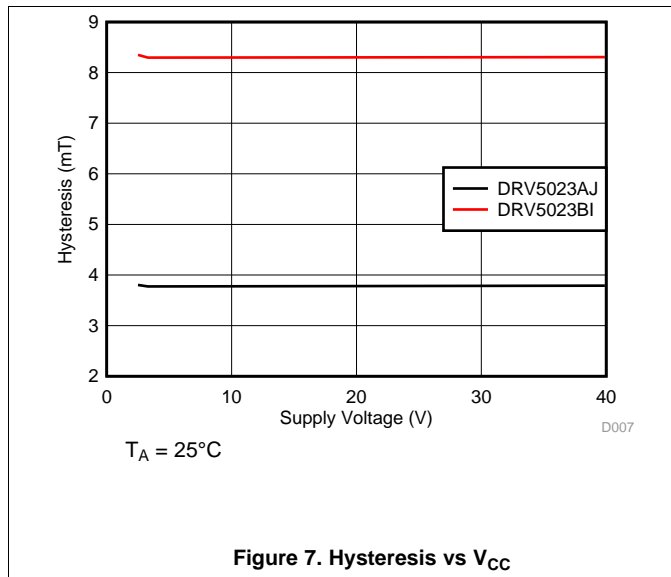

7 Detailed Description

7.1 Overview

The DRV5023 device is a chopper-stabilized Hall sensor with a digital output for magnetic sensing applications. The DRV5023 device can be powered with a supply voltage between 2.5 and 38 V, and will survive -22 V reverse-battery conditions. The DRV5023 device does not operate when -22 to 2.4 V is applied to the V_{CC} pin (with respect to GND pin). In addition, the device can withstand supply voltages up to 40 V for transient durations.

The field polarity is defined as follows: a **south pole** near the marked side of the package is a positive magnetic field. A **north pole** near the marked side of the package is a negative magnetic field.

The output state is dependent on the magnetic field perpendicular to the package. A strong **south pole** near the marked side of the package causes the output to pull low (operate point, BOP), and a weak **south pole** causes the output to release (release point, BRP). Hysteresis is included in between the operate point and the release point therefore magnetic-field noise does not accidentally trip the output.

An external pullup resistor is required on the OUT pin. The OUT pin can be pulled up to V_{CC} , or to a different voltage supply. This allows for easier interfacing with controller circuits.

7.2 Functional Block Diagram

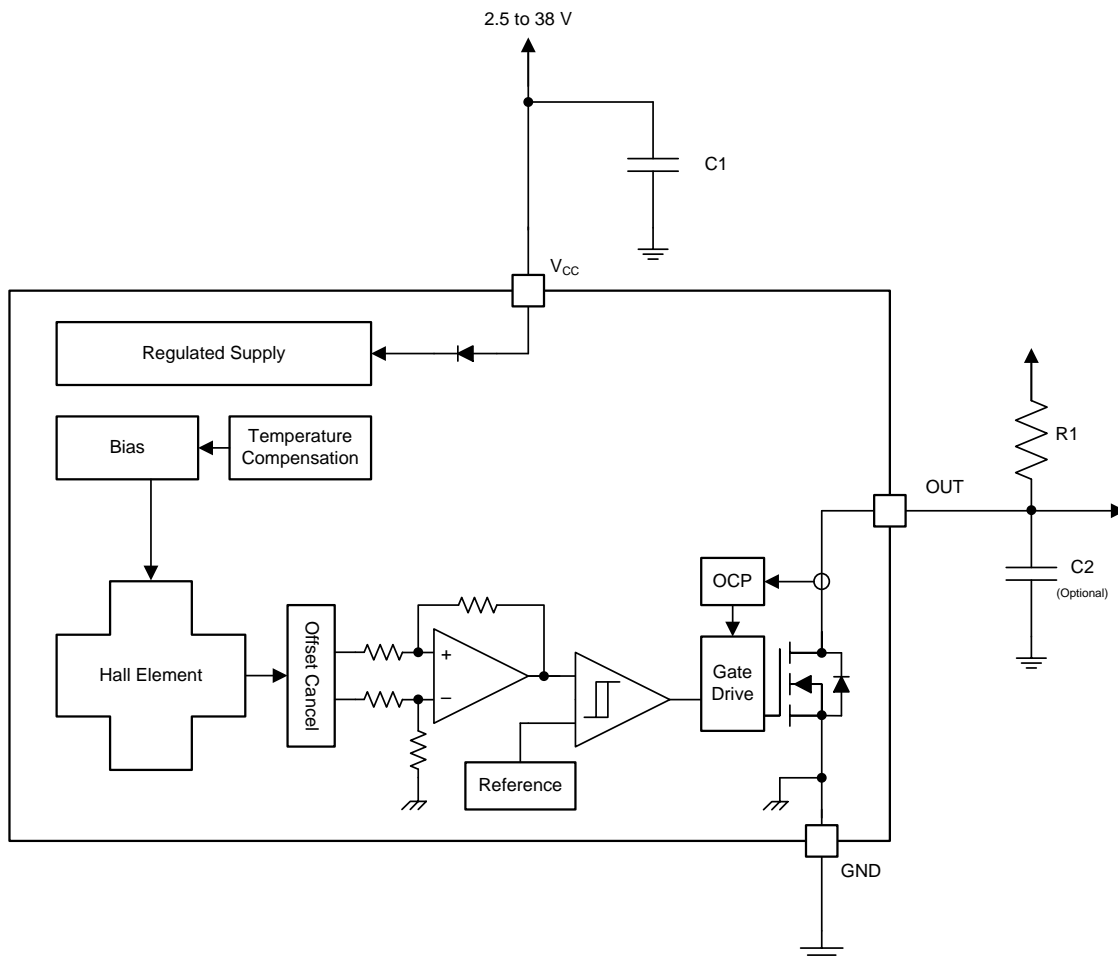

7.3 Feature Description

7.3.1 Field Direction Definition

A positive magnetic field is defined as a **south pole** near the marked side of the package as shown in [Figure 11](#).

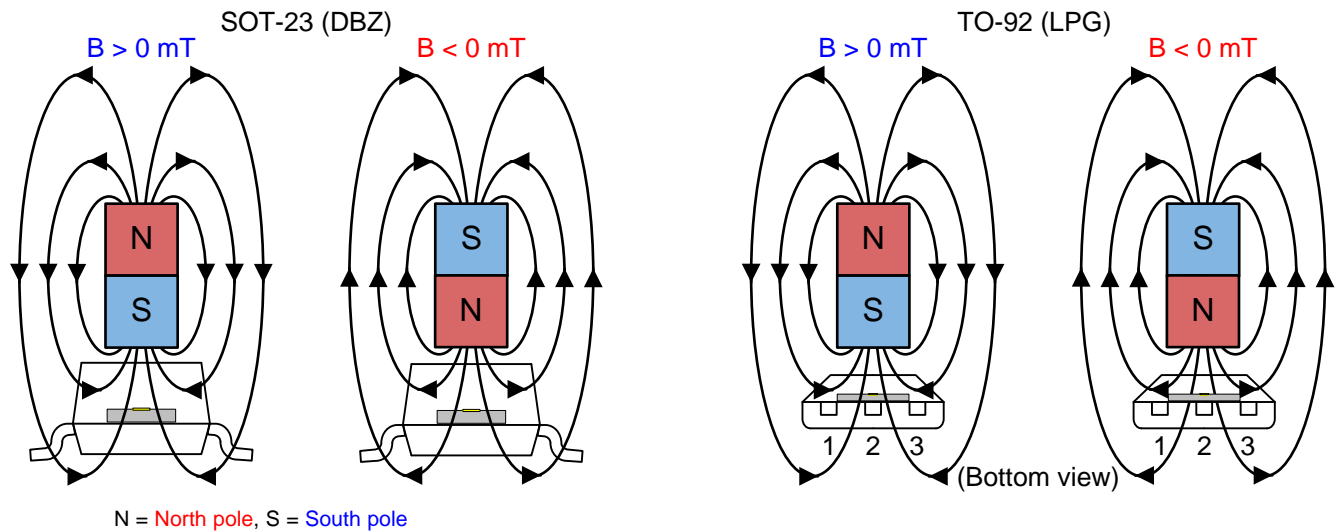

Figure 11. Field Direction Definition

7.3.2 Device Output

If the device is powered on with a magnetic field strength between B_{RP} and B_{OP} , then the device output is indeterminate and can either be Hi-Z or Low. If the field strength is greater than B_{OP} , then the output is pulled low. If the field strength is less than B_{RP} , then the output is released.

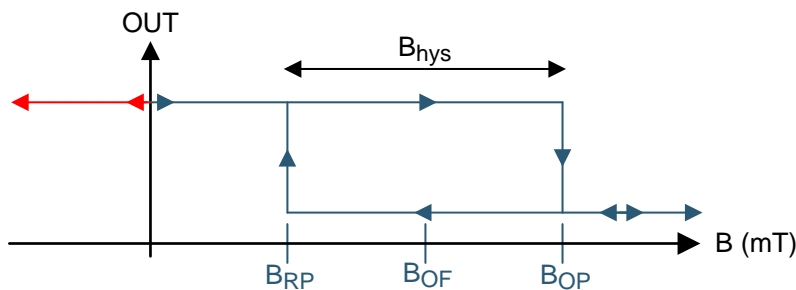

Figure 12. Output State

Feature Description (continued)

7.3.3 Power-On Time

After applying V_{CC} to the DRV5023 device, t_{on} must elapse before the OUT pin is valid. During the power-up sequence, the output is Hi-Z. A pulse as shown in Figure 13 and Figure 14 occurs at the end of t_{on} . This pulse can allow the host processor to determine when the DRV5023 output is valid after startup. In Case 1 (Figure 13) and Case 2 (Figure 14), the output is defined assuming a constant magnetic field $B > B_{OP}$ and $B < B_{RP}$.

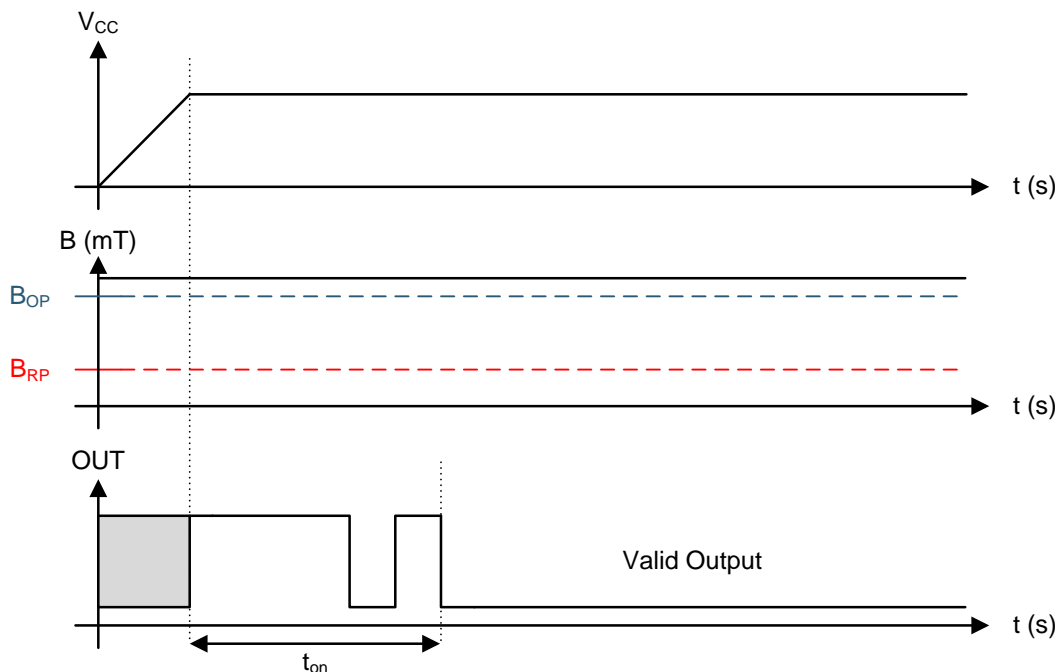

Figure 13. Case 1: Power On When $B > B_{OP}$

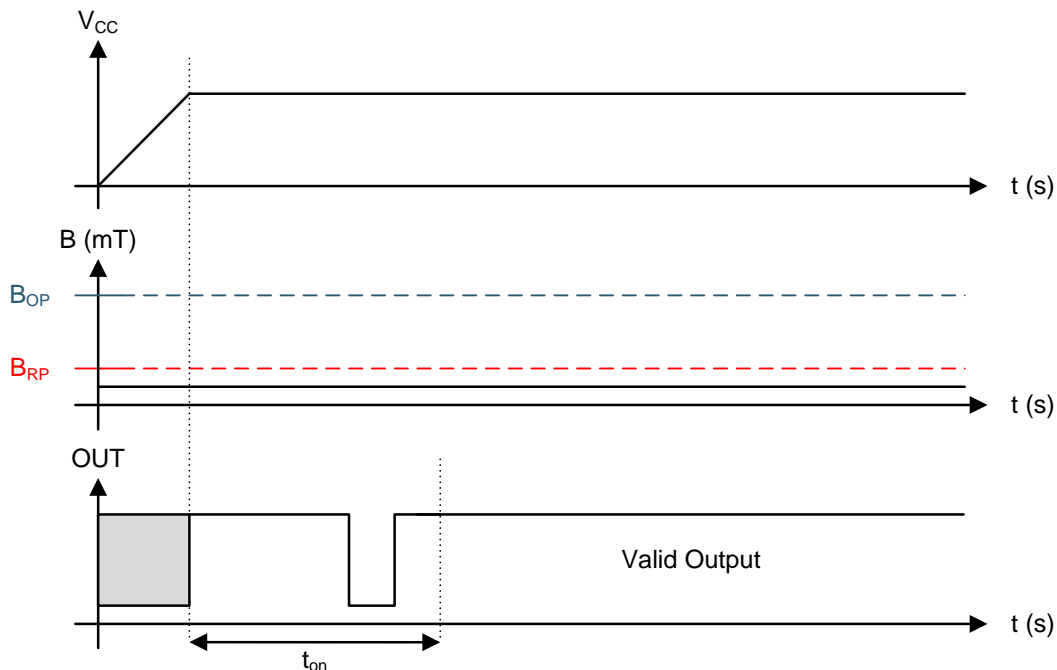

Figure 14. Case 2: Power On When $B < B_{RP}$

Feature Description (continued)

If the device is powered on with the magnetic field strength $B_{RP} < B < B_{OP}$, then the device output is indeterminate and can either be Hi-Z or pulled low. During the power-up sequence, the output is held Hi-Z until t_{on} has elapsed. At the end of t_{on} , a pulse is given on the OUT pin to indicate that t_{on} has elapsed. After t_{on} , if the magnetic field changes such that $B_{OP} < B$, the output is released. Case 3 (Figure 15) and Case 4 (Figure 16) show examples of this behavior.

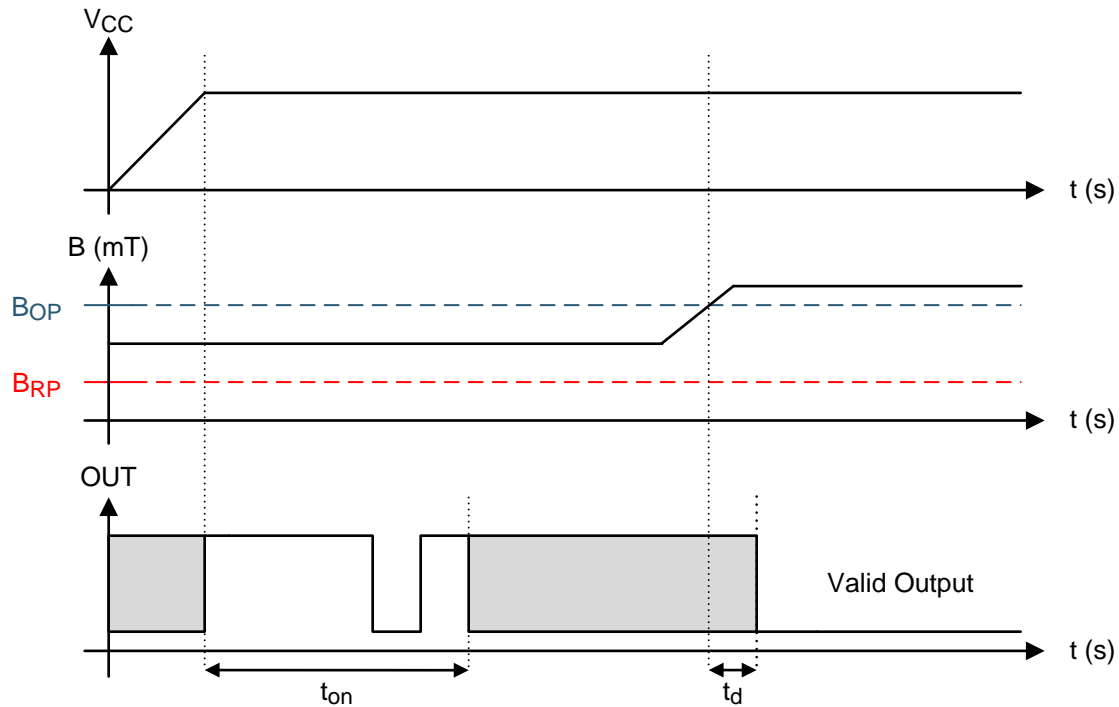

Figure 15. Case 3: Power On When $B_{RP} < B < B_{OP}$, Followed by $B > B_{OP}$

Feature Description (continued)

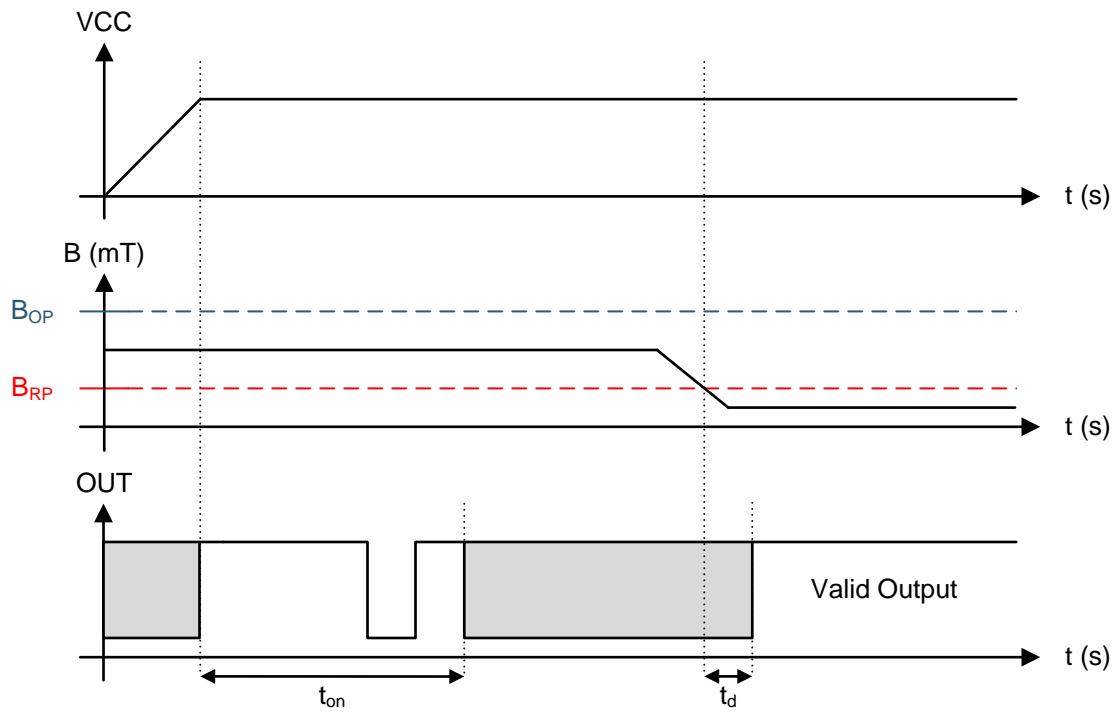

Figure 16. Case 4: Power On When $B_{RP} < B < B_{OP}$, Followed by $B < B_{RP}$

Feature Description (continued)

7.3.4 Output Stage

The DRV5023 output stage uses an open-drain NMOS, and it is rated to sink up to 30 mA of current. For proper operation, calculate the value of the pullup resistor R1 using [Equation 1](#).

$$\frac{V_{\text{ref max}}}{30 \text{ mA}} \leq R1 \leq \frac{V_{\text{ref min}}}{100 \mu\text{A}} \quad (1)$$

The size of R1 is a tradeoff between the OUT rise time and the current when OUT is pulled low. A lower current is generally better, however faster transitions and bandwidth require a smaller resistor for faster switching.

In addition, ensure that the value of R1 > 500 Ω to ensure the output driver can pull the OUT pin close to GND.

NOTE

V_{ref} is not restricted to V_{CC} . The allowable voltage range of this pin is specified in the [Absolute Maximum Ratings](#).

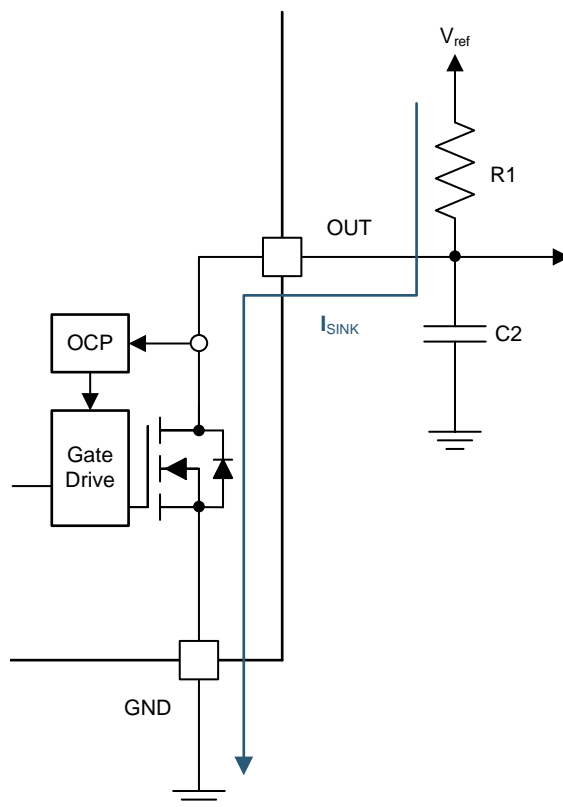

Figure 17.

Select a value for C2 based on the system bandwidth specifications as shown in [Equation 2](#).

$$2 \times f_{\text{BW}} \text{ (Hz)} < \frac{1}{2\pi \times R1 \times C2} \quad (2)$$

Most applications do not require this C2 filtering capacitor.

Feature Description (continued)

7.3.5 Protection Circuits

The DRV5023 device is fully protected against overcurrent and reverse-supply conditions.

7.3.5.1 Overcurrent Protection (OCP)

An analog current-limit circuit limits the current through the FET. The driver current is clamped to I_{OCP} . During this clamping, the $r_{DS(on)}$ of the output FET is increased from the nominal value.

7.3.5.2 Load Dump Protection

The DRV5023 device operates at DC V_{CC} conditions up to 38 V nominally, and can additionally withstand $V_{CC} = 40$ V. No current-limiting series resistor is required for this protection.

7.3.5.3 Reverse Supply Protection

The DRV5023 device is protected in the event that the V_{CC} pin and the GND pin are reversed (up to -22 V).

NOTE

In a reverse supply condition, the OUT pin reverse-current must not exceed the ratings specified in the [Absolute Maximum Ratings](#).

Table 1.

FAULT	CONDITION	DEVICE	DESCRIPTION	RECOVERY
FET overload (OCP)	$I_{SINK} \geq I_{OCP}$	Operating	Output current is clamped to I_{OCP}	$I_O < I_{OCP}$
Load dump	$38\text{ V} < V_{CC} < 40\text{ V}$	Operating	Device will operate for a transient duration	$V_{CC} \leq 38\text{ V}$
Reverse supply	$-22\text{ V} < V_{CC} < 0\text{ V}$	Disabled	Device will survive this condition	$V_{CC} \geq 2.5\text{ V}$

7.4 Device Functional Modes

The DRV5023 device is active only when V_{CC} is between 2.5 and 38 V.

When a reverse supply condition exists, the device is inactive.

8 Application and Implementation

NOTE

Information in the following applications sections is not part of the TI component specification, and TI does not warrant its accuracy or completeness. TI's customers are responsible for determining suitability of components for their purposes. Customers should validate and test their design implementation to confirm system functionality.

8.1 Application Information

The DRV5023 device is used in magnetic-field sensing applications.

8.2 Typical Applications

8.2.1 Standard Circuit

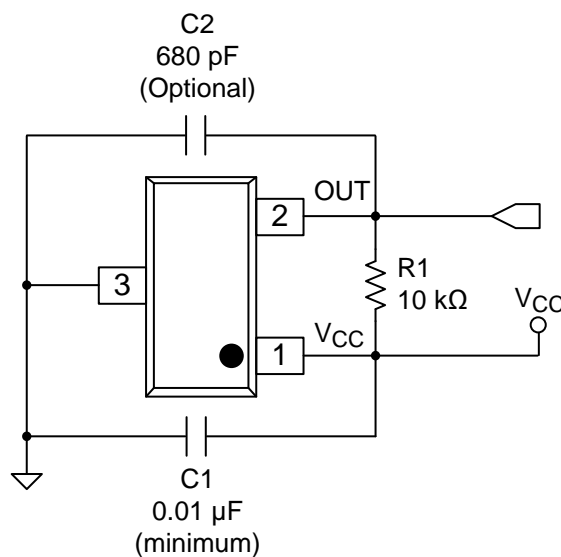

Figure 18. Typical Application Circuit

8.2.1.1 Design Requirements

For this design example, use the parameters listed in Table 2 as the input parameters.

Table 2. Design Parameters

DESIGN PARAMETER	REFERENCE	EXAMPLE VALUE
Supply voltage	V_{CC}	3.2 to 3.4 V
System bandwidth	f_{BW}	10 kHz

8.2.1.2 Detailed Design Procedure

Table 3. External Components

COMPONENT	PIN 1	PIN 2	RECOMMENDED
C1	V_{CC}	GND	A 0.01- μ F (minimum) ceramic capacitor rated for V_{CC}
C2	OUT	GND	Optional: Place a ceramic capacitor to GND
R1	OUT	REF ⁽¹⁾	Requires a resistor pullup

(1) REF is not a pin on the DRV5023 device, but a REF supply-voltage pullup is required for the OUT pin; the OUT pin may be pulled up to V_{CC} .

8.2.1.2.1 Configuration Example

In a 3.3-V system, $3.2\text{ V} \leq V_{\text{ref}} \leq 3.4\text{ V}$. Use Equation 3 to calculate the allowable range for R1.

$$\frac{V_{\text{ref max}}}{30\text{ mA}} \leq R1 \leq \frac{V_{\text{ref min}}}{100\text{ }\mu\text{A}} \tag{3}$$

For this design example, use Equation 4 to calculate the allowable range of R1.

$$\frac{3.4\text{ V}}{30\text{ mA}} \leq R1 \leq \frac{3.2\text{ V}}{100\text{ }\mu\text{A}} \tag{4}$$

Therefore:

$$113\text{ }\Omega \leq R1 \leq 32\text{ k}\Omega \tag{5}$$

After finding the allowable range of R1 (Equation 5), select a value between 500 Ω and 32 k Ω for R1.

Assuming a system bandwidth of 10 kHz, use Equation 6 to calculate the value of C2.

$$2 \times f_{\text{BW}}\text{ (Hz)} < \frac{1}{2\pi \times R1 \times C2} \tag{6}$$

For this design example, use Equation 7 to calculate the value of C2.

$$2 \times 10\text{ kHz} < \frac{1}{2\pi \times R1 \times C2} \tag{7}$$

An R1 value of 10 k Ω and a C2 value less than 820 pF satisfy the requirement for a 10-kHz system bandwidth.

A selection of R1 = 10 k Ω and C2 = 680 pF would cause a low-pass filter with a corner frequency of 23.4 kHz.

8.2.1.3 Application Curves

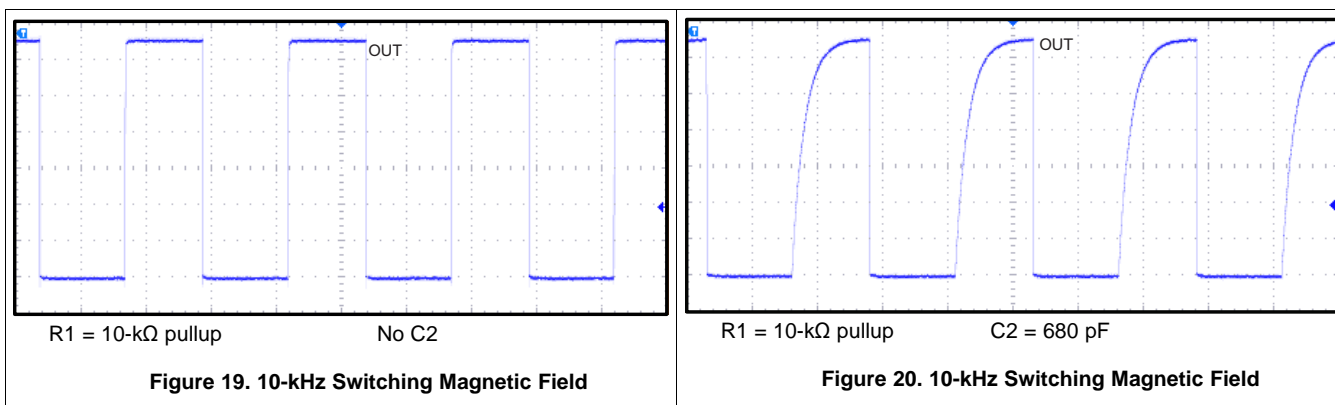

Figure 19. 10-kHz Switching Magnetic Field

Figure 20. 10-kHz Switching Magnetic Field

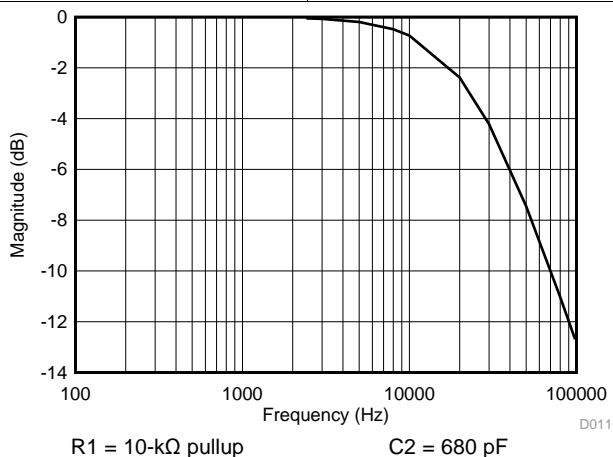

Figure 21. Low-Pass Filtering

8.2.2 Alternative Two-Wire Application

For systems that require minimal wire count, the device output can be connected to V_{CC} through a resistor, and the total supplied current can be sensed near the controller.

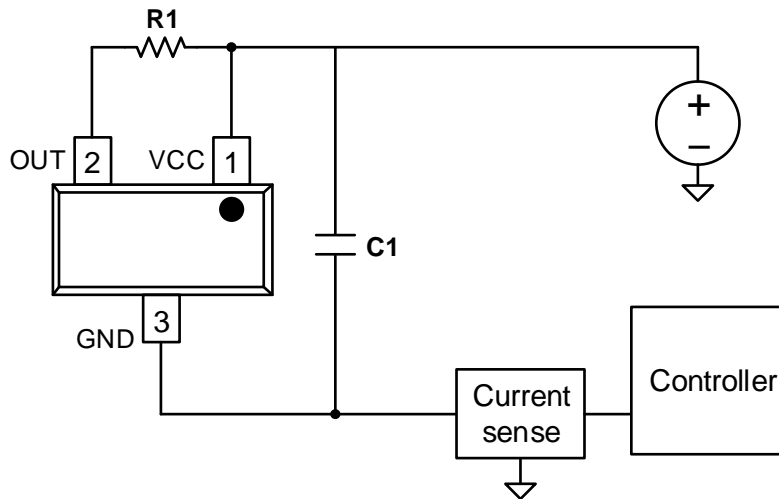

Figure 22. 2-Wire Application

Current can be sensed using a shunt resistor or other circuitry.

8.2.2.1 Design Requirements

Table 4 lists the related design parameters.

Table 4. Design Parameters

DESIGN PARAMETER	REFERENCE	EXAMPLE VALUE
Supply voltage	V_{CC}	12 V
OUT resistor	R1	1 k Ω
Bypass capacitor	C1	0.1 μ F
Current when $B < B_{RP}$	$I_{RELEASE}$	About 3 mA
Current when $B > B_{OP}$	$I_{OPERATE}$	About 15 mA

8.2.2.2 Detailed Design Procedure

When the open-drain output of the device is high-impedance, current through the path equals the I_{CC} of the device (approximately 3 mA).

When the output pulls low, a parallel current path is added, equal to $V_{CC} / (R1 + r_{DS(on)})$. Using 12 V and 1 k Ω , the parallel current is approximately 12 mA, making the total current approximately 15 mA.

The local bypass capacitor C1 should be at least 0.1 μ F, and a larger value if there is high inductance in the power line interconnect.

9 Power Supply Recommendations

The DRV5023 device is designed to operate from an input voltage supply (V_M) range between 2.5 and 38 V. A 0.01- μ F (minimum) ceramic capacitor rated for V_{CC} must be placed as close to the DRV5023 device as possible.

10 Device and Documentation Support

10.1 Device Support

10.1.1 Device Nomenclature

Figure 23 shows a legend for reading the complete device name for and DRV5023 device.

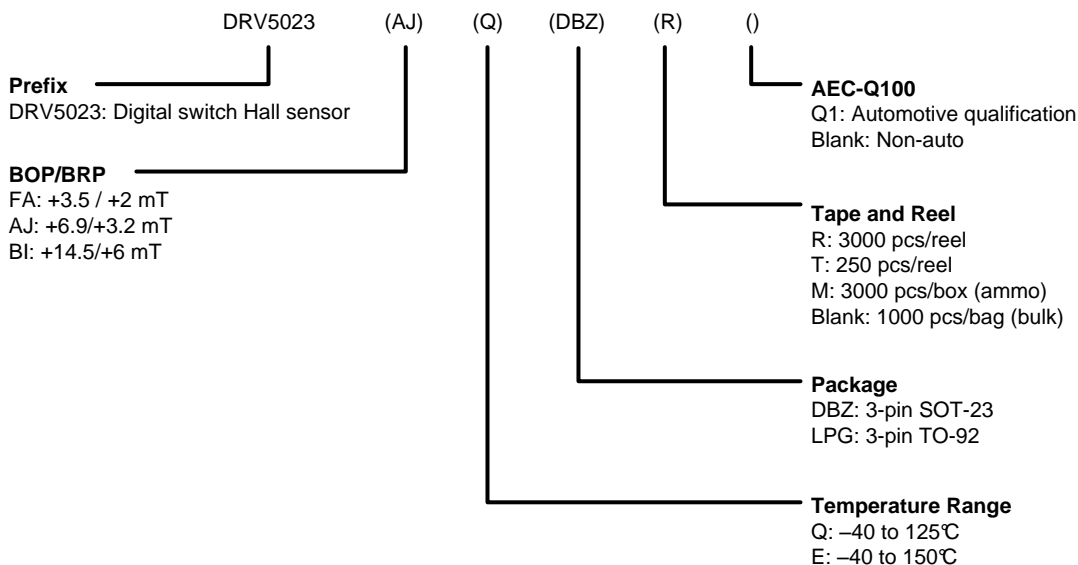

Figure 23. Device Nomenclature

10.1.2 Device Markings

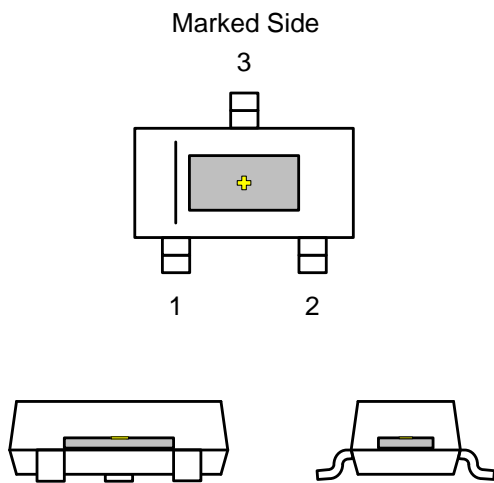

Figure 24. SOT-23 (DBZ) Package

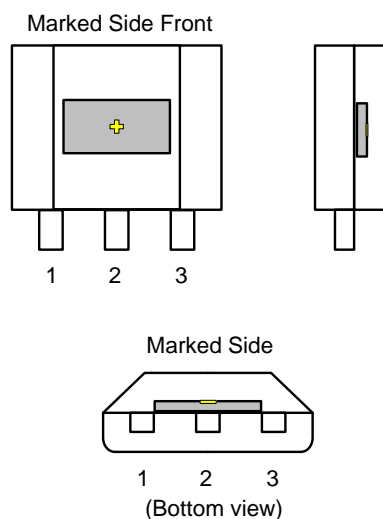

Figure 25. TO-92 (LPG) Package

⊕ indicates the Hall effect sensor (not to scale). The Hall element is located in the center of the package with a tolerance of $\pm 100 \mu\text{m}$. The height of the Hall element from the bottom of the package is $0.7 \text{ mm} \pm 50 \mu\text{m}$ in the DBZ package and $0.987 \text{ mm} \pm 50 \mu\text{m}$ in the LPG package.

10.2 Community Resources

The following links connect to TI community resources. Linked contents are provided "AS IS" by the respective contributors. They do not constitute TI specifications and do not necessarily reflect TI's views; see TI's [Terms of Use](#).

TI E2E™ Online Community *TI's Engineer-to-Engineer (E2E) Community*. Created to foster collaboration among engineers. At e2e.ti.com, you can ask questions, share knowledge, explore ideas and help solve problems with fellow engineers.

Design Support *TI's Design Support* Quickly find helpful E2E forums along with design support tools and contact information for technical support.

10.3 Trademarks

E2E is a trademark of Texas Instruments.
All other trademarks are the property of their respective owners.

10.4 Electrostatic Discharge Caution



These devices have limited built-in ESD protection. The leads should be shorted together or the device placed in conductive foam during storage or handling to prevent electrostatic damage to the MOS gates.

10.5 Glossary

[SLYZ022](#) — *TI Glossary*.

This glossary lists and explains terms, acronyms, and definitions.

11 Mechanical, Packaging, and Orderable Information

The following pages include mechanical, packaging, and orderable information. This information is the most current data available for the designated devices. This data is subject to change without notice and revision of this document. For browser-based versions of this data sheet, refer to the left-hand navigation.

PACKAGING INFORMATION

Orderable Device	Status (1)	Package Type	Package Drawing	Pins	Package Qty	Eco Plan (2)	Lead/Ball Finish (6)	MSL Peak Temp (3)	Op Temp (°C)	Device Marking (4/5)	Samples
DRV5023AJQDBZR	ACTIVE	SOT-23	DBZ	3	3000	Green (RoHS & no Sb/Br)	CU NIPDAU	Level-1-260C-UNLIM	-40 to 125	+PLAJ	Samples
DRV5023AJQDBZT	ACTIVE	SOT-23	DBZ	3	250	Green (RoHS & no Sb/Br)	CU NIPDAU	Level-1-260C-UNLIM	-40 to 125	+PLAJ	Samples
DRV5023AJQLPG	ACTIVE	TO-92	LPG	3	1000	Green (RoHS & no Sb/Br)	CU SN	N / A for Pkg Type	-40 to 125	+PLAJ	Samples
DRV5023AJQLPGM	ACTIVE	TO-92	LPG	3	3000	Green (RoHS & no Sb/Br)	CU SN	N / A for Pkg Type	-40 to 125	+PLAJ	Samples
DRV5023BIQDBZR	ACTIVE	SOT-23	DBZ	3	3000	Green (RoHS & no Sb/Br)	CU NIPDAU	Level-1-260C-UNLIM	-40 to 125	+PLBI	Samples
DRV5023BIQDBZT	ACTIVE	SOT-23	DBZ	3	250	Green (RoHS & no Sb/Br)	CU NIPDAU	Level-1-260C-UNLIM	-40 to 125	+PLBI	Samples
DRV5023BIQLPG	ACTIVE	TO-92	LPG	3	1000	Green (RoHS & no Sb/Br)	CU SN	N / A for Pkg Type	-40 to 125	+PLBI	Samples
DRV5023BIQLPGM	ACTIVE	TO-92	LPG	3	3000	Green (RoHS & no Sb/Br)	CU SN	N / A for Pkg Type	-40 to 125	+PLBI	Samples
DRV5023FAQDBZR	PREVIEW	SOT-23	DBZ	3	3000	Green (RoHS & no Sb/Br)	CU	Level-1-260C-UNLIM	-40 to 125	+PLFA	
PDRV5023FAQDBZR	ACTIVE	SOT-23	DBZ	3	3000	TBD	Call TI	Call TI	-40 to 125		Samples

(1) The marketing status values are defined as follows:

ACTIVE: Product device recommended for new designs.

LIFEBUY: TI has announced that the device will be discontinued, and a lifetime-buy period is in effect.

NRND: Not recommended for new designs. Device is in production to support existing customers, but TI does not recommend using this part in a new design.

PREVIEW: Device has been announced but is not in production. Samples may or may not be available.

OBSOLETE: TI has discontinued the production of the device.

(2) Eco Plan - The planned eco-friendly classification: Pb-Free (RoHS), Pb-Free (RoHS Exempt), or Green (RoHS & no Sb/Br) - please check <http://www.ti.com/productcontent> for the latest availability information and additional product content details.

TBD: The Pb-Free/Green conversion plan has not been defined.

Pb-Free (RoHS): TI's terms "Lead-Free" or "Pb-Free" mean semiconductor products that are compatible with the current RoHS requirements for all 6 substances, including the requirement that lead not exceed 0.1% by weight in homogeneous materials. Where designed to be soldered at high temperatures, TI Pb-Free products are suitable for use in specified lead-free processes.

Pb-Free (RoHS Exempt): This component has a RoHS exemption for either 1) lead-based flip-chip solder bumps used between the die and package, or 2) lead-based die adhesive used between the die and leadframe. The component is otherwise considered Pb-Free (RoHS compatible) as defined above.

Green (RoHS & no Sb/Br): TI defines "Green" to mean Pb-Free (RoHS compatible), and free of Bromine (Br) and Antimony (Sb) based flame retardants (Br or Sb do not exceed 0.1% by weight in homogeneous material)

- (3) MSL, Peak Temp. - The Moisture Sensitivity Level rating according to the JEDEC industry standard classifications, and peak solder temperature.
- (4) There may be additional marking, which relates to the logo, the lot trace code information, or the environmental category on the device.
- (5) Multiple Device Markings will be inside parentheses. Only one Device Marking contained in parentheses and separated by a "~" will appear on a device. If a line is indented then it is a continuation of the previous line and the two combined represent the entire Device Marking for that device.
- (6) Lead/Ball Finish - Orderable Devices may have multiple material finish options. Finish options are separated by a vertical ruled line. Lead/Ball Finish values may wrap to two lines if the finish value exceeds the maximum column width.

Important Information and Disclaimer:The information provided on this page represents TI's knowledge and belief as of the date that it is provided. TI bases its knowledge and belief on information provided by third parties, and makes no representation or warranty as to the accuracy of such information. Efforts are underway to better integrate information from third parties. TI has taken and continues to take reasonable steps to provide representative and accurate information but may not have conducted destructive testing or chemical analysis on incoming materials and chemicals. TI and TI suppliers consider certain information to be proprietary, and thus CAS numbers and other limited information may not be available for release.

In no event shall TI's liability arising out of such information exceed the total purchase price of the TI part(s) at issue in this document sold by TI to Customer on an annual basis.

OTHER QUALIFIED VERSIONS OF DRV5023 :

- Automotive: [DRV5023-Q1](#)

NOTE: Qualified Version Definitions:

- Automotive - Q100 devices qualified for high-reliability automotive applications targeting zero defects

TAPE AND REEL INFORMATION



QUADRANT ASSIGNMENTS FOR PIN 1 ORIENTATION IN TAPE



*All dimensions are nominal

Device	Package Type	Package Drawing	Pins	SPQ	Reel Diameter (mm)	Reel Width W1 (mm)	A0 (mm)	B0 (mm)	K0 (mm)	P1 (mm)	W (mm)	Pin1 Quadrant
DRV5023AJQDBZR	SOT-23	DBZ	3	3000	180.0	8.4	3.15	2.77	1.22	4.0	8.0	Q3
DRV5023AJQDBZT	SOT-23	DBZ	3	250	180.0	8.4	3.15	2.77	1.22	4.0	8.0	Q3
DRV5023BIQDBZR	SOT-23	DBZ	3	3000	180.0	8.4	3.15	2.77	1.22	4.0	8.0	Q3
DRV5023BIQDBZT	SOT-23	DBZ	3	250	180.0	8.4	3.15	2.77	1.22	4.0	8.0	Q3

TAPE AND REEL BOX DIMENSIONS



*All dimensions are nominal

Device	Package Type	Package Drawing	Pins	SPQ	Length (mm)	Width (mm)	Height (mm)
DRV5023AJQDBZR	SOT-23	DBZ	3	3000	202.0	201.0	28.0
DRV5023AJQDBZT	SOT-23	DBZ	3	250	202.0	201.0	28.0
DRV5023BIQDBZR	SOT-23	DBZ	3	3000	202.0	201.0	28.0
DRV5023BIQDBZT	SOT-23	DBZ	3	250	202.0	201.0	28.0

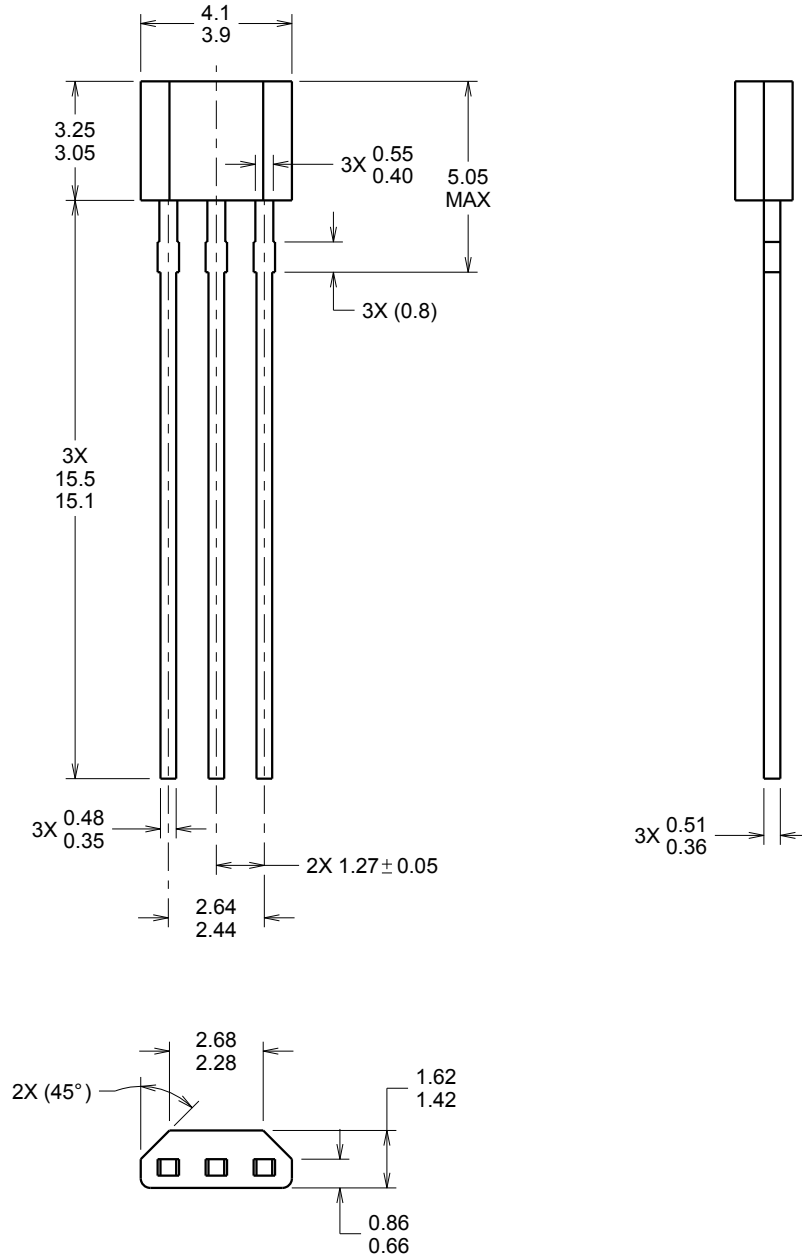
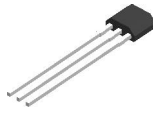

4221343/A 02/2014

NOTES:

1. All linear dimensions are in millimeters. Any dimensions in parenthesis are for reference only. Dimensioning and tolerancing per ASME Y14.5M.
2. This drawing is subject to change without notice.

DBZ (R-PDSO-G3)

PLASTIC SMALL-OUTLINE



- NOTES:
- A. All linear dimensions are in millimeters. Dimensioning and tolerancing per ASME Y14.5M-1994.
 - B. This drawing is subject to change without notice.
 - C. Lead dimensions are inclusive of plating.
 - D. Body dimensions are exclusive of mold flash and protrusion. Mold flash and protrusion not to exceed 0.25 per side.
 - $\triangle E$ Falls within JEDEC TO-236 variation AB, except minimum foot length.

DBZ (R-PDSO-G3)

PLASTIC SMALL OUTLINE



- NOTES:
- A. All linear dimensions are in millimeters.
 - B. This drawing is subject to change without notice.
 - C. Customers should place a note on the circuit board fabrication drawing not to alter the center solder mask defined pad.
 - D. Publication IPC-7351 is recommended for alternate designs.
 - E. Laser cutting apertures with trapezoidal walls and also rounding corners will offer better paste release. Customers should contact their board assembly site for stencil design recommendations. Example stencil design based on a 50% volumetric metal load solder paste. Refer to IPC-7525 for other stencil recommendations.

IMPORTANT NOTICE

Texas Instruments Incorporated and its subsidiaries (TI) reserve the right to make corrections, enhancements, improvements and other changes to its semiconductor products and services per JESD46, latest issue, and to discontinue any product or service per JESD48, latest issue. Buyers should obtain the latest relevant information before placing orders and should verify that such information is current and complete. All semiconductor products (also referred to herein as "components") are sold subject to TI's terms and conditions of sale supplied at the time of order acknowledgment.

TI warrants performance of its components to the specifications applicable at the time of sale, in accordance with the warranty in TI's terms and conditions of sale of semiconductor products. Testing and other quality control techniques are used to the extent TI deems necessary to support this warranty. Except where mandated by applicable law, testing of all parameters of each component is not necessarily performed.

TI assumes no liability for applications assistance or the design of Buyers' products. Buyers are responsible for their products and applications using TI components. To minimize the risks associated with Buyers' products and applications, Buyers should provide adequate design and operating safeguards.

TI does not warrant or represent that any license, either express or implied, is granted under any patent right, copyright, mask work right, or other intellectual property right relating to any combination, machine, or process in which TI components or services are used. Information published by TI regarding third-party products or services does not constitute a license to use such products or services or a warranty or endorsement thereof. Use of such information may require a license from a third party under the patents or other intellectual property of the third party, or a license from TI under the patents or other intellectual property of TI.

Reproduction of significant portions of TI information in TI data books or data sheets is permissible only if reproduction is without alteration and is accompanied by all associated warranties, conditions, limitations, and notices. TI is not responsible or liable for such altered documentation. Information of third parties may be subject to additional restrictions.

Resale of TI components or services with statements different from or beyond the parameters stated by TI for that component or service voids all express and any implied warranties for the associated TI component or service and is an unfair and deceptive business practice. TI is not responsible or liable for any such statements.

Buyer acknowledges and agrees that it is solely responsible for compliance with all legal, regulatory and safety-related requirements concerning its products, and any use of TI components in its applications, notwithstanding any applications-related information or support that may be provided by TI. Buyer represents and agrees that it has all the necessary expertise to create and implement safeguards which anticipate dangerous consequences of failures, monitor failures and their consequences, lessen the likelihood of failures that might cause harm and take appropriate remedial actions. Buyer will fully indemnify TI and its representatives against any damages arising out of the use of any TI components in safety-critical applications.

In some cases, TI components may be promoted specifically to facilitate safety-related applications. With such components, TI's goal is to help enable customers to design and create their own end-product solutions that meet applicable functional safety standards and requirements. Nonetheless, such components are subject to these terms.

No TI components are authorized for use in FDA Class III (or similar life-critical medical equipment) unless authorized officers of the parties have executed a special agreement specifically governing such use.

Only those TI components which TI has specifically designated as military grade or "enhanced plastic" are designed and intended for use in military/aerospace applications or environments. Buyer acknowledges and agrees that any military or aerospace use of TI components which have **not** been so designated is solely at the Buyer's risk, and that Buyer is solely responsible for compliance with all legal and regulatory requirements in connection with such use.

TI has specifically designated certain components as meeting ISO/TS16949 requirements, mainly for automotive use. In any case of use of non-designated products, TI will not be responsible for any failure to meet ISO/TS16949.

Products

Audio	www.ti.com/audio
Amplifiers	amplifier.ti.com
Data Converters	dataconverter.ti.com
DLP® Products	www.dlp.com
DSP	dsp.ti.com
Clocks and Timers	www.ti.com/clocks
Interface	interface.ti.com
Logic	logic.ti.com
Power Mgmt	power.ti.com
Microcontrollers	microcontroller.ti.com
RFID	www.ti-rfid.com
OMAP Applications Processors	www.ti.com/omap
Wireless Connectivity	www.ti.com/wirelessconnectivity

Applications

Automotive and Transportation	www.ti.com/automotive
Communications and Telecom	www.ti.com/communications
Computers and Peripherals	www.ti.com/computers
Consumer Electronics	www.ti.com/consumer-apps
Energy and Lighting	www.ti.com/energy
Industrial	www.ti.com/industrial
Medical	www.ti.com/medical
Security	www.ti.com/security
Space, Avionics and Defense	www.ti.com/space-avionics-defense
Video and Imaging	www.ti.com/video

TI E2E Community

e2e.ti.com