

DRV10866 5-V, 3-Phase, Sensorless BLDC Motor Driver

1 Features

- Input Voltage Range: 1.65 V to 5.5 V
- Six Integrated MOSFETS With 680-mA Peak Output Current
- Ultralow Quiescent Current: 5 μ A (Typical) in Standby Mode
- Total Driver H+L $R_{DS(on)}$ 900 m Ω
- Sensorless Proprietary BMEF Control Scheme
- 150° Commutation
- Synchronous Rectification PWM Operation
- Selectable FG and 1/2 FG Open-Drain Output
- PWM_{IN} Input from 15 kHz to 50 kHz
- Lock Detection
- Voltage Surge Protection
- UVLO
- Thermal Shutdown

2 Applications

- Notebook CPU Fans
- Game Station CPU Fans
- ASIC Cooling Fans

3 Description

DRV10866 is a 3-phase, sensorless motor driver with integrated power MOSFETs with drive current capability up to 680-mA peak. DRV10866 is specifically designed for low noise and low external component count fan motor drive applications. DRV10866 has built-in overcurrent protection with no external current sense resistor needed. The synchronous rectification mode of operation achieves increased efficiency for motor driver applications. DRV10866 outputs either FG or 1/2 FG to indicate motor speed with open-drain output. A 150° sensorless BEMF control scheme is implemented for a 3-phase motor. DRV10866 is available in the thermally efficient 10-pin, 3-mm x 3-mm x 0.75-mm SON (DSC) package. The operating temperature is specified from -40°C to 125°C.

Device Information⁽¹⁾

PART NUMBER	PACKAGE	BODY SIZE (NOM)
DRV10866	WSON (10)	3.00 mm x 3.00 mm

(1) For all available packages, see the orderable addendum at the end of the data sheet.

DRV10866 Typical Application

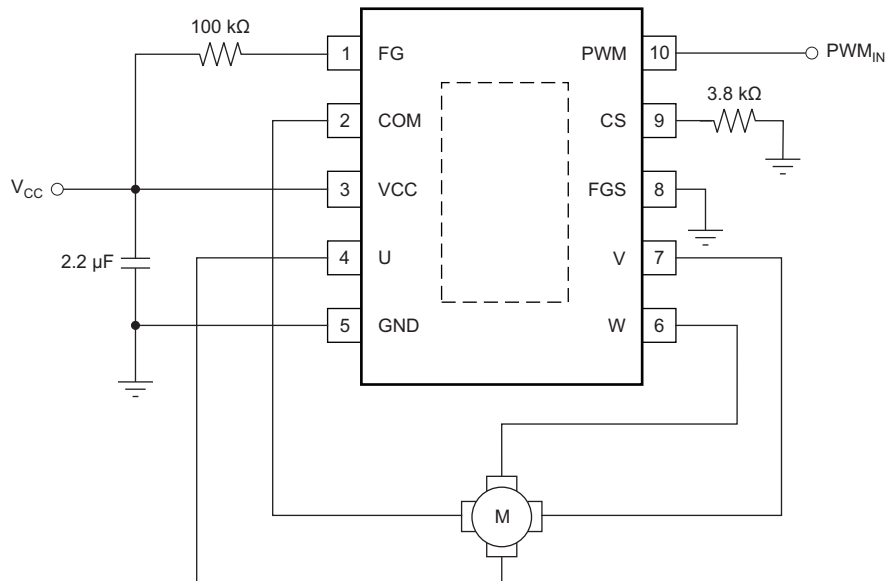

Table of Contents

1 Features	1	7.3 Feature Description.....	8
2 Applications	1	7.4 Device Functional Modes.....	9
3 Description	1	8 Application and Implementation	10
4 Revision History	2	8.1 Application Information.....	10
5 Pin Configuration and Functions	3	8.2 Typical Application	10
6 Specifications	4	9 Power Supply Recommendations	14
6.1 Absolute Maximum Ratings	4	10 Layout	14
6.2 ESD Ratings.....	4	10.1 Layout Guidelines	14
6.3 Recommended Operating Conditions.....	4	10.2 Layout Example	14
6.4 Thermal Information	4	11 Device and Documentation Support	15
6.5 Electrical Characteristics.....	5	11.1 Trademarks	15
6.6 Typical Characteristics.....	6	11.2 Electrostatic Discharge Caution.....	15
7 Detailed Description	7	11.3 Glossary	15
7.1 Overview	7	12 Mechanical, Packaging, and Orderable Information	15
7.2 Functional Block Diagram	7		

4 Revision History

Changes from Original (November 2012) to Revision A

Page

- Added *Pin Configuration and Functions* section, *ESD Ratings* table, *Feature Description* section, *Device Functional Modes*, *Application and Implementation* section, *Power Supply Recommendations* section, *Layout* section, *Device and Documentation Support* section, and *Mechanical, Packaging, and Orderable Information* section **1**

5 Pin Configuration and Functions

**10-Pins WSON with Thermal Pad
DSC Package
Top View**

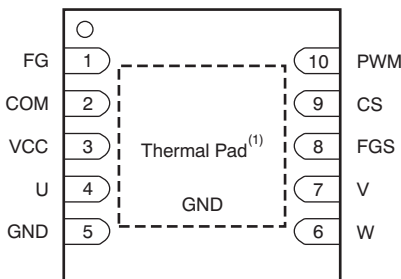

(1) Thermal pad connected to ground.

Pin Functions

PIN		I/O	DESCRIPTION
NAME	NO.		
COM	2	I	Motor common terminal input
CS	9	I	Overcurrent threshold setup pin. The constant current of the internal constant current source flows through the resistor connected to this pin. The other side of the resistor is connected to ground. The voltage across the resistor compares with the voltage converted from the bottom MOSFET current. If the MOSFET current is high, the part enters the overcurrent protection mode by turning off the top PWM MOSFET and holding the bottom MOSFET on. I (mA) = $3120/R_{CS}(k\Omega)$. Equation valid range: $300\text{ mA} < I_{LIMIT} < 850\text{ mA}$
FG	1	O	Frequency generator output. If the FGS pin is connected to ground, the output has a period equal to one electrical cycle (FG). If the FGS pin is connected to VCC, the output has a period equal to two electrical cycles (1/2FG).
FGS	8	I	FG and 1/2FG control pin. Latched upon wake-up signal from the PWM pin. For details, refer to Frequency Generator .
GND	5	—	Ground pin
PWM	10	I	PWM input pin. The PWM input signal is converted to a fixed 156-kHz switching frequency on the MOSFET driver. The PWM input signal resolution is less than 1%. This pin can also control the device and put it in or out of standby mode. After the signal at the PWM stays low (up to 500 μ s), the device goes into low-power standby mode. Standby current is approximately 5 μ A. The rising edge of the PWM signal wakes up the device and puts it into active mode, where it is ready to start to turn the motor.
U	4	O	Phase U output
V	7	O	Phase V output
VCC	3	I	Input voltage for motor and chip-supply voltage; the internal clamping circuit clamps the V _{CC} voltage.
W	6	O	Phase W output

6 Specifications

6.1 Absolute Maximum Ratings

Over operating free-air temperature range (unless otherwise noted).⁽¹⁾

		MIN	MAX	UNIT
Input voltage ⁽²⁾	VCC	-0.3	6.0	V
	CS, FGS, PWM	-0.3	6.0	V
	GND	-0.3	0.3	V
	COM	-1.0	6.0	V
Output voltage ⁽²⁾	U, V, W	-1.0	7.0	V
	FG	-0.3	6.0	V
Temperature	Operating junction temperature, T _J	-40	125	°C
	Storage temperature, T _{stg}	-55	150	°C

(1) Stresses beyond those listed under *Absolute Maximum Ratings* may cause permanent damage to the device. These are stress ratings only, which do not imply functional operation of the device at these or any other conditions beyond those indicated under *Recommended Operating Conditions*. Exposure to absolute-maximum-rated conditions for extended periods may affect device reliability.

(2) All voltage values are with respect to network ground terminal unless otherwise noted.

6.2 ESD Ratings

		VALUE	UNIT
V _(ESD) Electrostatic discharge	Human body model (HBM), per ANSI/ESDA/JEDEC JS-001 ⁽¹⁾	±4000	V
	Charged-device model (CDM), per JEDEC specification JESD22-C101 ⁽²⁾	±500	

(1) JEDEC document JEP155 states that 500-V HBM allows safe manufacturing with a standard ESD control process.

(2) JEDEC document JEP157 states that 250-V CDM allows safe manufacturing with a standard ESD control process.

6.3 Recommended Operating Conditions

Over operating free-air temperature range (unless otherwise noted).

		MIN	MAX	UNIT
Supply voltage	VCC	1.65	5.5	V
Voltage range	U, V, W	-0.7	6.5	V
	FG, CS, FGS, COM	-0.1	5.5	V
	GND	-0.1	0.1	V
	PWM	-0.1	5.5	V
Operating junction temperature, T _J		-40	125	°C

6.4 Thermal Information

THERMAL METRIC ⁽¹⁾		DRV10866	UNIT
		DSC (WSON)	
		10 PINS	
R _{θJA}	Junction-to-ambient thermal resistance	42.3	°C/W
R _{θJC(top)}	Junction-to-case (top) thermal resistance	44.5	
R _{θJB}	Junction-to-board thermal resistance	17.1	
Ψ _{JT}	Junction-to-top characterization parameter	0.3	
Ψ _{JB}	Junction-to-board characterization parameter	17.3	
R _{θJC(bot)}	Junction-to-case (bottom) thermal resistance	4.3	

(1) For more information about traditional and new thermal metrics, see the *IC Package Thermal Metrics* application report, [SPRA953](http://www.ti.com/lit/zip/Spra953).

6.5 Electrical Characteristics

Over operating free-air temperature range (unless otherwise noted).

PARAMETER		TEST CONDITIONS	MIN	TYP	MAX	UNIT
SUPPLY CURRENT						
I_{VCC}	Supply current	$T_A = +25^\circ\text{C}$; PWM = V_{CC} ; $V_{CC} = 5\text{ V}$		2.5	3.5	mA
$I_{VCC\text{-Standby}}$	Standby current	$T_A = +25^\circ\text{C}$; PWM = 0 V; $V_{CC} = 5\text{ V}$		5	10	μA
UVLO						
$V_{UVLO\text{-Th}_r}$	UVLO threshold voltage, rising	Rise threshold, $T_A = +25^\circ\text{C}$		1.80	1.9	V
$V_{UVLO\text{-Th}_f}$	UVLO threshold voltage, falling	Fall threshold, $T_A = +25^\circ\text{C}$	1.6	1.65		V
$V_{UVLO\text{-Th}_{hys}}$	UVLO threshold voltage, hysteresis	$T_A = +25^\circ\text{C}$	75	150	225	mV
INTEGRATED MOSFET						
R_{DSON}	Series resistance (H+L)	$T_A = +25^\circ\text{C}$; $V_{CC} = 5\text{ V}$; $I_O = 0.5\text{ A}$		0.8	1.2	Ω
		$T_A = +25^\circ\text{C}$; $V_{CC} = 4\text{ V}$; $I_O = 0.5\text{ A}$		0.9	1.4	
		$T_A = +25^\circ\text{C}$; $V_{CC} = 3\text{ V}$; $I_O = 0.5\text{ A}$		1.1	1.7	
PWM						
$V_{PWM\text{-IH}}$	High-level input voltage	$V_{CC} \geq 4.5\text{ V}$	2.3			V
$V_{PWM\text{-IL}}$	Low-level input voltage	$V_{CC} \geq 4.5\text{ V}$			0.8	V
F_{PWM}	PWM input frequency		15		50	kHz
$I_{PWM\text{-Source}}$		Standby mode, $V_{CC} = 5\text{ V}$		5		μA
		Active mode, $V_{CC} = 5\text{ V}$		100		
T_{STBY}		PWM = 0		500		μs
FG AND FGS						
$I_{FG\text{-Sink}}$	FG pin sink current	$V_{FG} = 0.3\text{ V}$	5			mA
$V_{FGS\text{-Th}}$	FG set threshold voltage	FG pin output, full FG signal, $V_{CC} \geq 4.5\text{ V}$			0.8	V
		FG pin output, one-half FG signal, $V_{CC} \geq 4.5\text{ V}$	2.3			
LOCK PROTECTION						
$T_{LOCK\text{-On}}$	Lock detect time	FG = 0	2	3	4	s
$T_{LOCK\text{-Off}}$	Lock release time		2.5	5	7.5	s
CURRENT LIMIT						
	Current limit	CS pin to GND resistor = 3.9 k Ω	680	800	920	mA
THERMAL SHUTDOWN						
T_{SHDN}	Shutdown temperature threshold			160		$^\circ\text{C}$
		Hysteresis		10		

6.6 Typical Characteristics

At $T_A = +25^\circ\text{C}$, with standard cooling fan, unless otherwise noted.

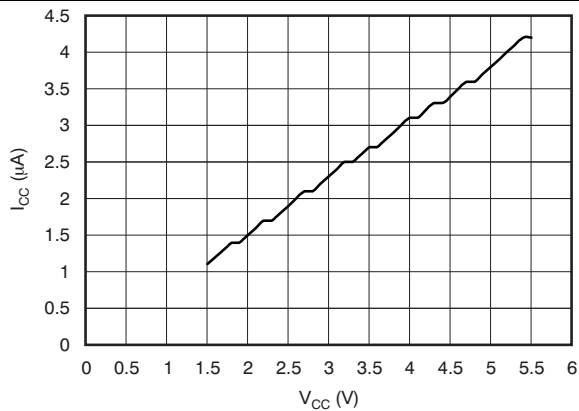

Figure 1. Standby Current vs Input Voltage

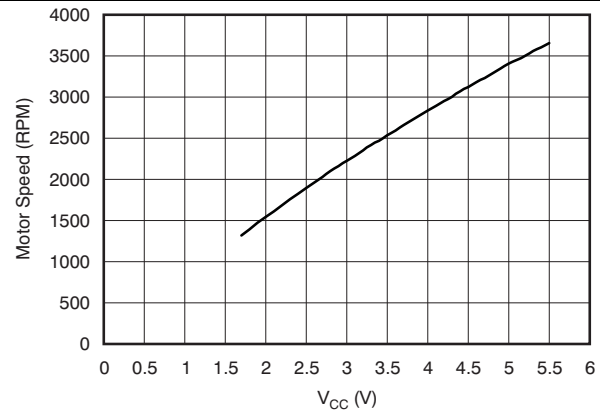

Figure 2. RPM vs Input Voltage

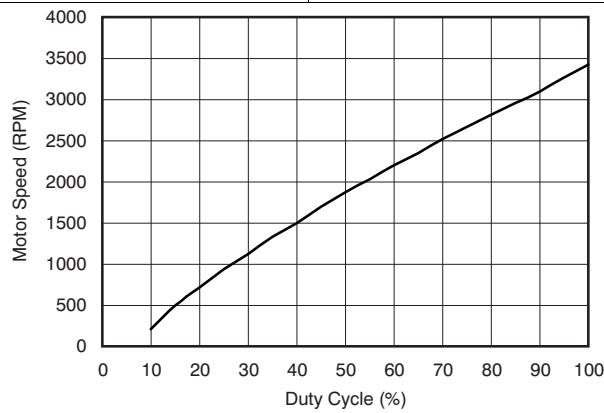

Figure 3. RPM vs Duty Cycle

7 Detailed Description

7.1 Overview

DRV10866 is a 3-phase, sensorless motor driver with integrated power MOSFETs with drive current capability up to 680-mA peak. DRV10866 is specifically designed for low noise, low external component count fan motor drive applications. DRV10866 has built-in overcurrent protection with no external current sense resistor needed. The synchronous rectification mode of operation achieves increased efficiency for motor driver applications. DRV10866 can output either FG or 1/2 FG to indicate motor speed with open-drain output through FGS pin selection. A 150° sensorless BEMF control scheme is implemented for a 3-phase motor. Voltage surge protection scheme prevents input V_{CC} capacitor from over charge during motor acceleration and deceleration modes. DRV10866 has multiple built-in protection blocks including UVLO, overcurrent protection, lock protection and thermal shutdown protection.

7.2 Functional Block Diagram

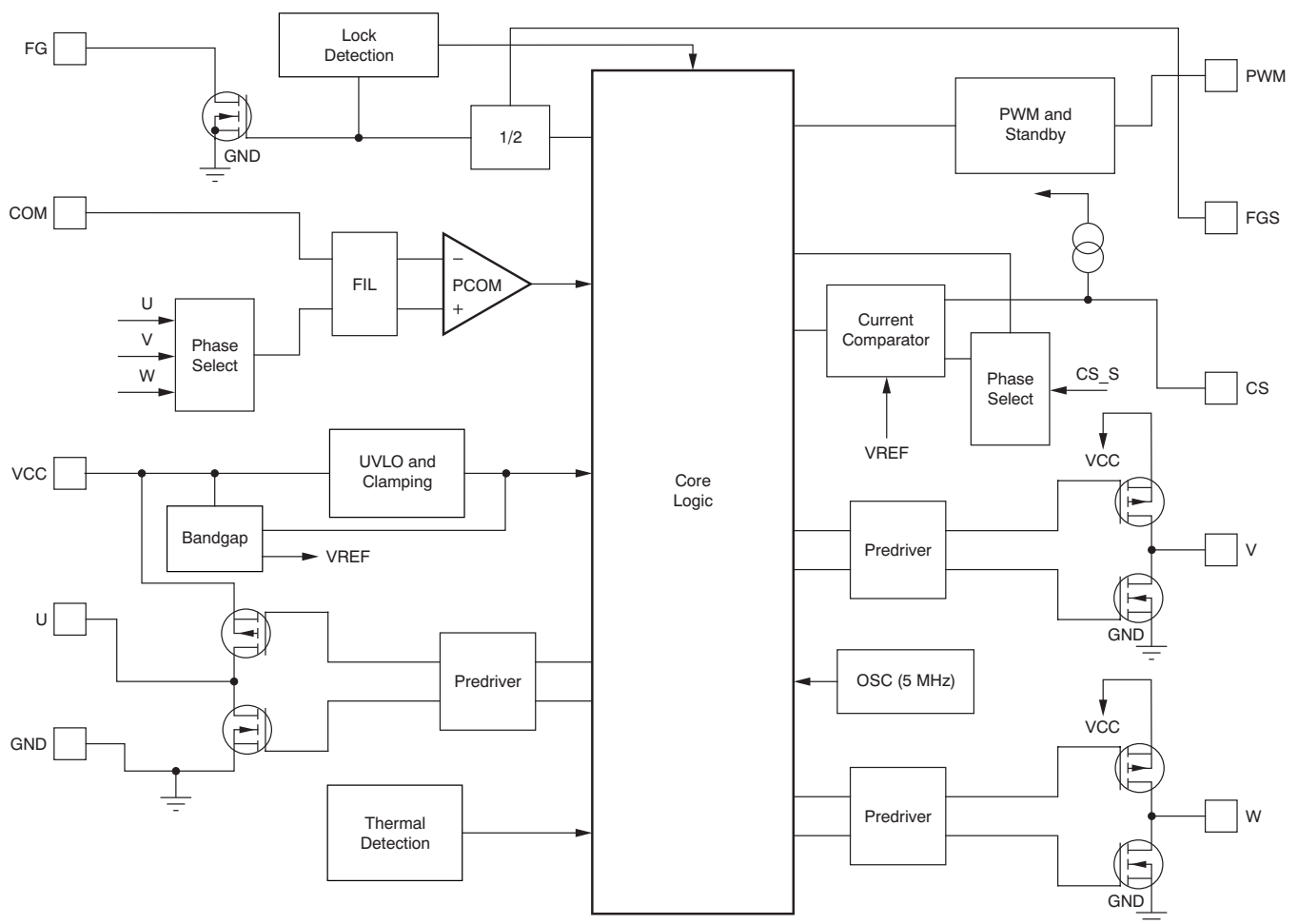

7.3 Feature Description

7.3.1 Speed Control

DRV10866 can control motor speed through either the PWM_{IN} or V_{CC} pin. Motor speed will increase with higher PWM_{IN} duty cycle or V_{CC} input voltage. The curve of motor speed (RPM) vs PWM_{IN} duty cycle or V_{CC} input voltage is close to linear in most cases. However, motor characteristics will affect the linearity of this speed curve. DRV10866 can operate at very low V_{CC} input voltage down to 1.65 V. The PWM_{IN} pin is pulled up to V_{CC} internally and frequency range can vary from 15 kHz to 50 kHz. The motor driver MOSFETs will operate at constant switching frequency 156 kHz. With this high switching frequency, DRV10866 can eliminate audible noise and reduce the ripple of V_{CC} input voltage and current, and thus minimize EMI noise.

7.3.2 Frequency Generator

The FG pin outputs a 50% duty cycle of PWM waveform in the normal operation condition. The frequency of the FG signal represents the motor speed and phase information. The FG pin is an open-drain output, so an external pullup resistor is needed when connected to an external system. During the start-up, FG output will stay at high impedance until the motor speed reaches a certain level and BEMF is detected. During lock protection condition, FG output will remain high until the motor restarts and start-up process is completed. DRV10866 can output either FG or ½ FG to indicate motor status with open-drain output through FGS pin selection. When FGS is pulled to V_{CC}, the frequency of FG output is half of that when FGS is pulled to GND. Motor speed can be calculated based on the FG frequency when FGS is pulled to GND, which equals to:

$$\text{RPM} = \frac{(\text{FG} \times 60)}{\text{pole pairs}}$$

where

- FG is in hertz (Hz). (1)

7.3.3 Lock Protection

If the motor is blocked or stopped by an external force, the lock protection is triggered after lock detection time. During lock detection time, the circuit monitors the PWM and FG signals. If PWM has an input signal while the FG output is in high impedance during this period, the lock protection will be enabled and DRV10866 will stop driving the motor. After lock release time, DRV10866 will resume driving the motor again. If the lock condition still exists, DRV10866 will proceed with the next lock protection cycle until the lock condition is removed. With this lock protection, the motor and device will not get over heated or be damaged.

7.3.4 Voltage Surge Protection

The DRV10866 has a unique feature to clamp the V_{CC} voltage during lock protection and standby mode. If the lock mode condition is caused by an external force that suddenly stops the motor at a high speed, or the device goes into standby mode from a high duty cycle, either situation releases the energy in the motor winding into the input capacitor. When a small input capacitor and anti-reverse diode are used in the system design, the input voltage of the IC could rise above the absolute voltage rate of the chip. This condition either destroys the device or reduces the reliability of the device. For this reason, the DRV10866 has a voltage clamp circuit that clamps the input voltage at 5.95 V, and has a hysteresis of 150 mV. This clamp circuit is only active during the lock protection cycle or when the device enters standby mode. It is disabled during normal operation.

7.3.5 Overcurrent Protection

The DRV10866 can adjust the overcurrent point through an external resistor connected to the CS pin (pin 9) and ground. Without this external current sense resistor, the DRV10866 senses the current through the power MOSFET. Therefore, there is no power loss during the current sensing. The current sense architecture improves the overall system efficiency. Shorting the CS pin to ground disables the overcurrent protection feature. During overcurrent protection, the DRV10866 only limits the current to the motor; it does not shut down the device. The overcurrent limit can be set by the value of current sensing resistor through [Equation 2](#).

$$I \text{ (A)} = \frac{3120}{R_{CS} \text{ (}\Omega\text{)}} \quad (2)$$

Feature Description (continued)

7.3.6 Undervoltage Lockout (UVLO)

The DRV10866 has a built-in UVLO function block. The hysteresis of UVLO threshold is 150 mV. The device will be locked out when V_{CC} reaches 1.65 V and woke up at 1.8 V.

7.3.7 Thermal Shutdown

The DRV10866 has a built-in thermal shunt down function, which will shut down the device when the junction temperature is over 160°C and will resume operating when the junction temperature drops back to 150°C.

7.4 Device Functional Modes

7.4.1 Start-up

At start-up with motor at standstill, commutation logic starts to drive the motor in open-loop with U-phase high, V-phase low, and the W-phase shut off. During open-loop start-up phase, commutation logic advance to next state automatically as per [Table 1](#) with duty cycle of 100% regardless of PWM input. At each state, commutation logic detects zero-crossing of back-emf at shut-off phase. Once motor reaches to sufficient speed to allow four consecutive successful back-emf zero-crossing, commutation logic switches to closed-loop operation mode as explained in next section.

In certain cases, the motor may have initial speed in forward direction when the device attempts to start-up the motor again. When this occurs, device commutation logic jumps over the open-loop start-up process and goes to closed loop directly. By re-synchronizing to the spinning motor, the user achieves the fastest possible start-up time for this initial condition.

7.4.2 Motor Running at Steady-State Speed

Once open-loop acceleration phase is over, motor steady state speed is determined by applied duty-cycle at PWM input. In this mode, communication logic steps through the six states mentioned in [Table 1](#) and next commutation state is determined by actual back-emf zero-crossing event at shut-off phase. Each state remains for 150°. This is an advanced trapezoidal method that allows the device to drive the phases gradually to the maximum current and gradually to 0. Commutation logic also provides the required 15° angle-advance from zero-crossing events to efficiently commutate the motor.

For a given duty-cycle input, motor speed can be different depending upon the motor loading conditions. Device provides motor speed information at FG pin which can be used to achieve closed-loop speed control to get constant speed at varying load condition.

7.4.3 Motor Stopping

Motor can be decelerated gradually by slowly reducing the PWM duty command to avoid overvoltage at DC input. When the device is commanded to decelerate very fast or stop the motor suddenly from high speed, in order to protect the IC and the system, the DRV10866 goes into AVS protection, as explained in [Voltage Surge Protection](#).

Table 1. Commutation Table

COMMUTATION STATE	PHASE_U	PHASE_V	PHASE_W
State 1	High	Low	Off
State 2	High	Off	Low
State 3	Off	High	Low
State 4	Low	High	Off
State 5	Low	Off	High
State 6	Off	Low	High

8 Application and Implementation

NOTE

Information in the following applications sections is not part of the TI component specification, and TI does not warrant its accuracy or completeness. TI's customers are responsible for determining suitability of components for their purposes. Customers should validate and test their design implementation to confirm system functionality.

8.1 Application Information

DRV10866 only requires three external components. The device needs a 2.2- μ F or higher ceramic capacitor connected to VCC and ground for decoupling. During layout, the strategy of ground copper pour is very important to enhance the thermal performance. For two or more layers, use eight thermal vias. Refer to Layout Example for an example of the PCB layout. If there is no COM pin on the motor, one can be simulated. Use three resistors connected in a wye formation, one connected to U, one to V, and one to W. Connect the resistor ends opposite of the phases together. This center point is COM. To find the proper resistor value, start with a value of 10 k Ω and continue to decrease by 1 k Ω until the motor runs properly.

8.2 Typical Application

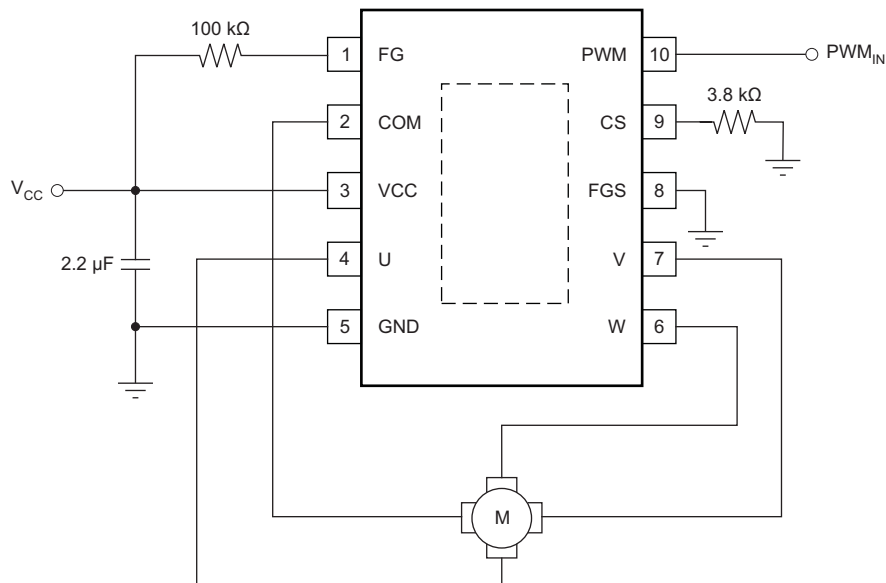

Figure 4. Typical Application Schematic

8.2.1 Design Requirements

For this design example, use the parameters listed in [Table 2](#) as the input parameters.

Table 2. Recommended Application Range

		MIN	TYP	MAX	UNIT
Motor voltage		1.6		5.5	V
VCC capacitor	Place as close to the pin as possible		2.2		μ F
Operating current		Running with normal load at rated speed		500	mA
Absolute max current		During start-up and locked motor condition		650	mA

8.2.2 Detailed Design Procedure

- Refer to the [Design Requirements](#) and ensure the system meets the recommended application range.
 - Ensure the VCC level is in between 1.6 and 5.5 V
 - Verify the motor needs no more than 500 mA during runtime.
- Follow the application and [Power Supply Recommendations](#) when constructing the schematic.
 - Make sure there is adequate capacitance on VCC.
 - Size the resistor on CS according to the details given in [Feature Description](#).
 - Use a pullup on FG.
 - If the motor doesn't have a common pin, create one using the method listed in [Application Information](#).
- Build the hardware according to the [Layout Guidelines](#).
- Test the system with the application's motor to verify proper operation.

8.2.3 Application Curves

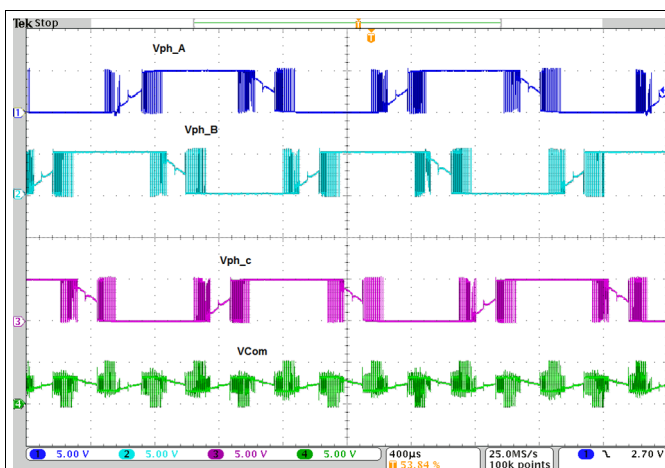

Figure 5. Normal Operation With Vcom at 5 V

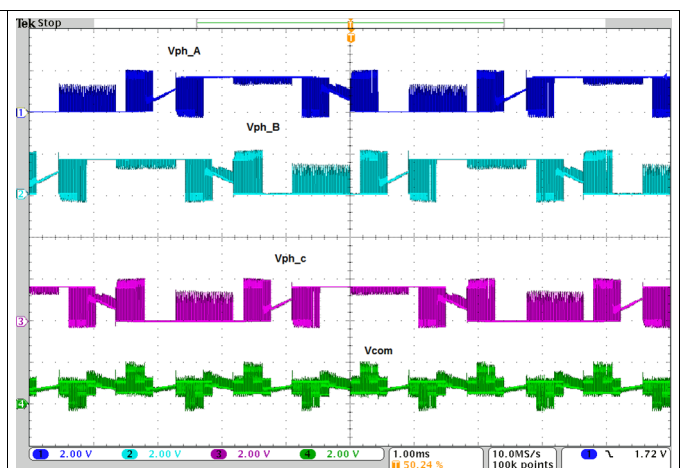

Figure 6. Normal Operation With Vcom at 1.65 V

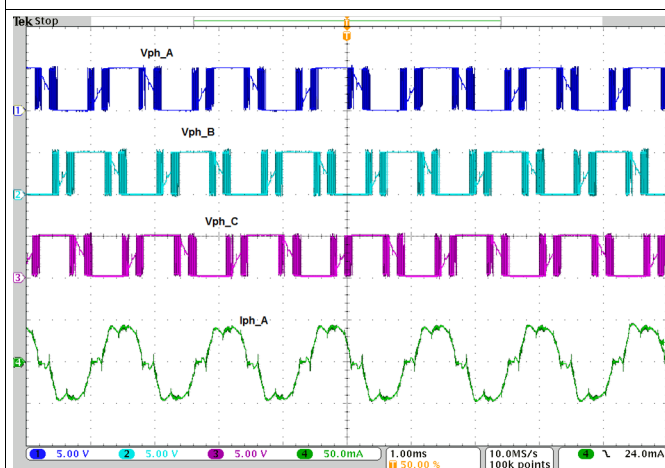

Figure 7. Normal Operation With 3-Phase Voltage and ph-A Current at 5 V

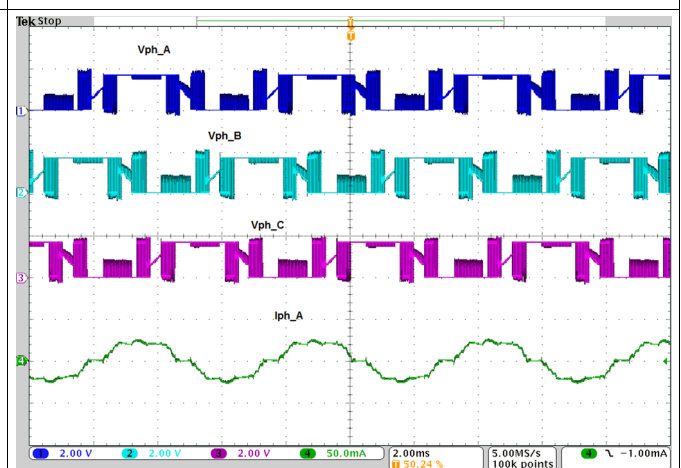

Figure 8. Normal Operation With 3-Phase Voltage and ph-A Current at 1.65 V

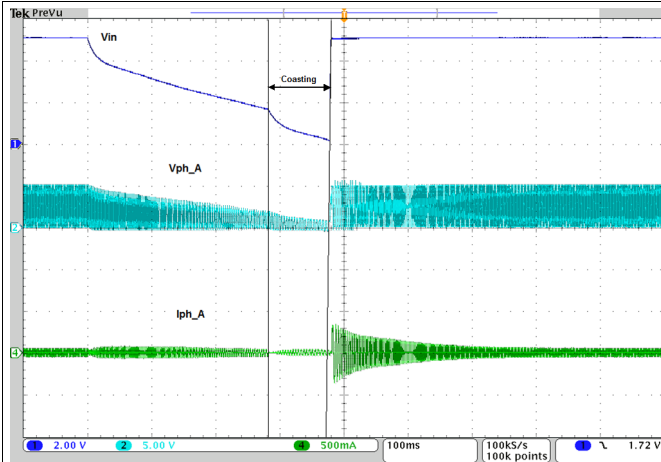

Figure 9. Re-Synchronizing to Spinning Motor During Power On-Off Cycle at 5 V

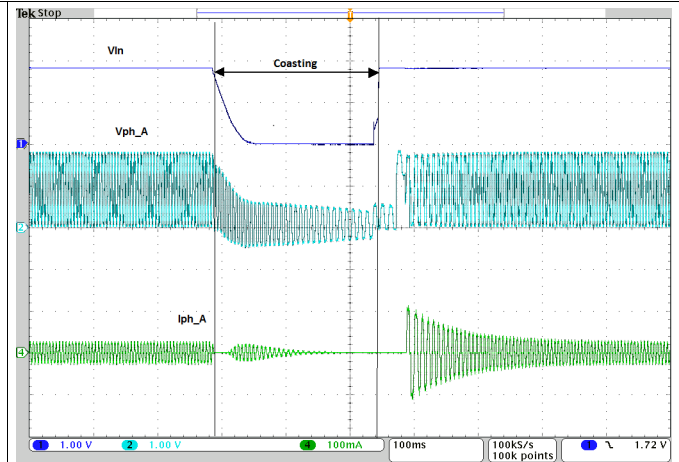

Figure 10. Re-Synchronizing to Spinning Motor During Power On-Off Cycle at 1.8 V

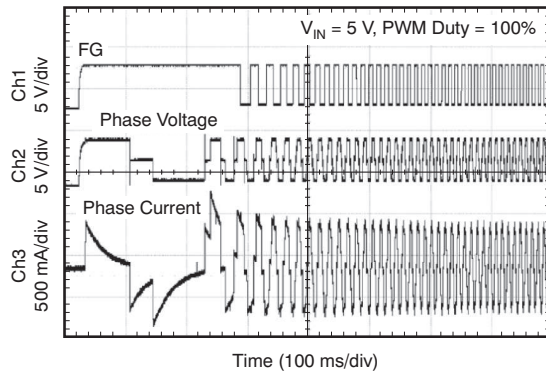

Figure 11. Start-Up at 100% Duty Cycle

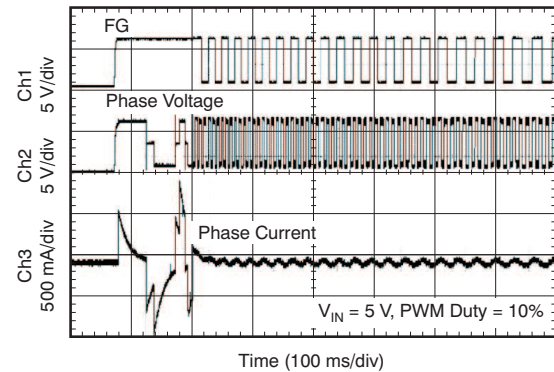

Figure 12. Start-Up at 10% Duty Cycle

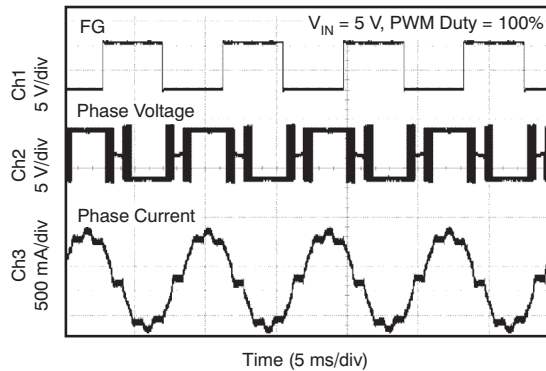

Figure 13. Normal Operation at 100% Duty Cycle

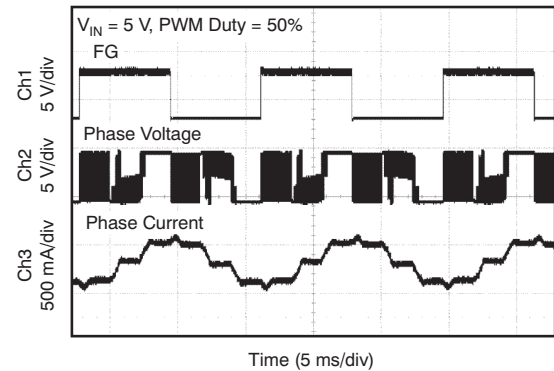

Figure 14. Normal Operation at 50% Duty Cycle

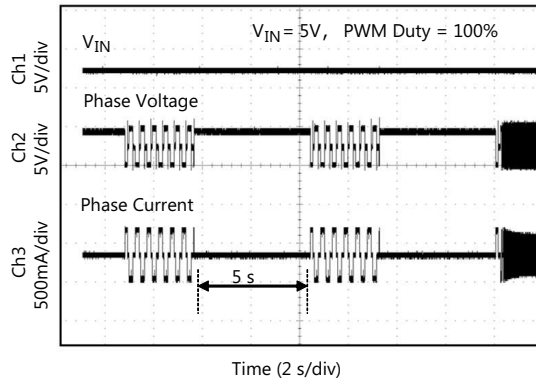

Figure 15. Lock Protection

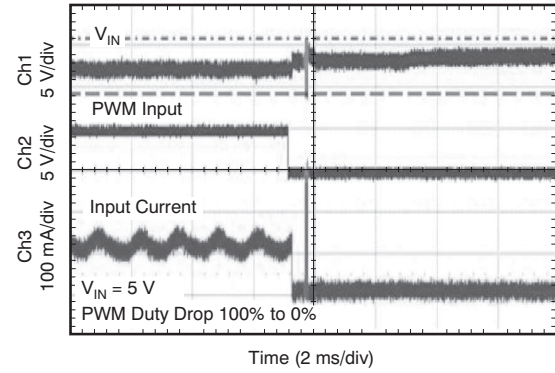

Figure 16. Clamp Voltage at Standby Mode

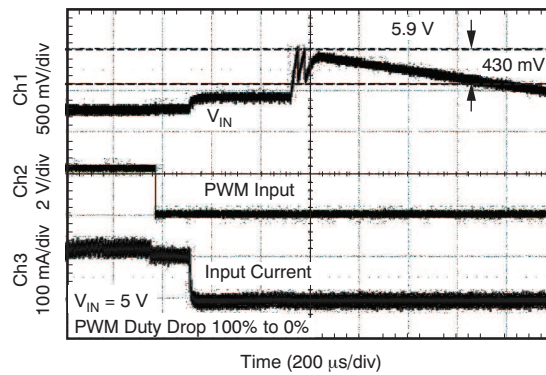

Figure 17. Clamp Voltage at Standby Mode Enlarged View

9 Power Supply Recommendations

The DRV10866 is designed to operate from an input voltage supply, VCC, range from 1.65 V to 5.5 V. The user must place a 2.2- μ F ceramic capacitor rated for VCC as close as possible to the VCC and GND pin. If the power supply ripple is more than 100 mV, in addition to the local decoupling capacitors, a bulk capacitance is required and must be sized according to the application requirements. If the bulk capacitance is implemented in the application, the user can reduce the value of the local ceramic capacitor to 220 nF.

10 Layout

10.1 Layout Guidelines

The DRV10866 is simple to design with a single-layer or two layer printed-circuit-board (PCB) layout. During layout, the strategy of ground copper pour is very important to enhance the thermal performance. Use vias on the thermal pad to dissipate heat away from the IC. Refer to [Figure 18](#) for an example of PCB layout.

- Place VCC, GND, U, V, and W pins with thick traces because high current passes through these traces.
- Place the 2.2- μ F capacitor between VCC and GND, and as close to the VCC and GND pins as possible.
- Connect the GND under the thermal pad.
- Keep the thermal pad connection as large as possible, both on the bottom side and top side. It should be one piece of copper without any gaps.

10.2 Layout Example

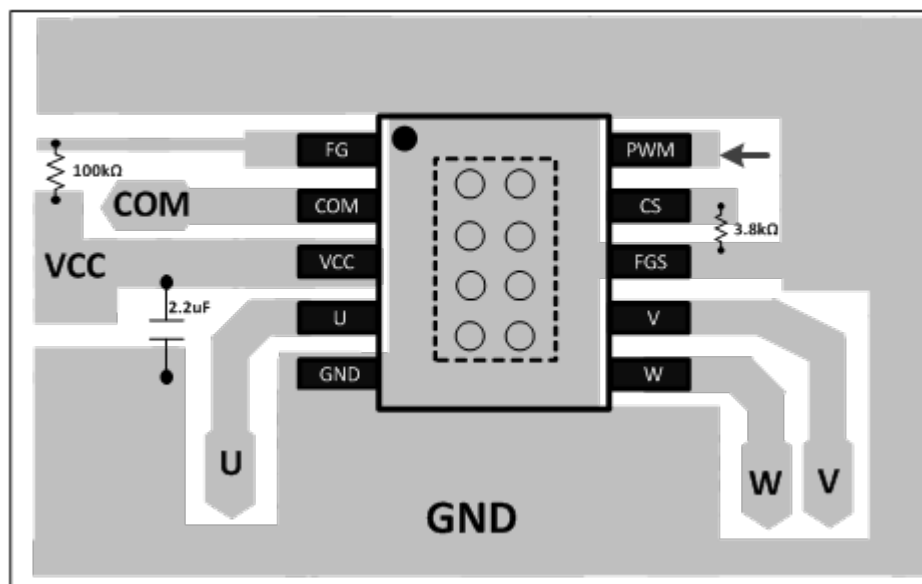

Figure 18. PCB Layout Example

11 Device and Documentation Support

11.1 Trademarks

All trademarks are the property of their respective owners.

11.2 Electrostatic Discharge Caution



These devices have limited built-in ESD protection. The leads should be shorted together or the device placed in conductive foam during storage or handling to prevent electrostatic damage to the MOS gates.

11.3 Glossary

[SLYZ022](#) — *TI Glossary*.

This glossary lists and explains terms, acronyms, and definitions.

12 Mechanical, Packaging, and Orderable Information

The following pages include mechanical, packaging, and orderable information. This information is the most current data available for the designated devices. This data is subject to change without notice and revision of this document. For browser-based versions of this data sheet, refer to the left-hand navigation.

PACKAGING INFORMATION

Orderable Device	Status (1)	Package Type	Package Drawing	Pins	Package Qty	Eco Plan (2)	Lead/Ball Finish (6)	MSL Peak Temp (3)	Op Temp (°C)	Device Marking (4/5)	Samples
DRV10866DSCR	ACTIVE	WSON	DSC	10	3000	Green (RoHS & no Sb/Br)	CU NIPDAU	Level-2-260C-1 YEAR	-40 to 85	10866	Samples

(1) The marketing status values are defined as follows:

ACTIVE: Product device recommended for new designs.

LIFEBUY: TI has announced that the device will be discontinued, and a lifetime-buy period is in effect.

NRND: Not recommended for new designs. Device is in production to support existing customers, but TI does not recommend using this part in a new design.

PREVIEW: Device has been announced but is not in production. Samples may or may not be available.

OBSOLETE: TI has discontinued the production of the device.

(2) Eco Plan - The planned eco-friendly classification: Pb-Free (RoHS), Pb-Free (RoHS Exempt), or Green (RoHS & no Sb/Br) - please check <http://www.ti.com/productcontent> for the latest availability information and additional product content details.

TBD: The Pb-Free/Green conversion plan has not been defined.

Pb-Free (RoHS): TI's terms "Lead-Free" or "Pb-Free" mean semiconductor products that are compatible with the current RoHS requirements for all 6 substances, including the requirement that lead not exceed 0.1% by weight in homogeneous materials. Where designed to be soldered at high temperatures, TI Pb-Free products are suitable for use in specified lead-free processes.

Pb-Free (RoHS Exempt): This component has a RoHS exemption for either 1) lead-based flip-chip solder bumps used between the die and package, or 2) lead-based die adhesive used between the die and leadframe. The component is otherwise considered Pb-Free (RoHS compatible) as defined above.

Green (RoHS & no Sb/Br): TI defines "Green" to mean Pb-Free (RoHS compatible), and free of Bromine (Br) and Antimony (Sb) based flame retardants (Br or Sb do not exceed 0.1% by weight in homogeneous material)

(3) MSL, Peak Temp. - The Moisture Sensitivity Level rating according to the JEDEC industry standard classifications, and peak solder temperature.

(4) There may be additional marking, which relates to the logo, the lot trace code information, or the environmental category on the device.

(5) Multiple Device Markings will be inside parentheses. Only one Device Marking contained in parentheses and separated by a "~" will appear on a device. If a line is indented then it is a continuation of the previous line and the two combined represent the entire Device Marking for that device.

(6) Lead/Ball Finish - Orderable Devices may have multiple material finish options. Finish options are separated by a vertical ruled line. Lead/Ball Finish values may wrap to two lines if the finish value exceeds the maximum column width.

Important Information and Disclaimer: The information provided on this page represents TI's knowledge and belief as of the date that it is provided. TI bases its knowledge and belief on information provided by third parties, and makes no representation or warranty as to the accuracy of such information. Efforts are underway to better integrate information from third parties. TI has taken and continues to take reasonable steps to provide representative and accurate information but may not have conducted destructive testing or chemical analysis on incoming materials and chemicals. TI and TI suppliers consider certain information to be proprietary, and thus CAS numbers and other limited information may not be available for release.

In no event shall TI's liability arising out of such information exceed the total purchase price of the TI part(s) at issue in this document sold by TI to Customer on an annual basis.

TAPE AND REEL INFORMATION



QUADRANT ASSIGNMENTS FOR PIN 1 ORIENTATION IN TAPE



*All dimensions are nominal

Device	Package Type	Package Drawing	Pins	SPQ	Reel Diameter (mm)	Reel Width W1 (mm)	A0 (mm)	B0 (mm)	K0 (mm)	P1 (mm)	W (mm)	Pin1 Quadrant
DRV10866DSCR	WSON	DSC	10	3000	330.0	12.4	3.3	3.3	1.1	8.0	12.0	Q2

TAPE AND REEL BOX DIMENSIONS



*All dimensions are nominal

Device	Package Type	Package Drawing	Pins	SPQ	Length (mm)	Width (mm)	Height (mm)
DRV10866DSCR	WSON	DSC	10	3000	367.0	367.0	35.0

DSC (S-PWSON-N10)

PLASTIC SMALL OUTLINE NO-LEAD

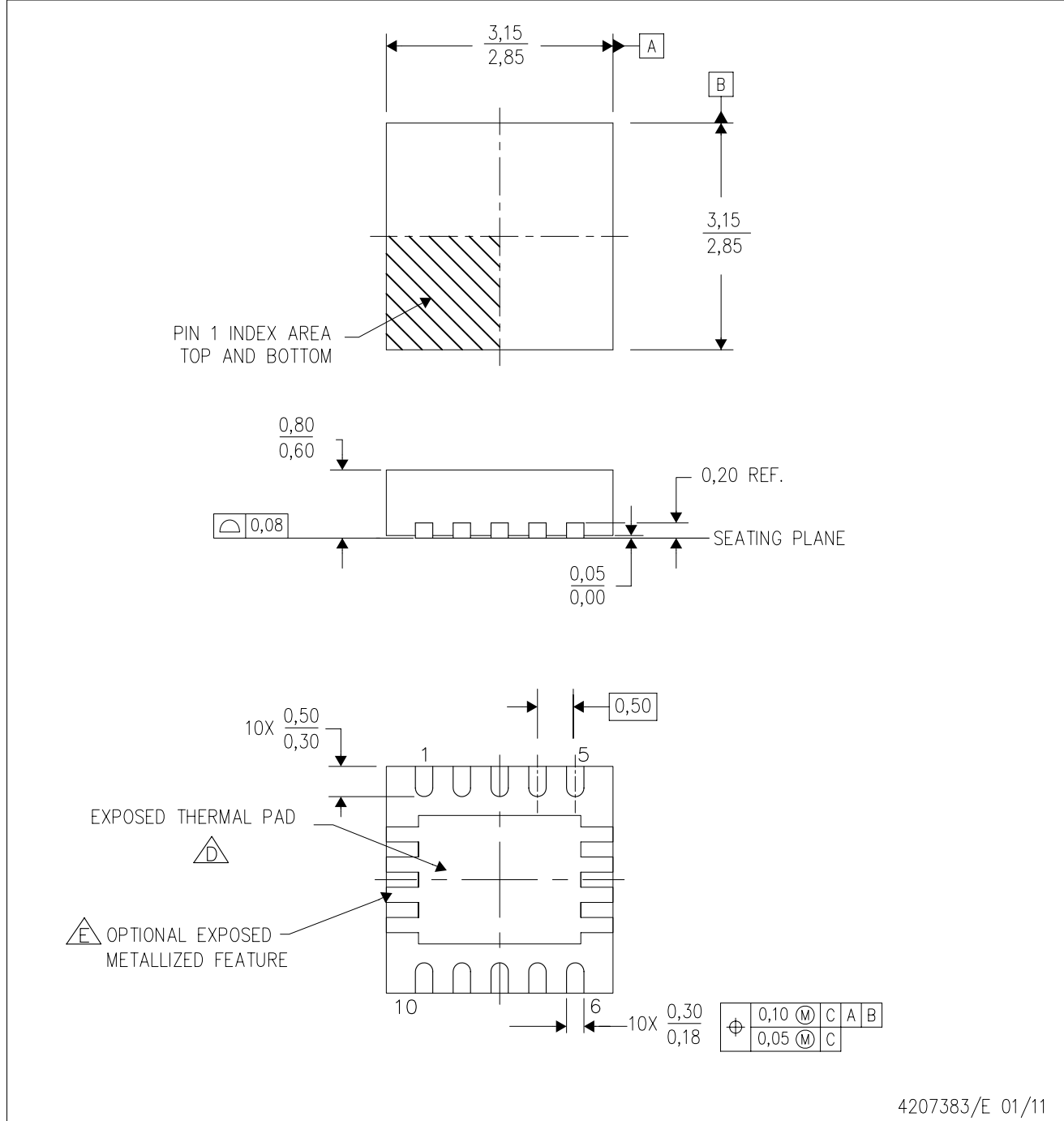

- NOTES: A. All linear dimensions are in millimeters. Dimensioning and tolerancing per ASME Y14.5M-1994.
 B. This drawing is subject to change without notice.
 C. Small Outline No-Lead (SON) package configuration.
 D. The package thermal pad must be soldered to the board for thermal and mechanical performance.
 E. See the Product Data Sheet for details regarding the exposed thermal pad features and dimensions.

THERMAL PAD MECHANICAL DATA

DSC (S-PWSON-N10)

PLASTIC SMALL OUTLINE NO-LEAD

THERMAL INFORMATION

This package incorporates an exposed thermal pad that is designed to be attached directly to an external heatsink. The thermal pad must be soldered directly to the printed circuit board (PCB). After soldering, the PCB can be used as a heatsink. In addition, through the use of thermal vias, the thermal pad can be attached directly to the appropriate copper plane shown in the electrical schematic for the device, or alternatively, can be attached to a special heatsink structure designed into the PCB. This design optimizes the heat transfer from the integrated circuit (IC).

For information on the Quad Flatpack No-Lead (QFN) package and its advantages, refer to Application Report, QFN/SON PCB Attachment, Texas Instruments Literature No. SLUA271. This document is available at www.ti.com.

The exposed thermal pad dimensions for this package are shown in the following illustration.

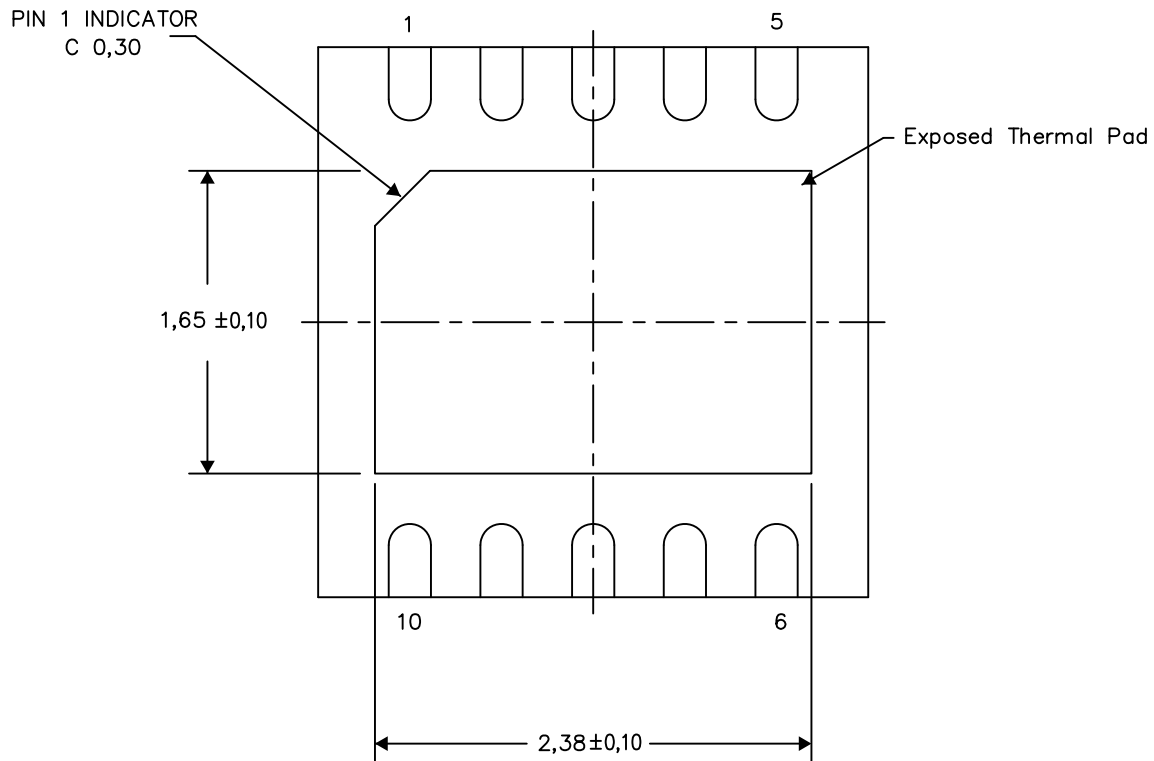

Bottom View

Exposed Thermal Pad Dimensions

4210391-6/N 01/14

NOTE: A. All linear dimensions are in millimeters

IMPORTANT NOTICE

Texas Instruments Incorporated and its subsidiaries (TI) reserve the right to make corrections, enhancements, improvements and other changes to its semiconductor products and services per JESD46, latest issue, and to discontinue any product or service per JESD48, latest issue. Buyers should obtain the latest relevant information before placing orders and should verify that such information is current and complete. All semiconductor products (also referred to herein as "components") are sold subject to TI's terms and conditions of sale supplied at the time of order acknowledgment.

TI warrants performance of its components to the specifications applicable at the time of sale, in accordance with the warranty in TI's terms and conditions of sale of semiconductor products. Testing and other quality control techniques are used to the extent TI deems necessary to support this warranty. Except where mandated by applicable law, testing of all parameters of each component is not necessarily performed.

TI assumes no liability for applications assistance or the design of Buyers' products. Buyers are responsible for their products and applications using TI components. To minimize the risks associated with Buyers' products and applications, Buyers should provide adequate design and operating safeguards.

TI does not warrant or represent that any license, either express or implied, is granted under any patent right, copyright, mask work right, or other intellectual property right relating to any combination, machine, or process in which TI components or services are used. Information published by TI regarding third-party products or services does not constitute a license to use such products or services or a warranty or endorsement thereof. Use of such information may require a license from a third party under the patents or other intellectual property of the third party, or a license from TI under the patents or other intellectual property of TI.

Reproduction of significant portions of TI information in TI data books or data sheets is permissible only if reproduction is without alteration and is accompanied by all associated warranties, conditions, limitations, and notices. TI is not responsible or liable for such altered documentation. Information of third parties may be subject to additional restrictions.

Resale of TI components or services with statements different from or beyond the parameters stated by TI for that component or service voids all express and any implied warranties for the associated TI component or service and is an unfair and deceptive business practice. TI is not responsible or liable for any such statements.

Buyer acknowledges and agrees that it is solely responsible for compliance with all legal, regulatory and safety-related requirements concerning its products, and any use of TI components in its applications, notwithstanding any applications-related information or support that may be provided by TI. Buyer represents and agrees that it has all the necessary expertise to create and implement safeguards which anticipate dangerous consequences of failures, monitor failures and their consequences, lessen the likelihood of failures that might cause harm and take appropriate remedial actions. Buyer will fully indemnify TI and its representatives against any damages arising out of the use of any TI components in safety-critical applications.

In some cases, TI components may be promoted specifically to facilitate safety-related applications. With such components, TI's goal is to help enable customers to design and create their own end-product solutions that meet applicable functional safety standards and requirements. Nonetheless, such components are subject to these terms.

No TI components are authorized for use in FDA Class III (or similar life-critical medical equipment) unless authorized officers of the parties have executed a special agreement specifically governing such use.

Only those TI components which TI has specifically designated as military grade or "enhanced plastic" are designed and intended for use in military/aerospace applications or environments. Buyer acknowledges and agrees that any military or aerospace use of TI components which have **not** been so designated is solely at the Buyer's risk, and that Buyer is solely responsible for compliance with all legal and regulatory requirements in connection with such use.

TI has specifically designated certain components as meeting ISO/TS16949 requirements, mainly for automotive use. In any case of use of non-designated products, TI will not be responsible for any failure to meet ISO/TS16949.

Products

Audio	www.ti.com/audio
Amplifiers	amplifier.ti.com
Data Converters	dataconverter.ti.com
DLP® Products	www.dlp.com
DSP	dsp.ti.com
Clocks and Timers	www.ti.com/clocks
Interface	interface.ti.com
Logic	logic.ti.com
Power Mgmt	power.ti.com
Microcontrollers	microcontroller.ti.com
RFID	www.ti-rfid.com
OMAP Applications Processors	www.ti.com/omap
Wireless Connectivity	www.ti.com/wirelessconnectivity

Applications

Automotive and Transportation	www.ti.com/automotive
Communications and Telecom	www.ti.com/communications
Computers and Peripherals	www.ti.com/computers
Consumer Electronics	www.ti.com/consumer-apps
Energy and Lighting	www.ti.com/energy
Industrial	www.ti.com/industrial
Medical	www.ti.com/medical
Security	www.ti.com/security
Space, Avionics and Defense	www.ti.com/space-avionics-defense
Video and Imaging	www.ti.com/video

TI E2E Community

e2e.ti.com