

DP83TG720R-Q1 1000BASE-T1 Automotive Ethernet PHY

1 Features

- IEEE802.3bp 1000BASE-T1 compliant
- Open Alliance TC12 Interoperability and EMC compliant
 - Interoperability tested with OA/IEEE compliant PHYs
 - EMC immunity Class-IV compliant for UTP (unshielded twisted pair)
- Integrated LPF on MDI pins
- MAC Interface: RGMII
- Supported I/O voltages: 3.3 V, 2.5 V, and 1.8 V
- Pin compatible with TI's 100BASE-T1 PHY
 - Single board design for 100BASE-T1 and 1000BASE-T1 with required BOM change
- Power savings features:
 - standby and sleep
 - local and remote wake-up
- Diagnostic tool kit
 - high accuracy temperature monitor
 - voltage monitor
 - ESD event monitor
 - Data throughput calculator : inbuilt MAC packet generator, counter and error checker
 - link quality monitoring
 - cable open and short fault detection
 - loopback modes
- 25MHz clock output source
- VQFN, wettable flank packaging
- AEC-Q100 Qualified
 - Inbuilt ESD protection : IEC61000-4-2 ESD : ±8-kV contact discharge
 - Device temperature grade 1: –40°C to +125°C ambient operating temperature

2 Applications

- Telematics control unit (TCU, TBOX)
- Gateway and body control
- ADAS: LIDAR, RADAR, Front Camera

3 Description

The DP83TG720R-Q1 device is an IEEE 802.3bp and Open Alliance compliant automotive Ethernet physical layer transceiver. It provides all physical layer functions needed to transmit and receive data over unshielded/shielded single twisted-pair cables. The device supports RGMII for interfacing with a MAC.

DP83TG720 is compliant to Open Alliance EMC and interoperable specifications over unshielded twisted cable. DP83TG720 is pin-2-pin compatible to TI's 100Base-T1 PHY enabling design scalability with single board for both speeds. This device offers the Diagnostic Tool Kit, with an extensive list of real-time monitoring tools, debug tools and test modes. Within the tool kit is the first integrated electrostatic discharge (ESD) monitoring tool. It is capable of counting ESD events on both the xMII and MDI as well as providing real-time monitoring through the use of a programmable interrupt. Additionally, the DP83TG720R-Q1 includes a data generator and checker tool to generate customizable MAC packets and check the errors on incoming packets. This enables system level datapath tests/optimizations without dependency on MAC.

Device Information⁽¹⁾

PART NUMBER	PACKAGE	BODY SIZE (NOM)
DP83TG720R-Q1	VQFN (36)	6.00 mm × 6.00 mm

(1) For all available packages, see the orderable addendum at the end of the data sheet.

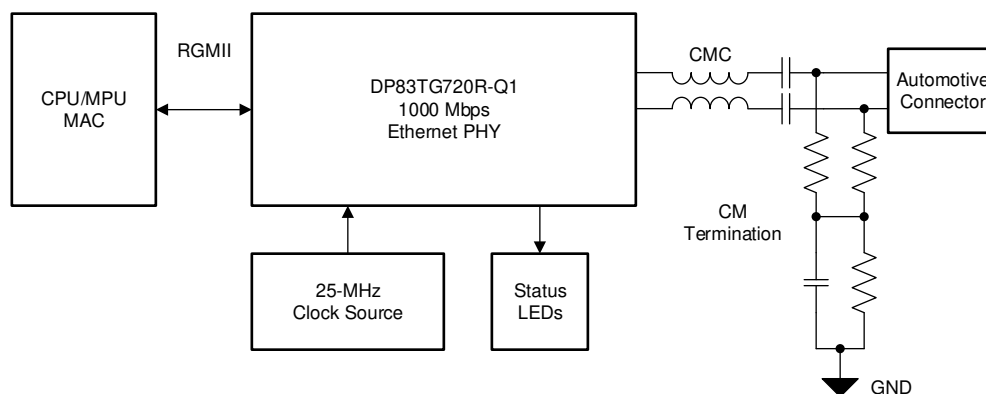

Figure 3-1. Simplified Schematic



Table of Contents

1 Features	1	8.3 Feature Description.....	24
2 Applications	1	8.4 Device Functional Modes.....	40
3 Description	1	8.5 Programming.....	54
4 Revision History	2	8.6 Register Maps.....	58
5 Device Comparison Table	3	9 Application and Implementation	112
6 Pin Configuration and Functions	4	9.1 Application Information.....	112
Pin Functions.....	5	9.2 Typical Applications.....	112
7 Specifications	9	10 Power Supply Recommendations	114
7.1 Absolute Maximum Ratings	9	11 Compatibility with TI's 100BT1 PHY	117
7.2 ESD Ratings	9	12 Layout	118
7.3 Recommended Operating Conditions	10	12.1 Layout Guidelines.....	118
7.4 Thermal Information	10	13 Device and Documentation Support	120
7.5 Electrical Characteristics	10	13.1 Receiving Notification of Documentation Updates.....	120
7.6 Timing Requirements	13	13.2 Support Resources.....	120
7.7 Timing Diagrams.....	17	13.4 Electrostatic Discharge Caution.....	120
7.8 LED Drive Characteristics.....	21	13.5 Glossary.....	120
8 Detailed Description	22	14 Mechanical, Packaging, and Orderable Information	121
8.1 Overview.....	22	14.1 Package Option Addendum.....	121
8.2 Functional Block Diagram.....	23		

4 Revision History

NOTE: Page numbers for previous revisions may differ from page numbers in the current version.

Changes from Revision A (February 2021) to Revision B (March 2021)	Page
• IOZ, 2 level boot-strap's Mode 2 threshold and Rpull-down min/max datasheet limits updated to give more margin to customer application.....	9
• Min/Max values of rgmii DLL_TX_DELAY, sleep mode timing parameters, latency parameters, reset mode power, standby mode power and sleep mode power added	9
• Changed Integrated Pull-Down Resistance from 4.5 kΩ to 4.725 kΩ.....	9
• Further details added to remote sleep exit procedure.....	43
• Note added for more margins for 1.8V two level straps.....	54
• Updated Power Supply Recommendation Note.....	114

Changes from Revision * (December 2020) to Revision A (February 2021)	Page
• Pull-down resistor value of rx_cntrl and strp_1 pins in pin-state tables updated from 6 K to 6.3 K to match exact value in specification	5
• SQI section updated to meet OA requirements.....	24
• Strap circuit diagram updated to remove external pull-down.....	54
• Register map enhanced with added description.....	58

5 Device Comparison Table

PART NUMBER	RGMII SUPPORT	SGMII SUPPORT	OPERATING TEMPERATURE
DP83TG720R-Q1	Yes	No	–40°C to 125°C
DP83TG720S-Q1	Yes	Yes	–40°C to 125°C

6 Pin Configuration and Functions

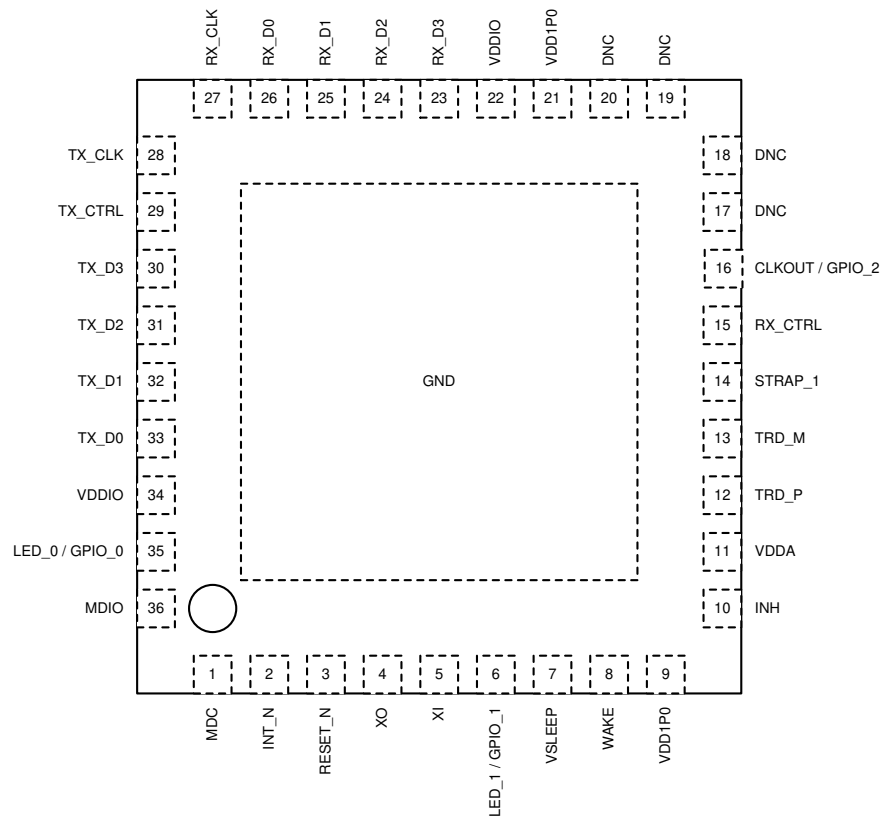

Figure 6-1. RHA Package 36-Pin VQFN Top View

Pin Functions

PIN		STATE ⁽¹⁾	DESCRIPTION
NAME	NO.		
MAC INTERFACE			
RX_D3	23	S, PD, O	Receive Data: Symbols received on the cable are decoded and transmitted out of these pins synchronous to the rising edge of RX_CLK. They contain valid data when RX_DV(decoded from RX_CTL) is asserted. A nibble, RX_D[3:0], is transmitted in RGMII mode.
RX_D2	24		
RX_D1	25		
RX_D0	26		
RX_CLK	27	O	Receive Clock: In RGMII mode, PHY provides this 125-MHz clock to MAC.
RX_CTRL	15	S, PD, O	RGMII Receive Control: Receive control combines receive data valid indication and receive error indication into a single signal. RX_DV is presented on the rising edge of RX_CLK and RX_ER is presented on the falling edge of RX_CLK.
TX_CLK	28	I	Transmit Clock: In RGMII mode, MAC provides this 125-MHz clock to PHY.
TX_CTRL	29	I	RGMII Transmit Control: Transmit control combines transmit enable and transmit error indication into a single signal. TX_EN is presented prior to the rising edge of TX_CLK; TX_ER is presented on the falling edge of TX_CLK.
TX_D3	30	I	Transmit Data: In RGMII mode, the transmit data nibble, TX_D[3:0], is received from the MAC .
TX_D2	31		
TX_D1	32		
TX_D0	33		
SERIAL MANAGEMENT INTERFACE			
MDC	1	I	Management Data Clock: Synchronous clock to the MDIO serial management input and output data.
MDIO	36	OD, IO	Management Data Input/Output: Bidirectional management data signal that may be sourced by the management station or the PHY. This pin requires an external pull-up resistor (recommended value = 2.2-kΩ) .
CONTROL INTERFACE			
$\overline{\text{INT}}$	2	PU, OD, O	Interrupt: Active-LOW output, which will be asserted LOW when an interrupt condition occurs. This pin has a weak internal pullup. Register access is necessary to enable various interrupt triggers. Once an interrupt event flag is set, register access is required to clear the interrupt event on this pin. This pin can be configured as an Active-HIGH output using register[0x0011].
RESET	3	PU, I	RESET: Active-LOW input, which initializes or reinitializes the DP83TG720R-Q1. Asserting this pin LOW for at least 10 μ s will force a reset process to occur. All internal registers will reinitialize to their default states as specified for each bit in the Register Map section. All bootstrap pins are resampled upon deassertion of reset.
INH	10	PMOS OD	INH: Active-HIGH PMOS open-drain output. When the PHY enters the sleep state, PHY will release the INH pin to allow an external pull-down resistor (recommended value = 10 k Ω) to pull the line to ground. When in any other state, the INH pin will drive a HIGH state to the VSLEEP rail.
WAKE	8	PD, I	WAKE: Active-HIGH (this pin works on VSLEEP domain) pulse on wake-up pin wakes up the PHY from the sleep state. For pulse width, refer to timing section. This pin can be directly tied to the VSLEEP rail when the sleep state is not used or left float.
STRP_1	14	PD, I	Strap 1: This pin is for strapping PHY_AD bits.
CLOCK INTERFACE			
XI	5	I	Reference Clock Input: Reference clock 25-MHz \pm 100 ppm-tolerance crystal or oscillator input. The device supports either an external crystal resonator connected across pins XI and XO, or an external CMOS-level oscillator connected to pin XI only and XO left floating.
XO	4	O	Reference Clock Output: XO pin is used for crystal only. This pin should be left floating when a CMOS-level oscillator is connected to XI.
LED/GPIO INTERFACE			
LED_0 / GPIO_0	35	S, PD, IO	LED_0: Link Status

DP83TG720R-Q1

SNLS603B – DECEMBER 2020 – REVISED MARCH 2021

PIN		STATE ⁽¹⁾	DESCRIPTION
NAME	NO.		
LED_1 / GPIO_1	6	S, PD, IO	LED_1: Link Status and BLINK for TX/RX Activity
CLKOUT / GPIO_2	16	IO	Clock Output: 25-MHz reference clock(buffered replication of XI) by default. If not used, clock output can be disabled by writing register 0x0453 = 0x0006.
MEDIUM DEPENDENT INTERFACE			
TRD_M	13	IO	Differential Transmit and Receive: Bidirectional differential signaling configured for 1000BASE-T1 operation, IEEE 802.3bp compliant.
TRD_P	12		
POWER AND GROUND CONNECTIONS			
VDDA3P3	11	SUPPLY	Core Supply: 3.3 V. Refer to power supply recommendations for decoupling network.
VDDIO	22, 34	SUPPLY	IO Supply: 1.8 V, 2.5 V, or 3.3 V. Refer to power supply recommendations for decoupling network.
VDD1P0	9, 21	SUPPLY	Core Supply: 1.0 V. Refer to power supply recommendations for decoupling network.
VSLEEP	7	SUPPLY	Sleep Supply: 3.3 V. Refer to power supply recommendations for decoupling network. This pin shall be tied to VDDA3P3 if sleep functionality is not used.
GROUND	DAP	GROUND	Ground
DO NOT CONNECT			
DNC	17, 18, 19, 20	DNC	DNC: Do Not Connect (test structures connected to these pins and should be kept floating to avoid damage or wrong mode entry of PHY)

- (1) Type: I = Input
 O = Output
 IO = Input/Output
 OD = Open Drain
 PD = Internal Pulldown
 PU = Internal Pullup
 S = Strap: Configuration pin (all configuration pins have weak internal pullups or pulldowns)

Table 6-1. Pin States - RGMII

PIN NAME	POWER-UP / RESET			NORMAL OPERATION - RGMII		
	PIN STATE	PULL TYPE	PULL VALUE (kΩ)	PIN STATE	PULL TYPE	PULL VALUE (kΩ)
MDC	I	none	-	I	none	-
INT_N	I	PU	9	OD	PU	9
RESET_N	I	PU	9	I	PU	9
XO	O	none	-	O	none	-
XI	I	none	-	I	none	-
LED_1	I	PD	9	O	none	-
WAKE	I	PD	50	I	PD	50
STRP_1	I	PD	6.3	I	none	-
INH	I	none	-	PMOS OD, O	none	-
RX_CTRL	I	PD	6.3	O	none	-
CLKOUT/GPIO_2	O	none	-	O	none	-
RX_D3	I	PD	9	O	none	-
RX_D2	I	PD	9	O	none	-
RX_D1	I	PD	9	O	none	-
RX_D0	I	PD	9	O	none	-
RX_CLK	I	PD	9	O	none	-
TX_CLK	I	none	-	I	none	-
TX_CTRL	I	none	-	I	none	-
TX_D3	I	none	-	I	none	-
TX_D2	I	none	-	I	none	-
TX_D1	I	none	-	I	none	-
TX_D0	I	none	-	I	none	-
LED_0	I	PD	9	O	none	-
MDIO	I	none	-	IO	none	-

Table 6-2. Pin States - Sleep and Isolate

PIN NAME	MAC ISOLATE			SLEEP		
	PIN STATE	PULL TYPE	PULL VALUE (kΩ)	PIN STATE	PULL TYPE	PULL VALUE (kΩ)
MDC	I	none	-	Float	none	-
INT_N	O	PU	9	Float	none	-
RESET_N	I	PU	9	Float	none	-
XO	O	none	-	Float	none	-
XI	I	none	-	Float	none	-
LED_1	O	none	-	Float	none	-
WAKE	I	PD	50	I	none	50
STRP_1	I	none	-	Float	none	-
INH	I	none	-	PMOS OD, O	none	-
RX_CTRL	I	PD	6.3	Float	none	-
CLKOUT/GPIO_2	O	none	-	Float	none	-
RX_D3	I	PD/none ⁽¹⁾	9	Float	none	-
RX_D2	I	PD/none ⁽¹⁾	9	Float	none	-
RX_D1	I	PD	9	Float	none	-
RX_D0	I	PD	9	Float	none	-
RX_CLK	I	PD	9	Float	none	-
TX_CLK	I	none	-	Float	none	-
TX_CTRL	I	none	-	Float	none	-
TX_D3	I	none	-	Float	none	-
TX_D2	I	none	-	Float	none	-
TX_D1	I	none	-	Float	none	-
TX_D0	I	none	-	Float	none	-
LED_0	O	none	-	Float	none	-
MDIO	IO	none	-	Float	none	-

(1) PD only for Rgmii's isolate mode.

Note

For sleep mode entry vdda, vddio and vdd1p0 are supposed to be powered-down. See figure Required Implementation of Sleep Mode for further details.

7 Specifications

7.1 Absolute Maximum Ratings

over operating free-air temperature range (unless otherwise noted)⁽¹⁾

		MIN	TYP	MAX	UNIT
Supply Voltage	VDDA3P3	-0.5		4	V
Supply Voltage	VDD1P0	-0.5		1.4	V
Supply Voltage	VDDIO (3.3V)	-0.5		4	V
Supply Voltage	VDDIO (2.5V)	-0.5		2.9	V
Supply Voltage	VDDIO (1.8V)	-0.5		2.2	V
Supply Voltage	V _{SLEEP}	-0.5		4	V
MDI Pins	TRD_M, TRD_P	-0.5		4	V
LVC MOS/ LV TTL Input Voltage	MDC, $\overline{\text{RESET}}$, XI, LED_1, STRP_1, RX_CTRL, CLKOUT, RX_D[3:0], TX_CLK, TX_CTRL, TX_D[3:0], LED_0, MDIO	-0.5		VDDIO + 0.3	V
LVC MOS/ LV TTL Input Voltage	WAKE	-0.5		V _{SLEEP} + 0.3	V
LVC MOS/ LV TTL Output Voltage	$\overline{\text{INT}}$, LED_1, RX_CTRL, CLKOUT, RX_D[3:0], RX_CLK, LED_0, MDIO	-0.5		VDDIO + 0.3	V
LVC MOS/ LV TTL Output Voltage	INH	-0.5		V _{SLEEP} + 0.3	V
T _J	Junction Temperature			150	°C
T _{stg}	Storage temperature	-65		150	°C

- (1) Stresses beyond those listed under *Absolute Maximum Rating* may cause permanent damage to the device. These are stress ratings only, which do not imply functional operation of the device at these or any other conditions beyond those indicated under *Recommended Operating Condition*. Exposure to absolute-maximum-rated conditions for extended periods may affect device reliability.

7.2 ESD Ratings

				VALUE	UNIT
V _(ESD)	Electrostatic discharge	Human body model (HBM), per AEC Q100-002 ⁽¹⁾	All pins	±2000	V
V _(ESD)	Electrostatic discharge	Human body model (HBM), per AEC Q100-002 ⁽¹⁾	TRD_M, TRD_P	±8000	V
V _(ESD)	Electrostatic discharge	Charged device model (CDM), per AEC Q100-011	All pins	±500	V
V _(ESD)	Electrostatic discharge	IEC 61000-4-2 contact discharge	TRD_M, TRD_P	±8000	V

- (1) AEC Q100-002 indicates that HBM stressing shall be in accordance with the ANSI/ESDA/JEDEC JS-001 specification.

7.3 Recommended Operating Conditions

over operating free-air temperature range (unless otherwise noted)

		MIN	NOM	MAX	UNIT
VDDIO	IO Supply Voltage, 1.8V operation	1.62	1.8	1.98	V
	IO Supply Voltage, 2.5V operation	2.25	2.5	2.75	
	IO Supply Voltage, 3.3V operation	2.97	3.3	3.63	
VDDA3P3	Core Supply Voltage, 3.3V	2.97	3.3	3.63	V
VDDA1P0	Core Supply Voltage, 1.0V	0.95	1	1.1	V
V _{SLEEP}	Sleep Supply Voltage, 3.3V	2.97	3.3	3.63	V
T _A	Ambient temperature	-40		125	°C

7.4 Thermal Information

THERMAL METRIC ⁽¹⁾		DP83TG720	UNIT
		RHA (VQFN)	
		36 PINS	
R _{θJA}	Junction-to-ambient thermal resistance	32.5	°C/W
R _{θJC(top)}	Junction-to-case (top) thermal resistance	22.2	°C/W
R _{θJB}	Junction-to-board thermal resistance	13.3	°C/W
Ψ _{JT}	Junction-to-top characterization parameter	0.3	°C/W
Ψ _{JB}	Junction-to-board characterization parameter	13.3	°C/W
R _{θJC(bot)}	Junction-to-case (bottom) thermal resistance	3.2	°C/W

(1) For more information about traditional and new thermal metrics, see the [Semiconductor and IC Package Thermal Metrics](#) application report.

7.5 Electrical Characteristics

Over operating free-air temperature range (unless otherwise noted)⁽¹⁾

PARAMETER		TEST CONDITIONS	MIN	TYP	MAX	UNIT
DC CHARACTERISTICS						
XI						
V _{IH}	High-level Input Voltage		1.3			V
V _{IL}	Low-level Input Voltage				0.5	V
WAKE pin	WAKE pin	WAKE pin	WAKE pin	WAKE pin	WAKE pin	WAKE pin
V _{IH}	High-level Input Voltage	V _{SLEEP} = 3.3V ± 10%	2			V
V _{IL}	Low-level Input Voltage	V _{SLEEP} = 3.3V ± 10%			0.8	V
INH pin	INH pin	INH pin	INH pin	INH pin	INH pin	INH pin
V _{OH}	High-level Output Voltage	I _{OH} = -2mA, V _{SLEEP} = 3.3V ± 10%	2.4			V
3.3V VDDIO ⁽²⁾						
V _{OH}	High-level Output Voltage	I _{OH} = -2mA, VDDIO = 3.3V ± 10%	2.4			V
V _{OL}	Low-level Output Voltage	I _{OL} = 2mA, VDDIO = 3.3V ± 10%			0.4	V
V _{IH}	High-level Input Voltage	VDDIO = 3.3V ± 10%	2			V
V _{IL}	Low-level Input Voltage	VDDIO = 3.3V ± 10%			0.8	V
2.5V VDDIO ⁽²⁾						
V _{OH}	High-level Output Voltage	I _{OH} = -2mA, VDDIO = 2.5V ± 10%	2			V
V _{OL}	Low-level Output Voltage	I _{OL} = 2mA, VDDIO = 2.5V ± 10%			0.4	V
V _{IH}	High-level Input Voltage	VDDIO = 2.5V ± 10%	1.7			V
V _{IL}	Low-level Input Voltage	VDDIO = 2.5V ± 10%			0.7	V

Over operating free-air temperature range (unless otherwise noted)⁽¹⁾

PARAMETER		TEST CONDITIONS	MIN	TYP	MAX	UNIT
1.8V VDDIO (2)						
V _{OH}	High-level Output Voltage	I _{OH} = -2mA, VDDIO = 1.8V ± 10%	VDDIO – 0.45			V
V _{OL}	Low-level Output Voltage	I _{OL} = 2mA, VDDIO = 1.8V ± 10%			0.45	V
V _{IH}	High-level Input Voltage	VDDIO = 1.8V ± 10%	0.7 * VDDIO			V
V _{IL}	Low-level Input Voltage	VDDIO = 1.8V ± 10%		0.3 * VDDIO		V
I _{IH}	Input High Current (MDIO)	VIN = VCC, -40°C to 125°C	-5		5	µA
I _{IH}	Input High Current (RGMII Input pin, MDC)	VIN = VCC, -40°C to 125°C	-20		20	µA
I _{OZ}	Input High Current (MDIO)	VIN swept from 0V till VCC, -40°C to 125°C	-40		40	µA
I _{IL}	Input Low Current (RGMII Input pin, MDC, MDIO)	VIN = GND, -40°C to 125°C	-40		5	µA
I _{OZL}		INH			6	µA
I _{OZ}	Tri-state Output Current (5)	VIN swept from 0V till VCC, -40°C to 125°C	-40		10	µA
I _{OZ}	Tri-state Output Current (6)	VIN swept from 0V till VCC, -40°C to 125°C	-60		60	µA
C _{IN}	Input Capacitance	LVC MOS/LVTTL pins (3)			2	pF
C _{IN}	Input Capacitance	LVC MOS/LVTTL pins (4)			4	pF
		XI			1	pF
C _{OUT}	Output Capacitance	LVC MOS/LVTTL pins (3)			2	pF
C _{OUT}	Output Capacitance	LVC MOS/LVTTL pins (4)			4	pF
		XO			1	pF
R _{pull-up}	Integrated Pull-Up Resistance	INT, RESET	6.5	9	12.5	kΩ
R _{pull-down}	Integrated Pull-Down Resistance	STRP_1, RX_CTRL	4.725	6.3	7.875	kΩ
R _{pull-down}	Integrated Pull-Down Resistance	LED_1, RX_D[3:0], RX_CLK, LED_0	7.3	9	13	kΩ
		WAKE	35	50	62.5	kΩ
R _{pull-down}	Integrated Pull-Up Resistance when Active	INH		106		Ω
R _{series}	Integrated MAC Series Termination Resistor (Default)	RX_D[3:0], RX_CTRL, and RX_CLK	24	42	52	Ω
R _{series}	Integrated MAC Series Termination Resistor (with register<0x0456> = 0x0148)	RX_D[3:0], RX_CTRL, and RX_CLK	30	52	65	Ω
R _{series}	Integrated MAC Series Termination Resistor (with register<0x0456> = 0x0168)	RX_D[3:0], RX_CTRL, and RX_CLK	40	70	84	Ω
CURRENT CONSUMPTION, SLEEP MODE						
I _{SLEEP}	Sleep Supply Current	V _{SLEEP}		485	840	µA
CURRENT CONSUMPTION, RESET ASSERTED						
I _{DDIO}	IO Supply Current, VDDIO = 1.8V	VDDIO		4	9	mA
I _{DDIO}	IO Supply Current, VDDIO = 2.5V	VDDIO		5	12	mA
I _{DDIO}	IO Supply Current, VDDIO = 3.3V	VDDIO		6.5	15	mA
I _{DDA3P3}	Core Supply Current, 3.3V	VDDA3P3		5	8	mA
I _{DD1P0}	Core Supply Current, 1.0V	VDD1P0		30	110	mA
CURRENT CONSUMPTION, STANDBY						
I _{DDIO}	IO Supply Current, VDDIO = 1.8V	VDDIO		4	11	mA

Over operating free-air temperature range (unless otherwise noted)⁽¹⁾

PARAMETER		TEST CONDITIONS	MIN	TYP	MAX	UNIT
I _{DDIO}	IO Supply Current, VDDIO = 2.5V	VDDIO		6	13	mA
I _{DDIO}	IO Supply Current, VDDIO = 3.3V	VDDIO		8	15	mA
I _{DDA3P3}	Core Supply Current, 3.3V	VDDA3P3		16	18	mA
I _{DD1P0}	Core Supply Current, 1.0V	VDD1P0		33	112	mA
CURRENT CONSUMPTION, ACTIVE MODE, Voltage: +/- 10%, Traffic : 100%,Packet Size: 1518, Content : Random						
I _{DDIO}	IO Supply Current, VDDIO = 1.8V	RGMII		20	25	mA
I _{DDIO}	IO Supply Current, VDDIO = 2.5V	RGMII		26	30	mA
I _{DDIO}	IO Supply Current, VDDIO = 3.3V	RGMII		33	40	mA
I _{DDA3P3}	Core Supply Current, 3.3V	RGMII		85	89	mA
I _{DD1P0}	Core Supply Current, 1.0V	RGMII		177	250	mA
I _{SLEEP}	Sleep Supply Current	V _{SLEEP} = 3.3V +/- 10%		1000	1500	µA
MDI CHARACTERISTICS						
V _{OD-MDI}	Output Differential Voltage	R _{L(diff)} = 100 Ω			1.3	V
R _{MDI-DIFF}	Integrated Differential MDI Termination (Active State)	TRD_P, TRD_M		100		Ω
R _{MDI-DIFF}	Integrated Differential MDI Termination (Sleep State)	TRD_P, TRD_M		100		Ω
BOOTSTRAP DC CHARACTERISTICS						
2 level straps						
V _{bs1_1v8}	Bootstrap Threshold	Mode 1, VDDIO = 1.8V ± 10%, 2-level	0	0.35*VD DIO		V
V _{bsh_1v8}	Bootstrap Threshold	Mode 2, VDDIO = 1.8V ± 10%, 2-level	1.175	VDDIO		V
V _{bs1_2v5}	Bootstrap Threshold	Mode 1, VDDIO = 2.5V ± 10%, 2-level	0	0.7		V
V _{bsh_2v5}	Bootstrap Threshold	Mode 2, VDDIO = 2.5V ± 10%, 2-level	1.175	VDDIO		V
V _{bs1_3v3}	Bootstrap Threshold	Mode 1, VDDIO = 3.3V ± 10%, 2-level	0	0.7		V
V _{bsh_3v3}	Bootstrap Threshold	Mode 2, VDDIO = 3.3V ± 10%, 2-level	1.175	VDDIO		V
3 level straps						
V _{bs1_1v8}	Bootstrap Threshold	Mode 1, VDDIO = 1.8V ± 10%, 3-level	0	0.35 * VDDIO		V
V _{bs2_1v8}	Bootstrap Threshold	Mode 2, VDDIO = 1.8V ± 10%, 3-level	0.40 * VDDIO	0.75 * VDDIO		V
V _{bs3_1v8}	Bootstrap Threshold	Mode 3, VDDIO = 1.8V ± 10%, 3-level	0.84 * VDDIO	VDDIO		V
V _{bs1_2v5}	Bootstrap Threshold	Mode 1, VDDIO = 2.5V ± 10%, 3-level	0	0.19 * VDDIO		V
V _{bs2_2v5}	Bootstrap Threshold	Mode 2, VDDIO = 2.5V ± 10%, 3-level	0.27 * VDDIO	0.41 * VDDIO		V
V _{bs3_2v5}	Bootstrap Threshold	Mode 3, VDDIO = 2.5V ± 10%, 3-level	0.58 * VDDIO	VDDIO		V
V _{bs1_3v3}	Bootstrap Threshold	Mode 1, VDDIO = 3.3V ± 10%, 3-level	0	0.18 * VDDIO		V
V _{bs2_3v3}	Bootstrap Threshold	Mode 2, VDDIO = 3.3V ± 10%, 3-level	0.22 * VDDIO	0.42 * VDDIO		V
V _{bs3_3v3}	Bootstrap Threshold	Mode 3, VDDIO = 3.3V ± 10%, 3-level	0.46 * VDDIO	VDDIO		V
Temperature Sensor						

Over operating free-air temperature range (unless otherwise noted)⁽¹⁾

PARAMETER		TEST CONDITIONS	MIN	TYP	MAX	UNIT
	Temperature Sensor Resolution (LSB)	-40°C to 125°C		1.5		°C
	Temperature Sensor Accuracy (Voltage and Temperature Variation on single part)	-40°C to 125°C	-7.5		7.5	°C
	Temperature Sensor Accuracy (Voltage, Temperature and Part-to-Part variation)	-40°C to 125°C	-21.5		20	°C
	Temperature Sensor Range		-40		140	°C
Voltage Sensor						
	VDDA3P3 Sensor Range		2.66	3.3	3.96	V
	VDDA3P3 Sensor Resolution (LSB)	-40°C to 125°C		8.6		mV
	VDDA3P3 Sensor Accuracy (Voltage and Temperature Variation)	-40°C to 125°C		8.6		mV
	VDDA3P3 Sensor Accuracy Part-to-Part	-40°C to 125°C	-68.8		68.8	mV
	VDD1P0 Sensor Range		0.8		1.2	V
	VDD1P0 Sensor Resolution (LSB)	-40°C to 125°C		2.8		mV
	VDD1P0 Sensor Accuracy (Voltage and Temperature Variation)	-40°C to 125°C		2.8		mV
	VDD1P0 Sensor Accuracy Part-to-Part	-40°C to 125°C	-22.4		22.4	mV
	VDDIO Sensor Range		1.44		3.8	V
	VDDIO Sensor Resolution (LSB)	-40°C to 125°C		15.4		mV
	VDDIO Sensor Accuracy (Voltage and Temperature Variation)	-40°C to 125°C		15.4		mV
	VDDIO Sensor Accuracy Part-to-Part	-40°C to 125°C	-78		78	mV

(1) Ensured by production test, characterization or design

(2) For pins: LED_1, STRP_1, RX_CTRL, CLKOUT, RX_D[3:0], RX_CLK, LED_0

(3) For pins: MDC, INT, RESET, LED_1, STRP_1, RX_CTRL, CLKOUT, RX_D0, RX_D1, RX_CLK, TX_CLK, TX_CTRL, TX_D2, TX_D3, LED_0, and MDIO

(4) For pins: TX_D0, TX_D1, RX_D2, and RX_D3

(5) For pins : LED_1, RX_D[3:0], RX_CLK, LED_0

(6) For pins : STRP_1 and RX_CTRL

7.6 Timing Requirements

(1)

PARAMETER		TEST CONDITIONS	MIN	NOM	MAX	UNIT
POWER-UP TIMING						
T5.1	VDDA3P3 Duration ⁽²⁾	0% to 100% (+/- 10 VDDA3P3)	0.5		40	ms
T5.2	VDD1P0 Duration ⁽²⁾	0% to 100% (+/- 10 VDD1P0)	0.1		40	ms
T5.2	VDDIO Duration ⁽²⁾	VDDIO = 1.8V	0.1		40	ms
T5.2	VDDIO Duration ⁽²⁾	VDDIO = 2.5V	0.1		40	ms
T5.2	VDDIO Duration ⁽²⁾	VDDIO = 3.3V	0.1		40	ms
T5.2	V _{SLEEP} Duration ⁽²⁾	0% to 100% (+/- 10 V _{SLEEP})	0.1		40	ms
T5.3	Crystal stabilization-time post power-up (from last power rail ramp to 100%)			1500		µs
T5.4	Oscillator stabilization-time post power-up (from last power rail ramp to 100%) ⁽³⁾				20	ms

(1)

PARAMETER		TEST CONDITIONS	MIN	NOM	MAX	UNIT
T5.5	Post power-up stabilization-time prior to MDC preamble for register access		65			ms
T5.6	Hardware configuration latch-in time from power-up				60	ms
T5.7	Hardware configuration pins transition to functional mode from latch-in completion				110	ns
T5.8	PAM3 IDLE Stream from power-up (Master Mode)				60	ms
RESET TIMING (RESET_N)						
T6.1	RESET pulse width		5			µs
T6.2	Post reset stabilization-time prior to MDC preamble for register access		1			ms
T6.3	Hardware configuration latch-in time from reset				2	µs
T6.4	Hardware configuration pins transition to functional mode from latch-in completion				1.5	µs
T6.5	PAM3 IDLE Stream from reset (Master Mode)				1500	µs
SMI TIMING						
T4.1	MDC to MDIO (Output) Delay Time (25 pF load)		0	6	10	ns
T4.2	MDIO (Input) to MDC Setup Time		10			ns
T4.3	MDIO (Input) to MDC Hold Time		10			ns
	MDC Frequency (25 pF load)			2.5	20	MHz
RECEIVE LATENCY TIMING						
	SSD symbol on MDI to Rising edge of RGMII RX_CLK with assertion of RX_CTRL				8	µs
	SSD symbol on MDI to Rising edge of RGMII RX_CLK with assertion of RX_CTRL (RS-FEC bypass mode)				400	ns
TRANSMIT LATENCY TIMING						
	RGMII Rising edge TX_CLK with assertion TX_CTRL to SSD symbol on MDI				0.8	µs
	RGMII Rising edge TX_CLK with assertion TX_CTRL to SSD symbol on MDI (RS-FEC bypass mode)				600	ns
25 MHz OSCILLATOR REQUIREMENTS						
	Frequency (XI)			25		MHz
	Frequency Tolerance and Stability Over temperature and aging		-100		100	ppm
	Rise / Fall Time (10% - 90%) ⁽⁶⁾				8	ns
	Jitter (RMS)	Integrated upto 5MHz			1	ps
	Duty Cycle		40	50	60	%
RGMII TIMING						
T _{setupR}	TX_D[3:0], TX_CTRL Setup to TX_CLK	on PHY pins	1	2		ns
T _{holdR}	TX_D[3:0], TX_CTRL Hold from TX_CLK ⁽⁵⁾	on PHY pins	1	2		ns
T _{skewT}	RX_D[3:0], RX_CTRL Delay from RX_CLK (Align Mode Enabled)	On PHY Pins	-500	0	500	ps
T _{skewT} (Shift)	RX_D[3:0], RX_CTRL Delay from RX_CLK (Shift Mode Enabled, default) ⁽⁴⁾	On PHY Pins	2.240	2.650	2.970	ns
T _{cyc}	Clock Cycle Duration	RX_CLK	7.2	8	8.8	ns
T _{cyc}	Clock Cycle Duration	TX_CLK	7.2	8	8.8	ns
Duty_G	Duty Cycle	RX_CLK	45	50	55	%
Duty_G	Duty Cycle	TX_CLK	45	50	55	%
Tr	Rise Time (20% - 80%)	CL=Ctrace=5pF			0.75	ns

(1)

PARAMETER		TEST CONDITIONS	MIN	NOM	MAX	UNIT
Tf	Fall Time (20% - 80%)	C _L =C _{trace} = 5pF			0.75	ns
RGMII RX Shift Mode Delays	DLL DLL_RX_DELAY_CTRL_SL=0 ⁽⁴⁾		0.330	0.650	0.970	ns
	DLL DLL_RX_DELAY_CTRL_SL=1 ⁽⁴⁾		0.580	0.900	1.220	ns
	DLL DLL_RX_DELAY_CTRL_SL=2 ⁽⁴⁾		0.830	1.150	1.470	ns
	DLL DLL_RX_DELAY_CTRL_SL=3 ⁽⁴⁾		1.000	1.400	1.720	ns
	DLL DLL_RX_DELAY_CTRL_SL=4 ⁽⁴⁾		1.230	1.650	1.970	ns
	DLL DLL_RX_DELAY_CTRL_SL=5 ⁽⁴⁾		1.490	1.990	2.220	ns
	DLL DLL_RX_DELAY_CTRL_SL=6 ⁽⁴⁾		1.690	2.150	2.470	ns
	DLL DLL_RX_DELAY_CTRL_SL=7 ⁽⁴⁾		1.960	2.400	2.730	ns
	DLL DLL_RX_DELAY_CTRL_SL=8 ⁽⁴⁾		2.180	2.650	2.970	ns
	DLL DLL_RX_DELAY_CTRL_SL=9 ⁽⁴⁾		2.490	2.900	3.220	ns
RGMII Shift TX Mode Delays	DLL DLL_TX_DELAY_CTRL_SL=1 ^{(4) (7)}		0.08	0.25	0.38	ns
	DLL DLL_TX_DELAY_CTRL_SL=2 ^{(4) (7)}		0.27	0.49	0.67	ns
	DLL DLL_TX_DELAY_CTRL_SL=3 ^{(4) (7)}		0.51	0.73	0.91	ns
	DLL DLL_TX_DELAY_CTRL_SL=4 ^{(4) (7)}		0.75	0.97	1.15	ns
	DLL DLL_TX_DELAY_CTRL_SL=5 ^{(4) (7)}		0.94	1.21	1.44	ns
	DLL DLL_TX_DELAY_CTRL_SL=6 ^{(4) (7)}		1.18	1.45	1.68	ns
	DLL DLL_TX_DELAY_CTRL_SL=7 ^{(4) (7)}		1.37	1.69	1.98	ns
	DLL DLL_TX_DELAY_CTRL_SL=8 ^{(4) (7)}		1.61	1.93	2.22	ns
	DLL DLL_TX_DELAY_CTRL_SL=9 ^{(4) (7)}		1.85	2.17	2.46	ns
	DLL DLL_TX_DELAY_CTRL_SL=10 ^{(4) (7)}		2.04	2.42	2.75	ns
	DLL DLL_TX_DELAY_CTRL_SL=11 ^{(4) (7)}		2.28	2.65	2.99	ns
	DLL DLL_TX_DELAY_CTRL_SL=12 ^{(4) (7)}		2.52	2.9	3.23	ns
	25 MHz CRYSTAL REQUIREMENTS					
	Frequency			25		MHz
	Frequency Tolerance and Stability Over temperature and aging		-100		100	ppm
	Equivalent Series Resistance				50	Ω
OUTPUT CLOCK TIMING (CLKOUT)						
	Frequency			25		MHz
	Duty Cycle (With crystal attached)		45		55	%
	Rise / Fall Time (10% - 90%)				2.5	ns
	Jitter (RMS) (Slave Mode, MAC linterface : SGMII)				5	ps
	Jitter (RMS) (Master Mode, MAC linterface : SGMII)				2.4	ps
	Jitter (RMS) (Slave Mode, MAC Interface : RGMII)				11	ps
	Jitter (RMS) (Master Mode, MAC Interface : RGMII)				15	ps
Sleep Entry and Wake-Up						
	WAKE LOW to Sleep Entry; INH Transition LOW	Normal Mode, MDI_Energy = FALSE sleep_en = TRUE		64	85	us

(1)

PARAMETER		TEST CONDITIONS	MIN	NOM	MAX	UNIT
	sleep_en = True to Sleep Entry; INH Transition LOW (master mode)	Normal Mode, WAKE = LOW, MDI_Energy = FALSE		5	85	us
	sleep_en = True to Sleep Entry; INH Transition LOW (slave mode)	Normal Mode, WAKE = LOW, MDI_Energy = FALSE			5000	us
	MDI Energy Loss to Sleep Entry; INH Transition LOW	Normal Mode, WAKE = LOW, sleep_en = TRUE			5	ms
	Local Wake-Up Pulse Duration (on Wake pin)	Sleep Mode, WAKE pin	80			µs
	Send-S/Send-T pattern duration for wake up from MDI	Sleep Mode, Slave	1.25			ms
	Local Wake-Up; INH Transition HIGH	Sleep Mode, rising edge of WAKE pin to rising edge of INH			85	us
	Tolerable differential noise level on MDI for PHY to stay in sleep mode	Sleep Mode			200	mV pk-pk
	Link-partner's VOD for valid wake-up (for 5m cable)	Sleep Mode	840			mV pk-pk

- (1) Ensured by production test or characterization or design.
- (2) No supply sequencing constraint across power rails
- (3) In case OSC clock is delayed, additional reset is needed post Osc clock stabilisation
- (4) Refer register[0x0430] for programmability of RX and TX delay codes
- (5) PHY provides internal delays on TX_CLK to TX_D[3:0] to add additional skew upto 2 ns. Refer to register[0x0430] for programmability
- (6) Max rise/fall time of 8ns is supported for duty cycle of 40% to 55%. Max rise/fall time will be 6 ns for duty cycle of 40% to 60%
- (7) Data for 1.8V VDDIO.

7.7 Timing Diagrams

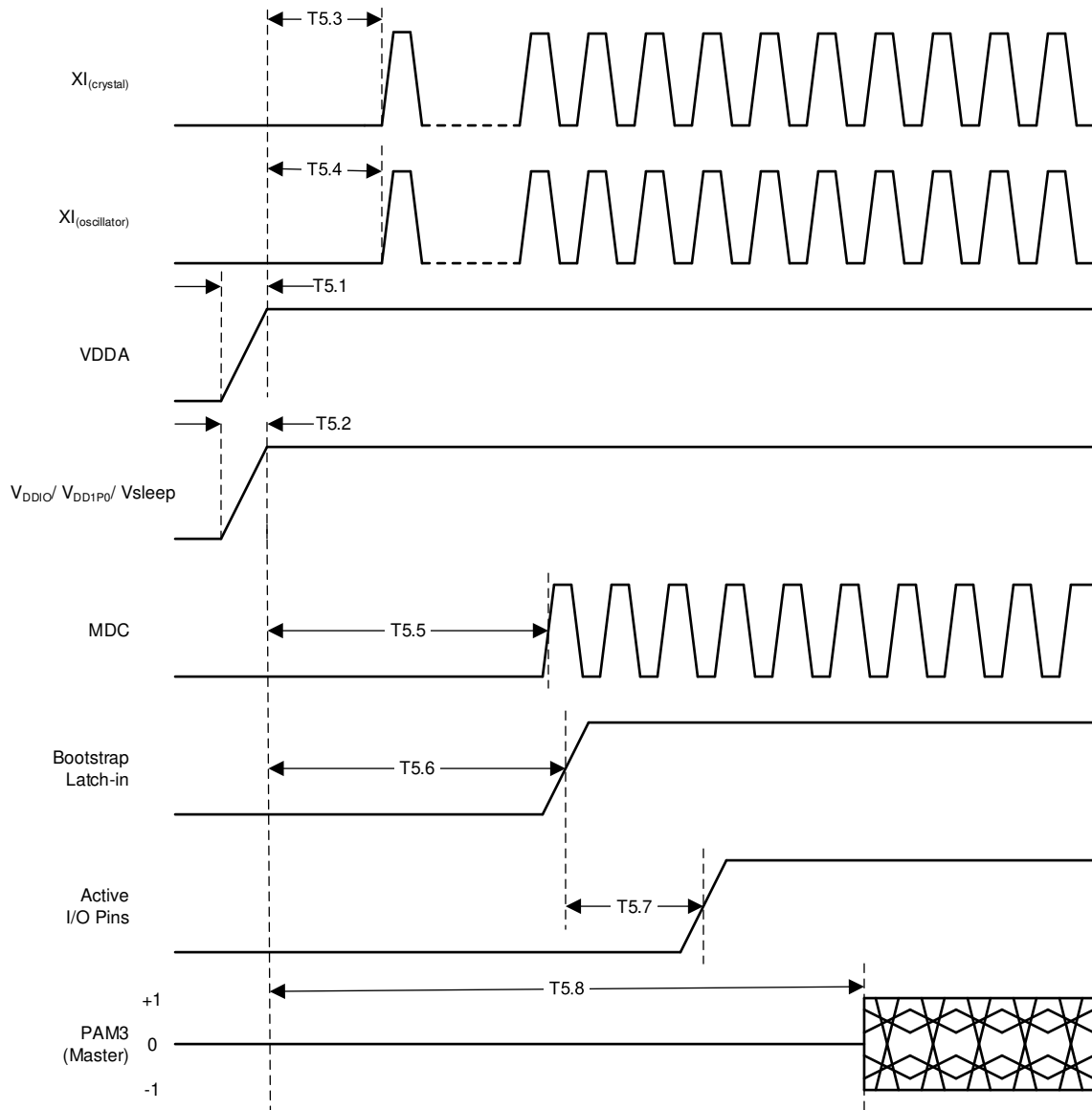

Figure 7-1. Power Up Timing

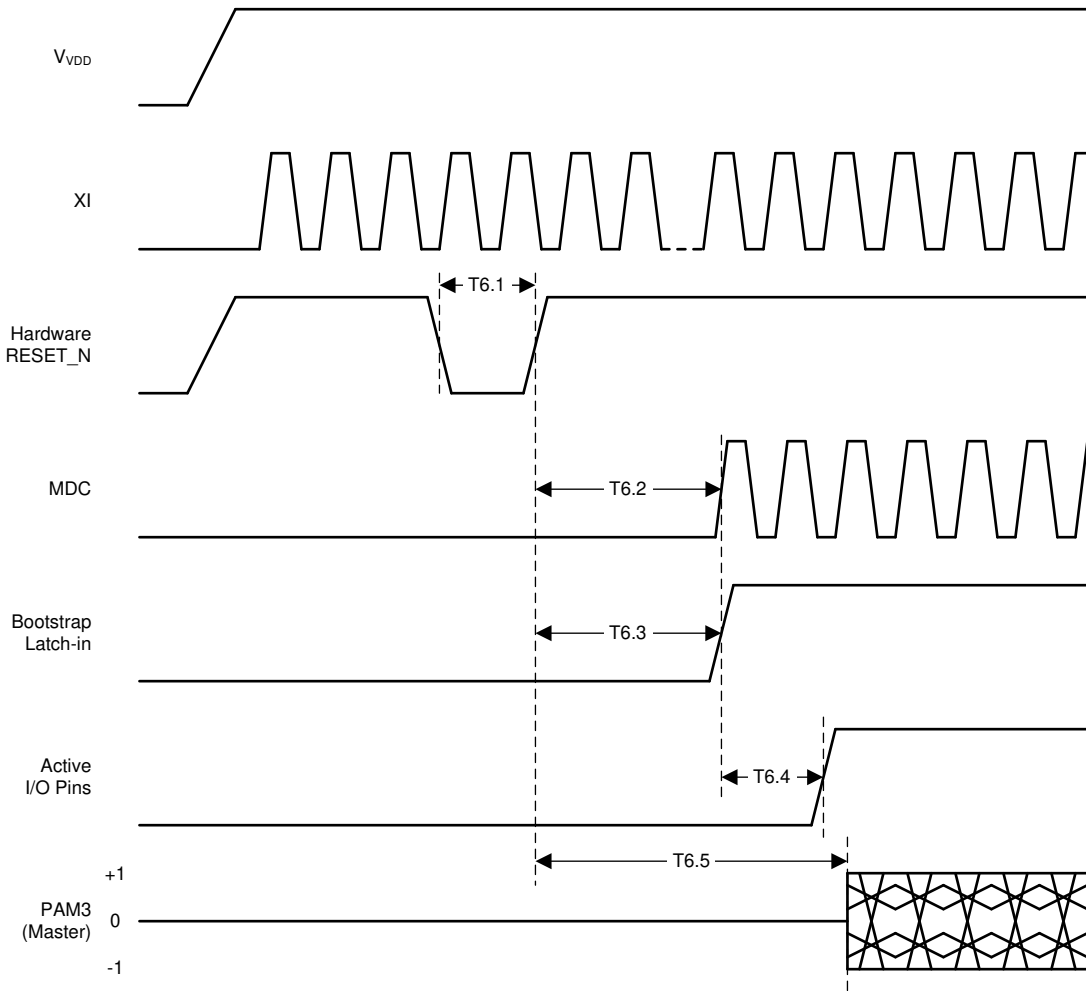

Figure 7-2. Reset Timing

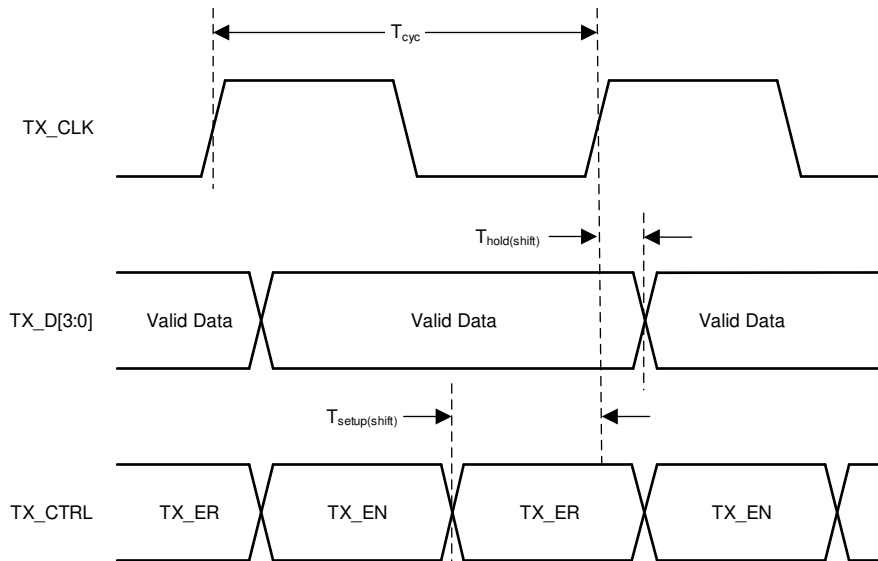

Figure 7-3. RGMII Transmit Timing (Internal Delay Enabled)

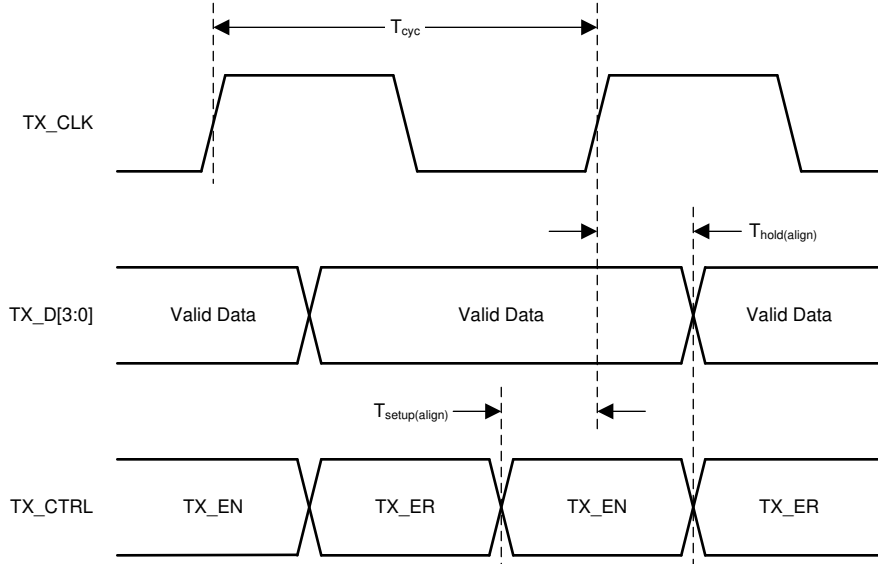

Figure 7-4. RGMII Transmit Timing (Internal Delay Disabled)

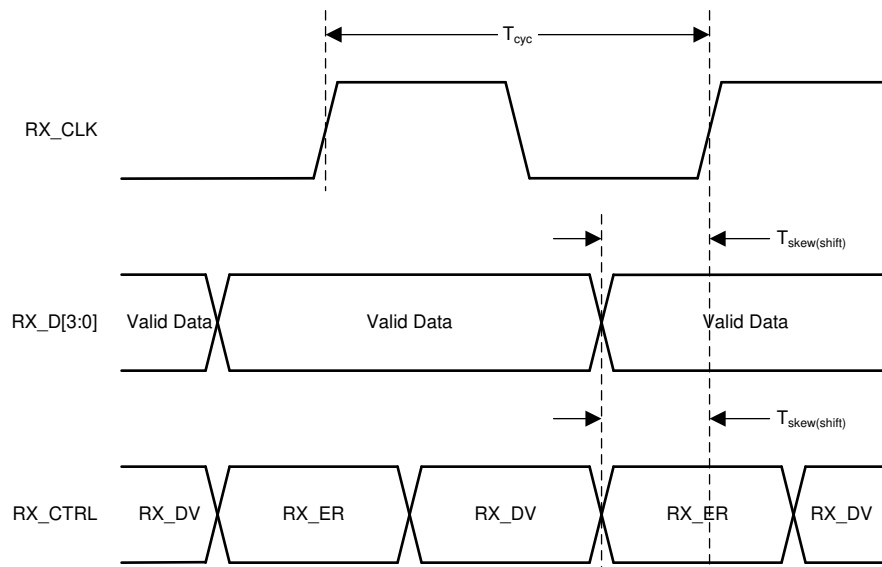

Figure 7-5. RGMII Receive Timing (Internal Delay Enabled)

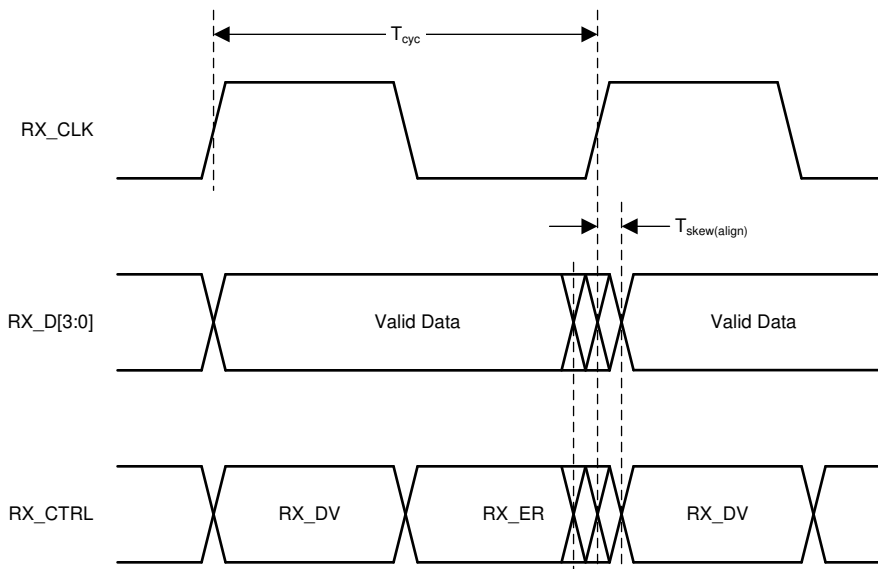

Figure 7-6. RGMII Receive Timing (Internal Delay Disabled)

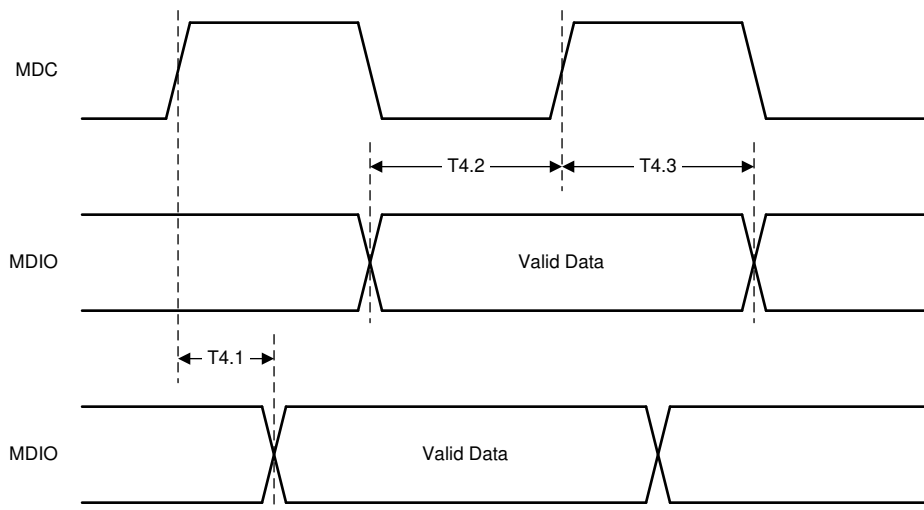

Figure 7-7. Serial Management Timing

7.8 LED Drive Characteristics

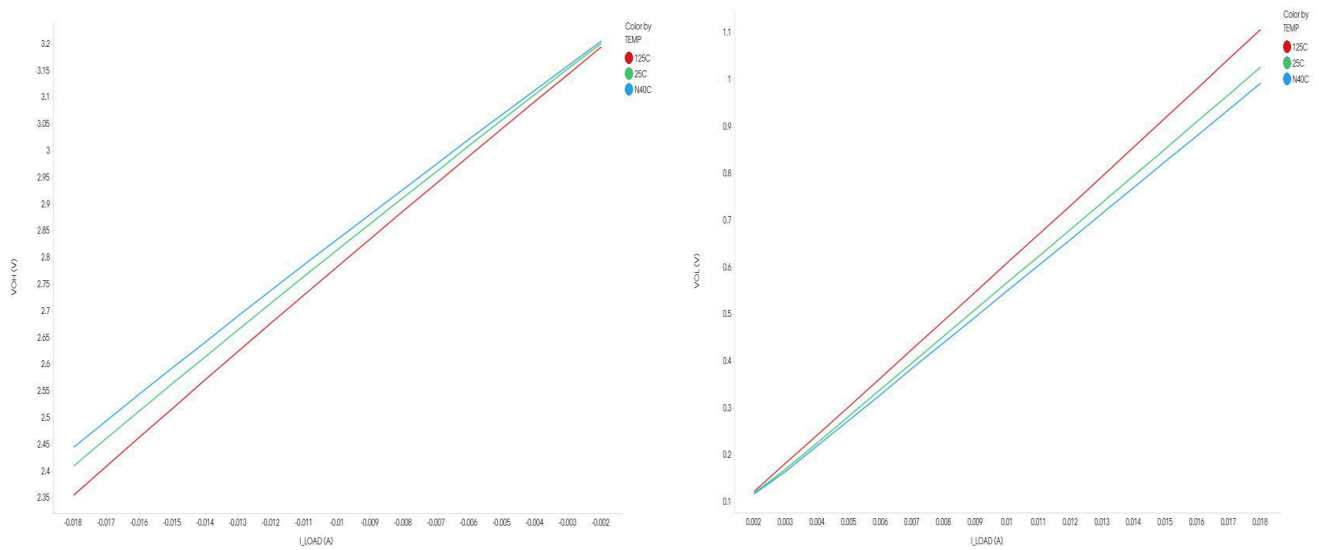

Figure 7-8. LED V vs I for 3.3V VDDIO

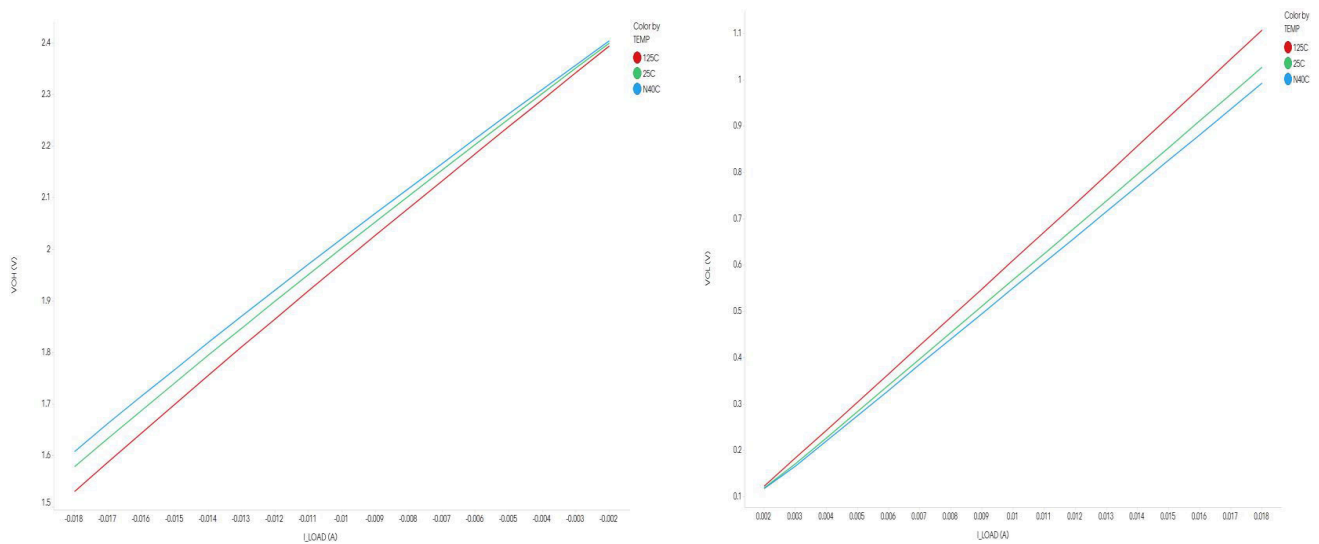

Figure 7-9. LED V vs I for 2.5V VDDIO

8 Detailed Description

8.1 Overview

The DP83TG720R-Q1 is a 1000BASE-T1 automotive Ethernet Physical Layer transceiver. It is IEEE 802.3bp compliant and AEC-Q100 qualified for automotive applications.

This device is specifically designed to operate at 1-Gbps speed while meeting stringent automotive EMC requirements. The DP83TG720R-Q1 transmits PAM3 ternary symbols at 750-MBd over unshielded/shielded single-twisted pair cable. It is designed for RGMII support in a single 36-pin VQFN wettable flank package.

8.2 Functional Block Diagram

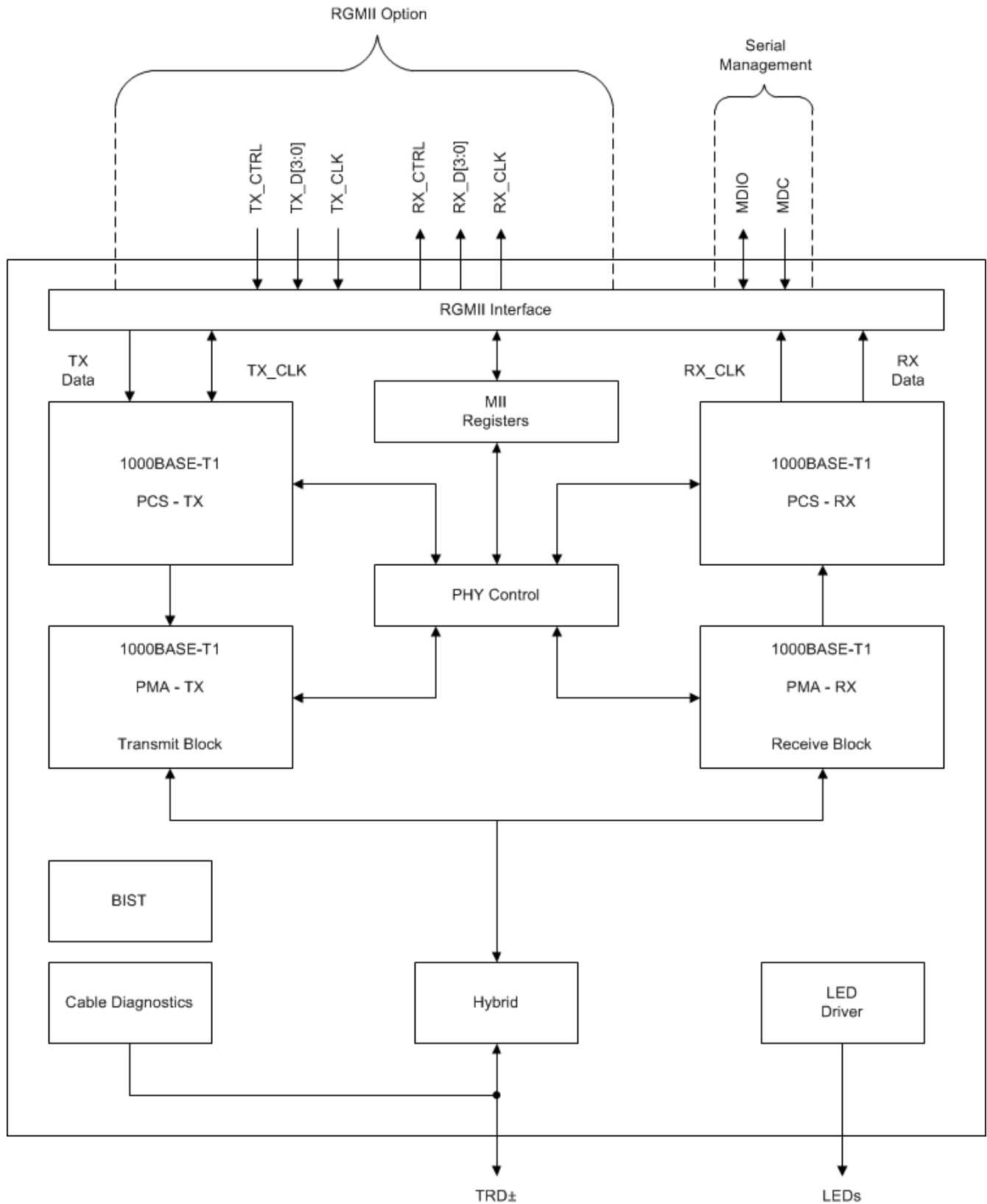

Figure 8-1. DP83TG720R-Q1 Functional Block Diagram

8.3 Feature Description

8.3.1 Diagnostic Tool Kit

The DP83TG720R-Q1 diagnostic tool kit provides mechanisms for monitoring normal operation, device-level debugging, system-level debugging, fault detection, and compliance testing. This tool kit includes a built-in self-test with PRBS data, various loopback modes, Signal Quality Indicator (SQI), Time Domain Reflectometry (TDR), voltage monitor, temperature monitor, electrostatic discharge monitor, and IEEE 802.3bp test modes.

8.3.1.1 Signal Quality Indicator

When the DP83TG720R-Q1 is active, the Signal Quality Indicator may be used to determine the quality of link based on SNR readings made by the device.

SQI is derived based on the calculated SNR value and is presented as five level indication, where level of 4 ensures a BER better than 10^{-10} .

Note

Refer to [DP83TG720: Configuring for Open Alliance Specification Compliance](#) application note for details on using SQI register for Open Alliance TC12 SQI tests.

8.3.1.2 Time Domain Reflectometry

Time domain reflectometry helps detecting and estimating the location of OPEN and SHORT faults along a cable.

TDR is activated by setting bit[15] = 'b1 in the register[0x001E]. When TDR diagnostic process gets completed successfully, Bit[1:0] of register[0x001E] will become 'b10. After this status change, TDR results can be read in the register of following table.

Table 8-1. TDR Result Registers : 0x030F

Register Bits	Description
[1:0]	<ul style="list-style-type: none"> 01 = TDR Activation 10 = TDR On 00,11 = TDR Not Available
[3:2]	Reserved
[7:4]	<ul style="list-style-type: none"> 0011 = Short 0110 = Open 0101 = Noise 0111 = Cable OK 1000 = Test in progress; initial value with TDR ON 1101 = Test not possible (for example, noise, active link) Other values are not valid
[13:8]	<ul style="list-style-type: none"> Fault distance = Value in decimal of [13:8] 'b111111 = Resolution not possible/out of distance
[15:14]	Reserved

Note

TDR should not be run if the link is already active. Running TDR on active line can make TDR fail and also can result in disruption of link.

8.3.1.3 Built-In Self-Test For Datapath

The DP83TG720R-Q1 incorporates a data-path's Built-In-Self-Test (BIST) to check the PHY level and system level data-paths. BIST has following integrated features which make the system level data transfer tests (through-put etc) and diagnostics possible without relying on MAC or external data generator hardware/software.

1. Loopback modes
2. Data generator
 - a. Customizable MAC packets generator.
 - b. Transmitted packet counter.
 - c. PRBS stream generator.
3. Data checker
 - a. Received MAC packets error checker.
 - b. Received packet counter: Counts total packets received and packets received with errors.
 - c. PRBS lock and PRBS error checker.

8.3.1.3.1 Loopback Modes

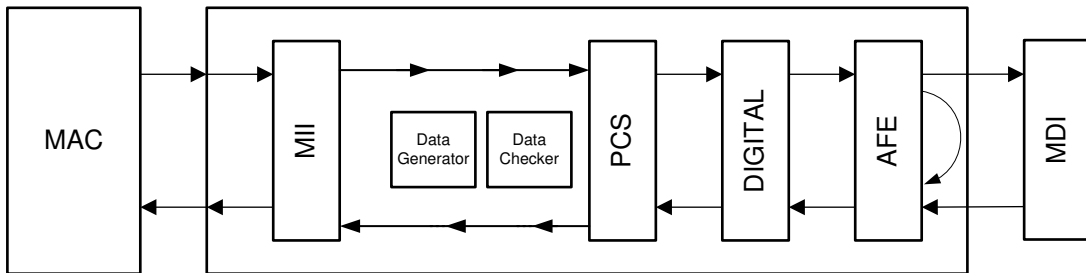

Figure 8-2. All Loopbacks

There are several loopback options within the DP83TG720R-Q1. Enabling different loopback modes enables/ bypass different data-paths according to system verification requirements. Different loopbacks can be enabled along-side following data generation options :

- a. Inbuilt data-generator
- b. External data-generator (on Ethernet cable or MAC side)

Following diagrams illustrate data-flow during different loopback options :

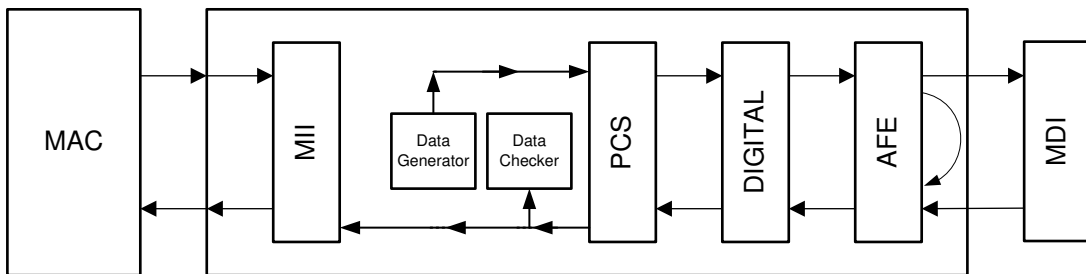

Figure 8-3. Analog Loopback With Inbuilt Data-Gen

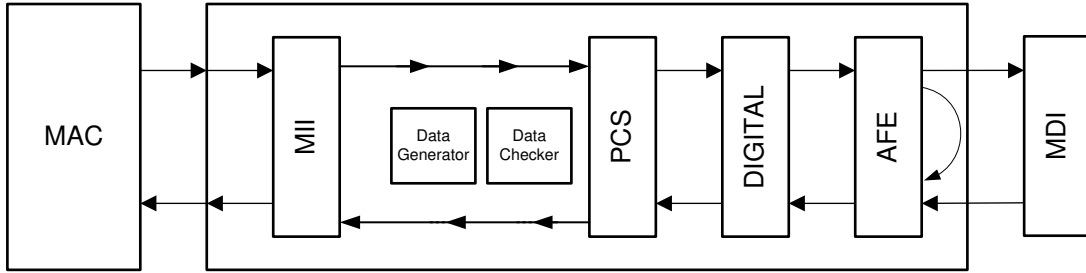

Figure 8-4. Analog Loopback With External Data-Gen

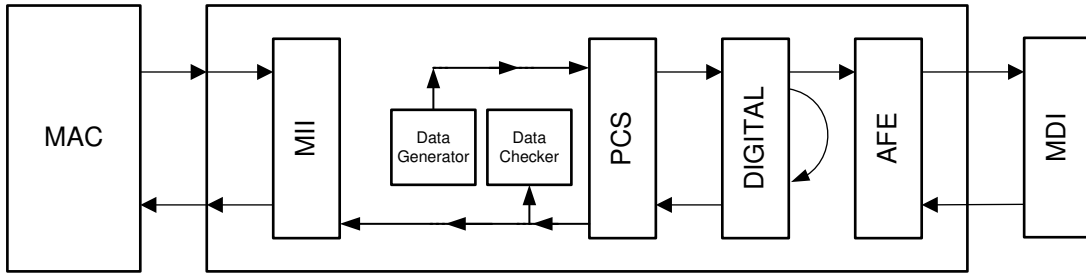

Figure 8-5. Digital Loopback With Inbuilt Data-Gen

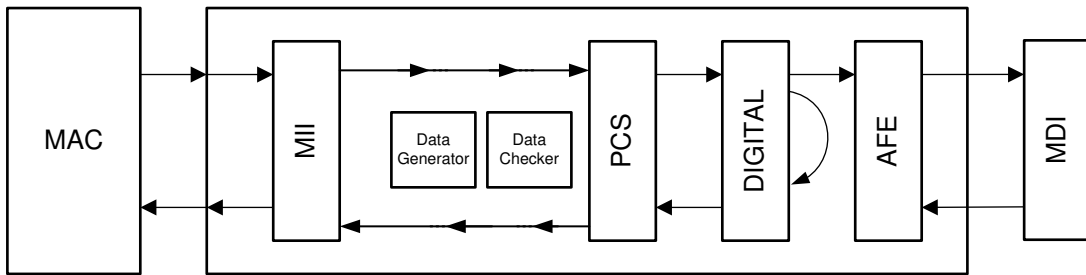

Figure 8-6. Digital Loopback With External Data-Gen

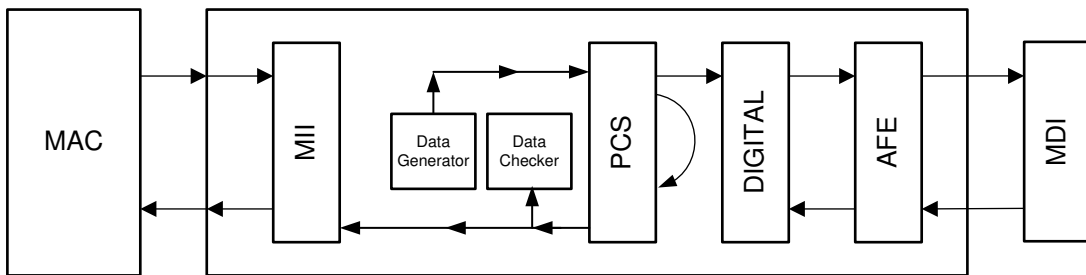

Figure 8-7. PCS Loopback With Inbuilt Data-Gen

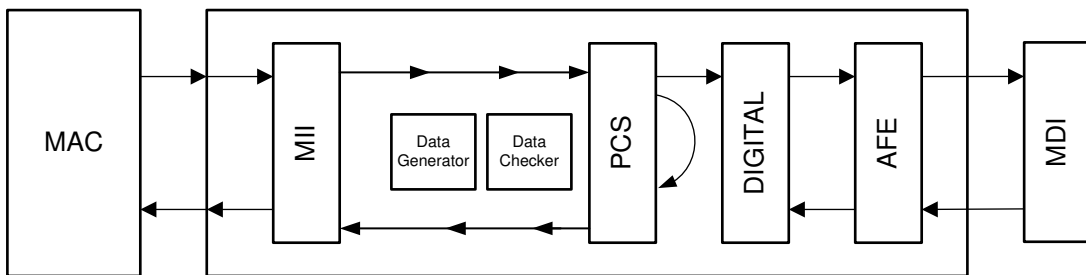

Figure 8-8. PCS Loopback With External Data-Gen

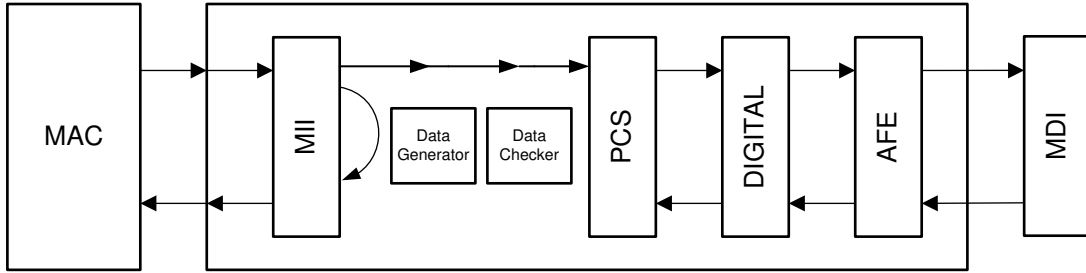

Figure 8-9. xMII Loopback With External Data-Gen

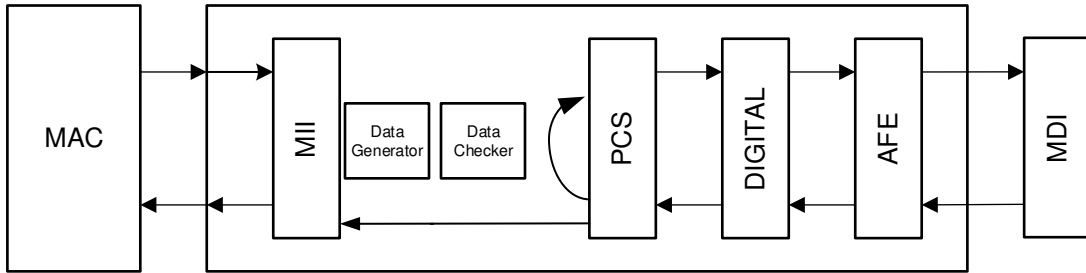

Figure 8-10. xMII Reverse Loopback With External Data-Gen

8.3.1.3.2 Data Generator

Data generator can be programmed to generate either user defined MAC packets or PRBS stream.

Following parameters of generated MAC packets can be configured (refer to registers<0x061B>, register<0x061A> and register<0x0624> for required configuration):

- Packet Length
- Inter-packet gap
- Defined number of packets to be sent or continuous transmission
- Packet data-type: Incremental/Fixed/PRBS
- Number of valid bytes per packet

8.3.1.3.3 Programming Datapath BIST

Following register settings enable different loopbacks, data generation and data checker procedures:

Table 8-2. Datapath BIST Programming

	Loopback Mode	To enable loopback mode	To enable data generator and checker: MAC packets	To check incoming MAC packets status	To enable data generator and checker: PRBS stream	To check incoming PRBS status: PRBS stream	Other care-about
1	Analog loopback	<ul style="list-style-type: none"> • write : reg[0x0016]=0x0008 • write: reg[0x0405]=0x2800 	<ul style="list-style-type: none"> • write : reg[0x0619]=0x1555 • write : reg[0x0624]=0x55BF 	<ul style="list-style-type: none"> • read : reg[0x063C] for (15:0) of total received packets count. • read : reg[0x063D] for (31:16) of total received packets count. • read : reg[0x063E] for Packets received with CRC errors 	<ul style="list-style-type: none"> • write : reg[0x0619]=0x0557 • write : reg[0x0624]=0x55BF 	Step 1 : write : reg[0x0620] (1) = 'b1 Step 2 : <ul style="list-style-type: none"> • read : reg[0x0620](7:0) = Number of error bytes received. • read : reg[0x0620](8) (1 indicates PRBS data is coming in and checker is locked) 	<ul style="list-style-type: none"> • Disconnect the cable/link-partner. • Generated data will be going to MAC side, to disable MAC side : write reg[0x0000]=0x0540

Table 8-2. Datapath BIST Programming (continued)

	Loopback Mode	To enable loopback mode	To enable data generator and checker: MAC packets	To check incoming MAC packets status	To enable data generator and checker: PRBS stream	To check incoming PRBS status: PRBS stream	Other care-about
2	Digital loopback	<ul style="list-style-type: none"> write : reg[0x0016] = 0x0004 write : reg[0x0800][11]=1 	<ul style="list-style-type: none"> write : reg[0x0619]=0x1555 write : reg[0x0624]=0x55BF 	<ul style="list-style-type: none"> read : reg[0x063C] = [15:0] of total received packets count. read : reg[0x063D]= [31:16] of total received packets count. read : reg<0x063E> -> Packets received with CRC errors 	<ul style="list-style-type: none"> write : reg[0x0619]=0x0557 write : reg[0x0624]=0x55BF 	<p>Step 1 : write : reg[0x0620][1] = 1'b1</p> <p>Step 2 :</p> <ul style="list-style-type: none"> read : reg[0x0620][7:0] = Number of error bytes received. read : reg[0x0620][8] (1 indicates PRBS data is coming in and checker is locked) 	<ul style="list-style-type: none"> Generate d data will be going to Cu cable side, to disable this transmission : write reg[0x041F] = 0x1000 Generate d data will be going to MAC side, to disable MAC side : write reg[0x0000]=0x0540

Table 8-2. Datapath BIST Programming (continued)

	Loopback Mode	To enable loopback mode	To enable data generator and checker: MAC packets	To check incoming MAC packets status	To enable data generator and checker: PRBS stream	To check incoming PRBS status: PRBS stream	Other care-about
3	PCS loopback	<ul style="list-style-type: none"> write : reg<0x0016> = 0x0001 	<ul style="list-style-type: none"> write : reg[0x0619]=0x1555 write : reg[0x0624]=0x55BF 	<ul style="list-style-type: none"> read : reg[0x063C]= [15:0] of total received packets count. read : reg[0x063D]= [31:16] of total received packets count. read : reg[0x063E]= Packets received with CRC errors 	<ul style="list-style-type: none"> write : reg[0x0619]=0x0557 write : reg[0x0624]=0x55BF 	Step 1 : write : reg[0x0620][1] = 1'b1 Step 2 : <ul style="list-style-type: none"> read : reg[0x0620][7:0] = Number of error bytes received. read : reg[0x0620][8] (1 indicates PRBS data is coming in and checker is locked) 	<ul style="list-style-type: none"> Generate d data will be going to Cu cable side, to disable this transmission : write reg[0x041F] = 0x1000 Generate d data will be going to MAC side, to disable MAC side : write reg[0x0000]=0x0540

Table 8-2. Datapath BIST Programming (continued)

	Loopback Mode	To enable loopback mode	To enable data generator and checker: MAC packets	To check incoming MAC packets status	To enable data generator and checker: PRBS stream	To check incoming PRBS status: PRBS stream	Other care-about
4	RGMII loopback	<ul style="list-style-type: none"> write : reg<0x0000> = 0x4140 	<ul style="list-style-type: none"> Data is generated externally at Rgmii TX pins Write : reg[0x0619]= 0x1004 	<ul style="list-style-type: none"> Data can be verified at Rgmii RX pins. Packet errors can additionally be checked internally by : <ul style="list-style-type: none"> – read : reg[0x063C]= [15:0] of total received packets count. – read : reg[0x063D] = [31:16] of total received packets count. – read : reg[0x063E]= Packets received with CRC errors 	<ul style="list-style-type: none"> Data is generated externally at Rgmii Tx pins. 	<ul style="list-style-type: none"> Not applicable as data is external. PRBS stream checker works only with internal data generator. 	<ul style="list-style-type: none"> Generated data will be going to Cu cable side, to disable this transmission : write reg[0x041F] = 0x1000

Table 8-2. Datapath BIST Programming (continued)

	Loopback Mode	To enable loopback mode	To enable data generator and checker: MAC packets	To check incoming MAC packets status	To enable data generator and checker: PRBS stream	To check incoming PRBS status: PRBS stream	Other care-about
5	SGMII loopback	<ul style="list-style-type: none"> write : reg[0x0000] = 0x4140 	<ul style="list-style-type: none"> Data is generated externally at Sgmii TX pins Write : reg[0x0619] = 0x1114 	<ul style="list-style-type: none"> Data can be verified at Sgmii RX pins. Packet errors can additionally be checked internally by : <ul style="list-style-type: none"> – read : reg[0x063C] = [15:0] of total received packets count. – read : reg[0x063D] = [31:16] of total received packets count. – read : reg[0x063E] = Packets received with CRC errors 	<ul style="list-style-type: none"> Data is generated externally at Sgmii Tx pins. 	<ul style="list-style-type: none"> Not applicable as data is external. PRBS stream checker works only with internal data generator. 	<ul style="list-style-type: none"> Generated data will be going to Cu cable side, to disable this transmission : write reg[0x041F] = 0x1000

Table 8-2. Datapath BIST Programming (continued)

	Loopback Mode	To enable loopback mode	To enable data generator and checker: MAC packets	To check incoming MAC packets status	To enable data generator and checker: PRBS stream	To check incoming PRBS status: PRBS stream	Other care-about
6	RGMII Reverse loopback	<ul style="list-style-type: none"> write : reg[0x0016] = 0x0010 	<ul style="list-style-type: none"> write : reg[0x0619]=0x1005 write : reg[0x0624]=0x55BF 	<ul style="list-style-type: none"> read : reg[0x063C] = [15:0] of total received packets count. read : reg[0x063D] = [31:16] of total received packets count. read : reg[0x063E] = Packets received with CRC errors 	<ul style="list-style-type: none"> write : reg[0x0619]=0x0557 write : reg[0x0624]=0x55BF 	Step 1 : write : reg[0x0620][1] = 1'b1 Step 2 : <ul style="list-style-type: none"> read : reg[0x0620][7:0] = Number of error bytes received. read : reg[0x0620][8] (1 indicates PRBS data is coming in and checker is locked) 	<ul style="list-style-type: none"> Generate d data will be going to Cu cable side, to disable this transmission : write reg[0x041F] = 0x1000
7	SGMII Reverse loopback	<ul style="list-style-type: none"> write : reg[0x042C] = 0x0010 	<ul style="list-style-type: none"> write : reg[0x0619]=0x1115 write : reg[0x0624]=0x55BF 	<ul style="list-style-type: none"> read : reg[0x063C] for [15:0] of total received packets count. read : reg[0x063D] for [31:16] of total received packets count. read : reg[0x063E] for Packets received with CRC errors 	<ul style="list-style-type: none"> write : reg[0x0619]=0x0557 write : reg[0x0624]=0x55BF 	Step 1 : write : reg[0x0620][1] = 1'b1 Step 2 : <ul style="list-style-type: none"> read : reg[0x0620][7:0] for Number of error bytes received. read : reg[0x0620][8] (1 indicates PRBS data is coming in and checker is locked) 	<ul style="list-style-type: none"> Generate d data will be going to Cu cable side, to disable this transmission : write reg[0x041F] = 0x1000

Note

Different MAC packet parameters can be further configured with register[0x061B] and register[0x0624]

8.3.1.4 Temperature and Voltage Sensing

Temperature sensor of PHY can be used to give the indication of the temperature of the system and reading can be taken on the fly by reading the temperature sensor output register.

Voltage sensor senses the voltage of all the supply pins: vdda, vddio and vdd1p0. Each pins active voltage can be sensed by reading the corresponding voltage sensor output register.

All sensors are always active and monitor state machine polls the value of each sensor periodically. Monitor state machine can be further programmed to give higher priority/sampling time to one sensor over another by using MONITOR_CTRL_3 register.

Following software sequence can be used to read out any sensor's output:

- Step1 : Program register[0x0467] = 0x6004 ; Initial configuration of monitors
- Step 2 : Program register [0x046A] = 0x00A6 and then register [0x046A]=0x00A3; Refresh the monitors
- Step 3 : Program register[0x0468] to select the corresponding sensor to be polled and read register [0x047B] [14:7] for selected sensor's output code.
- Step 4 : Feed the values of read sensor's output code (in decimal) in following equations to get the sensor's output value in decimals. Refer to [Sensor Select Table](#) for required value of constants to be used in equations :
 - $vdda_value = 3.3 + (vdda_output_code - vdda_output_mean_code) * slope_vdda_sensor$
 - $vdd1p0_value = 1.0 + (vdd1p0_output_code - vdd1p0_output_mean_code) * slope_vdd1p0_sensor$
 - $vddio_calculated = 3.3 + (vddio_output_code - vddio_output_mean_code) * slope_vddio_sensor$
 - $temperature_calculated = 25 + (temperature_output_code - temperature_output_mean_code) * slope_temperature_sensor$

Table 8-3. Sensor Select Table

Register[0x0468]	Sensor Selected To Read-out
0x1920	VDDA Voltage Sensor
0x2920	VDD1P0 Voltage Sensor
0x3920	VDDIO Voltage Sensor
0x4920	Temperature Sensor

Table 8-4. Sensor's Constant Values

Constant	Value (in decimal)
vdda_output_mean_code	128
slope_vdda3p3_sensor	8.63014e-3
vdd1p0_output_mean_code	93
slope_vdd1p0_sensor	2.85714e-3
vddio_output_mean_code	224
slope_vddio_sensor	15.686e-3
temperature_output_mean_code	161
slope_temperature_sensor	1.5

Note

Accuracy of temperature sensor can be maximized (7.5degreeC), if customer can sample "temperature_output_code" at 25C and use it as "temperature_output_mean_code".

8.3.1.5 Electrostatic Discharge Sensing

Electrostatic discharge is a serious issue for electronic circuits and if not properly mitigated can create short-term issues (signal integrity, link drops, packet loss) as well as long-term reliability faults. The DP83TG720R-Q1 has robust integrated ESD circuitry and offers an ESD sensing architecture. ESD events can be detected on MDI pins for further analysis and debug.

The ESD sensing tool is useful for both prototyping and end-applications. Additionally, the DP83TG720R-Q1 provides an interrupt status flag; when an ESD event is logged in the register<0x0442>. Hardware and software resets are ignored by the ESDS register to prevent unwarranted clearing.

Table 8-5. ESD Sensing : Interrupt Setting and Count Reading

Function	Required Read/Write
Interrupt Enable	<ul style="list-style-type: none"> • Write register<0x0012>[3] = 1
ESD Event Counter	<ul style="list-style-type: none"> • Read register<0x0442>[14:9] • Value in decimal indicates the ESD strikes since power-up.

8.3.2 Compliance Test Modes

The six test modes for the DP83TG720R-Q1 are compliant to IEEE 802.3bp, Sub-clause 97.5.2. Supported test modes allow testing of the transmitter waveform Power Spectral Density (PSD) mask, distortion, MDI Master jitter, MDI Slave jitter, droop, transmitter frequency, frequency tolerance, BER monitoring, return loss, and mode conversion. Any of the three GPIOs can be used to output TX_TCLK for MDI Slave jitter measurement.

8.3.2.1 Test Mode 1

Test mode 1 tests the transmitter clock jitter when linked to a partner. In test mode 1, the DP83TG720R-Q1 PHYs are connected over link segment defined in section 97.6 within IEEE 802.3bp. TX_TCLK125 is a divided clock derived from TX_TCLK, which is one sixth the frequency.

8.3.2.2 Test Mode 2

Test mode 2 tests the transmitter MDI Master mode jitter. In test mode 2, the DP83TG720R-Q1 will transmit a continuous pattern of three {+1} symbols followed by three {-1} symbols. The transmitted symbols are timed from the 750-MHz source, which results in a 125-MHz signal.

8.3.2.3 Test Mode 4

Test mode 4 tests the transmitter distortion. In test mode 4, the DP83TG720R-Q1 will transmit the sequence of symbols generated by [Equation 1](#):

$$g(x) = 1 + x^9 + x^{11} \quad (1)$$

The bit sequences, x0n and x1n, are generated from combinations of the scrambler in accordance to and :

$$x0_n = \text{Scr}_n[0] \quad (2)$$

$$x1_n = \text{Scr}_n[1] \wedge \text{Scr}_n[4] \quad (3)$$

$$x2_n = \text{Scr}_n[1] \wedge \text{Scr}_n[5] \quad (4)$$

Example streams of the 3-bit nibbles are shown in [Table 8-6](#).

Table 8-6. Transmitter Test Mode 4 Symbol Mapping

x2n	x1n	x0n	T1n	T0n
0	0	0	-1	-1
0	0	1	0	-1
0	1	0	-1	0
0	1	1	-1	+1
1	0	0	+1	0
1	0	1	+1	-1
1	1	0	+1	+1
1	1	1	0	+1

8.3.2.4 Test Mode 5

Test mode 5 tests the transmitter PSD mask. In test mode 5, the DP83TG720R-Q1 will transmit normal Inter-Frame IDLE PAM3 symbols.

8.3.2.5 Test Mode 6

Test mode 6 tests the transmitter droop. In test mode 6, the DP83TG720R-Q1 transmits fifteen {+1} symbols followed by fifteen {-1} symbols with symbol transmission at 750-MHz. This 25-MHz pattern is repeated continuously until the test mode is disabled.

8.3.2.6 Test Mode 7

Test mode 7 enabled bit error rate measurement on a link segment. This mode uses zero data pattern on the MDI to check BER by comparing an expected zero data pattern to any non-zero bit received. Error checking is performed after FEC and 80B/81B decoding.

Table 8-7. Test Mode Register Setting

MMD	Register	Value	Test Mode
MMD1	0x0904	0x2000	Test Mode 1 : Tx_Tclk 125MHz is routed to clkout pin.
MMD1	0x0904	0x4000	Test Mode 2
MMD1	0x0904	0x8000	Test Mode 4 : Tx_Tclk 125MHz is routed to clkout pin.
MMD1F	0x0453	0x0019	
MMD1	0x0904	0xA000	Test Mode 5
MMD1	0x0904	0xC000	Test Mode 6
MMD1	0x0904	0xE000	Test Mode 7

8.4 Device Functional Modes

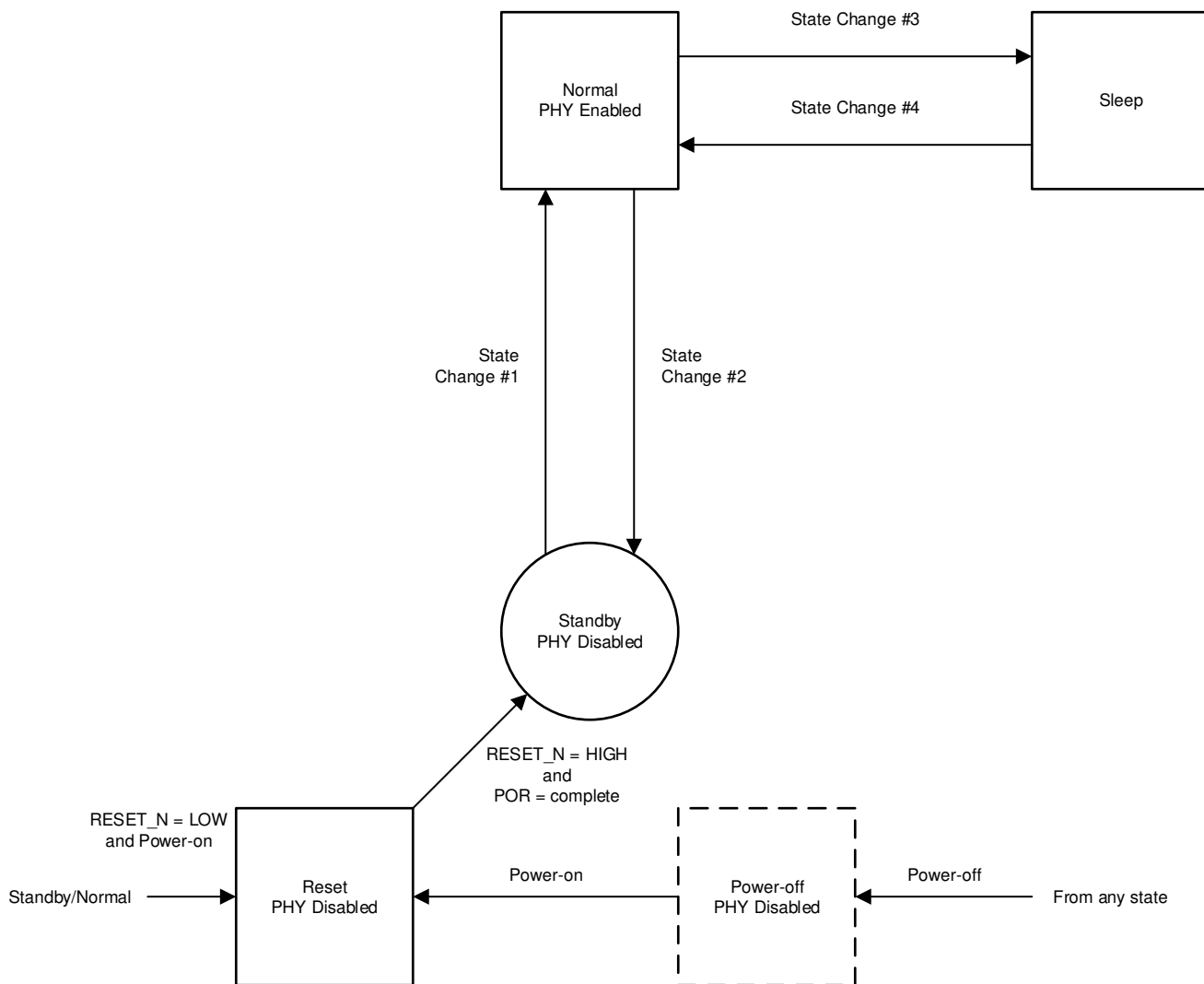

Figure 8-11. PHY Operation State Diagram

8.4.1 Power Down

When VDDA3P3 or VDDIO or VDD1P0 is below the POR threshold, the DP83TG720R-Q1 is in a power-down state. All digital IOs will remain in high impedance state and analog blocks are disabled. PMA termination is not present when in power-down.

8.4.2 Reset

Reset is activated upon power-up, when RESET_N is pulled LOW (for the minimum reset pulse time) or if hardware reset is initiated by setting bit[15] in the register[0x001F].

- Digital state machine restarts after reset and all the register settings are cleared to the boot-up state.
- 25MHz clock on clkout pin will remain active during reset state also.
- MDI/PMA will not have termination during reset state.

Note

Straps are re-latched only with pin reset and not by hardware reset through register (register [0x001F] = x8000).

8.4.3 Standby

The device (MDI Master mode or MDI Slave mode) automatically enters into standby post power-up and reset so long that the device is bootstrapped for managed operation.

In standby, all PHY functions are operational except for PCS and PMA blocks. Link establishment is not possible in standby and data cannot be transmitted or received. SMI functions are operational and register configurations are maintained.

If the device is configured for autonomous operation through bootstrap setting, the PHY automatically switches to normal operation once powered on and reset complete.

8.4.4 Normal

Normal mode can be entered from either autonomous or managed operation. When in autonomous operation, the PHY will automatically try to establish link with a valid Link Partner once powered on.

In managed operation, SMI access is required to allow the device to exit standby; commands issued through the SMI allow the device to exit standby and enables both the PCS and PMA blocks. All device features are operational in normal mode.

Autonomous operation can be enabled through SMI access by setting bit[6] in register 0x18B.

8.4.5 Sleep

Once in sleep mode, all PHY blocks are disabled except for energy detection. All register configurations are lost in sleep mode. No link can be established, data cannot be transmitted or received and SMI access is not available when in sleep mode.

To use sleep mode of PHY refer to implementation highlighted in following figure.

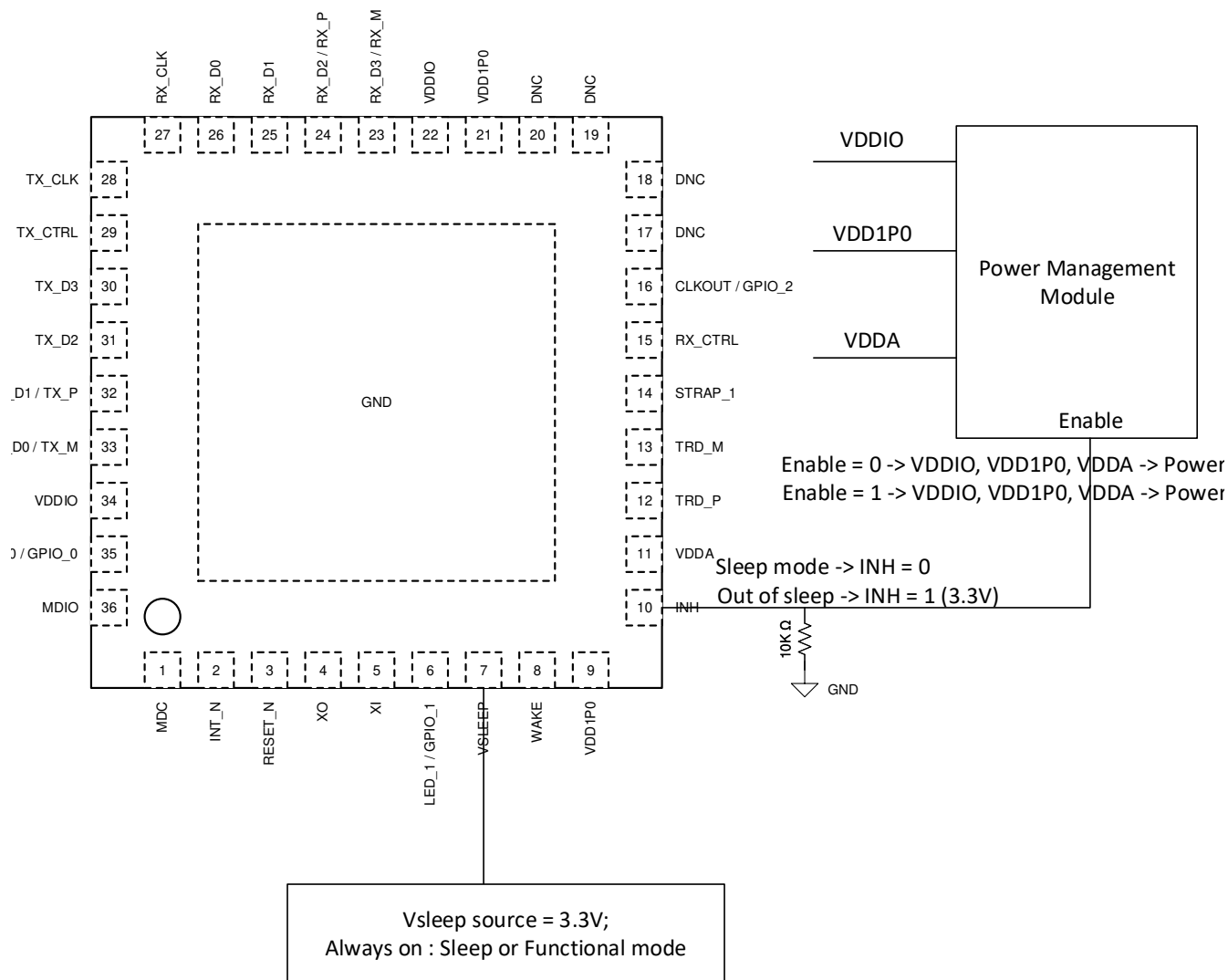

Figure 8-12. Required Implementation for Sleep Mode

Note

Phy will not go into sleep mode if supply sources are not disabled as per above figure.

8.4.6 State Transitions

8.4.6.1 State Transition #1 - Standby to Normal

Autonomous Operation: The PHY will automatically transition to Normal state upon POR completion.

Managed Operation: The PHY will transition to Normal state out of Standby only after writing register <0x018C> = 0x001.

8.4.6.2 State Transition #2 - Normal to Standby

The PHY can be forced back into Standby when in Normal state by writing register <0x018C> = 0x0010.

8.4.6.3 State Transition #3 - Normal to Sleep

Sleep state can be entered either locally (pin/register-write) or by remote link-partner.

Local sleep entry for Master mode phy :

- Step 1 : Write bit[7] = 'b1 of register[0x018B].
- Step 2 : Make "wake" pin low and hold it low for sleep mode.

Local sleep entry for Slave mode phy :

- Step 1 : Write bit[8] = 'b0 of register[0x018B] register.
- Step 2 : Write bit[7] = 'b1 of register[0x018B] register.
- Step 3 : Make "wake" pin low and hold it low for sleep mode.

Remote sleep entry for Master mode phy :

- Master mode phy can not be made to enter sleep mode by link-partner

Remote sleep entry for Slave mode phy :

- Step 1 : Write bit[7] = 'b1 of register[0x018B] register.
- Step 2 : Phy will go into sleep mode with loss of energy on line (when master will go quite : no data, no send-s). This can be achieved by putting link-partner in managed mode (where device is not allowed to start link-up sequence).

Note

Phy will go into sleep mode only if power supplies are disconnected using INH signal as shown in figure **Required Implementation for Sleep Mode**.

8.4.6.4 State Transition #4 - Sleep to Normal

Sleep state can be exited either locally (pin/register-write) or by remote link-partner.

Local Sleep Exit

Local sleep exit for Master mode PHY by :

- Making "wake" pin high (3.3V).

Local sleep exit for Slave mode PHY by :

- Making "wake" pin high (3.3V).

Remote Sleep Exit

Device can be made to exit the sleep mode by link-partner by either of the following :

1. Remote sleep exit using Send-S symbols from link-partner.
2. Remote sleep exit using Send-T symbols from link-partner

Details of these procedures are in the following table :

Table 8-8. Remote Sleep Exit Procedures

Method	Device Mode	Procedure	Required Link-partner Capability
Using Send-S	Master	<p>Step 1 : Start IEEE defined Send-S pattern from link-partner for atleast 1.25ms.</p> <p>Step 2 : Put link-partner in the normal mode to start the link-up.</p> <p>Note : Link-partner with low VOD may limit the remote wake-up upto a maximum of 5m cable.</p>	<p>Link-partner needs to have a mode to send Send-S pattern on demand in Slave mode also.</p> <p>One possible way is :</p> <p>Step 1 : Put link-partner in master mode for atleast 1.25ms.</p> <p>Step 2 : Put link-partner in normal mode to start the link-up</p>
	Slave	<p>Step 1 : Start IEEE defined Send-S pattern from link-partner for atleast 1.25ms.</p> <p>Step 2 : Put link-partner in the normal mode to start the link-up.</p> <p>Note : Link-partner with low VOD may limit the remote wake-up upto a maximum of 5m cable.</p> <p>Note : To keep the slave mode DP83TG720 in sleep mode, link-partner can be put in managed mode (where device is not allowed to start link-up sequence).</p>	<p>Any IEEE compliant link-partner will work, as master mode link-partner is supposed to send Send-S signals to start the link-up</p>

Table 8-8. Remote Sleep Exit Procedures (continued)

Method	Device Mode	Procedure	Required Link-partner Capability
Using Send-T	Master	<p>Step 1 : Enable Send-T pattern on link-partner for atleast 1.25ms.</p> <p>Step 2 : Put link-partner in the normal mode to start the link-up.</p>	<p>Link-partner needs to have a mode to send Send-T pattern on demand.</p> <p>Swing during Send-T mode at pins of link-partner should be greater than 0.92V for remote wake-up over 15m cable. Link-partner with lower VOD may limit the remote wake-up to 5m cable.</p> <p>DP83T720 as link-partner can do the required with following steps :</p> <p>Step 1 : Enable Send-T pattern on DP83TG720 link-partner : write reg[0x0405]=0x7400; reg[0x0509]=0x4007 and reg[0x0576]=0x0500</p> <p>Step 2 : After 100ms disable send-T pattern on DP83TG720 link-partner : write reg[0x0405]=x5800; reg[0x0509]=0x4005 and reg[0x0576]=0x0000</p>
	Slave	<p>Step 1 : Enable Send-T pattern on link-partner for atleast 1.25ms.</p> <p>Step 2 : Put link-partner in the normal mode to start the link-up.</p>	<p>Link-partner needs to have a mode to send Send-T pattern on demand.</p> <p>Swing during Send-T mode at pins of link-partner should be greater than 0.92V for remote wake-up over 15m cable. Link-partner with lower VOD may limit the remote wake-up to 5m cable.</p> <p>DP83T720 as link-partner can do the required with following steps :</p> <p>Step 1 : Enable Send-T pattern on DP83TG720 link-partner : write reg[0x0405]=0x7400; reg[0x0509]=0x4007 and reg[0x0576]=0x0500</p> <p>Step 2 : After 100ms disable send-T pattern on DP83TG720 link-partner : write reg[0x0405]=x5800; reg[0x0509]=0x4005 and reg[0x0576]=0x0000</p>

8.4.7 Media Dependent Interface

8.4.7.1 MDI Master and MDI Slave Configuration

MDI Master and MDI Slave are configured using either hardware bootstraps or through register access.

LED_0 controls the MDI Master and MDI Slave bootstrap configuration. By default, MDI Slave mode is configured because there is an internal pulldown resistor on LED_0 pin. If MDI Master mode configuration through hardware bootstrap is preferred, an external pullup resistor is required.

Additionally, bit[14] in the PMA_CTRL2 register controls the MDI Master and MDI Slave configuration. When this bit is set, MDI Master mode is enabled.

8.4.7.2 Auto-Polarity Detection and Correction

During the link training process, the DP83TG720R-Q1 as MDI receiver is able to detect polarity reversal and automatically correct for the error. Both master and slave detects can do the required correction in the receiver polarity.

Refer to register 0x055B to control the polarity of the PHY's transmitter as required by application. Transmitter polarity can be controlled independent of the received polarity.

8.4.8 MAC Interfaces

8.4.8.1 Reduced Gigabit Media Independent Interface

The DP83TG720R-Q1 also supports Reduced Gigabit Media Independent Interface (RGMI) as specified by RGMI version 2.0. RGMI is designed to reduce the number of pins required to connect MAC and PHY. To accomplish this goal, the control signals are multiplexed. Both rising and falling edges of the clock are used to sample the control signal pin on transmit and receive paths. For 1-Gbps operation, RX_CLK and TX_CLK operate at 125 MHz.

The RGMI signals are summarized in [Table 8-9](#):

Table 8-9. RGMI Signals

FUNCTION	PINS
Data Signals	TX_D[3:0]
	RX_D[3:0]
Control Signals	TX_CTRL
	RX_CTRL
Clock Signals	TX_CLK
	RX_CLK

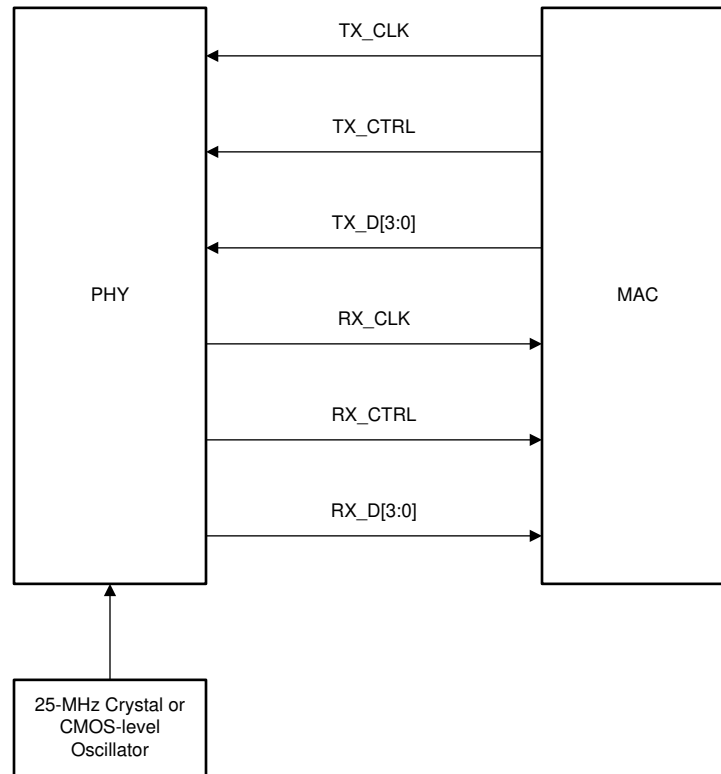

Figure 8-13. RGMI Connections

Table 8-10. RGMII Transmit Encoding

TX_CTRL (POSITIVE EDGE)	TX_CTRL (NEGATIVE EDGE)	TX_D[3:0]	DESCRIPTION
0	0	0000 through 1111	Normal Inter-Frame
0	1	0000 through 1111	Reserved
1	0	0000 through 1111	Normal Data Transmission
1	1	0000 through 1111	Transmit Error Propagation

Table 8-11. RGMII Receive Encoding

RX_CTRL (POSITIVE EDGE)	RX_CTRL (NEGATIVE EDGE)	RX_D[3:0]	DESCRIPTION
0	0	0000 through 1111	Normal Inter-Frame
0	1	0000 through 1101	Reserved
0	1	1110	False Carrier Indication
0	1	1111	Reserved
1	0	0000 through 1111	Normal Data Reception
1	1	0000 through 1111	Data Reception with Errors

The DP83TG720R-Q1 supports in-band status indication to help simplify link status detection. Inter-frame signals on RX_D[3:0] pins as specified in [Table 8-12](#).

Table 8-12. RGMII In-Band Status

RX_CTRL	RX_D3	RX_D[2:1]	RX_D0
0 Note: In-band status is only valid when RX_CTRL is low	Duplex Status: 0 = Half-Duplex 1 = Full-Duplex	RX_CLK Clock Speed: 00 = 2.5 MHz 01 = 25 MHz 10 = 125 MHz 11 = Reserved	Link Status: 0 = Link not established 1 = Valid link established

RGMII MAC Interface for Gigabit Ethernet has stringent timing requirements to meet system level performance. To meet these timing requirements and to operate with different MACs over RGMII, it is advised to take the following requirements into consideration when designing PCB. It is also recommended to check board level signal integrity by using the DP83TG720 IBIS model.

RGMII-TX Requirements

- RGMII TX signals should be routed on board with control impedance of 50Ohm +/-15%.
- Max routing length should be limited to 5inch for better signal integrity performance.
- [Figure 8-14](#) shows a RGMII interface requirements for TX* signals. MAC RGMII driver output impedance should be 50Ohm+/-20%.
- Skew for all RGMII TX signals at TP2, in [Figure 8-14](#), should be $\pm 500\text{ps}$.
- Signal Integrity at TP1 and TP2, in [Figure 8-14](#), should be verified with IBIS model simulation and ensured conformance to following requirements:
 - At TP2, signal should meet rise/fall time of 1ns (20-80%) of signal amplitude.
 - Rise/fall time should be monotonic between VIH/VIL level at TP2.

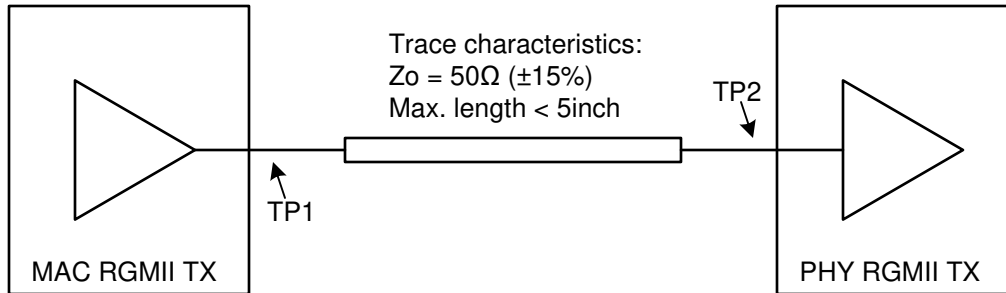

Figure 8-14. RGMII TX Requirements

RGMII-RX Requirements

- RGMII RX signals should be routed on board with control impedance of 50Ohm +/-15%.
- Max routing length should be limited to 5inch for better signal integrity performance.
- No damping resistors should be added at TP3/TP4, in [Figure 8-15](#), as that will impact signal integrity of RX signals.
- [Figure 8-15](#) shows a RGMII interface requirements for RX* signals. MAC RGMII driver output impedance should be 50Ohm+/-20%.
- Signal Integrity at TP3 and TP4, in [Figure 8-15](#), should be verified with IBIS model simulation and ensured conformance to following requirements:
 - At TP4, signal should meet rise/fall time of 1ns (20-80%) of signal amplitude.
 - Rise/fall time should be monotonic between VIH/VIL level at TP4.

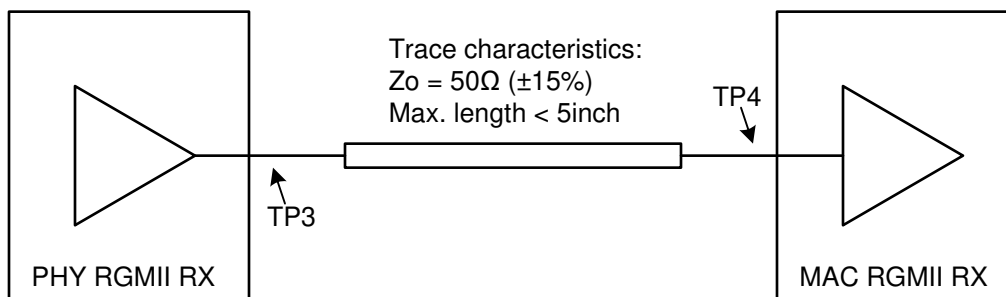

Figure 8-15. RGMII RX Requirements

Note

1. We recommend routing RGMII on buried traces to minimize EMC emissions.
2. Buried traces should be connected with via placement as close as possible to the PHY and MAC.

8.4.9 Serial Management Interface

The Serial Management Interface provides access to the DP83TG720R-Q1 internal register space for status information and configuration. The SMI is compatible with IEEE 802.3 clause 22. The implemented register set consists of the registers required by the IEEE 802.3 plus several others to provide additional visibility and controllability of the DP83TG720R-Q1.

The SMI includes the management clock (MDC) and the management input and output data pin (MDIO). MDC is sourced by the external management entity, also called Station (STA). MDC is not expected to be continuous, and can be turned off by the external management entity when the bus is idle.

MDIO is sourced by the external management entity and by the PHY. The data on the MDIO pin is latched on the rising edge of the MDC. MDIO pin requires a pullup resistor (2.2 K Ω), which pulls MDIO high during IDLE and turnaround.

Up to 9 DP83TG720R-Q1 PHYs can share a common SMI bus. To distinguish between the PHYs, a 3-bit address is used. During power-up-reset, the DP83TG720R-Q1 latches the PHY_AD configuration pins to determine its address.

The management entity must not start an SMI transaction in the first cycle after power-up-reset. To maintain valid operation, the SMI bus must remain inactive at least one MDC cycle after hard reset is deasserted. In normal MDIO transactions, the register address is taken directly from the management-frame reg_addr field, thus allowing direct access to 32 16-bit registers (including those defined in IEEE 802.3 and vendor specific). The data field is used for both reading and writing. The Start code is indicated by a <01> pattern. This pattern makes sure that the MDIO line transitions from the default idle line state. Turnaround is defined as an idle bit time inserted between the Register Address field and the Data field. To avoid contention during a read transaction, no device may actively drive the MDIO signal during the first bit of turnaround. The addressed DP83TG720R-Q1 drives the MDIO with a zero for the second bit of turnaround and follows this with the required data.

For write transactions, the station-management entity writes data to the addressed DP83TG720R-Q1, thus eliminating the requirement for MDIO Turnaround. The turnaround time is filled by the management entity by inserting <10>.

Table 8-13. SMI Protocol Structure

SMI PROTOCOL	<idle> <start> <op code> <device address> <reg address> <turnaround> <data> <idle>
Read Operation	<idle><01><10><AAAA><RRRRR><Z0><XXXX XXXX XXXX XXXX><idle>
Write Operation	<idle><01><01><AAAA><RRRRR><10><XXXX XXXX XXXX XXXX><idle>

8.4.10 Direct Register Access

Direct register access can be used for the first 31 registers (0x0h through 0x1Fh).

8.4.11 Extended Register Space Access

The DP83TG720R-Q1 SMI function supports read and write access to the extended register set using registers REGCR (0x000Dh) and ADDAR (0x000Eh) and the MDIO Manageable Device (MMD) indirect method defined in IEEE 802.3ah Draft for Clause 22 for accessing the Clause 45 extended register set.

REGCR (0x000Dh) is the MDIO Manageable MMD access control. In general, register REGCR[4:0] is the device address DEVAD that directs any accesses of ADDAR (0x000Eh) register to the appropriate MMD.

The DP83TG720R-Q1 supports 4 MMD device addresses. The 4 MMD register spaces are:

1. DEVAD[4:0] = 1111 (0x1F) is used for IEEE defined registers (0x00 to 0x1F) and vendor specific registers. This register space is called MMD1F
2. DEVAD[4:0] = 00001 (0x01) is used for 1000BASE-T1 PMA MMD register accesses. This register space is called MMD1.
3. DEVAD[4:0] = 00011 (0x03) is used for vendor specific registers. This register space is called MMD3
4. DEVAD[4:0] = 00111 (0x07) is used for vendor specific registers. This register space is called MMD7

Table 8-14. MMD Register Space Division

MMD Register Space	Register Address Range
MMD1F	0x000 - 0x0EFD
MMD1	0x1000 - 0x1904
MMD3	0x3000 - 0x390D
MMD7	0x7000 - 0x7200

Note

For MMD1/3/7, most significant nibble of the register address is used to denote the respective MMD space. This should be ignored during actual register access operation. For example to access register 0x1904 use 0x0904 as the register address and x01 as the MMD.

All accesses through register REGCR and ADDAR must use the correct DEVAD. Transactions with other DEVADs are ignored. REGCR[15:14] holds the access function: address (00), data with no post increment (01), data with post increment on read and writes (10) and data with post increment on writes only (11).

- ADDAR is the address and data MMD register. ADDAR is used in conjunction with REGCR to provide the access to the extended register set. If register REGCR[15:14] is (00), then ADDAR holds the address of the extended address space register. Otherwise, ADDAR holds the data as indicated by the contents of its address register. When REGCR[15:14] is set to (00), accesses to register ADDAR modify the extended register set address register. This address register must always be initialized in order to access any of the registers within the extended register set.
- When REGCR[15:14] is set to (01), accesses to register ADDAR access the register within the extended register set selected by the value in the address register.
- When REGCR[15:14] is set to (10), access to register ADDAR access the register within the extended register set selected by the value in the address register. After that access is complete, for both reads and writes, the value in the address register is incremented.
- When REGCR[15:14] is set to (11), access to register ADDAR access the register within the extended register set selected by the value in the address register. After that access is complete, for write access only, the value in the address register is incremented. For read accesses, the value of the address register remains unchanged.

The following sections describe how to perform operations on the extended register set using register REGCR and ADDAR.

8.4.12 Write Address Operation

To set the address register:

1. Write the value 0x001F (address function field = 00, DEVAD = '11111') to register REGCR.
2. Write the register address to register ADDAR.

Subsequent writes to register ADDAR (step 2) continue to write the address register.

8.4.12.1 Example - Write Address Operation

For writing register addresses within MMD1 field:

1. Write the value 0x0001 (address function field = 00, DEVAD = '00001') to register REGCR.
2. Write the register address to register ADDAR.

8.4.13 Read Address Operation

To read the address register:

1. Write the value 0x001F (address function field = 00, DEVAD = '11111') to register REGCR.
2. Read the register address from register ADDAR.

Subsequent reads to register ADDAR (step 2) continue to read the address register.

8.4.13.1 Example - Read Address Operation

For reading register addresses within MMD1 field:

1. Write the value 0x0001 (address function field = 00, DEVAD = '00001') to register REGCR.
2. Read the register address from register ADDAR.

8.4.14 Write Operation (No Post Increment)

To write a register in the extended register set:

1. Write the value 0x001F (address function field = 00, DEVAD = '11111') to register REGCR.
2. Write the desired register address to register ADDAR.
3. Write the value 0x401F (data, no post increment function field = 01, DEVAD = '11111') to register REGCR.
4. Write the content of the desired extended register set to register ADDAR.

Subsequent writes to register ADDAR (step 4) continue to rewrite the register selected by the value in the address register.

Note

Steps (1) and (2) can be skipped if the address register was previously configured.

8.4.14.1 Example - Write Operation (No Post Increment)

To write a register in the MMD1 extended register set:

1. Write the value 0x0001 (address function field = 00, DEVAD = '00001') to register REGCR.
2. Write the desired register address to register ADDAR.
3. Write the value 0x4001 (data, no post increment function field = 01, DEVAD = '00001') to register REGCR.
4. Write the content of the desired extended register set to register ADDAR.

8.4.15 Read Operation (No Post Increment)

To read a register in the extended register set:

1. Write the value 0x001F (address function field = 00, DEVAD = '11111') to register REGCR.
2. Write the desired register address to register ADDAR.
3. Write the value 0x401F (data, no post increment function field = 01, DEVAD = '11111') to register REGCR.
4. Read the content of the desired extended register set in register ADDAR.

Subsequent reads to register ADDAR (step 4) continue to reading the register selected by the value in the address register.

Note

Steps (1) and (2) can be skipped if the address register was previously configured.

8.4.15.1 Example - Read Operation (No Post Increment)

To read a register in the MMD1 extended register set:

1. Write the value 0x0001 (address function field = 00, DEVAD = '00001') to register REGCR.
2. Write the desired register address to register ADDAR.
3. Write the value 0x4001 (data, no post increment function field = 01, DEVAD = '00001') to register REGCR.
4. Read the content of the desired extended register set in register ADDAR.

8.4.16 Write Operation (Post Increment)

To write a register in the extended register set with post increment:

1. Write the value 0x001F (address function field = 00, DEVAD = '11111') to register REGCR.
2. Write the desired register address to register ADDAR.

3. Write the value 0x801F (data, post increment function field = 10, DEVAD = '11111') or the value 0xC01F (data, post increment on writes function field = 11, DEVAD = '11111') to register REGCR.
4. Write the content of the desired extended register set to register ADDAR.

Subsequent writes to register ADDAR (step 4) write the next higher addressed data register selected by the value of the address register; the address register is incremented after each access.

8.4.16.1 Example - Write Operation (Post Increment)

To write a register in the MMD1 extended register set with post increment:

1. Write the value 0x0001 (address function field = 00, DEVAD = '00001') to register REGCR.
2. Write the desired register address to register ADDAR.
3. Write the value 0x8001 (data, post increment function field = 10, DEVAD = '00001') or the value 0xC001 (data, post increment on writes function field = 11, DEVAD = '00001') to register REGCR.
4. Write the content of the desired extended register set to register ADDAR.

8.4.17 Read Operation (Post Increment)

To read a register in the extended register set and automatically increment the address register to the next higher value following the write operation:

1. Write the value 0x001F (address function field = 00, DEVAD = '11111') to register REGCR.
2. Write the desired register address to register ADDAR.
3. Write the value 0x801F (data, post increment function field = 10, DEVAD = '11111') to register REGCR.
4. Read the content of the desired extended register set in register ADDAR.

Subsequent reads to register ADDAR (step 4) read the next higher addressed data register selected by the value of the address register; the address register is incremented after each access.

8.4.17.1 Example - Read Operation (Post Increment)

To read a register in the MMD1 extended register set and automatically increment the address register to the next higher value following the write operation:

1. Write the value 0x0001 (address function field = 00, DEVAD = '00001') to register REGCR.
2. Write the desired register address to register ADDAR.
3. Write the value 0x8001 (data, post increment function field = 10, DEVAD = '00001') to register REGCR.
4. Read the content of the desired extended register set in register ADDAR.

8.5 Programming

8.5.1 Strap Configuration

The DP83TG720R-Q1 uses functional pins as strap options to place the device into specific modes of operation. The values of these pins are sampled at power up and hardware reset (through either the RESET_N pin or register access). The strap pins support 2-levels and 3-levels, which are described in greater detail below. Configuration of the device may be done through strapping or through serial management interface.

Note

- Because strap pins are functional pins after reset is deasserted, they should not be connected directly to VCC or GND.
- Pull up strap resistors are sufficient to enter different strap modes.
- Pull down strap resistor can have application for LED pin straps. Refer to LED Configuration section.

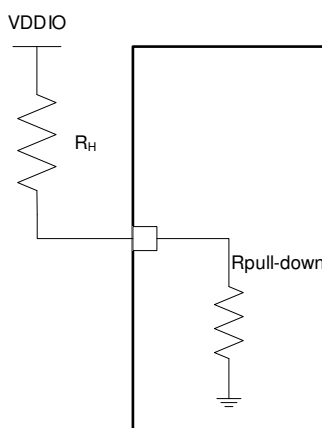

Figure 8-16. Strap Circuit

Table 8-15. Recommended 3-level Strap Resistor Ratios

MODE	IDEAL RH (kΩ) ¹ for VDDIO = 3.3 V	IDEAL RH (kΩ) ² for VDDIO = 2.5 V	IDEAL RH (kΩ) ¹ for VDDIO = 1.8V
1	OPEN	OPEN	OPEN
2	13	12	4
3	4.5	2	0.8

1. 10% resistor accuracy
2. 1% resistor accuracy

Table 8-16. Recommended 2-level Strap Resistor

MODE	IDEAL RH (kΩ) ¹²
1	OPEN
2	2.49

1. 10% resistor accuracy
2. To gain more margin in customer application for 1.8V VDDIO, either 2.1K+/-10% pull-up can be used or resistor accuracy of 2.49K resistor can be limited to 1%.

The following table describes the DP83TG720R-Q1 configuration bootstraps:

Table 8-17. 2-level Bootstraps

PIN NAME	PIN NO.	STRAP MODE	STRAP FUNCTION	DESCRIPTION
RX_D0	26	1 (default)	MAC[0] = 0	MAC Interface Selection [0]. Refer to Table 8-18 for full description.
		2	MAC[0] = 1	
RX_D1	25	1 (default)	MAC[1] = 0	MAC Interface Selection [1]. Refer to Table 8-18 for full description.
		2	MAC[1] = 1	
RX_D2	24	1 (default)	MAC[2] = 0	MAC Interface Selection [2]. Refer to Table 8-18 for full description.
		2	MAC[2] = 1	
LED_0	1	1 (default)	MS = 0	MDI Master Slave Select. MS = 0 Slave MS = 1 Master
		2	MS = 1	
LED_1	6	1 (default)	$\overline{\text{AUTO}} = 0$	Autonomous Disable $\overline{\text{AUTO}} = 0$ Autonomous AUTO = 1 Managed
		2	$\overline{\text{AUTO}} = 1$	

Table 8-18. MAC Interface Selection Bootstraps

MAC[2]	MAC[1]	MAC[0]	DESCRIPTION
0	0	0	RESERVED
0	0	1	RESERVED
0	1	0	RESERVED
0	1	1	RESERVED
1	0	0	RGMI (Align Mode)
1	0	1	RGMI (TX Shift Mode)
1	1	0	RGMI (TX and RX Shift Mode)
1	1	1	RGMI (RX Shift Mode)

Table 8-19. 3-Level Bootstrap: PHY Address

PHY_AD[3:0]	RX_CTRL STRAP MODE	STRP_1 STRAP MODE	DESCRIPTION
0000	1	1	PHY Address: 0x0000 (0)
0001	-	-	RESERVED
0010	-	-	RESERVED
0011	-	-	RESERVED
0100	2	1	PHY Address: 0x0004 (4)
0101	3	1	PHY Address: 0x0005 (5)
0110	-	-	RESERVED
0111	-	-	RESERVED
1000	1	2	PHY Address: 0x0008 (8)
1001	-	-	RESERVED
1010	1	3	PHY Address: 0x000A (10)
1011	-	-	RESERVED
1100	2	2	PHY Address: 0x000C (12)
1101	3	2	PHY Address: 0x000D (13)
1110	2	3	PHY Address: 0x000E (14)
1111	3	3	PHY Address: 0x000F (15)

8.5.2 LED Configuration

The DP83TG720R-Q1 supports up to three configurable Light Emitting Diode (LED) pins: LED_0, LED_1, and LED_2 (CLKOUT). Several functions can be multiplexed onto the LEDs for different modes of operation. LED operations are selected using registers 0x0450 and 0x0451.

Note

CLKOUT has 25MHz clock output as default. If required, it can be configured to LED2 using register 0x0453.

Because the LED output pins are also used as strap pins, external components required for strapping and the user must consider the LED usage to avoid contention. Specifically, when the LED outputs are used to drive LEDs directly, the active state of each output driver is dependent on the logic level sampled by the corresponding input upon power up or hardware reset.

Figure 8-17 shows the two proper ways of connecting LEDs directly to the DP83TG720R-Q1.

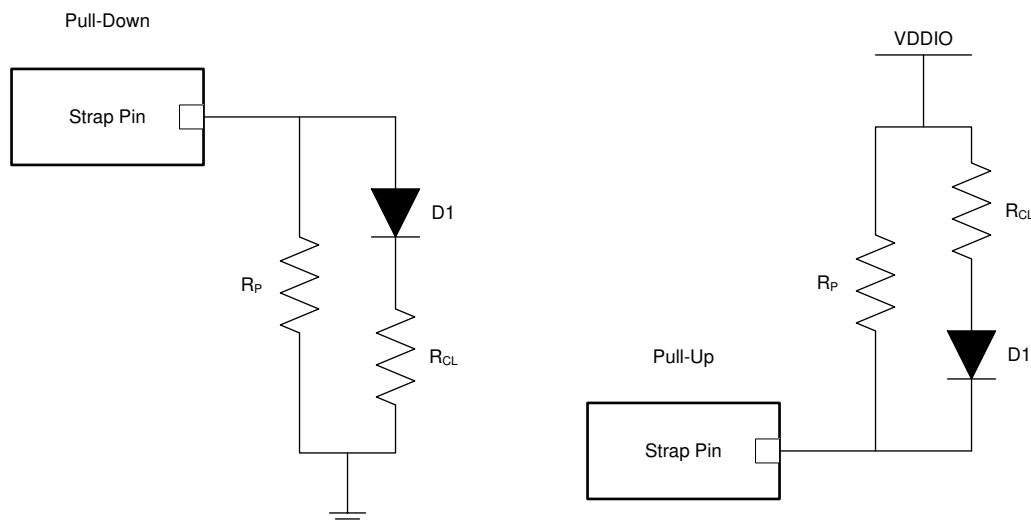

Figure 8-17. Example Strap Connections

8.5.3 PHY Address Configuration

The DP83TG720R-Q1 can be set to respond to any of 9 possible PHY addresses through bootstrap pins. The PHY address is latched into the device upon power-up or hardware reset. Each DP83TG720R-Q1 or port sharing PHY on the serial management bus in the system must have a unique PHY address. The DP83TG720R-Q1 supports PHY address as described in [Table 8-19](#).

By default, the DP83TG720R-Q1 will latch to a PHY address of 0 ([0000]). This address can be changed by adding pullup resistors to bootstrap pins found in [Table 8-17](#).

8.6 Register Maps

8.6.1 Register Access Summary

There are two different methods for accessing registers within the field. Direct register access method is only allowed for the first 31 registers (0x0h through 0x1Fh) of MMD1F register space. Registers beyond 0x1Fh must be accessed by use of the Indirect Method (Extended Register Space) described in [Section 8.4.11](#).

Table 8-20. MMD Register Space Division

MMD REGISTER SPACE	REGISTER ADDRESS RANGE
MMD1F	0x000 - 0x0EFD
MMD1	0x1000 - 0x1904
MMD3	0x3000 - 0x390D
MMD7	0x7000 - 0x7200

Table 8-21. Register Access Summary

REGISTER FIELD	REGISTER ACCESS METHODS
0x0h through 0x1Fh	Direct Access
	Indirect Access, MMD1F = '11111' Example: to read register 0x17h in MMD1F field with no post increment Step 1) write 0x1Fh to register 0xDh Step 2) write 0x17h to register 0xEh Step 3) write 0x401Fh to register 0xDh Step 4) read register 0xEh
MMD1F Field 0x20h - 0xFFFFh	Indirect Access, MMD1F = '11111' Example: to read register 0x462h in MMD1F field with no post increment Step 1) write 0x1Fh to register 0xDh Step 2) write 0x462h to register 0xEh Step 3) write 0x401Fh to register 0xDh Step 4) read register 0xEh
MMD1 Field 0x0000h - 0xFFFFh	Indirect Access, MMD1 = '00001' Example: to read register 0x7h in MMD1 field with no post increment Step 1) write 0x1h to register 0xDh Step 2) write 0x7h to register 0xEh Step 3) write 0x4001h to register 0xDh Step 4) read register 0xEh

8.6.2 Register Map

Table 8-22. DP83TG720 Access Type Codes

Access Type	Code	Description
Read Type		
R	R	Read
Write Type		
W	W	Write
W0C	W 0C	Write 0 to clear
W0S	W 0S	Write 0 to set
WMC	W	Write with manual clear to default (refer to register description to know about the clearing event)
WMC,0	W	Write with manual clear to 0 (refer to register description to know about the clearing event)
WMC,1	W	Write with manual clear to 1 (refer to register description to know about the clearing event)
WSC	W	Write with self clear to default (written value be cleared automatically)
WSC,0	W	Write with self clear to 0

Table 8-22. DP83TG720 Access Type Codes (continued)

Access Type	Code	Description
Reset or Default Value		
-n		Value after reset or the default value

8.6.2.1 DP83TG720 Registers

Table 8-23 lists the DP83TG720 registers. All register offset addresses not listed in Table 8-23 should be considered as reserved locations and the register contents should not be modified.

Table 8-23. DP83TG720 Registers

Offset	Acronym	Register Name	Section
0h	BMCR		Go
1h	BMSR		Go
2h	PHYID1		Go
3h	PHYID2		Go
Dh	REGCR		Go
Eh	ADDAR		Go
10h	MII_REG_10		Go
11h	MII_REG_11		Go
12h	MII_REG_12		Go
13h	MII_REG_13		Go
16h	MII_REG_16		Go
18h	MII_REG_18		Go
19h	MII_REG_19		Go
1Eh	MII_REG_1E		Go
1Fh	MII_REG_1F		Go
180h	C_AND_S_STATUS		Go
181h	PM_TOP_CFG		Go
182h	CLK_CTRL_CFG		Go
183h	LPS_CFG		Go
18Bh	LPS_CFG2		Go
18Ch	LPS_CFG3		Go
18Eh	LPS_STATUS		Go
309h	TDR_STATUS0		Go
30Ah	TDR_STATUS1		Go
30Bh	TDR_STATUS2		Go
30Eh	TDR_STATUS5		Go
30Fh	TDR_TC12		Go
405h	A2D_REG_05		Go
41Fh	A2D_REG_31		Go
428h	A2D_REG_40		Go
429h	A2D_REG_41		Go
42Ah	A2D_REG_42		Go
42Bh	A2D_REG_43		Go
42Ch	A2D_REG_44		Go
42Dh	A2D_REG_45		Go
42Eh	A2D_REG_46		Go
430h	A2D_REG_48		Go

Table 8-23. DP83TG720 Registers (continued)

Offset	Acronym	Register Name	Section
442h	A2D_REG_66		Go
450h	LEDS_CFG_1		Go
451h	LEDS_CFG_2		Go
452h	IO_MUX_CFG_1		Go
453h	IO_MUX_CFG_2		Go
454h	IO_CONTROL_1		Go
455h	IO_CONTROL_2		Go
456h	IO_CONTROL_3		Go
457h	IO_STATUS_1		Go
458h	IO_STATUS_2		Go
459h	IO_CONTROL_4		Go
45Ah	IO_CONTROL_5		Go
45Dh	SOR_VECTOR_1		Go
45Eh	SOR_VECTOR_2		Go
466h	REV_ID		Go
467h	MONITOR_CTRL1		Go
468h	MONITOR_CTRL2		Go
46Ah	MONITOR_CTRL4		Go
47Bh	MONITOR_STAT1		Go
509h	SYNC_LINK_CONTROL_CFG		Go
50Ah	BREAK_LINK_TIMER		Go
514h	LPS_CONTROL_1		Go
515h	LPS_CONTROL_2		Go
518h	MAXWAIT_TIMER		Go
519h	PHY_CTRL_1G		Go
531h	TEST_MODE		Go
543h	LINK_QUAL_1		Go
544h	LINK_QUAL_2		Go
545h	LINK_DOWN_LATCH_STAT		Go
547h	LINK_QUAL_3		Go
548h	LINK_QUAL_4		Go
559h	PMA_WATCHDOG		Go
55Ah	DATA_SCR_CFG		Go
55Bh	SYMB_POL_CFG		Go
55Ch	OAM_CFG		Go
561h	TEST_MEM_CFG		Go
573h	FORCE_CTRL1		Go
580h	MBIST_CTRL		Go
581h	MBIST_STAT		Go
600h	RGMII_CTRL		Go
601h	RGMII_FIFO_STATUS		Go
602h	RGMII_DELAY_CTRL		Go
608h	SGMII_CTRL_1		Go
609h	SGMII_EEE_CTRL_1		Go
60Ah	SGMII_STATUS		Go

Table 8-23. DP83TG720 Registers (continued)

Offset	Acronym	Register Name	Section
60Bh	SGMII_EEE_CTRL_2		Go
60Ch	SGMII_CTRL_2		Go
60Dh	SGMII_FIFO_STATUS		Go
618h	PRBS_STATUS_1		Go
619h	PRBS_CTRL_1		Go
61Ah	PRBS_CTRL_2		Go
61Bh	PRBS_CTRL_3		Go
61Ch	PRBS_STATUS_2		Go
61Dh	PRBS_STATUS_3		Go
61Eh	PRBS_STATUS_4		Go
620h	PRBS_STATUS_6		Go
622h	PRBS_STATUS_8		Go
623h	PRBS_STATUS_9		Go
624h	PRBS_CTRL_4		Go
625h	PRBS_CTRL_5		Go
626h	PRBS_CTRL_6		Go
627h	PRBS_CTRL_7		Go
628h	PRBS_CTRL_8		Go
629h	PRBS_CTRL_9		Go
62Ah	PRBS_CTRL_10		Go
638h	CRC_STATUS		Go
639h	PKT_STAT_1		Go
63Ah	PKT_STAT_2		Go
63Bh	PKT_STAT_3		Go
63Ch	PKT_STAT_4		Go
63Dh	PKT_STAT_5		Go
63Eh	PKT_STAT_6		Go
800h	DSP_REG_0		Go
871h	SQI_REG_1		Go
8ADh	SQI_1		Go
8EDh	SQI_2		Go
8EFh	SQI_3		Go
8F0h	SQI_4		Go
8F1h	SQI_5		Go
8F2h	SQI_6		Go
1000h	PMA_PMD_CONTROL_1	First nibble (0x1) in the register address is to indicated MMD register space. For register access, ignore the first nibble.	Go
1007h	PMA_PMD_CONTROL_2	First nibble (0x1) in the register address is to indicated MMD register space. For register access, ignore the first nibble.	Go
1009h	PMA_PMD_TRANSMIT_DISABLE	First nibble (0x1) in the register address is to indicated MMD register space. For register access, ignore the first nibble.	Go
100Bh	PMA_PMD_EXTENDED_ABILITY2	First nibble (0x1) in the register address is to indicated MMD register space. For register access, ignore the first nibble.	Go

Table 8-23. DP83TG720 Registers (continued)

Offset	Acronym	Register Name	Section
1012h	PMA_PMD_EXTENDED_ABILITY	First nibble (0x1) in the register address is to indicated MMD register space. For register access, ignore the first nibble.	Go
1834h	PMA_PMD_CONTROL	First nibble (0x1) in the register address is to indicated MMD register space. For register access, ignore the first nibble.	Go
1900h	PMA_CONTROL	First nibble (0x1) in the register address is to indicated MMD register space. For register access, ignore the first nibble.	Go
1901h	PMA_STATUS	First nibble (0x1) in the register address is to indicated MMD register space. For register access, ignore the first nibble.	Go
1902h	TRAINING	First nibble (0x1) in the register address is to indicated MMD register space. For register access, ignore the first nibble.	Go
1903h	LP_TRAINING	First nibble (0x1) in the register address is to indicated MMD register space. For register access, ignore the first nibble.	Go
1904h	TEST_MODE_CONTROL	First nibble (0x1) in the register address is to indicated MMD register space. For register access, ignore the first nibble.	Go
3000h	PCS_CONTROL_COPY	First nibble (0x3) in the register address is to indicated MMD register space. For register access, ignore the first nibble.	Go
3900h	PCS_CONTROL	First nibble (0x3) in the register address is to indicated MMD register space. For register access, ignore the first nibble.	Go
3901h	PCS_STATUS	First nibble (0x3) in the register address is to indicated MMD register space. For register access, ignore the first nibble.	Go
3902h	PCS_STATUS_2	First nibble (0x3) in the register address is to indicated MMD register space. For register access, ignore the first nibble.	Go
3904h	OAM_TRANSMIT	First nibble (0x3) in the register address is to indicated MMD register space. For register access, ignore the first nibble.	Go
3905h	OAM_TX_MESSAGE_1	First nibble (0x3) in the register address is to indicated MMD register space. For register access, ignore the first nibble.	Go
3906h	OAM_TX_MESSAGE_2	First nibble (0x3) in the register address is to indicated MMD register space. For register access, ignore the first nibble.	Go
3907h	OAM_TX_MESSAGE_3	First nibble (0x3) in the register address is to indicated MMD register space. For register access, ignore the first nibble.	Go
3908h	OAM_TX_MESSAGE_4	First nibble (0x3) in the register address is to indicated MMD register space. For register access, ignore the first nibble.	Go
3909h	OAM_RECEIVE	First nibble (0x3) in the register address is to indicated MMD register space. For register access, ignore the first nibble.	Go
390Ah	OAM_RX_MESSAGE_1	First nibble (0x3) in the register address is to indicated MMD register space. For register access, ignore the first nibble.	Go
390Bh	OAM_RX_MESSAGE_2	First nibble (0x3) in the register address is to indicated MMD register space. For register access, ignore the first nibble.	Go

Table 8-23. DP83TG720 Registers (continued)

Offset	Acronym	Register Name	Section
390Ch	OAM_RX_MESSAGE_3	First nibble (0x3) in the register address is to indicated MMD register space. For register access, ignore the first nibble.	Go
390Dh	OAM_RX_MESSAGE_4	First nibble (0x3) in the register address is to indicated MMD register space. For register access, ignore the first nibble.	Go
7200h	AN_CFG	First nibble (0x7) in the register address is to indicated MMD register space. For register access, ignore the first nibble.	Go

8.6.2.1.1 BMCR Register (Offset = 0h) [Reset = 40h]

BMCR is shown in [Table 8-24](#).

Return to the [Summary Table](#).

Table 8-24. BMCR Register Field Descriptions

Bit	Field	Type	Reset	Description
15	mii_reset	R/W/MC	0h	1b = Digital in reset and all MII regs (0x0 - 0xF) reset to default 0b = No reset
14	loopback	R/W	0h	1b = MII loopback 0b = No MII loopback
13	RESERVED	R	0h	Reserved
12	RESERVED	R	0h	Reserved
11	power_down	R/W	0h	1b = Power down via register or pin 0b = Normal mode
10	isolate	R/W	0h	1b = Isolate mode 0b = Normal mode
9	RESERVED	R	0h	Reserved
8	RESERVED	R	0h	Reserved
7	RESERVED	R	0h	Reserved
6	speed_sel_msb	R	1h	0b= Reserved 1b= 1000 Mb/s
5	RESERVED	R	0h	Reserved
4-0	RESERVED	R	0h	Reserved

8.6.2.1.2 BMSR Register (Offset = 1h) [Reset = 141h]

BMSR is shown in [Table 8-25](#).

Return to the [Summary Table](#).

Table 8-25. BMSR Register Field Descriptions

Bit	Field	Type	Reset	Description
15	RESERVED	R	0h	Reserved
14	RESERVED	R	0h	Reserved
13	RESERVED	R	0h	Reserved
12	RESERVED	R	0h	Reserved
11	RESERVED	R	0h	Reserved
10	RESERVED	R	0h	Reserved
9	RESERVED	R	0h	Reserved
8	extended_status	R	1h	1b = Extended status information in Register 15 0b = No extended status information in Register 15
7	unidirectional_ability	R	0h	Reserved

Table 8-25. BMSR Register Field Descriptions (continued)

Bit	Field	Type	Reset	Description
6	preamble_supression	R	1h	1b = PHY will accept management frames with preamble suppressed. 0b = PHY will not accept management frames with preamble suppressed
5	aneg_complete	R	0h	Reserved
4	remote_fault	R/W0C	0h	Reserved
3	aneg_ability	R	0h	Reserved
2	link_status	R/W0S	0h	1b = link is up 0b = link down
1	jabber_detect	R/W0C	0h	Reserved
0	extended_capability	R	1h	1b = extended register capabilities 0b = basic register set capabilities only

8.6.2.1.3 PHYID1 Register (Offset = 2h) [Reset = 2000h]

PHYID1 is shown in [Table 8-26](#).

Return to the [Summary Table](#).

Table 8-26. PHYID1 Register Field Descriptions

Bit	Field	Type	Reset	Description
15-0	oui_21_16	R	2000h	

8.6.2.1.4 PHYID2 Register (Offset = 3h) [Reset = A284h]

PHYID2 is shown in [Table 8-27](#).

Return to the [Summary Table](#).

Table 8-27. PHYID2 Register Field Descriptions

Bit	Field	Type	Reset	Description
15-10	oui_5_0	R	28h	
9-4	model_number	R	28h	
3-0	rev_number	R	4h	

8.6.2.1.5 REGCR Register (Offset = Dh) [Reset = 0h]

REGCR is shown in [Table 8-28](#).

Return to the [Summary Table](#).

Table 8-28. REGCR Register Field Descriptions

Bit	Field	Type	Reset	Description
15-14	Extended Register Command	R/W	0h	00b = Address 01b = Data, no post increment 10b = Data, post increment on read and write 11b = Data, post increment on write only
13-5	RESERVED	R	0h	Reserved
4-0	DEVAD	R/W	0h	

8.6.2.1.6 ADDAR Register (Offset = Eh) [Reset = 0h]

ADDAR is shown in [Table 8-29](#).

Return to the [Summary Table](#).

Table 8-29. ADDAR Register Field Descriptions

Bit	Field	Type	Reset	Description
15-0	Address/Data	R/W	0h	

8.6.2.1.7 MII_REG_10 Register (Offset = 10h) [Reset = 4h]

MI_REG_10 is shown in [Table 8-30](#).

Return to the [Summary Table](#).

Table 8-30. MII_REG_10 Register Field Descriptions

Bit	Field	Type	Reset	Description
15-11	RESERVED	R	0h	Reserved
10	signal_detect	R/W0S	0h	1b = Channel ok is set 0b = Channel ok had been reset
9	descr_lock_bit	R/W0S	0h	1b = Descrambler is locked 0b = Descrambler had been locked
8	RESERVED	R	0h	Reserved
7	mii_int_bit		0h	1b = Interrupt pin had been set 0b = Interrupts pin not set
6-4	RESERVED	R	0h	Reserved
3	mii_loopback	R	0h	1b = MII loopback 0b = No MII loopback
2	duplex_mode_env	R	1h	1b = Full duplex 0b = Half duplex
1	RESERVED	R	0h	Reserved
0	link_status_bit	R	0h	1b = link is up 0b = link had been down

8.6.2.1.8 MII_REG_11 Register (Offset = 11h) [Reset = Ah]

MI_REG_11 is shown in [Table 8-31](#).

Return to the [Summary Table](#).

Table 8-31. MII_REG_11 Register Field Descriptions

Bit	Field	Type	Reset	Description
15	dis_clk_125	R/W	0h	1b = stop clk_125 to MAC on IEEE power save mode 0b = keep clk_125 to MAC
14	power_save_mode_en	R/W	0h	
13-12	RESERVED	R	0h	Reserved
11	sgmii_soft_reset	R/WSC	0h	Reset SGMII
10	use_phyad0_as_isolate	R/W	0h	Use PHY ADDRESS 5b0 as isolate
9	channel_debug_mode	R/W	0h	Enable channel debug mode
8	debug_mode	R/W	0h	Enable debug mode
7	RESERVED	R	0h	Reserved
6	cfg_soft_reset_non_clear	R/W	0h	0b = 0x1F = 4000 is self clearing 1b = 0x1F = 4000 is non self clearing
5-4	cfg_reset_time_sel	R/W	0h	00b = 120ns 01b = 32us 10b = 256us 11b = 1024us
3	int_polarity	R/W	1h	1b = Active low 0b = Active high
2	force_interrupt	R/W	0h	1b = Force interrupt pin 0b = Do not force interrupt pin
1	int_en	R/W	1h	1b = Enable interrupts 0b = Disable interrupts
0	RESERVED	R	0h	Reserved

8.6.2.1.9 MII_REG_12 Register (Offset = 12h) [Reset = 0h]

MI_REG_12 is shown in [Table 8-32](#).

Return to the [Summary Table](#).

Table 8-32. MII_REG_12 Register Field Descriptions

Bit	Field	Type	Reset	Description
15	link_qual_int	R	0h	Link quality bad interrupt status
14	energy_det_int	R	0h	Energy det change interrupt status
13	link_int	R	0h	Link status change interrupt status
12	RESERVED	R	0h	Reserved
11	esd_int	R	0h	ESD fault detected interrupt status
10	ms_train_done_int	R	0h	Training done interrupt status
9	RESERVED	R	0h	Reserved
8	RESERVED	R	0h	Reserved
7	link_qual_int_en	R/W	0h	Link quality bad interrupt enable
6	energy_det_int_en	R/W	0h	Energy det change interrupt enable
5	link_int_en	R/W	0h	Link status change interrupt enable
4	unused_int_3	R/W	0h	Reserved
3	esd_int_en	R/W	0h	ESD fault detected interrupt enable
2	ms_train_done_int_en	R/W	0h	Training done interrupt enable
1	unused_int_2	R/W	0h	Reserved
0	unused_int_1	R/W	0h	Reserved

8.6.2.1.10 MII_REG_13 Register (Offset = 13h) [Reset = 0h]

MII_REG_13 is shown in [Table 8-33](#).

Return to the [Summary Table](#).

Table 8-33. MII_REG_13 Register Field Descriptions

Bit	Field	Type	Reset	Description
15	under_volt_int	R	0h	Under volt interrupt status
14	over_volt_int	R	0h	Over volt interrupt status
13	RESERVED	R	0h	Reserved
12	RESERVED	R	0h	Reserved
11	over_temp_int	R	0h	Over temp interrupt status
10	sleep_int	R	0h	Sleep mode change interrupt status
9	pol_change_int	R	0h	Data polarity change interrupt status
8	not_one_hot_int	R	0h	Not one hot interrupt status
7	under_volt_int_en	R/W	0h	Under volt interrupt enable
6	over_volt_int_en	R/W	0h	Over volt interrupt enable
5	unused_int_6	R/W	0h	Reserved
4	unused_int_5	R/W	0h	Reserved
3	over_temp_int_en	R/W	0h	Over temp interrupt enable
2	sleep_int_en	R/W	0h	Sleep mode change interrupt enable
1	pol_change_int_en	R/W	0h	Data Polarity change interrupt enable
0	not_one_hot_int_en	R/W	0h	Not one hot interrupt enable

8.6.2.1.11 MII_REG_16 Register (Offset = 16h) [Reset = 0h]

MII_REG_16 is shown in [Table 8-34](#).

Return to the [Summary Table](#).

Table 8-34. MII_REG_16 Register Field Descriptions

Bit	Field	Type	Reset	Description
15-11	RESERVED	R	0h	Reserved
10	prbs_sync_loss	R/W0C	0h	1b = Prbs lock had been lost 0b = Prbs lock never lost
9	RESERVED	R	0h	Reserved
8	core_pwr_mode	R	0h	1b = Core is in normal power mode 0b = Core is in power down or sleep mode
7	cfg_dig_pcs_loopback	R/W	0h	PCS digital loopback
6-0	loopback_mode	R/W	0h	000001b = PCS loop 000010b = RS loop 000100b = Digital loop 001000B = Analog loop 010000b = Reverse loop

8.6.2.1.12 MII_REG_18 Register (Offset = 18h) [Reset = 8h]

MII_REG_18 is shown in [Table 8-35](#).

Return to the [Summary Table](#).

Table 8-35. MII_REG_18 Register Field Descriptions

Bit	Field	Type	Reset	Description
15	ack_received_int	R	0h	Ack received interrupt status (OAM)
14	tx_valid_clr_int	R	0h	mr_tx_valid clear interrupt status (OAM)
13	RESERVED	R	0h	Reserved
12	RESERVED	R	0h	Reserved
11	por_done_int	R	0h	POR done interrupt status
10	no_frame_int	R	0h	No frame detect interrupt status
9	wake_req_int	R	0h	Wake request interrupt status
8	lps_int	R	0h	LPS interrupt status
7	ack_received_int_en	R/W	0h	Ack received interrupt enable (OAM)
6	tx_valid_clr_int_en	R/W	0h	mr_tx_valid clear interrupt enable (OAM)
5	RESERVED	R	0h	Reserved
4	RESERVED	R	0h	Reserved
3	por_done_int_en	R/W	1h	POR done interrupt enable
2	no_frame_int_en	R/W	0h	No frame detect interrupt enable
1	wake_req_int_en	R/W	0h	Wake request interrupt enable
0	lps_int_en	R/W	0h	LPS interrupt enable

8.6.2.1.13 MII_REG_19 Register (Offset = 19h) [Reset = X]

MII_REG_19 is shown in [Table 8-36](#).

Return to the [Summary Table](#).

Table 8-36. MII_REG_19 Register Field Descriptions

Bit	Field	Type	Reset	Description
15-11	RESERVED	R	0h	Reserved
10	dsp_energy_detect	R	0h	DSP energy detected status
9-5	RESERVED	R	0h	Reserved
4-0	SOR_PHYADDR	R	X	PHY ADDRESS latched from strap

8.6.2.1.14 MII_REG_1E Register (Offset = 1Eh) [Reset = 0h]

MI_REG_1E is shown in [Table 8-37](#).

Return to the [Summary Table](#).

Table 8-37. MII_REG_1E Register Field Descriptions

Bit	Field	Type	Reset	Description
15	tdr_start	R/W/MC	0h	1b = TDR start 0b = No TDR
14	cfg_tdr_auto_run	R/W	0h	1b = TDR start automatically on link down 0b = TDR start manually
13-2	RESERVED	R	0h	Reserved
1	tdr_done	R	0h	TDR done status
0	tdr_fail	R	0h	TDR fail status

8.6.2.1.15 MII_REG_1F Register (Offset = 1Fh) [Reset = 0h]

MI_REG_1F is shown in [Table 8-38](#).

Return to the [Summary Table](#).

Table 8-38. MII_REG_1F Register Field Descriptions

Bit	Field	Type	Reset	Description
15	sw_global_reset	R/W/MC	0h	Hardware reset - Reset digital + register file
14	digital_reset	R/W/MC	0h	Soft reset - Reset only digital core
13	sor_debug_option	R/W	0h	Use sw_global_reset as RESET pin source
12-8	tp_sel_1_9_5	R/W	0h	Test port select[9:5] - Select module
7	standby_mode	R/W	0h	Reserved
6	standby_mode_ch_sel_B_An	R/W	0h	Reserved
5	RESERVED	R	0h	Reserved
4-0	tp_sel_1_4_0	R/W	0h	Test port select[4:0] - Select signals within module

8.6.2.1.16 C_AND_S_STATUS Register (Offset = 180h) [Reset = 0h]

C_AND_S_STATUS is shown in [Table 8-39](#).

Return to the [Summary Table](#).

Table 8-39. C_AND_S_STATUS Register Field Descriptions

Bit	Field	Type	Reset	Description
15	link_up	R	0h	link up defined by CnS
14	link_down	R	0h	link down as defined by CnS
13	phy_ctrl_send_data	R	0h	phy control in send data status
12	link_status	R	0h	link status
11-8	pm_coded_state	R	0h	pm state
7	sel_osc25_clk_n	R	0h	25MHz clock select
6	pll_clk_sel	R	0h	PLL clock select
5	pwr_seq_done	R	0h	Power seq done status
4	slave_ph1_done	R	0h	slave ph1 done status
3	channel_ok	R	0h	channel okay status
2	descr_sync	R	0h	Descrambler lock status
1	loc_rcvr_status	R	0h	Local receiver status

Table 8-39. C_AND_S_STATUS Register Field Descriptions (continued)

Bit	Field	Type	Reset	Description
0	rem_rcvr_status	R	0h	Remote receiver status

8.6.2.1.17 PM_TOP_CFG Register (Offset = 181h) [Reset = 440h]

PM_TOP_CFG is shown in [Table 8-40](#).

Return to the [Summary Table](#).

Table 8-40. PM_TOP_CFG Register Field Descriptions

Bit	Field	Type	Reset	Description
15-12	RESERVED	R	0h	Reserved
11	RESERVED	R	0h	Reserved
10	cfg_lps_mac_pwrndn_en	R/W	1h	Enable power down of mac inf during Low power mode
9	RESERVED	R	0h	Reserved
8	cfg_lps_dbg_mode	R/W	0h	LPS debug mode enable to reduce the sleep request timeout
7-6	cfg_lps_slp_rqst_to	R/W	1h	Sleep request timer threshold. 2b00 = 0.4ms, 2b01 = 1ms, 2b10 = 4ms, 2b11 = 16ms
5-4	RESERVED	R	0h	Reserved
3	pll_gf_reset_reg	R/W	0h	1 = Reset is high 0 = Reset is low
2	force_pll_gf_reset	R/W	0h	1 = Force pll_clk mux reset to value defined in bit[8] 0 = Normal mode
1	pll_clk_sel_reg	R/W	0h	1: select PLL clock 0: select REF clock
0	force_pll_ctrl	R/W	0h	1: force pll_clk_mux selec to value defined in Bit[2] 0: Do not force pll_clk_mux select (Normal)

8.6.2.1.18 CLK_CTRL_CFG Register (Offset = 182h) [Reset = 0h]

CLK_CTRL_CFG is shown in [Table 8-41](#).

Return to the [Summary Table](#).

Table 8-41. CLK_CTRL_CFG Register Field Descriptions

Bit	Field	Type	Reset	Description
15	RESERVED	R	0h	Reserved
14	RESERVED	R	0h	Reserved
13	RESERVED	R	0h	Reserved
12	RESERVED	R	0h	Reserved
11-0	RESERVED	R	0h	Reserved

8.6.2.1.19 LPS_CFG Register (Offset = 183h) [Reset = 0h]

LPS_CFG is shown in [Table 8-42](#).

Return to the [Summary Table](#).

Table 8-42. LPS_CFG Register Field Descriptions

Bit	Field	Type	Reset	Description
15-8	RESERVED	R	0h	Reserved
7	cfg_force_lps_st_en	R/W	0h	Enable force lps state
6-0	cfg_force_lps_st	R/W	0h	Force lps state

8.6.2.1.20 LPS_CFG2 Register (Offset = 18Bh) [Reset = 0h]

LPS_CFG2 is shown in [Table 8-43](#).

Return to the [Summary Table](#).

Table 8-43. LPS_CFG2 Register Field Descriptions

Bit	Field	Type	Reset	Description
15-9	RESERVED	R	0h	Reserved
8	ed_en	R/W	0h	1b = Enable energy detection on MDI 0b = Disable energy detection on MDI
7	sleep_en	R/W	0h	1b = Allow PHY to enter sleep 0b = Do not allow PHY to enter sleep
6	cfg_auto_mode_en_strap	R/WMC,1	0h	LPS autonomous mode enable 1b = PHY enters normal mode on power up 0b = PHY enters standby mode on power up
5	cfg_lps_mon_en_strap	R/W	0h	
4	cfg_lps_sleep_auto	R/W	0h	Reserved
3	cfg_lps_slp_confirm	R/W	0h	Reserved
2	cfg_lps_auto_pwrdn	R/W	0h	Reserved
1	cfg_lps_sleep_en	R/W	0h	Reserved
0	cfg_lps_sm_en	R/W	0h	Reserved

8.6.2.1.21 LPS_CFG3 Register (Offset = 18Ch) [Reset = 0h]

LPS_CFG3 is shown in [Table 8-44](#).

Return to the [Summary Table](#).

Table 8-44. LPS_CFG3 Register Field Descriptions

Bit	Field	Type	Reset	Description
15-8	RESERVED	R	0h	Reserved
7	cfg_lps_pwr_mode_7	R/WMC,0	0h	Reserved
6	cfg_lps_pwr_mode_6	R/WMC,0	0h	Reserved
5	cfg_lps_pwr_mode_5	R/WMC,0	0h	Reserved
4	cfg_lps_pwr_mode_4	R/WMC,0	0h	Set to enter standby mode
3	cfg_lps_pwr_mode_3	R/WMC,0	0h	Reserved
2	cfg_lps_pwr_mode_2	R/WMC,0	0h	Reserved
1	cfg_lps_pwr_mode_1	R/WMC,0	0h	Reserved
0	cfg_lps_pwr_mode_0	R/WMC,0	0h	Set to enter normal mode

8.6.2.1.22 LPS_STATUS Register (Offset = 18Eh) [Reset = 0h]

LPS_STATUS is shown in [Table 8-45](#).

Return to the [Summary Table](#).

Table 8-45. LPS_STATUS Register Field Descriptions

Bit	Field	Type	Reset	Description
15-7	RESERVED	R	0h	Reserved
6-0	status_lps_st	R	0h	Observe LPS state : 0x2 = Standby mode 0x4 = Normal mode

8.6.2.1.23 TDR_STATUS0 Register (Offset = 309h) [Reset = 0h]

TDR_STATUS0 is shown in [Table 8-46](#).

Return to the [Summary Table](#).

Table 8-46. TDR_STATUS0 Register Field Descriptions

Bit	Field	Type	Reset	Description
15-8	peak1_loc	R	0h	Peak 1 location in tap index
7-0	peak0_loc	R	0h	Peak 0 location in tap index

8.6.2.1.24 TDR_STATUS1 Register (Offset = 30Ah) [Reset = 0h]

TDR_STATUS1 is shown in [Table 8-47](#).

Return to the [Summary Table](#).

Table 8-47. TDR_STATUS1 Register Field Descriptions

Bit	Field	Type	Reset	Description
15-8	peak3_loc	R	0h	Peak 3 location in tap index
7-0	peak2_loc	R	0h	Peak 2 location in tap index

8.6.2.1.25 TDR_STATUS2 Register (Offset = 30Bh) [Reset = 0h]

TDR_STATUS2 is shown in [Table 8-48](#).

Return to the [Summary Table](#).

Table 8-48. TDR_STATUS2 Register Field Descriptions

Bit	Field	Type	Reset	Description
15-8	peak0_amp	R	0h	Peak 0 amplitude in echo coeff
7-0	peak4_loc	R	0h	Peak 4 location in tap index

8.6.2.1.26 TDR_STATUS5 Register (Offset = 30Eh) [Reset = 0h]

TDR_STATUS5 is shown in [Table 8-49](#).

Return to the [Summary Table](#).

Table 8-49. TDR_STATUS5 Register Field Descriptions

Bit	Field	Type	Reset	Description
15-5	RESERVED	R	0h	Reserved
4	peak4_sign	R	0h	Peak 4 sign
3	peak3_sign	R	0h	Peak 3 sign
2	peak2_sign	R	0h	Peak 2 sign
1	peak1_sign	R	0h	Peak 1 sign
0	peak0_sign	R	0h	Peak 0 sign

8.6.2.1.27 TDR_TC12 Register (Offset = 30Fh) [Reset = 0h]

TDR_TC12 is shown in [Table 8-50](#).

Return to the [Summary Table](#).

Table 8-50. TDR_TC12 Register Field Descriptions

Bit	Field	Type	Reset	Description
15-14	RESERVED	R	0h	Reserved
13-8	fault_loc	R	0h	See TC12

Table 8-50. TDR_TC12 Register Field Descriptions (continued)

Bit	Field	Type	Reset	Description
7-4	tdr_state	R	0h	See TC12
3-2	RESERVED	R	0h	Reserved
1-0	tdr_activation	R	0h	See TC12

8.6.2.1.28 A2D_REG_05 Register (Offset = 405h) [Reset = 6400h]

A2D_REG_05 is shown in [Table 8-51](#).

Return to the [Summary Table](#).

Table 8-51. A2D_REG_05 Register Field Descriptions

Bit	Field	Type	Reset	Description
15-10	ld_bias_1p0v_sl	R/W	19h	Bits to control the DAC current of LD and hence the swing. 001010b = 400 001011b = 440 001100b = 480 001101b = 520 001110b = 560 001111b = 600 010000b = 640 010001b = 680 010010b = 720 010011b = 760 010100b = 800 010101b = 840 010110b = 880 010111b = 920 011000b = 960 011001b = 1000 011010b = 1040 011011b = 1080 011100b = 1120 011101b = 1160 011110b = 1200
9-0	RESERVED	R	0h	Reserved

8.6.2.1.29 A2D_REG_31 Register (Offset = 41Fh) [Reset = 0h]

A2D_REG_31 is shown in [Table 8-52](#).

Return to the [Summary Table](#).

Table 8-52. A2D_REG_31 Register Field Descriptions

Bit	Field	Type	Reset	Description
15	RESERVED	R	0h	Reserved
14	RESERVED	R	0h	Reserved
13	RESERVED	R	0h	Reserved
12	RESERVED	R	0h	Reserved
11	RESERVED	R	0h	Reserved
10-7	RESERVED	R	0h	Reserved
6-3	RESERVED	R	0h	Reserved
2	RESERVED	R	0h	Reserved
1	RESERVED	R	0h	Reserved
0	RESERVED	R	0h	Reserved

8.6.2.1.30 A2D_REG_40 Register (Offset = 428h) [Reset = 6000h]

A2D_REG_40 is shown in [Table 8-53](#).

Return to the [Summary Table](#).

Table 8-53. A2D_REG_40 Register Field Descriptions

Bit	Field	Type	Reset	Description
15	RESERVED	R	0h	Reserved
14-13	SGMII_TESTMODE	R/W	3h	00b = 1000mV 01b = 1260mV 10b = 900mV 11b = 720mV
12	RESERVED	R	0h	Reserved
11	SGMII_SOP_SON_SLEW_CTRL	R/W	0h	0b = Fast SOP/SON rise/fall time 1b = Slow SOP/SON rise/fall time

Table 8-53. A2D_REG_40 Register Field Descriptions (continued)

Bit	Field	Type	Reset	Description
10	RESERVED	R	0h	Reserved
9-8	RESERVED	R	0h	Reserved
7	RESERVED	R	0h	Reserved
6-1	RESERVED	R	0h	Reserved
0	RESERVED	R	0h	Reserved

8.6.2.1.31 A2D_REG_41 Register (Offset = 429h) [Reset = 0h]

A2D_REG_41 is shown in [Table 8-54](#).

Return to the [Summary Table](#).

Table 8-54. A2D_REG_41 Register Field Descriptions

Bit	Field	Type	Reset	Description
15-11	RESERVED	R	0h	Reserved
10	RESERVED	R	0h	Reserved
9	RESERVED	R	0h	Reserved
8	RESERVED	R	0h	Reserved
7-2	RESERVED	R	0h	Reserved
1	SGMII_IO_LOOPBACK_EN	R/W	0h	1b = Connects RX and TX signals internally to provide internal loopback option without external components.
0	RESERVED	R	0h	Reserved

8.6.2.1.32 A2D_REG_42 Register (Offset = 42Ah) [Reset = 0h]

A2D_REG_42 is shown in [Table 8-55](#).

Return to the [Summary Table](#).

Table 8-55. A2D_REG_42 Register Field Descriptions

Bit	Field	Type	Reset	Description
15-0	SGMII_CDR_TESTMODE_0	R/W	0h	SGMII RX CDR test mode

8.6.2.1.33 A2D_REG_43 Register (Offset = 42Bh) [Reset = 0h]

A2D_REG_43 is shown in [Table 8-56](#).

Return to the [Summary Table](#).

Table 8-56. A2D_REG_43 Register Field Descriptions

Bit	Field	Type	Reset	Description
15-0	SGMII_CDR_TESTMODE_1	R/W	0h	SGMII RX CDR test mode

8.6.2.1.34 A2D_REG_44 Register (Offset = 42Ch) [Reset = 0h]

A2D_REG_44 is shown in [Table 8-57](#).

Return to the [Summary Table](#).

Table 8-57. A2D_REG_44 Register Field Descriptions

Bit	Field	Type	Reset	Description
15	RESERVED	R	0h	Reserved
14	RESERVED	R	0h	Reserved
13	RESERVED	R	0h	Reserved
12	RESERVED	R	0h	Reserved
11	RESERVED	R	0h	Reserved
10	RESERVED	R	0h	Reserved
9	RESERVED	R	0h	Reserved
8	RESERVED	R	0h	Reserved
7	RESERVED	R	0h	Reserved
6	RESERVED	R	0h	Reserved
5	RESERVED	R	0h	Reserved
4	SGMII_DIG_LOOPBACK_EN	R/W	0h	1b = Loops back TX data to RX before the IO
3-1	RESERVED	R	0h	Reserved
0	RESERVED	R	0h	Reserved

8.6.2.1.35 A2D_REG_45 Register (Offset = 42Dh) [Reset = 0h]

A2D_REG_45 is shown in [Table 8-58](#).

Return to the [Summary Table](#).

Table 8-58. A2D_REG_45 Register Field Descriptions

Bit	Field	Type	Reset	Description
15-0	SGMII_TESTOUT	R	0h	SGMII test mode output

8.6.2.1.36 A2D_REG_46 Register (Offset = 42Eh) [Reset = 0h]

A2D_REG_46 is shown in [Table 8-59](#).

Return to the [Summary Table](#).

Table 8-59. A2D_REG_46 Register Field Descriptions

Bit	Field	Type	Reset	Description
15-12	RESERVED	R	0h	Reserved
11	sgmii_calib_watchdog_dis	R/W	0h	By default, SGMII calibration process has a watchdog timer. If calibration is not ended till timer expires, then it is disabled and default value is taken. If this bit is set, then the calibration watchdog timer is disabled.
10-9	sgmii_calib_watchdog_val	R/W	0h	Watchdog timer configuration for SGMII calibration sequence: 00 - If not ended, calibration stops after 32us 01 - If not ended, calibration stops after 48us 10 - If not ended, calibration stops after 64us 11 - If not ended, calibration stops after 128us
8-7	sgmii_calib_avg	R/W	0h	Number of repetitions of COMP_OFFSET_TUNE calibration (the repetitions are for averaging): 00 - a single repetition 01 - 2 repetitions 10 - 4 repetitions 11 - 8 repetitions
6	sgmii_do_calib	R/WSC	0h	SGMII start calibration command (mainly for debug) Please notice: This register is WSC (write-self-clear) and not read-only!
5	SGMII_CDR_LOCK_SL	R	0h	Indicates Sgmii's CDR lock status
4	SGMII_MODE_force_en	R/W	0h	
3	SGMII_INPUT_TERM_EN_force_en	R/W	0h	

Table 8-59. A2D_REG_46 Register Field Descriptions (continued)

Bit	Field	Type	Reset	Description
2	SGMII_OUTPUT_EN_force_en	R/W	0h	
1	SGMII_COMP_OFFSET_TUNE_force_en	R/W	0h	
0	SGMII_DATA_SYNC_SL	R	0h	

8.6.2.1.37 A2D_REG_48 Register (Offset = 430h) [Reset = 960h]

A2D_REG_48 is shown in [Table 8-60](#).

Return to the [Summary Table](#).

Table 8-60. A2D_REG_48 Register Field Descriptions

Bit	Field	Type	Reset	Description
15	RESERVED	R	0h	Reserved
14	RESERVED	R	0h	Reserved
13	RESERVED	R	0h	Reserved
12	DLL_EN	R/W	0h	
11-8	DLL_TX_DELAY_CTRL_SL	R/W	9h	Refer to electrical specification for delay vs code information.
7-4	DLL_RX_DELAY_CTRL_SL	R/W	6h	Refer to electrical specification for delay vs code information.
3-0	RESERVED	R	0h	Reserved

8.6.2.1.38 A2D_REG_66 Register (Offset = 442h) [Reset = 0h]

A2D_REG_66 is shown in [Table 8-61](#).

Return to the [Summary Table](#).

Table 8-61. A2D_REG_66 Register Field Descriptions

Bit	Field	Type	Reset	Description
15	RESERVED	R	0h	Reserved
14-9	esd_event_count	R	0h	Number gives the number of esd events on the copper channel
8	RESERVED	R	0h	Reserved
7-5	RESERVED	R	0h	Reserved
4	RESERVED	R	0h	Reserved
3-0	RESERVED	R	0h	Reserved

8.6.2.1.39 LEDS_CFG_1 Register (Offset = 450h) [Reset = 2610h]

LEDS_CFG_1 is shown in [Table 8-62](#).

Return to the [Summary Table](#).

Table 8-62. LEDS_CFG_1 Register Field Descriptions

Bit	Field	Type	Reset	Description
15	RESERVED	R	0h	
14	leds_bypass_stretching	R/W	0h	LED Signal Stretch
13-12	leds_blink_rate	R/W	2h	Blink Rate for the LED - 00b = 20Hz (50mSec) 01b = 10Hz (100mSec) 10b = 5Hz (200mSec) 11b = 2Hz (500mSec)

Table 8-62. LEDS_CFG_1 Register Field Descriptions (continued)

Bit	Field	Type	Reset	Description
11-8	led_2_option	R/W	6h	0000b = link OK 0001b = link OK + blink on TX/RX activity 0010b = link OK + blink on TX activity 0011b = link OK + blink on RX activity 0100b = link OK + 100Base-T1 Master 0101b = link OK + 100Base-T1 Slave 0110b = TX/RX activity with stretch option 0111b = Reserved 1000b = Reserved 1001b = Link lost (remains on until register 0x1 is read) 1010b = PRBS error latch until cleared by 0x620(1) 1011b = XMI1 TX/RX Error with stretch option
7-4	led_1_option	R/W	1h	0000b = link OK 0001b = link OK + blink on TX/RX activity 0010b = link OK + blink on TX activity 0011b = link OK + blink on RX activity 0100b = link OK + 100Base-T1 Master 0101b = link OK + 100Base-T1 Slave 0110b = TX/RX activity with stretch option 0111b = Reserved 1000b = Reserved 1001b = Link lost (remains on until register 0x1 is read) 1010b = PRBS error (latch until cleared by 0x620(1)) 1011b = XMI1 TX/RX Error with stretch option
3-0	led_0_option	R/W	0h	0000b = link OK 0001b = link OK + blink on TX/RX activity 0010b = link OK + blink on TX activity 0011b = link OK + blink on RX activity 0100b = link OK + 100Base-T1 Master 0101b = link OK + 100Base-T1 Slave 0110b = TX/RX activity with stretch option 0111b = Reserved 1000b = Reserved 1001b = Link lost (remains on until register 0x1 is read) 1010b = PRBS error (latch until cleared by 0x620(1)) 1011b = XMI1 TX/RX Error with stretch option

8.6.2.1.40 LEDS_CFG_2 Register (Offset = 451h) [Reset = 0h]LEDS_CFG_2 is shown in [Table 8-63](#).Return to the [Summary Table](#).**Table 8-63. LEDS_CFG_2 Register Field Descriptions**

Bit	Field	Type	Reset	Description
13-10	RESERVED	R	0h	Reserved
11-9	cfg_ieee_compl_sel	R/W	0h	Observe IEEE Compliance signals in LED_0_GPIO_0, when LED_0_GPIO_CTRL= 'h5 as follows - 000b = loc_rcvr_status 001b = rem_rcvr_status 010b = loc_snr_margin 011b = rem_phy_ready 100b = pma_watchdog_status 101b = link_sync_link_control
8	led_2_drv_en	R/W	0h	LED_2 Drive Enable, When set, drives the value as per LED_2_DRV_VAL
7	led_2_drv_val	R/W	0h	LED_2 Drive Value, when LED_2_DRV_EN is set
6	led_2_polarity	R/W	0h	LED_2 polarity
5	led_1_drv_en	R/W	0h	LED_1 Drive Enable, When set, drives the value as per LED_1_DRV_VAL
4	led_1_drv_val	R/W	0h	LED_1 Drive Value, when LED_1_DRV_EN is set
3	led_1_polarity	R/W	0h	LED_1 polarity
2	led_0_drv_en	R/W	0h	LED_0 Drive Enable, When set, drives the value as per LED_0_DRV_VAL
1	led_0_drv_val	R/W	0h	LED_0 Drive Value, when LED_0_DRV_EN is set
0	led_0_polarity	R/W	0h	LED_0 polarity

8.6.2.1.41 IO_MUX_CFG_1 Register (Offset = 452h) [Reset = 0h]IO_MUX_CFG_1 is shown in [Table 8-64](#).Return to the [Summary Table](#).

Table 8-64. IO_MUX_CFG_1 Register Field Descriptions

Bit	Field	Type	Reset	Description
15-14	RESERVED	R	0h	Reserved
13-11	RESERVED	R	0h	Reserved
10-8	led_1_gpio_ctrl	R/W	0h	Controls the output of LED_1 IO - 000b = LED_1 (default: link OK + blink on TX/RX activity) 001b = Reserved 010b = RGMII data match indication 011b = Under-Voltage indication 100b = Interrupt 101b = IEEE compliance signals 110b = constant 0 111b = constant 1
7-6	RESERVED	R	0h	Reserved
5-3	RESERVED	R	0h	Reserved
2-0	led_0_gpio_ctrl	R/W	0h	Controls the output of LED_0 IO: 000b = LED_0 (default: LINK) 001b = Reserved 010b = RGMII data match indication 011b = Under-Voltage indication 100b = Interrupt 101b = IEEE compliance signals (see 0x451[11:9]) 110b = constant 0 111b = constant 1

8.6.2.1.42 IO_MUX_CFG_2 Register (Offset = 453h) [Reset = 1h]

IO_MUX_CFG_2 is shown in [Table 8-65](#).

Return to the [Summary Table](#).

Table 8-65. IO_MUX_CFG_2 Register Field Descriptions

Bit	Field	Type	Reset	Description
15-6	RESERVED	R	0h	Reserved
5-3	clk_o_clk_source	R/W	0h	Clock Observable in CLK_O pin - 000b = xi_osc_25m_1p0v_dl (25MHz crystal output - from analog) 001b = Reserved 010b = Reserved 011b = 125MHz clock 100b = 125MHz clock 101b = Reserved 110b = Reserved 111b = Reserved
2-0	clk_o_gpio_ctrl	R/W	1h	Controls the output of CLK_O IO - 000b = LED_2 (default: TX/RX activity with stretch option(LED_2_OPTION=0x6) 001b = Clock out (see 0x453[5:3]) 010b = RGMII data match indication 011b = Under-Voltage indication 100b = constant 0 101b = constant 0 110b = constant 0 111b = constant 1

8.6.2.1.43 IO_CONTROL_1 Register (Offset = 454h) [Reset = 0h]

IO_CONTROL_1 is shown in [Table 8-66](#).

Return to the [Summary Table](#).

Table 8-66. IO_CONTROL_1 Register Field Descriptions

Bit	Field	Type	Reset	Description
15-0	io_control_1	R/W	0h	IO_CONTROL_1 : IO reflects the value written on this register when enabled IO_OE_N_FORCE_CTRL=1 and IO_OE_N_VALUE=0 If 0 is written, IO will be forced to output LOW. If 1 is written, IO will be forced to output HIGH. The following is the bit position for pads. 0=LED_0_GPIO_0; 1=LED_1_GPIO_1; 2=CLKOUT_GPIO_2; 3=INT_N; 4=RESERVED; 5=RESERVED; 6=INH; 7=TX_CLK; 8=TX_CTRL; 9=TX_D0; 10=TX_D1; 11=TX_D2; 12=TX_D3; 13=RX_CLK; 14=RX_CTRL; 15=RX_D0;

8.6.2.1.44 IO_CONTROL_2 Register (Offset = 455h) [Reset = 0h]

IO_CONTROL_2 is shown in [Table 8-67](#).

Return to the [Summary Table](#).

Table 8-67. IO_CONTROL_2 Register Field Descriptions

Bit	Field	Type	Reset	Description
15-14	RESERVED	R	0h	
13-9	cfg_other_impedance	R/W	0h	Slew Rate Control for CLKOUT - 00000b = Default rise/fall time 00001b = Slower rise/fall time 00010b = Faster rise/fall time
8-7	pupd_value	R/W	0h	IO Test mode - pullup/pull down : 00b = No pull (HiZ) 01b = PullUP 10b = PullDown 11b = PullUp/PullDown (Both Enabled)
6	pupd_force_cntl	R/W	0h	IO Test mode pull up/down override functional pull.
5	io_oe_n_value	R/W	0h	IO Test mode direction, related to IO_OE_N_FORCE_CTRL
4	io_oe_n_force_ctrl	R/W	0h	IO Test mode (alternate to BSR). The IO direction is set by IO_OE_N_VALUE and value is set by IO_CONTROL_1/2
3-0	io_control_2	R/W	0h	IO_CONTROL_2 : IO reflects the value written on this register when enabled IO_OE_N_FORCE_CTRL=1 and IO_OE_N_VALUE=0 If 0 is written, IO will be forced to output LOW. If 1 is written, IO will be forced to output HIGH. The following is the bit position for pads. 0=RX_D1; 1=RX_D2; 2=RX_D3; 3=STRP_1;

8.6.2.1.45 IO_CONTROL_3 Register (Offset = 456h) [Reset = 100h]

IO_CONTROL_3 is shown in [Table 8-68](#).

Return to the [Summary Table](#).

Table 8-68. IO_CONTROL_3 Register Field Descriptions

Bit	Field	Type	Reset	Description
15-10	RESERVED	R	0h	Reserved
9-5	cfg_mac_rx_impedance	R/W	8h	Slew Rate Control for RGMII pads - 01010b = Medium Slew (OA tr/td compliant, max tr/td = 1ns) 01011b = Slowest Slew (For low emissions, max tr/td = 1.2ns) 01000b = Default mode (rgmii tr/td compliant, max tr/td=750ps)
4-0	RESERVED	R	0h	Reserved

8.6.2.1.46 IO_STATUS_1 Register (Offset = 457h) [Reset = 0h]

IO_STATUS_1 is shown in [Table 8-69](#).

Return to the [Summary Table](#).

Table 8-69. IO_STATUS_1 Register Field Descriptions

Bit	Field	Type	Reset	Description
15-0	io_status_1	R	0h	IO_STATUS_1 : Register reflects the IO value, when enabled IO_OE_N_FORCE_CTRL=1 and IO_OE_N_VALUE=1 If 0 is read, IO is connected LOW at pin. If 1 is read, IO is connected HIGH at pin. The following is the bit position for each pad. 0=LED_0_GPIO_0; 1=LED_1_GPIO_1; 2=CLKOUT_GPIO_2; 3=INT_N; 4=RESERVED; 5=RESERVED; 6=INH; 7=TX_CLK; 8=TX_CTRL; 9=TX_D0; 10=TX_D1; 11=TX_D2; 12=TX_D3; 13=RX_CLK; 14=RX_CTRL; 15=RX_D0;

8.6.2.1.47 IO_STATUS_2 Register (Offset = 458h) [Reset = 0h]

IO_STATUS_2 is shown in [Table 8-70](#).

Return to the [Summary Table](#).

Table 8-70. IO_STATUS_2 Register Field Descriptions

Bit	Field	Type	Reset	Description
15-4	RESERVED	R	0h	
3-0	io_status_2	R	0h	IO_STATUS_2 : Register reflects the IO value, when enabled IO_OE_N_FORCE_CTRL=1 and IO_OE_N_VALUE=1 If 0 is read, IO is connected LOW at pin. If 1 is read, IO is connected HIGH at pin. The following is the bit position for each pad. 0=RX_D1; 1=RX_D2; 2=RX_D3; 3=STRP_1;

8.6.2.1.48 IO_CONTROL_4 Register (Offset = 459h) [Reset = 0h]

IO_CONTROL_4 is shown in [Table 8-71](#).

Return to the [Summary Table](#).

Table 8-71. IO_CONTROL_4 Register Field Descriptions

Bit	Field	Type	Reset	Description
15-0	io_input_mode	R/W	0h	Each bit configures one pin into input mode as per mapping below - 0=LED_0_GPIO_0; 1=LED_1_GPIO_1; 2=CLKOUT_GPIO_2; 3=INT_N; 4=TX_CLK; 5=TX_CTRL; 6=TX_D0; 7=TX_D1; 8=TX_D2; 9=TX_D3; 10=RX_CLK; 11=RX_CTRL; 12=RX_D0; 13=RX_D1; 14=RX_D2; 15=RX_D3

8.6.2.1.49 IO_CONTROL_5 Register (Offset = 45Ah) [Reset = 0h]

IO_CONTROL_5 is shown in [Table 8-72](#).

Return to the [Summary Table](#).

Table 8-72. IO_CONTROL_5 Register Field Descriptions

Bit	Field	Type	Reset	Description
15-0	io_output_mode	R/W	0h	Each bit configures one pin into output mode as per mapping below - 0=LED_0_GPIO_0; 1=LED_1_GPIO_1; 2=CLKOUT_GPIO_2; 3=INT_N; 4=TX_CLK; 5=TX_CTRL; 6=TX_D0; 7=TX_D1; 8=TX_D2; 9=TX_D3; 10=RX_CLK; 11=RX_CTRL; 12=RX_D0; 13=RX_D1; 14=RX_D2; 15=RX_D3

8.6.2.1.50 SOR_VECTOR_1 Register (Offset = 45Dh) [Reset = 0h]

SOR_VECTOR_1 is shown in [Table 8-73](#).

Return to the [Summary Table](#).

Table 8-73. SOR_VECTOR_1 Register Field Descriptions

Bit	Field	Type	Reset	Description
15	RGMII_TX_SHIFT	R	0h	0x0 = TX shift disabled 0x1 = TX shift enabled
14	RGMII_RX_SHIFT	R	0h	0x0 = RX shift disabled 0x1 = RX shift enabled
13	SGMII_EN	R	0h	0x0 = SGMII disabled 0x1 = SGMII enabled
12	RGMII_EN	R	0h	0x0 = RGMII disabled 0x1 = RGMII enabled
11-9	TEST_MODE	R	0h	
8-6	MAC_MODE	R	0h	0x0 = SGMII 0x1 = Reserved 0x2 = Reserved 0x3 = Reserved 0x4 = RGMII align 0x5 = RGMII TX shift 0x6 = RGMII TX and RX shift 0x7 = RGMII RX shift
5	MAS/SLV	R	0h	0x0 = Slave 0x1 = Master

Table 8-73. SOR_VECTOR_1 Register Field Descriptions (continued)

Bit	Field	Type	Reset	Description
4-0	PHY_AD	R	0h	0x0 = PHY address 0 0x4 = PHY address 4 0x5 = PHY address 5 0x8 = PHY address 8 0xA = PHY address A 0xC = PHY address C 0xD = PHY address D 0xE = PHY address E 0xF = PHY address F

8.6.2.1.51 SOR_VECTOR_2 Register (Offset = 45Eh) [Reset = 0h]

SOR_VECTOR_2 is shown in [Table 8-74](#).

Return to the [Summary Table](#).

Table 8-74. SOR_VECTOR_2 Register Field Descriptions

Bit	Field	Type	Reset	Description
0	AUTO/MANAGED	R	0h	0x0 = Autonomous mode enabled 0x1 = Managed mode enabled

8.6.2.1.52 REV_ID Register (Offset = 466h) [Reset = 0h]

REV_ID is shown in [Table 8-75](#).

Return to the [Summary Table](#).

Table 8-75. REV_ID Register Field Descriptions

Bit	Field	Type	Reset	Description
15-4	RESERVED	R	0h	Reserved
3-0	si_rev_id	R	0h	Internal revision ID

8.6.2.1.53 MONITOR_CTRL1 Register (Offset = 467h) [Reset = 12h]

MONITOR_CTRL1 is shown in [Table 8-76](#).

Return to the [Summary Table](#).

Table 8-76. MONITOR_CTRL1 Register Field Descriptions

Bit	Field	Type	Reset	Description
15-8	cfg_dc_offset_2c	R/W	0h	Analog control
7-6	cfg_cic_gain12_arith	R/W	0h	Analog control
5-3	cfg_cic_gain2	R/W	2h	Analog control
2-0	cfg_cic_gain1	R/W	2h	Analog control

8.6.2.1.54 MONITOR_CTRL2 Register (Offset = 468h) [Reset = 920h]

MONITOR_CTRL2 is shown in [Table 8-77](#).

Return to the [Summary Table](#).

Table 8-77. MONITOR_CTRL2 Register Field Descriptions

Bit	Field	Type	Reset	Description
15	cfg_bypass_reset_sensor_val	R/W	0h	When cfg_bypass_fsm is 1, use this register to keep sensor in reset
14-12	cfg_rd_data	R/W	0h	To read out monitor adc output through MDIO for debug
11-9	cfg_dec_factor_sensors	R/W	4h	Analog control
8-6	cfg_dec_factor_gain_calib	R/W	4h	Analog control
5-3	cfg_dec_factor_dc_calib	R/W	4h	Analog control

Table 8-77. MONITOR_CTRL2 Register Field Descriptions (continued)

Bit	Field	Type	Reset	Description
2-0	cfg_bypass_sel_num	R/W	0h	When cfg_bypass_fsm is 1, use this register to select the sensor

8.6.2.1.55 MONITOR_CTRL4 Register (Offset = 46Ah) [Reset = 94h]

MONITOR_CTRL4 is shown in [Table 8-78](#).

Return to the [Summary Table](#).

Table 8-78. MONITOR_CTRL4 Register Field Descriptions

Bit	Field	Type	Reset	Description
15-9	RESERVED	R	0h	RESERVED
8	cfg_hist_clr	R/W	0h	CFG_HIST_CLR
7	cfg_discard_sample_num	R/W	1h	Number of samples to be discarded before starting averaging - 0b = 2 samples 1b = 4 samples
6	cfg_avg_sample_num	R/W	0h	Number of samples for calculating the average before storing in history - 0b = 2 samples 1b = 4 samples
5-4	cfg_adc_clk_div	R/W	1h	Config options to select frequency of monitor adc clock - 00b = 12.5MHz 01b = 6.25MHz 10b = 3.125MHz 11b = Reserved
3	cfg_force_start	R/W	0h	Set to force start sensor monitor FSM even if link is not established
2	cfg_reset	R/W	1h	0b = Enable the monitor 1b = Monitor is held in reset state At any point of time, if the signal is changed to 1, the module abruptly goes to reset state
1	periodic	R/W	0h	0b = Monitor is enabled only when start is set for one iteration 1b = Monitor is enabled for periodic iteration
0	start	R/WSC	0h	Start indication for sensor monitor FSM, self clearing

8.6.2.1.56 MONITOR_STAT1 Register (Offset = 47Bh) [Reset = 0h]

MONITOR_STAT1 is shown in [Table 8-79](#).

Return to the [Summary Table](#).

Table 8-79. MONITOR_STAT1 Register Field Descriptions

Bit	Field	Type	Reset	Description
15-0	stat_rd_data	R	0h	STAT_RD_DATA

8.6.2.1.57 SYNC_LINK_CONTROL_CFG Register (Offset = 509h) [Reset = 0h]

SYNC_LINK_CONTROL_CFG is shown in [Table 8-80](#).

Return to the [Summary Table](#).

Table 8-80. SYNC_LINK_CONTROL_CFG Register Field Descriptions

Bit	Field	Type	Reset	Description
15-12	RESERVED	R	0h	Reserved
11	RESERVED	R	0h	Reserved
10	RESERVED	R	0h	Reserved
9-2	RESERVED	R	0h	Reserved
1	RESERVED	R	0h	Reserved
0	RESERVED	R	0h	Reserved

8.6.2.1.58 BREAK_LINK_TIMER Register (Offset = 50Ah) [Reset = 1000h]

BREAK_LINK_TIMER is shown in [Table 8-81](#).

Return to the [Summary Table](#).

Table 8-81. BREAK_LINK_TIMER Register Field Descriptions

Bit	Field	Type	Reset	Description
15-14	RESERVED	R	0h	Reserved
13	RESERVED	R	0h	Reserved
12	cfg_fifo_reset_in_break_link	R/W	1h	Allow ADC FIFO to be in reset during break link timer
11	cfg_slave_send_s_32_mode	R/W	0h	Enable mode where Slave PHY sends SEND_S signalling for a fixed 32 times once it has detected SEND_S Note : Should be enabled only if 0x509[10] is not set 0h = Follow IEEE state machine 1h = Enable slave to send SEND_S 32 times
10-0	RESERVED	R	0h	Reserved

8.6.2.1.59 LPS_CONTROL_1 Register (Offset = 514h) [Reset = 8E3h]

LPS_CONTROL_1 is shown in [Table 8-82](#).

Return to the [Summary Table](#).

Table 8-82. LPS_CONTROL_1 Register Field Descriptions

Bit	Field	Type	Reset	Description
15-12	RESERVED	R	0h	Reserved
11-9	cfg_tx_wake_cg	R/W	4h	Control code to send on Tx for wake indication
8-6	cfg_tx_sleep_cg	R/W	3h	Control code to send on Tx for sleep indication
5-3	cfg_rx_wake_cg	R/W	4h	Control code to expect on Rx for wake indication
2-0	cfg_rx_sleep_cg	R/W	3h	Control code to expect on Rx for sleep indication

8.6.2.1.60 LPS_CONTROL_2 Register (Offset = 515h) [Reset = 808h]

LPS_CONTROL_2 is shown in [Table 8-83](#).

Return to the [Summary Table](#).

Table 8-83. LPS_CONTROL_2 Register Field Descriptions

Bit	Field	Type	Reset	Description
15	RESERVED	R	0h	Reserved
14-8	cfg_wake_cg_cnt_th	R/W	8h	Number of continuous expected wake code groups required to acknowledge and set LPS wake command received.
7	RESERVED	R	0h	Reserved
6-0	cfg_sleep_cg_cnt_th	R/W	8h	Number of continuous expected sleep code groups required to acknowledge and set LPS sleep command received.

8.6.2.1.61 MAXWAIT_TIMER Register (Offset = 518h) [Reset = 17CEh]

MAXWAIT_TIMER is shown in [Table 8-84](#).

Return to the [Summary Table](#).

Table 8-84. MAXWAIT_TIMER Register Field Descriptions

Bit	Field	Type	Reset	Description
15-0	cfg_maxwait_timer_init	R/W	17CEh	Maxwait timer value in us (value internally multiplied by 16)

8.6.2.1.62 PHY_CTRL_1G Register (Offset = 519h) [Reset = 3Dh]

PHY_CTRL_1G is shown in [Table 8-85](#).

Return to the [Summary Table](#).

Table 8-85. PHY_CTRL_1G Register Field Descriptions

Bit	Field	Type	Reset	Description
15	RESERVED	R	0h	Reserved
14	cfg_phy_ctrl_fallback_on_energy_lost_loc_rcvr	R/W	0h	Allow phy control to go from TRAINING to COUNTDOWN to SILENT on energy lost and loc_rcvr lock Note : Should be enabled only if 0x519[13] is disabled
13	cfg_phy_ctrl_fallback_on_energy_lost	R/W	0h	Allow phy control to go from TRAINING to COUNTDOWN to SILENT on energy lost Note : Should be enabled only if 0x519[14] is disabled
12	cfg_bypass_dsp_reset	R/W	0h	Bypass dsp reset from pcs
11	cfg_force_link_stat_val	R/W	0h	Forced link status value Valid only if 0x519[10] is set
10	cfg_force_link_stat	R/W	0h	Enable forcing link status value
9	cfg_link_control_override_val	R/W	0h	Override Value for link control (only valid is autoneg is enabled) Valid only if 0x519[8] is set
8	cfg_link_control_override_en	R/W	0h	Override Enable for link control (only valid is autoneg is enabled) 0h = Link_control override disable 1h = Link_control override enable
7-0	cfg_minwait_timer_init	R/W	3Dh	Minwait timer value in us (value internally multiplied by 16)

8.6.2.1.63 TEST_MODE Register (Offset = 531h) [Reset = 0h]

TEST_MODE is shown in [Table 8-86](#).

Return to the [Summary Table](#).

Table 8-86. TEST_MODE Register Field Descriptions

Bit	Field	Type	Reset	Description
15-9	RESERVED	R	0h	Reserved
8	cfg_test_mode4_tx_order	R/W	0h	Order of symbols to be transmitted in Test mode 4 0h = T1 followed by T2 1h = T2 followed by T1
7-0	cfg_test_mode_7_data	R/W	0h	GMII data to transmit in Test mode 7

8.6.2.1.64 LINK_QUAL_1 Register (Offset = 543h) [Reset = 0h]

LINK_QUAL_1 is shown in [Table 8-87](#).

Return to the [Summary Table](#).

Table 8-87. LINK_QUAL_1 Register Field Descriptions

Bit	Field	Type	Reset	Description
15-8	RESERVED	R	0h	Reserved
7-0	link_training_time	R	0h	Link training time in ms (TC12)

8.6.2.1.65 LINK_QUAL_2 Register (Offset = 544h) [Reset = 0h]

LINK_QUAL_2 is shown in [Table 8-88](#).

Return to the [Summary Table](#).

Table 8-88. LINK_QUAL_2 Register Field Descriptions

Bit	Field	Type	Reset	Description
15-8	remote_receiver_time	R	0h	Remote receiver time in ms (TC12)
7-0	local_receiver_time	R	0h	Local receiver time in ms (TC12)

8.6.2.1.66 LINK_DOWN_LATCH_STAT Register (Offset = 545h) [Reset = 0h]

LINK_DOWN_LATCH_STAT is shown in [Table 8-89](#).

Return to the [Summary Table](#).

Table 8-89. LINK_DOWN_LATCH_STAT Register Field Descriptions

Bit	Field	Type	Reset	Description
15-6	RESERVED	R	0h	Reserved
5	channel_ok_ll	R/W0C	0h	1b = Channel ok was never de-asserted 0b = Channel ok was de-asserted
4	link_fail_inhibit_lh	R/W0C	0h	1b = Link fail inhibit assertion was reported 0b = Link fail inhibit assertion was never reported
3	send_s_sigdet_lh	R/W0C	0h	1b = Send s sigdet assertion was reported 0b = Send s sigdet assertion was never reported
2	hi_rfer_lh	R/W0C	0h	1b = High ri rfer assertion was reported 0b = High ri rfer assertion was never reported
1	block_lock_ll	R/W0S	0h	1b = Block lock de-assertion was never reported 0b = Block lock de-assertion was never reported
0	pma_watchdog_ll	R/W0S	0h	1b = Low pma watchdog was never reported 0b = Low pma watchdof was reported

8.6.2.1.67 LINK_QUAL_3 Register (Offset = 547h) [Reset = 0h]

LINK_QUAL_3 is shown in [Table 8-90](#).

Return to the [Summary Table](#).

Table 8-90. LINK_QUAL_3 Register Field Descriptions

Bit	Field	Type	Reset	Description
15-10	link_loss_cnt	R	0h	Link loss count since last power cycle (TC12)
9-0	link_fail_cnt	R	0h	Link fail without link loss count since last power cycle (TC12)

8.6.2.1.68 LINK_QUAL_4 Register (Offset = 548h) [Reset = 0h]

LINK_QUAL_4 is shown in [Table 8-91](#).

Return to the [Summary Table](#).

Table 8-91. LINK_QUAL_4 Register Field Descriptions

Bit	Field	Type	Reset	Description
15-1	RESERVED	R	0h	Reserved
0	comm_ready	R	0h	Communication ready status (TC12)

8.6.2.1.69 PMA_WATCHDOG Register (Offset = 559h) [Reset = 51h]

PMA_WATCHDOG is shown in [Table 8-92](#).

Return to the [Summary Table](#).

Table 8-92. PMA_WATCHDOG Register Field Descriptions

Bit	Field	Type	Reset	Description
15-7	RESERVED	R	0h	Reserved
6	cfg_pma_watchdog_force_val	R/W	1h	Force value for pma watchdog
5	cfg_pma_watchdog_force_en	R/W	0h	Enable forcing pma watchdog
4	cfg_ieee_watchdog_en	R/W	1h	1 : watchdog counters are started after link up 0: TBD 0h = TBD 1h = watchdog counters are started after link up
3-0	cfg_watchdog_cnt_clr_th	R/W	1h	Number of 0, +1, -1 symbols to be seen in their respective watchdog counter window to prevent them for asserting pma_watchdog_status

8.6.2.1.70 DATA_SCR_CFG Register (Offset = 55Ah) [Reset = 0h]

DATA_SCR_CFG is shown in [Table 8-93](#).

Return to the [Summary Table](#).

Table 8-93. DATA_SCR_CFG Register Field Descriptions

Bit	Field	Type	Reset	Description
15	RESERVED	R	0h	Reserved
14-6	cfg_ecc_error	R/W	0h	9 bit error val xored to memory data input for ECC testing
5	cfg_ecc_corrupt	R/W	0h	Enable corruption of memory data for ECC testing
4	cfg_rx_delay_data_scr	R/W	0h	Delay generation of rx descrambler symbols by 1 bit 0h = Do not delay generation of rx descrambler symbols by 1 bit 1h = Delay generation of rx descrambler symbols by 1 bit
3	cfg_tx_delay_data_scr	R/W	0h	Delay generation of tx scrambler symbols by 1 bit 0h = Do not delay generation of tx scrambler symbols by 1 bit 1h = Delay generation of tx scrambler symbols by 1 bit
2	cfg_rx_data_scr_order_inv	R/W	0h	Enable to generate rx descrambler symbols from S[0] instead of S[14] Valid only if LPs 0x55A[1] is set (TI-TI link) 0h = Use S[14] as rx descrambler symbols 1h = Use S[0] as rx descrambler symbols
1	cfg_tx_data_scr_order_inv	R/W	0h	Enable to generate tx scrambler symbols from S[0] instead of S[14] Valid only if LPs 0x55A[2] is set (TI-TI link) 0h = Use S[14] as tx scrambler symbols 1h = Use S[0] as tx scrambler symbols
0	cfg_data_scr_bypass	R/W	0h	Bypass data scrambler on Tx as well as Rx path 0h = Do not bypass data scramblers 1h = Bypass data scramblers

8.6.2.1.71 SYMB_POL_CFG Register (Offset = 55Bh) [Reset = 0h]

SYMB_POL_CFG is shown in [Table 8-94](#).

Return to the [Summary Table](#).

Table 8-94. SYMB_POL_CFG Register Field Descriptions

Bit	Field	Type	Reset	Description
15-5	RESERVED	R	0h	Reserved

Table 8-94. SYMB_POL_CFG Register Field Descriptions (continued)

Bit	Field	Type	Reset	Description
4	cfg_slave_auto_pol_correction_en	R/W	0h	Correct tx polarity for slave based on received polarity 0h = Slave tx polarity independent of slave rx polarity 1h = Slave tx polarity to match received polarity
3	cfg_rx_symb_order_inv	R/W	0h	Order of received symbols S0 to S6 reversed to S6 to S0 Valid only if LPs 0x55B[1] is set (TI-TI link) 0h = Order of received symbols S0 to S6 unchanged 1h = Order of received symbols S0 to S6 reversed to S6 to S0
2	cfg_rx_symb_pol_inv	R/W	0h	Invert polarity of received symbols 0h = Unchanged polarity of received symbols 1h = Invert polarity of received symbols
1	cfg_tx_symb_order_inv	R/W	0h	Order of transmit symbols S0 to S6 reversed to S6 to S0 Valid only if LPs 0x55B[3] is set (TI-TI link) 0h = Order of transmit symbols S0 to S6 unchanged 1h = Order of transmit symbols S0 to S6 reversed to S6 to S0
0	cfg_tx_symb_pol_inv	R/W	0h	Invert polarity of transmit symbols 0h = Unchanged polarity of transmit symbols 1h = Invert polarity of transmit symbols

8.6.2.1.72 OAM_CFG Register (Offset = 55Ch) [Reset = 0h]

OAM_CFG is shown in [Table 8-95](#).

Return to the [Summary Table](#).

Table 8-95. OAM_CFG Register Field Descriptions

Bit	Field	Type	Reset	Description
15-2	RESERVED	R	0h	Reserved
1	cfg_rx_oam_crc_data_in_order	R/W	0h	Reverse order of data input to CRC checker in rx oam to MSB first 0h = Order of data input to CRC checker in rx oam is LSB first 1h = Order of data input to CRC checker in rx oam is MSB first
0	cfg_tx_oam_crc_data_in_order	R/W	0h	Reverse order of data input to CRC calculator in tx oam to MSB first 0h = Order of data input to CRC calculator in tx oam is LSB first 1h = Order of data input to CRC calculator in tx oam is MSB first

8.6.2.1.73 TEST_MEM_CFG Register (Offset = 561h) [Reset = 17A0h]

TEST_MEM_CFG is shown in [Table 8-96](#).

Return to the [Summary Table](#).

Table 8-96. TEST_MEM_CFG Register Field Descriptions

Bit	Field	Type	Reset	Description
15-13	RESERVED	R	0h	Reserved
12-6	cfg_wait_time_xcorr_wen	R/W	5Eh	Wait timer after TX_SEND_S after which testmem is written on energy fall Note : Valid only if 0x561[3] is set
5	cfg_xcorr_dbg_sel	R/W	1h	0b = Select xcorr from aligned detector to write to test mem 1b = Select xcorr from shifted detector to write to test mem Note : Valid only if 0x561[3] is set
4	cfg_send_s_infinite_loop	R/W	0h	enable transmitting infinite send_s sequence. For send_s debug. Valid only in master and when 0x56A[15] is set. 0h = disable infinite send_s mode 1h = enable infinite send_s mode
3	cfg_xcorr_dbg_test_mem	R/W	0h	enabled xcorr debug for send_s. Valid only if 0x561[0] is 1b0 0h = Normal send_s debug. Refer to 0x561[1] 1h = Enabled xcorr debug

Table 8-96. TEST_MEM_CFG Register Field Descriptions (continued)

Bit	Field	Type	Reset	Description
2	cfg_ecc_en	R/W	0h	Enable ECC logic for RS decoder memory 0h = ECC encoding/decoding is disabled 1h = ECC encoding/decoding is enabled
1	cfg_test_mem_sigdet_debug	R/W	0h	Enable sigdet debug mode in test mem send s mode Valid only if 0x561[0] is 1b0 0h = Test mem written in send s mode only on state transition 1h = Enable sigdet debug mode in test mem send s mode
0	cfg_pcs_test_mem_mode	R/W	0h	Choose send s or train rx test mem mode 0h = Send s info on test mem 1h = Train rx info on test mem

8.6.2.1.74 FORCE_CTRL1 Register (Offset = 573h) [Reset = 0h]

FORCE_CTRL1 is shown in [Table 8-97](#).

Return to the [Summary Table](#).

Table 8-97. FORCE_CTRL1 Register Field Descriptions

Bit	Field	Type	Reset	Description
15-9	RESERVED	R	0h	Reserved
8	cfg_force_link_sync_state_en	R/W	0h	Force link sync state enable
7-0	cfg_force_link_sync_state_val	R/W	0h	Force link sync state value

8.6.2.1.75 MBIST_CTRL Register (Offset = 580h) [Reset = 0h]

MBIST_CTRL is shown in [Table 8-98](#).

Return to the [Summary Table](#).

Table 8-98. MBIST_CTRL Register Field Descriptions

Bit	Field	Type	Reset	Description
15-7	RESERVED	R	0h	Reserved
6	dftreadb_0	R/W	0h	
5	dftreada_0	R/W	0h	
4	test_resume_h	R/W	0h	
3	rst_l	R/W	0h	
2	test_h	R/W	0h	
1	tmb_0	R/W	0h	
0	tma_0	R/W	0h	

8.6.2.1.76 MBIST_STAT Register (Offset = 581h) [Reset = 0h]

MBIST_STAT is shown in [Table 8-99](#).

Return to the [Summary Table](#).

Table 8-99. MBIST_STAT Register Field Descriptions

Bit	Field	Type	Reset	Description
15-3	RESERVED	R	0h	Reserved
2	fail_h_0	R	0h	
1	tst_done	R	0h	

Table 8-99. MBIST_STAT Register Field Descriptions (continued)

Bit	Field	Type	Reset	Description
0	start_retention_h	R	0h	

8.6.2.1.77 RGMII_CTRL Register (Offset = 600h) [Reset = 120h]

RGMII_CTRL is shown in [Table 8-100](#).

Return to the [Summary Table](#).

Table 8-100. RGMII_CTRL Register Field Descriptions

Bit	Field	Type	Reset	Description
15-10	RESERVED	R	0h	Reserved
9-7	rgmii_rx_half_full_th	R/W	2h	RGMII RX sync FIFO half full threshold
6-4	rgmii_tx_half_full_th	R/W	2h	RGMII TX sync FIFO half full threshold
3	rgmii_tx_if_en	R/W	0h	RGMII enable bit Default from strap 0h = RGMII disable 1h = RGMII enable
2	invert_rgmii_txd	R/W	0h	Invert RGMII Tx wire order - full swap [3:0] to [0:3] 0h = Keep RGMII Tx wire order same - [3: 1h = Invert RGMII Tx wire order - [3:
1	invert_rgmii_rxd	R/W	0h	Invert RGMII Rx wire order - full swap [3:0] to [0:3] 0h = Keep RGMII Rx wire order same - [3: 1h = Invert RGMII Rx wire order - [3:
0	sup_tx_err_fd	R/W	0h	1: suppress tx_err in full duplex mode when tx_en set to zero 0: allow tx_err assertion to PHY when tx_en set to zero (this bit can disable the TX_ERR indication input) 0h = allow tx_err assertion to PHY when tx_en set to zero 1h = suppress tx_err in full duplex mode when tx_en set to zero

8.6.2.1.78 RGMII_FIFO_STATUS Register (Offset = 601h) [Reset = 0h]

RGMII_FIFO_STATUS is shown in [Table 8-101](#).

Return to the [Summary Table](#).

Table 8-101. RGMII_FIFO_STATUS Register Field Descriptions

Bit	Field	Type	Reset	Description
15-4	RESERVED	R	0h	Reserved
3	rgmii_rx_af_full_err	R/W0C	0h	RGMII RX fifo full error 0h = No empty fifo error 1h = RGMII TX full error has been indicated
2	rgmii_rx_af_empty_err	R/W0C	0h	RGMII RX fifo empty error 0h = No empty fifo error 1h = RGMII RX empty error has been indicated
1	rgmii_tx_af_full_err	R/W0C	0h	RGMII TX fifo full error 0h = No empty fifo error 1h = RGMII TX full error has been indicated
0	rgmii_tx_af_empty_err	R/W0C	0h	RGMII TX fifo empty error 0h = No empty fifo error 1h = RGMII TX empty error has been indicated

8.6.2.1.79 RGMII_DELAY_CTRL Register (Offset = 602h) [Reset = 0h]

RGMII_DELAY_CTRL is shown in [Table 8-102](#).

Return to the [Summary Table](#).

Table 8-102. RGMII_DELAY_CTRL Register Field Descriptions

Bit	Field	Type	Reset	Description
15-2	RESERVED	R	0h	Reserved
1	rx_clk_sel	R/W	0h	In RGMII mode, Enable or disable the internal delay for RXD wrt RX_CLK (use this mode when RGMII_RX_CLK and RGMII_RXD are aligned). The delay magnitude can be configured by programming register 0x430[7:4] 0h = clock and data are aligned 1h = clock on PIN is delayed by 90 degrees relative to RGMII_RX data
0	tx_clk_sel	R/W	0h	In RGMII mode, Enable or disable the internal delay for TXD wrt TX_CLK (use this mode when RGMII_TX_CLK and RGMII_TXD are aligned). The delay magnitude can be configured by programming register 0x430[11:8] 0h = clock and data are aligned 1h = clock is internally delayed by 90 degrees

8.6.2.1.80 SGMII_CTRL_1 Register (Offset = 608h) [Reset = 7Bh]

SGMII_CTRL_1 is shown in [Table 8-103](#).

Return to the [Summary Table](#).

Table 8-103. SGMII_CTRL_1 Register Field Descriptions

Bit	Field	Type	Reset	Description
15	sgmii_tx_err_dis	R/W	0h	1 = Disable SGMII TX Error indication 0 = Enable SGMII TX Error indication 0h = Enable SGMII TX Error indication 1h = Disable SGMII TX Error indication
14	cfg_align_idx_force	R/W	0h	Force word boundray index selection
13-10	cfg_align_idx_value	R/W	0h	when cfg_align_idx_force = 1 This value set the iword boundray index
9	cfg_sgmii_en	R/W	0h	SGMII enable bit Default from strap 0h = SGMII disable 1h = SGMII enable
8	cfg_sgmii_rx_pol_invert	R/W	0h	SGMII RX bus invert polarity 0h = Polarity not inverted 1h = SGMII RX bus invert polarity
7	cfg_sgmii_tx_pol_invert	R/W	0h	SGMII TX bus invert polarity 0h = Polarity not inverted 1h = SGMII TX bus invert polarity
6-5	serdes_tx_bits_order	R/W	3h	SERDES TX bits order (input to digital core) : 00 - MSB-first in every SERDES data (10 bits) , 1st SERDES data goes to LSB of comma detects 20bits bus (default) 01 - LSB-first in every SERDES data (10 bits) , 1st SERDES data goes to LSB of comma detects 20bits bus 10 - MSB-first in every SERDES data (10 bits) , 1st SERDES data goes to MSB of comma detects 20bits bus 11 - LSB-first in every SERDES data (10 bits) , 1st SERDES data goes to MSB of comma detects 20bits bus 0h = MSB-first in every SERDES data (10 bits) , 1st SERDES data goes to LSB of comma detects 20bits bus (default) 1h = LSB-first in every SERDES data (10 bits) , 1st SERDES data goes to LSB of comma detects 20bits bus 2h = MSB-first in every SERDES data (10 bits) , 1st SERDES data goes to MSB of comma detects 20bits bus 3h = LSB-first in every SERDES data (10 bits) , 1st SERDES data goes to MSB of comma detects 20bits bus
4	serdes_rx_bits_order	R/W	1h	SERDES RX bits order (output of digital core) : 0 - MSB-first 1 - LSB-first (reversed order) 0h = MSB-first 1h = LSB-first (reversed order)

Table 8-103. SGMII_CTRL_1 Register Field Descriptions (continued)

Bit	Field	Type	Reset	Description
3	cfg_align_pkt_en	R/W	1h	For aligning the start of read out TX packet (towards serializer) w/ tx_even pulse. To sync with the Code_Group/OSET FSM code slots. Default is 1, when using 0 we go back to Gemini code
2-1	sgmii_autoneg_timer	R/W	1h	Selects duration of SGMII Auto-Negotiation timer: 00: 1.6ms 01: 2us 10: 800us 11: 11ms 0h = 1.6ms 1h = 2us 2h = 800us 3h = 11ms
0	mr_an_enable	R/W	1h	1 = Enable SGMII Auto-Negotiation 0 = Disable SGMII Auto-Negotiation 0h = Disable SGMII Auto-Negotiation 1h = Enable SGMII Auto-Negotiation

8.6.2.1.81 SGMII_EEE_CTRL_1 Register (Offset = 609h) [Reset = 6318h]

SGMII_EEE_CTRL_1 is shown in [Table 8-104](#).

Return to the [Summary Table](#).

Table 8-104. SGMII_EEE_CTRL_1 Register Field Descriptions

Bit	Field	Type	Reset	Description
15-11	cfg_tx_tr_timer_val	R/W	Ch	
10-6	cfg_tx_tq_timer_val	R/W	Ch	
5-1	cfg_tx_ts_timer_val	R/W	Ch	
0	cfg_support_non_eee_mac_sgmii_en	R/W	0h	special mode to support non sgmii eee mac in eee mode in the phy

8.6.2.1.82 SGMII_STATUS Register (Offset = 60Ah) [Reset = 0h]

SGMII_STATUS is shown in [Table 8-105](#).

Return to the [Summary Table](#).

Table 8-105. SGMII_STATUS Register Field Descriptions

Bit	Field	Type	Reset	Description
15-13	RESERVED	R	0h	Reserved
12	sgmii_page_received	R	0h	Indicates that a new auto neg page was received 0h = No new auto neg page received 1h = A new auto neg page received
11	link_status_1000bx	R	0h	sgmii link status 0h = SGMII link down 1h = SGMII link up
10	mr_an_complete	R	0h	sgmii autoneg complete indication 0h = SGMII autoneg not completed 1h = SGMII autoneg completed
9	cfg_align_en	R	0h	word boundary FSM - align indication
8	cfg_sync_status	R	0h	word boundary FSM - sync status indication 0h = sync not achieved 1h = sync achieved
7-4	cfg_align_idx	R	0h	word boundary index selection
3-0	cfg_state	R	0h	word boundary FSM state

8.6.2.1.83 SGMII_EEE_CTRL_2 Register (Offset = 60Bh) [Reset = 5h]

SGMII_EEE_CTRL_2 is shown in [Table 8-106](#).

Return to the [Summary Table](#).

Table 8-106. SGMII_EEE_CTRL_2 Register Field Descriptions

Bit	Field	Type	Reset	Description
15-4	RESERVED	R	0h	Reserved
3-0	cfg_rx_quiet_timer_val	R/W	5h	

8.6.2.1.84 SGMII_CTRL_2 Register (Offset = 60Ch) [Reset = 1Bh]

SGMII_CTRL_2 is shown in [Table 8-107](#).

Return to the [Summary Table](#).

Table 8-107. SGMII_CTRL_2 Register Field Descriptions

Bit	Field	Type	Reset	Description
15-9	RESERVED	R	0h	Reserved
8	sgmii_signal_detect_force_val	R/W	0h	SGMII cdr lock force value
7	sgmii_signal_detect_force_en	R/W	0h	SGMII cdr lock force enable
6	mr_restart_an	R/WSC,0	0h	Restart sgmii autonegotiation
5-3	tx_half_full_th	R/W	3h	SGMII TX sync FIFO half full threshold
2-0	rx_half_full_th	R/W	3h	SGMII RX sync FIFO half full threshold

8.6.2.1.85 SGMII_FIFO_STATUS Register (Offset = 60Dh) [Reset = 0h]

SGMII_FIFO_STATUS is shown in [Table 8-108](#).

Return to the [Summary Table](#).

Table 8-108. SGMII_FIFO_STATUS Register Field Descriptions

Bit	Field	Type	Reset	Description
15-4	RESERVED	R	0h	Reserved
3	sgmii_rx_af_full_err	R/W0C	0h	SGMII RX fifo full error 0h = No error indication 1h = SGMII RX fifo full error has been indicated
2	sgmii_rx_af_empty_err	R/W0C	0h	SGMII RX fifo empty error 0h = No error indication 1h = SGMII RX fifo empty error has been indicated
1	sgmii_tx_af_full_err	R/W0C	0h	SGMII TX fifo full error 0h = No error indication 1h = SGMII TX fifo full error has been indicated
0	sgmii_tx_af_empty_err	R/W0C	0h	SGMII TX fifo empty error 0h = No error indication 1h = SGMII TX fifo empty error has been indicated

8.6.2.1.86 PRBS_STATUS_1 Register (Offset = 618h) [Reset = 0h]

PRBS_STATUS_1 is shown in [Table 8-109](#).

Return to the [Summary Table](#).

Table 8-109. PRBS_STATUS_1 Register Field Descriptions

Bit	Field	Type	Reset	Description
15-8	RESERVED	R	0h	Reserved
7-0	prbs_err_ov_cnt	R	0h	Holds number of error counter overflow that received by the PRBS checker. Value in this register is locked when write is done to register prbs_status_6 bit[0] or bit[1]. Counter stops on 0xFF. Note: when PRBS counters work in single mode, overflow counter is not active

8.6.2.1.87 PRBS_CTRL_1 Register (Offset = 619h) [Reset = 574h]

PRBS_CTRL_1 is shown in [Table 8-110](#).

Return to the [Summary Table](#).

Table 8-110. PRBS_CTRL_1 Register Field Descriptions

Bit	Field	Type	Reset	Description
15-14	RESERVED	R	0h	Reserved
13	cfg_pkt_gen_64	R/W	0h	Reserved
12	send_pkt	R/WMC,0	0h	Enables generating MAC packet with fix/incremental data w CRC (pkt_gen_en has to be set and cfg_pkt_gen_prbs has to be clear) Cleared automatically when pkt_done is set 0h = Stop MAC packet 1h = Transmit MAC packet w CRC
11	RESERVED	R	0h	Reserved
10-8	cfg_prbs_chk_sel	R/W	5h	000 : Checker receives from RGMII TX 001 : Checker receives SGMII TX 101 : Checker receives from Cu RX 0h = Checker receives from RGMII TX 1h = Checker receives SGMII TX 5h = Checker receives from Cu RX
7	RESERVED	R	0h	Reserved
6-4	cfg_prbs_gen_sel	R/W	7h	000 : PRBS transmits to RGMII RX 001 : PRBS transmits to SGMII RX 101 : PRBS transmits to Cu TX 0h = PRBS transmits to RGMII RX 1h = PRBS transmits to SGMII RX 5h = PRBS transmits to Cu TX
3	cfg_prbs_cnt_mode	R/W	0h	1 = Continuous mode, when one of the PRBS counters reaches max value, pulse is generated and counter starts counting from zero again 0 = Single mode, When one of the PRBS counters reaches max value, PRBS checker stops counting. 0h = Single mode, When one of the PRBS counters reaches max value, PRBS checker stops counting. 1h = Continuous mode, when one of the PRBS counters reaches max value, pulse is generated and counter starts counting from zero again
2	cfg_prbs_chk_enable	R/W	1h	Enable PRBS checker xbar (to receive data) To be enabled for counters in 0x63C, 0x63D, 0x63E to work 0h = Disable PRBS checker 1h = Enable PRBS checker
1	cfg_pkt_gen_prbs	R/W	0h	If set: (1) When pkt_gen_en is set, PRBS packets are generated continuously (3) When pkt_gen_en is cleared, PRBS RX checker is still enabled If cleared: (1) When pkt_gen_en is set, non - PRBS packet is generated (3) When pkt_gen_en is cleared, PRBS RX checker is disabled as well 0h = Stop PRBS packet 1h = Transmit PRBS packet
0	pkt_gen_en	R/W	0h	1 = Enable packet/PRBS generator 0 = Disable packet/PRBS generator 0h = Disable packet/PRBS generator 1h = Enable packet/PRBS generator

8.6.2.1.88 PRBS_CTRL_2 Register (Offset = 61Ah) [Reset = 5DCh]

PRBS_CTRL_2 is shown in [Table 8-111](#).

Return to the [Summary Table](#).

Table 8-111. PRBS_CTRL_2 Register Field Descriptions

Bit	Field	Type	Reset	Description
15-0	cfg_pkt_len_prbs	R/W	5DCh	Length (in bytes) of PRBS packets and MAC packets w CRC

8.6.2.1.89 PRBS_CTRL_3 Register (Offset = 61Bh) [Reset = 7Dh]

PRBS_CTRL_3 is shown in [Table 8-112](#).

Return to the [Summary Table](#).

Table 8-112. PRBS_CTRL_3 Register Field Descriptions

Bit	Field	Type	Reset	Description
15-8	RESERVED	R	0h	Reserved
7-0	cfg_ipg_len	R/W	7Dh	Inter-packet gap (in bytes) between packets

8.6.2.1.90 PRBS_STATUS_2 Register (Offset = 61Ch) [Reset = 0h]

PRBS_STATUS_2 is shown in [Table 8-113](#).

Return to the [Summary Table](#).

Table 8-113. PRBS_STATUS_2 Register Field Descriptions

Bit	Field	Type	Reset	Description
15-0	prbs_byte_cnt	R	0h	Holds number of total bytes that received by the PRBS checker. Value in this register is locked when write is done to register prbs_status_6 bit[0] or bit[1]. When PRBS Count Mode set to zero, count stops on 0xFFFF

8.6.2.1.91 PRBS_STATUS_3 Register (Offset = 61Dh) [Reset = 0h]

PRBS_STATUS_3 is shown in [Table 8-114](#).

Return to the [Summary Table](#).

Table 8-114. PRBS_STATUS_3 Register Field Descriptions

Bit	Field	Type	Reset	Description
15-0	prbs_pkt_cnt_15_0	R	0h	Bits [15:0] of number of total packets received by the PRBS checker. Value in this register is locked when write is done to register prbs_status_6 bit[0] or bit[1]. When PRBS Count Mode set to zero, count stops on 0xFFFFFFFF

8.6.2.1.92 PRBS_STATUS_4 Register (Offset = 61Eh) [Reset = 0h]

PRBS_STATUS_4 is shown in [Table 8-115](#).

Return to the [Summary Table](#).

Table 8-115. PRBS_STATUS_4 Register Field Descriptions

Bit	Field	Type	Reset	Description
15-0	prbs_pkt_cnt_31_16	R	0h	Bits [31:16] of number of total packets received by the PRBS checker Value in this register is locked when write is done to register prbs_status_6 bit[0] or bit[1]. When PRBS Count Mode set to zero, count stops on 0xFFFFFFFF

8.6.2.1.93 PRBS_STATUS_6 Register (Offset = 620h) [Reset = 0h]

PRBS_STATUS_6 is shown in [Table 8-116](#).

Return to the [Summary Table](#).

Table 8-116. PRBS_STATUS_6 Register Field Descriptions

Bit	Field	Type	Reset	Description
15-13	RESERVED	R	0h	Reserved
12	pkt_done	R	0h	Set when all MAC packets w CRC are transmitted 0h = MAC packet transmission in progress 1h = MAC packets transmission completed
11	pkt_gen_busy	R	0h	1 = Packet generator is in process 0 = Packet generator is not in process 0h = Packet generator is not in process 1h = Packet generator is in process
10	prbs_pkt_ov	R	0h	If set, packet counter reached overflow Overflow is cleared when PRBS counters are cleared - done by setting bit #1 of prbs_status_6 0h = No overflow 1h = Packet counter overflow
9	prbs_byte_ov	R	0h	If set, bytes counter reached overflow Overflow is cleared when PRBS counters are cleared - done by setting bit #1 of prbs_status_6 0h = No overflow 1h = byte counter overflow
8	prbs_lock	R	0h	1 = PRBS checker is locked sync) on received byte stream 0 = PRBS checker is not locked 0h = PRBS checker is not locked 1h = PRBS checker is locked sync) on received byte stream
7-0	prbs_err_cnt	R	0h	Holds number of errored bits received by the PRBS checker Value in this register is locked when write is done to bit[0] or bit[1] When PRBS Count Mode set to zero, count stops on 0xFF Notes: Writing bit 0 generates a lock signal for the PRBS counters. Writing bit 1 generates a lock and clear signal for the PRBS counters

8.6.2.1.94 PRBS_STATUS_8 Register (Offset = 622h) [Reset = 0h]

PRBS_STATUS_8 is shown in [Table 8-117](#).

Return to the [Summary Table](#).

Table 8-117. PRBS_STATUS_8 Register Field Descriptions

Bit	Field	Type	Reset	Description
15-0	pkt_err_cnt_15_0	R	0h	Bits [15:0] of number of total packets with error received by the PRBS checker Value in this register is locked when write is done to register prbs_status_6 bit[0] or bit[1]. When PRBS Count Mode set to zero, count stops on 0xFFFFFFFF

8.6.2.1.95 PRBS_STATUS_9 Register (Offset = 623h) [Reset = 0h]

PRBS_STATUS_9 is shown in [Table 8-118](#).

Return to the [Summary Table](#).

Table 8-118. PRBS_STATUS_9 Register Field Descriptions

Bit	Field	Type	Reset	Description
15-0	pkt_err_cnt_31_16	R	0h	Bits [31:16] of number of total packets with error received by the PRBS checker Value in this register is locked when write is done to register prbs_status_6 bit[0] or bit[1]. When PRBS Count Mode set to zero, count stops on 0xFFFFFFFF

8.6.2.1.96 PRBS_CTRL_4 Register (Offset = 624h) [Reset = 5511h]

PRBS_CTRL_4 is shown in [Table 8-119](#).

Return to the [Summary Table](#).

Table 8-119. PRBS_CTRL_4 Register Field Descriptions

Bit	Field	Type	Reset	Description
15-8	cfg_pkt_data	R/W	55h	Fixed data to be sent in Fix data mode
7-6	cfg_pkt_mode	R/W	0h	2b00 - Incremental 2b01 - Fixed 2b1x - PRBS 0h = Incremental 1h = Fixed
5-3	cfg_pattern_vld_bytes	R/W	2h	Number of bytes of valid pattern in packet (Max - 6) 0h = 0 bytes 1h = 1 bytes 2h = 2 bytes 3h = 3 bytes 4h = 4 bytes 5h = 5 bytes 6h = 6 bytes 7h = 6 bytes
2-0	cfg_pkt_cnt	R/W	1h	000b = 1 packet 001b = 10 packets 010b = 100 packets 011b = 1000 packets 100b = 10000 packets 101b = 100000 packets 110b = 1000000 packets 111b = Continuous packets 0h = 1 packet 1h = 10 packets 2h = 100 packets 3h = 1000 packets 4h = 10000 packets 5h = 100000 packets 6h = 1000000 packets 7h = Continuous packets

8.6.2.1.97 PRBS_CTRL_5 Register (Offset = 625h) [Reset = 0h]

PRBS_CTRL_5 is shown in [Table 8-120](#).

Return to the [Summary Table](#).

Table 8-120. PRBS_CTRL_5 Register Field Descriptions

Bit	Field	Type	Reset	Description
15-0	pattern_15_0	R/W	0h	Bits 15:0 of pattern

8.6.2.1.98 PRBS_CTRL_6 Register (Offset = 626h) [Reset = 0h]

PRBS_CTRL_6 is shown in [Table 8-121](#).

Return to the [Summary Table](#).

Table 8-121. PRBS_CTRL_6 Register Field Descriptions

Bit	Field	Type	Reset	Description
15-0	pattern_31_16	R/W	0h	Bits 31:16 of pattern

8.6.2.1.99 PRBS_CTRL_7 Register (Offset = 627h) [Reset = 0h]

 PRBS_CTRL_7 is shown in [Table 8-122](#).

 Return to the [Summary Table](#).

Table 8-122. PRBS_CTRL_7 Register Field Descriptions

Bit	Field	Type	Reset	Description
15-0	pattern_47_32	R/W	0h	Bits 47:32 of pattern

8.6.2.1.100 PRBS_CTRL_8 Register (Offset = 628h) [Reset = 0h]

 PRBS_CTRL_8 is shown in [Table 8-123](#).

 Return to the [Summary Table](#).

Table 8-123. PRBS_CTRL_8 Register Field Descriptions

Bit	Field	Type	Reset	Description
15-0	pmatch_data_15_0	R/W	0h	Bits 15:0 of Perfect Match Data - used for DA (destination address) match

8.6.2.1.101 PRBS_CTRL_9 Register (Offset = 629h) [Reset = 0h]

 PRBS_CTRL_9 is shown in [Table 8-124](#).

 Return to the [Summary Table](#).

Table 8-124. PRBS_CTRL_9 Register Field Descriptions

Bit	Field	Type	Reset	Description
15-0	pmatch_data_31_16	R/W	0h	Bits 31:16 of Perfect Match Data - used for DA (destination address) match

8.6.2.1.102 PRBS_CTRL_10 Register (Offset = 62Ah) [Reset = 0h]

 PRBS_CTRL_10 is shown in [Table 8-125](#).

 Return to the [Summary Table](#).

Table 8-125. PRBS_CTRL_10 Register Field Descriptions

Bit	Field	Type	Reset	Description
15-0	pmatch_data_47_32	R/W	0h	Bits 47:32 of Perfect Match Data - used for DA (destination address) match

8.6.2.1.103 CRC_STATUS Register (Offset = 638h) [Reset = 0h]

 CRC_STATUS is shown in [Table 8-126](#).

 Return to the [Summary Table](#).

Table 8-126. CRC_STATUS Register Field Descriptions

Bit	Field	Type	Reset	Description
15-2	RESERVED	R	0h	Reserved
1	rx_bad_crc	R	0h	CRC error indication in packet received on Cu RX 0h = No CRC error 1h = CRC error

Table 8-126. CRC_STATUS Register Field Descriptions (continued)

Bit	Field	Type	Reset	Description
0	tx_bad_crc	R	0h	CRC error indication in packet transmitted on Cu TX 0h = No CRC error 1h = CRC error

8.6.2.1.104 PKT_STAT_1 Register (Offset = 639h) [Reset = 0h]

PKT_STAT_1 is shown in [Table 8-127](#).

Return to the [Summary Table](#).

Table 8-127. PKT_STAT_1 Register Field Descriptions

Bit	Field	Type	Reset	Description
15-0	tx_pkt_cnt_15_0		0h	Lower 16 bits of Tx packet counter Note : Register is cleared when 0x39, 0x3A, 0x3B are read in sequence

8.6.2.1.105 PKT_STAT_2 Register (Offset = 63Ah) [Reset = 0h]

PKT_STAT_2 is shown in [Table 8-128](#).

Return to the [Summary Table](#).

Table 8-128. PKT_STAT_2 Register Field Descriptions

Bit	Field	Type	Reset	Description
15-0	tx_pkt_cnt_31_16		0h	Upper 16 bits of Tx packet counter Note : Register is cleared when 0x39, 0x3A, 0x3B are read in sequence

8.6.2.1.106 PKT_STAT_3 Register (Offset = 63Bh) [Reset = 0h]

PKT_STAT_3 is shown in [Table 8-129](#).

Return to the [Summary Table](#).

Table 8-129. PKT_STAT_3 Register Field Descriptions

Bit	Field	Type	Reset	Description
15-0	tx_err_pkt_cnt		0h	Tx packet w error (CRC error) counter Note : Register is cleared when 0x39, 0x3A, 0x3B are read in sequence

8.6.2.1.107 PKT_STAT_4 Register (Offset = 63Ch) [Reset = 0h]

PKT_STAT_4 is shown in [Table 8-130](#).

Return to the [Summary Table](#).

Table 8-130. PKT_STAT_4 Register Field Descriptions

Bit	Field	Type	Reset	Description
15-0	rx_pkt_cnt_15_0		0h	Lower 16 bits of Rx packet counter Note : Register is cleared when 0x3C, 0x3D, 0x3E are read in sequence

8.6.2.1.108 PKT_STAT_5 Register (Offset = 63Dh) [Reset = 0h]

PKT_STAT_5 is shown in [Table 8-131](#).

Return to the [Summary Table](#).

Table 8-131. PKT_STAT_5 Register Field Descriptions

Bit	Field	Type	Reset	Description
15-0	rx_pkt_cnt_31_16		0h	Upper 16 bits of Rx packet counter Note : Register is cleared when 0x3C, 0x3D, 0x3E are read in sequence

8.6.2.1.109 PKT_STAT_6 Register (Offset = 63Eh) [Reset = 0h]

PKT_STAT_6 is shown in [Table 8-132](#).

Return to the [Summary Table](#).

Table 8-132. PKT_STAT_6 Register Field Descriptions

Bit	Field	Type	Reset	Description
15-0	rx_err_pkt_cnt		0h	Rx packet w error (CRC error) counter Note : Register is cleared when 0x3C, 0x3D, 0x3E are read in sequence

8.6.2.1.110 DSP_REG_0 Register (Offset = 800h) [Reset = 0h]

DSP_REG_0 is shown in [Table 8-133](#).

Return to the [Summary Table](#).

Table 8-133. DSP_REG_0 Register Field Descriptions

Bit	Field	Type	Reset	Description
15	RESERVED	R	0h	Reserved
14	RESERVED	R	0h	Reserved
13	RESERVED	R	0h	Reserved
12	RESERVED	R	0h	Reserved
11	cfg_deq_bypass	R/W	0h	
10	RESERVED	R	0h	Reserved
9	RESERVED	R	0h	Reserved
8	RESERVED	R	0h	Reserved
7	RESERVED	R	0h	Reserved
6	RESERVED	R	0h	Reserved
5	RESERVED	R	0h	Reserved
4	RESERVED	R	0h	Reserved
3	RESERVED	R	0h	Reserved
2	RESERVED	R	0h	Reserved
1	RESERVED	R	0h	Reserved
0	RESERVED	R	0h	Reserved

8.6.2.1.111 SQI_REG_1 Register (Offset = 871h) [Reset = 0h]

SQI_REG_1 is shown in [Table 8-134](#).

Return to the [Summary Table](#).

Table 8-134. SQI_REG_1 Register Field Descriptions

Bit	Field	Type	Reset	Description
7-5	worst_sqi_out		0h	3 bit Worst SQI since last read (see SQI mapping above)
4	RESERVED	R	0h	Reserved

Table 8-134. SQI_REG_1 Register Field Descriptions (continued)

Bit	Field	Type	Reset	Description
3-1	sqi_out	R	0h	3 bit SQI - (mse here refers to Mean Square Error 0x875[9:0]) 0b000 = MSE > 102 0b001 = 81 < MSE ≤ 102 0b010 = 65 < MSE ≤ 81 0b011 = 51 < MSE ≤ 65 0b100 = 41 < MSE ≤ 51 0b101 = 32 < MSE ≤ 41 0b110 = 25 < MSE ≤ 32 0b111 = MSE ≤ 25
0	RESERVED	R	0h	Reserved

8.6.2.1.112 SQI_1 Register (Offset = 8ADh) [Reset = 3051h]

SQI_1 is shown in [Table 8-135](#).

Return to the [Summary Table](#).

Table 8-135. SQI_1 Register Field Descriptions

Bit	Field	Type	Reset	Description
15-12	cfg_hist_1_2	R/W	3h	Hysteresis between SQI value 1 and 2
11-10	cfg_acc_window_sel	R/W	0h	Accumulator window select - 00b = 90us 01b = 180us 10b = 360us 11b = 720us
9-0	cfg_sqi_th_1_2	R/W	51h	Threshold between SQI value 1 and 2

8.6.2.1.113 SQI_2 Register (Offset = 8EDh) [Reset = 3041h]

SQI_2 is shown in [Table 8-136](#).

Return to the [Summary Table](#).

Table 8-136. SQI_2 Register Field Descriptions

Bit	Field	Type	Reset	Description
15-12	cfg_hist_2_3	R/W	3h	Hysteresis between SQI value 2 and 3
11-10	RESERVED	R	0h	Reserved
9-0	cfg_sqi_th_2_3	R/W	41h	Threshold between SQI value 2 and 3

8.6.2.1.114 SQI_3 Register (Offset = 8EFh) [Reset = 3033h]

SQI_3 is shown in [Table 8-137](#).

Return to the [Summary Table](#).

Table 8-137. SQI_3 Register Field Descriptions

Bit	Field	Type	Reset	Description
15-12	cfg_hist_3_4	R/W	3h	Hysteresis between SQI value 3 and 4
11-10	RESERVED	R	0h	Reserved
9-0	cfg_sqi_th_3_4	R/W	33h	Threshold between SQI value 3 and 4

8.6.2.1.115 SQI_4 Register (Offset = 8F0h) [Reset = 3029h]

SQI_4 is shown in [Table 8-138](#).

Return to the [Summary Table](#).

Table 8-138. SQI_4 Register Field Descriptions

Bit	Field	Type	Reset	Description
15-12	cfg_hist_4_5	R/W	3h	Hysteresis between SQI value 4 and 5
11-10	RESERVED	R	0h	Reserved

Table 8-138. SQI_4 Register Field Descriptions (continued)

Bit	Field	Type	Reset	Description
9-0	cfg_sqi_th_4_5	R/W	29h	Threshold between SQI value 4 and 5

8.6.2.1.116 SQI_5 Register (Offset = 8F1h) [Reset = 2020h]

SQI_5 is shown in [Table 8-139](#).

Return to the [Summary Table](#).

Table 8-139. SQI_5 Register Field Descriptions

Bit	Field	Type	Reset	Description
15-12	cfg_hist_5_6	R/W	2h	Hysteresis between SQI value 5 and 6
11-10	RESERVED	R	0h	Reserved
9-0	cfg_sqi_th_5_6	R/W	20h	Threshold between SQI value 5 and 6

8.6.2.1.117 SQI_6 Register (Offset = 8F2h) [Reset = 2019h]

SQI_6 is shown in [Table 8-140](#).

Return to the [Summary Table](#).

Table 8-140. SQI_6 Register Field Descriptions

Bit	Field	Type	Reset	Description
15-12	cfg_hist_6_7	R/W	2h	Hysteresis between SQI value 6 and 7
11-10	RESERVED	R	0h	Reserved
9-0	cfg_sqi_th_6_7	R/W	19h	Threshold between SQI value 6 and 7

8.6.2.1.118 PMA_PMD_CONTROL_1 Register (Offset = 1000h) [Reset = 0h]

PMA_PMD_CONTROL_1 is shown in [Table 8-141](#).

Return to the [Summary Table](#).

First nibble (0x1) in the register address is to indicated MMD register space. For register access, ignore the first nibble.

Table 8-141. PMA_PMD_CONTROL_1 Register Field Descriptions

Bit	Field	Type	Reset	Description
15	pma_reset_2	R	0h	1 = PMA/PMD reset 0 = Normal operation Note - RW bit, self clearing Note - 0x1 added in [15:12] to differentiate 0h = Normal operation 1h = PMA/PMD reset
14-12	RESERVED	R	0h	Reserved
11	cfg_low_power_2	R	0h	1 = Low-power mode 0 = Normal operation Note - RW bit Note - 0x1 added in [15:12] to differentiate 0h = Normal operation 1h = Low-power mode
10-0	RESERVED	R	0h	Reserved

8.6.2.1.119 PMA_PMD_CONTROL_2 Register (Offset = 1007h) [Reset = 3Dh]

PMA_PMD_CONTROL_2 is shown in [Table 8-142](#).

Return to the [Summary Table](#).

First nibble (0x1) in the register address is to indicated MMD register space. For register access, ignore the first nibble.

Table 8-142. PMA_PMD_CONTROL_2 Register Field Descriptions

Bit	Field	Type	Reset	Description
15-6	RESERVED	R	0h	Reserved
5-0	cfg_pma_type_selection	R/W	3Dh	BASE-T1 type selection for device Note - 0x1 added in [15:12] to differentiate 3Dh = BASE-T1 type selection for device

8.6.2.1.120 PMA_PMD_TRANSMIT_DISABLE Register (Offset = 1009h) [Reset = 0h]

PMA_PMD_TRANSMIT_DISABLE is shown in [Table 8-143](#).

Return to the [Summary Table](#).

First nibble (0x1) in the register address is to indicated MMD register space. For register access, ignore the first nibble.

Table 8-143. PMA_PMD_TRANSMIT_DISABLE Register Field Descriptions

Bit	Field	Type	Reset	Description
15-1	RESERVED	R	0h	Reserved
0	cfg_transmit_disable_2	R	0h	1 = Transmit disable 0 = Normal operation Note - RW bit Note - 0x1 added in [15:12] to differentiate 0h = Normal operation 1h = Transmit disable

8.6.2.1.121 PMA_PMD_EXTENDED_ABILITY2 Register (Offset = 100Bh) [Reset = 800h]

PMA_PMD_EXTENDED_ABILITY2 is shown in [Table 8-144](#).

Return to the [Summary Table](#).

First nibble (0x1) in the register address is to indicated MMD register space. For register access, ignore the first nibble.

Table 8-144. PMA_PMD_EXTENDED_ABILITY2 Register Field Descriptions

Bit	Field	Type	Reset	Description
15-12	RESERVED	R	0h	Reserved
11	base_t1_extended_abilities	R	1h	1 = PMA/PMD has BASE-T1 extended abilities listed in register 1.18 0 = PMA/PMD does not have BASE-T1 extended abilities Note - 0x1 added in [15:12] to differentiate 0h = PMA/PMD does not have BASE-T1 extended abilities 1h = PMA/PMD has BASE-T1 extended abilities listed in register 1.18
10-0	RESERVED	R	0h	Reserved

8.6.2.1.122 PMA_PMD_EXTENDED_ABILITY Register (Offset = 1012h) [Reset = 2h]

PMA_PMD_EXTENDED_ABILITY is shown in [Table 8-145](#).

Return to the [Summary Table](#).

First nibble (0x1) in the register address is to indicated MMD register space. For register access, ignore the first nibble.

Table 8-145. PMA_PMD_EXTENDED_ABILITY Register Field Descriptions

Bit	Field	Type	Reset	Description
15-2	RESERVED	R	0h	Reserved

Table 8-145. PMA_PMD_EXTENDED_ABILITY Register Field Descriptions (continued)

Bit	Field	Type	Reset	Description
1	mr_1000_base_t1_ability	R	1h	1 = PMA/PMD is able to perform 1000BASE-T1 0 = PMA/PMD is not able to perform 1000BASE-T1 Note - 0x1 added in [15:12] to differentiate 0h = PMA/PMD is not able to perform 1000BASE-T1 1h = PMA/PMD is able to perform 1000BASE-T1
0	mr_100_base_t1_ability	R	0h	1 = PMA/PMD is able to perform 100BASE-T1 0 = PMA/PMD is not able to perform 100BASE-T1 Note - 0x1 added in [15:12] to differentiate 0h = PMA/PMD is not able to perform 100BASE-T1 1h = PMA/PMD is able to perform 100BASE-T1

8.6.2.1.123 PMA_PMD_CONTROL Register (Offset = 1834h) [Reset = 8000h]

PMA_PMD_CONTROL is shown in [Table 8-146](#).

Return to the [Summary Table](#).

First nibble (0x1) in the register address is to indicated MMD register space. For register access, ignore the first nibble.

Table 8-146. PMA_PMD_CONTROL Register Field Descriptions

Bit	Field	Type	Reset	Description
15	RESERVED	R	1h	Reserved
14	cfg_master_slave_val	R/W	0h	1 = Configure PHY as MASTER 0 = Configure PHY as SLAVE Note - 0x1 added in [15:12] to differentiate 0h = Configure PHY as SLAVE 1h = Configure PHY as MASTER
13-4	RESERVED	R	0h	Reserved
3-0	RESERVED	R	0h	Reserved

8.6.2.1.124 PMA_CONTROL Register (Offset = 1900h) [Reset = 0h]

PMA_CONTROL is shown in [Table 8-147](#).

Return to the [Summary Table](#).

First nibble (0x1) in the register address is to indicated MMD register space. For register access, ignore the first nibble.

Table 8-147. PMA_CONTROL Register Field Descriptions

Bit	Field	Type	Reset	Description
15	pma_reset	R	0h	1 = PMA/PMD reset 0 = Normal operation Note - RW bit, self clearing Note - 0x1 added in [15:12] to differentiate 0h = Normal operation 1h = PMA/PMD reset
14	cfg_transmit_disable	R	0h	1 = Transmit disable 0 = Normal operation Note - RW bit Note - 0x1 added in [15:12] to differentiate 0h = Normal operation 1h = Transmit disable
13-12	RESERVED	R	0h	Reserved
11	cfg_low_power	R	0h	1 = Low-power mode 0 = Normal operation Note - RW bit Note - 0x1 added in [15:12] to differentiate 0h = Normal operation 1h = Low-power mode
10-0	RESERVED	R	0h	Reserved

8.6.2.1.125 PMA_STATUS Register (Offset = 1901h) [Reset = 900h]

PMA_STATUS is shown in [Table 8-148](#).

Return to the [Summary Table](#).

First nibble (0x1) in the register address is to indicated MMD register space. For register access, ignore the first nibble.

Table 8-148. PMA_STATUS Register Field Descriptions

Bit	Field	Type	Reset	Description
15-12	RESERVED	R	0h	Reserved
11	oam_ability	R	1h	1 = PHY has 1000BASE-T1 OAM ability 0 = PHY does not have 1000BASE-T1 OAM ability Note - 0x1 added in [15:12] to differentiate 0h = PHY does not have 1000BASE-T1 OAM ability 1h = PHY has 1000BASE-T1 OAM ability
10	eee_ability	R	0h	1 = PHY has EEE ability 0 = PHY does not have EEE ability Note - 0x1 added in [15:12] to differentiate 0h = PHY does not have EEE ability 1h = PHY has EEE ability
9	receive_fault_ability	R	0h	1 = PMA/PMD has the ability to detect a fault condition on the receive path 0 = PMA/PMD does not have the ability to detect a fault condition on the receive path Note - 0x1 added in [15:12] to differentiate 0h = PMA/PMD does not have the ability to detect a fault condition on the receive path 1h = PMA/PMD has the ability to detect a fault condition on the receive path
8	low_power_ability	R	1h	1 = PMA/PMD has low-power ability 0 = PMA/PMD does not have low-power ability Note - 0x1 added in [15:12] to differentiate 0h = PMA/PMD does not have low-power ability 1h = PMA/PMD has low-power ability
7-3	RESERVED	R	0h	Reserved
2	receive_polarity	R	0h	1 = Receive polarity is reversed 0 = Receive polarity is not reversed Note - 0x1 added in [15:12] to differentiate 0h = Receive polarity is not reversed 1h = Receive polarity is reversed
1	receive_fault	R	0h	1 = Fault condition detected 0 = Fault condition not detected Note - 0x1 added in [15:12] to differentiate 0h = Fault condition not detected 1h = Fault condition detected
0	pma_receive_link_status_1	R/W0S	0h	1 = PMA/PMD receive link up 0 = PMA/PMD receive link down Note - 0x1 added in [15:12] to differentiate 0h = PMA/PMD receive link down 1h = PMA/PMD receive link up

8.6.2.1.126 TRAINING Register (Offset = 1902h) [Reset = 2h]

TRAINING is shown in [Table 8-149](#).

Return to the [Summary Table](#).

First nibble (0x1) in the register address is to indicated MMD register space. For register access, ignore the first nibble.

Table 8-149. TRAINING Register Field Descriptions

Bit	Field	Type	Reset	Description
15-11	RESERVED	R	0h	Reserved
10-4	cfg_training_user fld	R/W	0h	7-bit user defined field to send to the link partner Note - 0x1 added in [15:12] to differentiate

Table 8-149. TRAINING Register Field Descriptions (continued)

Bit	Field	Type	Reset	Description
3-2	RESERVED	R	0h	Reserved
1	cfg_oam_en	R/W	1h	1 = 1000BASE-T1 OAM ability advertised to link partner 0 = 1000BASE-T1 OAM ability not advertised to link partner Note - 0x1 added in [15:12] to differentiate 0h = 1000BASE-T1 OAM ability not advertised to link partner 1h = 1000BASE-T1 OAM ability advertised to link partner
0	cfg_eee_en	R/W	0h	1 = EEE ability advertised to link partner 0 = EEE ability not advertised to link partner Note - 0x1 added in [15:12] to differentiate 0h = EEE ability not advertised to link partner 1h = EEE ability advertised to link partner

8.6.2.1.127 LP_TRAINING Register (Offset = 1903h) [Reset = 0h]

LP_TRAINING is shown in [Table 8-150](#).

Return to the [Summary Table](#).

First nibble (0x1) in the register address is to indicated MMD register space. For register access, ignore the first nibble.

Table 8-150. LP_TRAINING Register Field Descriptions

Bit	Field	Type	Reset	Description
15-11	RESERVED	R	0h	Reserved
10-4	lp_training_user_fid	R	0h	7-bit user defined field received from the link partner Note - 0x1 added in [15:12] to differentiate
3-2	RESERVED	R	0h	Reserved
1	lp_oam_adv	R	0h	1 = Link partner has 1000BASE-T1 OAM ability 0 = Link partner does not have 1000BASE-T1 OAM ability Note - 0x1 added in [15:12] to differentiate 0h = Link partner does not have 1000BASE-T1 OAM ability 1h = Link partner has 1000BASE-T1 OAM ability
0	lp_eee_adv	R	0h	1 = Link partner has EEE ability 0 = Link partner does not have EEE ability Note - 0x1 added in [15:12] to differentiate 0h = Link partner does not have EEE ability 1h = Link partner has EEE ability

8.6.2.1.128 TEST_MODE_CONTROL Register (Offset = 1904h) [Reset = 0h]

TEST_MODE_CONTROL is shown in [Table 8-151](#).

Return to the [Summary Table](#).

First nibble (0x1) in the register address is to indicated MMD register space. For register access, ignore the first nibble.

Table 8-151. TEST_MODE_CONTROL Register Field Descriptions

Bit	Field	Type	Reset	Description
15-13	cfg_test_mode	R/W	0h	111b = Test mode 7 110b = Test mode 6 101b = Test mode 5 100b = Test mode 4 011b = Reserved 010b = Test mode 2 001b = Test mode 1 000b = Normal (non-test) operation Note - 0x1 added in [15:12] to differentiate 0h = Normal (non-test) operation 1h = Test mode 1 2h = Test mode 2 3h = Reserved 4h = Test mode 4 5h = Test mode 5 6h = Test mode 6 7h = Test mode 7
12-0	RESERVED	R	0h	Reserved

8.6.2.1.129 PCS_CONTROL_COPY Register (Offset = 3000h) [Reset = 0h]

PCS_CONTROL_COPY is shown in [Table 8-152](#).

Return to the [Summary Table](#).

First nibble (0x3) in the register address is to indicated MMD register space. For register access, ignore the first nibble.

Table 8-152. PCS_CONTROL_COPY Register Field Descriptions

Bit	Field	Type	Reset	Description
15	pcs_reset_2	R	0h	1 = PCS reset 0 = Normal operation Note - RW bit, self clear bit Note - 0x3 added in [15:12] to differentiate 0h = Normal operation 1h = PCS reset
14	mmd3_loopback_2	R	0h	1 = Enable loopback mode 0 = Disable loopback mode Note - RW bit Note - 0x3 added in [15:12] to differentiate 0h = Disable loopback mode 1h = Enable loopback mode
13-0	RESERVED	R	0h	Reserved

8.6.2.1.130 PCS_CONTROL Register (Offset = 3900h) [Reset = 0h]

PCS_CONTROL is shown in [Table 8-153](#).

Return to the [Summary Table](#).

First nibble (0x3) in the register address is to indicated MMD register space. For register access, ignore the first nibble.

Table 8-153. PCS_CONTROL Register Field Descriptions

Bit	Field	Type	Reset	Description
15	pcs_reset	R	0h	1 = PCS reset 0 = Normal operation Note - RW bit, self clear bit Note - 0x3 added in [15:12] to differentiate 0h = Normal operation 1h = PCS reset
14	mmd3_loopback	R	0h	1 = Enable loopback mode 0 = Disable loopback mode Note - RW bit Note - 0x3 added in [15:12] to differentiate 0h = Disable loopback mode 1h = Enable loopback mode
13-0	RESERVED	R	0h	Reserved

8.6.2.1.131 PCS_STATUS Register (Offset = 3901h) [Reset = 0h]

PCS_STATUS is shown in [Table 8-154](#).

Return to the [Summary Table](#).

First nibble (0x3) in the register address is to indicated MMD register space. For register access, ignore the first nibble.

Table 8-154. PCS_STATUS Register Field Descriptions

Bit	Field	Type	Reset	Description
15-12	RESERVED	R	0h	Reserved
11	tx_lpi_received_lh	R/W0C	0h	1 = Tx PCS has received LPI 0 = LPI not received Note - 0x3 added in [15:12] to differentiate 0h = LPI not received 1h = Tx PCS has received LPI
10	rx_lpi_received_lh	R/W0C	0h	1 = Rx PCS has received LPI 0 = LPI not received Note - 0x3 added in [15:12] to differentiate 0h = LPI not received 1h = Rx PCS has received LPI
9	tx_lpi_indication	R	0h	1 = Tx PCS is currently receiving LPI 0 = PCS is not currently receiving LPI Note - 0x3 added in [15:12] to differentiate 0h = PCS is not currently receiving LPI 1h = Tx PCS is currently receiving LPI
8	rx_lpi_indication	R	0h	1 = Rx PCS is currently receiving LPI 0 = PCS is not currently receiving LPI Note - 0x3 added in [15:12] to differentiate 0h = PCS is not currently receiving LPI 1h = Rx PCS is currently receiving LPI
7	pcs_fault	R	0h	1 = Fault condition detected 0 = No fault condition detected Note - 0x3 added in [15:12] to differentiate 0h = No fault condition detected 1h = Fault condition detected
6-3	RESERVED	R	0h	Reserved
2	pcs_receive_link_status_ll	R/W0S	0h	1 = PCS receive link up 0 = PCS receive link down Note - 0x3 added in [15:12] to differentiate 0h = PCS receive link down 1h = PCS receive link up
1-0	RESERVED	R	0h	Reserved

8.6.2.1.132 PCS_STATUS_2 Register (Offset = 3902h) [Reset = 0h]

PCS_STATUS_2 is shown in [Table 8-155](#).

Return to the [Summary Table](#).

First nibble (0x3) in the register address is to indicated MMD register space. For register access, ignore the first nibble.

Table 8-155. PCS_STATUS_2 Register Field Descriptions

Bit	Field	Type	Reset	Description
15-11	RESERVED	R	0h	Reserved
10	pcs_receive_link_status	R	0h	1 = PCS receive link up 0 = PCS receive link down Note - 0x3 added in [15:12] to differentiate 0h = PCS receive link down 1h = PCS receive link up
9	hi_rfer	R	0h	1 = PCS reporting a high BER 0 = PCS not reporting a high BER Note - 0x3 added in [15:12] to differentiate 0h = PCS not reporting a high BER 1h = PCS reporting a high BER

Table 8-155. PCS_STATUS_2 Register Field Descriptions (continued)

Bit	Field	Type	Reset	Description
8	block_lock	R	0h	1 = PCS locked to received blocks 0 = PCS not locked to received blocks Note - 0x3 added in [15:12] to differentiate 0h = PCS not locked to received blocks 1h = PCS locked to received blocks
7	hi_rfer_lh	R/W0C	0h	1 = PCS has reported a high BER 0 = PCS has not reported a high BER Note - 0x3 added in [15:12] to differentiate 0h = PCS has not reported a high BER 1h = PCS has reported a high BER
6	block_lock_ll	R/W0S	0h	1 = PCS has block lock 0 = PCS does not have block lock Note - 0x3 added in [15:12] to differentiate 0h = PCS does not have block lock 1h = PCS has block lock
5-0	ber_count		0h	BER counter Note - 0x3 added in [15:12] to differentiate

8.6.2.1.133 OAM_TRANSMIT Register (Offset = 3904h) [Reset = 0h]

OAM_TRANSMIT is shown in [Table 8-156](#).

Return to the [Summary Table](#).

First nibble (0x3) in the register address is to indicated MMD register space. For register access, ignore the first nibble.

Table 8-156. OAM_TRANSMIT Register Field Descriptions

Bit	Field	Type	Reset	Description
15	mr_tx_valid	R/WMC,0	0h	This bit is used to indicate message data in registers 3.2308.11:8, 3.2309, 3.2310, 3.2311, and 3.2312 are valid and ready to be loaded. This bit shall self-clear when registers are loaded by the state machine. 1 = Message data in registers are valid 0 = Message data in registers are not valid Note - 0x3 added in [15:12] to differentiate 0h = Message data in registers are not valid 1h = Message data in registers are valid
14	mr_tx_toggle	R	0h	Toggle value to be transmitted with message. This bit is set by the state machine and cannot be overridden by the user. Note - 0x3 added in [15:12] to differentiate
13	mr_tx_received		0h	This bit shall self clear on read. 1 = 1000BASE-T1 OAM message received by link partner 0 = 1000BASE-T1 OAM message not received by link partner Note - 0x3 added in [15:12] to differentiate 0h = 1000BASE-T1 OAM message not received by link partner 1h = 1000BASE-T1 OAM message received by link partner
12	mr_tx_received_toggle	R	0h	Toggle value of message that was received by link partner Note - 0x3 added in [15:12] to differentiate
11-8	mr_tx_message_num	R/W	0h	User-defined message number to send Note - 0x3 added in [15:12] to differentiate
7-4	RESERVED	R	0h	Reserved
3	mr_rx_ping	R	0h	Received PingTx value from latest good 1000BASE-T1 OAM frame received Note - 0x3 added in [15:12] to differentiate
2	mr_tx_ping	R/W	0h	Ping value to send to link partner Note - 0x3 added in [15:12] to differentiate

Table 8-156. OAM_TRANSMIT Register Field Descriptions (continued)

Bit	Field	Type	Reset	Description
1-0	mr_tx_snr	R	0h	00 = PHY link is failing and will drop link and relink within 2 ms to 4 ms after the end of the current 1000BASE-T1 OAM frame. 01 = LPI refresh is insufficient to maintain PHY SNR. Request link partner to exit LPI and send idles (used only when EEE is enabled). 10 = PHY SNR is marginal. 11 = PHY SNR is good. Note - 0x3 added in [15:12] to differentiate 0h = PHY link is failing and will drop link and relink within 2 ms to 4 ms after the end of the current 1000BASE-T1 OAM frame. 1h = LPI refresh is insufficient to maintain PHY SNR. Request link partner to exit LPI and send idles (used only when EEE is enabled). 2h = PHY SNR is marginal. 3h = PHY SNR is good.

8.6.2.1.134 OAM_TX_MESSAGE_1 Register (Offset = 3905h) [Reset = 0h]

OAM_TX_MESSAGE_1 is shown in [Table 8-157](#).

Return to the [Summary Table](#).

First nibble (0x3) in the register address is to indicated MMD register space. For register access, ignore the first nibble.

Table 8-157. OAM_TX_MESSAGE_1 Register Field Descriptions

Bit	Field	Type	Reset	Description
15-0	mr_tx_message_15_0	R/W	0h	Message octet 1/0. LSB transmitted first. Note - 0x3 added in [15:12] to differentiate

8.6.2.1.135 OAM_TX_MESSAGE_2 Register (Offset = 3906h) [Reset = 0h]

OAM_TX_MESSAGE_2 is shown in [Table 8-158](#).

Return to the [Summary Table](#).

First nibble (0x3) in the register address is to indicated MMD register space. For register access, ignore the first nibble.

Table 8-158. OAM_TX_MESSAGE_2 Register Field Descriptions

Bit	Field	Type	Reset	Description
15-0	mr_tx_message_31_16	R/W	0h	Message octet 3/2. LSB transmitted first. Note - 0x3 added in [15:12] to differentiate

8.6.2.1.136 OAM_TX_MESSAGE_3 Register (Offset = 3907h) [Reset = 0h]

OAM_TX_MESSAGE_3 is shown in [Table 8-159](#).

Return to the [Summary Table](#).

First nibble (0x3) in the register address is to indicated MMD register space. For register access, ignore the first nibble.

Table 8-159. OAM_TX_MESSAGE_3 Register Field Descriptions

Bit	Field	Type	Reset	Description
15-0	mr_tx_message_47_32	R/W	0h	Message octet 5/4. LSB transmitted first. Note - 0x3 added in [15:12] to differentiate

8.6.2.1.137 OAM_TX_MESSAGE_4 Register (Offset = 3908h) [Reset = 0h]

OAM_TX_MESSAGE_4 is shown in [Table 8-160](#).

Return to the [Summary Table](#).

First nibble (0x3) in the register address is to indicated MMD register space. For register access, ignore the first nibble.

Table 8-160. OAM_TX_MESSAGE_4 Register Field Descriptions

Bit	Field	Type	Reset	Description
15-0	mr_tx_message_63_48	R/W	0h	Message octet 7/6. LSB transmitted first. Note - 0x3 added in [15:12] to differentiate

8.6.2.1.138 OAM_RECEIVE Register (Offset = 3909h) [Reset = 0h]

OAM_RECEIVE is shown in [Table 8-161](#).

Return to the [Summary Table](#).

First nibble (0x3) in the register address is to indicated MMD register space. For register access, ignore the first nibble.

Table 8-161. OAM_RECEIVE Register Field Descriptions

Bit	Field	Type	Reset	Description
15	mr_rx_lp_valid	R	0h	This bit is used to indicate message data in registers 3.2313.11:8, 3.2314, 3.2315, 3.2316, and 3.2317 are stored and ready to be read. This bit shall self clear when register 3.2317 is read. 1 = Message data in registers are valid 0 = Message data in registers are not valid Note - 0x3 added in [15:12] to differentiate 0h = Message data in registers are not valid 1h = Message data in registers are valid
14	mr_rx_lp_toggle	R	0h	Toggle value received with message Note - 0x3 added in [15:12] to differentiate
13-12	RESERVED	R	0h	Reserved
11-8	mr_rx_lp_message_num	R	0h	Message number from link partner Note - 0x3 added in [15:12] to differentiate
7-2	RESERVED	R	0h	Reserved
1-0	mr_rx_lp_SNR	R	0h	00 = Link partner link is failing and will drop link and relink within 2 ms to 4 ms after the end of the current 100BASE-T1 OAM frame. 01 = LPI refresh is insufficient to maintain link partner SNR. Link partner requests local device to exit LPI and send idles (used only when EEE is enabled). 10 = Link partner SNR is marginal. 11 = Link partner SNR is good Note - 0x3 added in [15:12] to differentiate 0h = Link partner link is failing and will drop link and relink within 2 ms to 4 ms after the end of the current 100BASE-T1 OAM frame. 1h = LPI refresh is insufficient to maintain link partner SNR. Link partner requests local device to exit LPI and send idles (used only when EEE is enabled). 2h = Link partner SNR is marginal. 3h = Link partner SNR is good

8.6.2.1.139 OAM_RX_MESSAGE_1 Register (Offset = 390Ah) [Reset = 0h]

OAM_RX_MESSAGE_1 is shown in [Table 8-162](#).

Return to the [Summary Table](#).

First nibble (0x3) in the register address is to indicated MMD register space. For register access, ignore the first nibble.

Table 8-162. OAM_RX_MESSAGE_1 Register Field Descriptions

Bit	Field	Type	Reset	Description
15-0	mr_rx_lp_message_15_0	R	0h	Message octet 1/0. LSB transmitted first. Note - 0x3 added in [15:12] to differentiate

8.6.2.1.140 OAM_RX_MESSAGE_2 Register (Offset = 390Bh) [Reset = 0h]

OAM_RX_MESSAGE_2 is shown in [Table 8-163](#).

Return to the [Summary Table](#).

First nibble (0x3) in the register address is to indicated MMD register space. For register access, ignore the first nibble.

Table 8-163. OAM_RX_MESSAGE_2 Register Field Descriptions

Bit	Field	Type	Reset	Description
15-0	mr_rx_lp_message_31_16	R	0h	Message octet 3/2. LSB transmitted first. Note - 0x3 added in [15:12] to differentiate

8.6.2.1.141 OAM_RX_MESSAGE_3 Register (Offset = 390Ch) [Reset = 0h]

OAM_RX_MESSAGE_3 is shown in [Table 8-164](#).

Return to the [Summary Table](#).

First nibble (0x3) in the register address is to indicated MMD register space. For register access, ignore the first nibble.

Table 8-164. OAM_RX_MESSAGE_3 Register Field Descriptions

Bit	Field	Type	Reset	Description
15-0	mr_rx_lp_message_47_32	R	0h	Message octet 5/4. LSB transmitted first. Note - 0x3 added in [15:12] to differentiate

8.6.2.1.142 OAM_RX_MESSAGE_4 Register (Offset = 390Dh) [Reset = 0h]

OAM_RX_MESSAGE_4 is shown in [Table 8-165](#).

Return to the [Summary Table](#).

First nibble (0x3) in the register address is to indicated MMD register space. For register access, ignore the first nibble.

Table 8-165. OAM_RX_MESSAGE_4 Register Field Descriptions

Bit	Field	Type	Reset	Description
15-0	mr_rx_lp_message_63_48		0h	Message octet 7/6. LSB transmitted first. Note - 0x3 added in [15:12] to differentiate

8.6.2.1.143 AN_CFG Register (Offset = 7200h) [Reset = 0h]

AN_CFG is shown in [Table 8-166](#).

Return to the [Summary Table](#).

First nibble (0x7) in the register address is to indicated MMD register space. For register access, ignore the first nibble.

Table 8-166. AN_CFG Register Field Descriptions

Bit	Field	Type	Reset	Description
15-1	RESERVED	R	0h	Reserved
0	mr_main_reset	R/WSC	0h	1 = Reset link sync/autoneg Note - RW bit Note - Added 7 to [15:12] to differentiate

9 Application and Implementation

Note

Information in the following applications sections is not part of the TI component specification, and TI does not warrant its accuracy or completeness. TI's customers are responsible for determining suitability of components for their purposes, as well as validating and testing their design implementation to confirm system functionality.

9.1 Application Information

The DP83TG720R-Q1 is a single-port 1-Gbps Automotive Ethernet PHY. It supports IEEE 802.3bp and allows for connections to an Ethernet MAC through RGMII. When using the device for Ethernet applications, it is necessary to meet certain requirements for normal operation. The following subsections are intended to assist in appropriate component selection and required connections.

9.2 Typical Applications

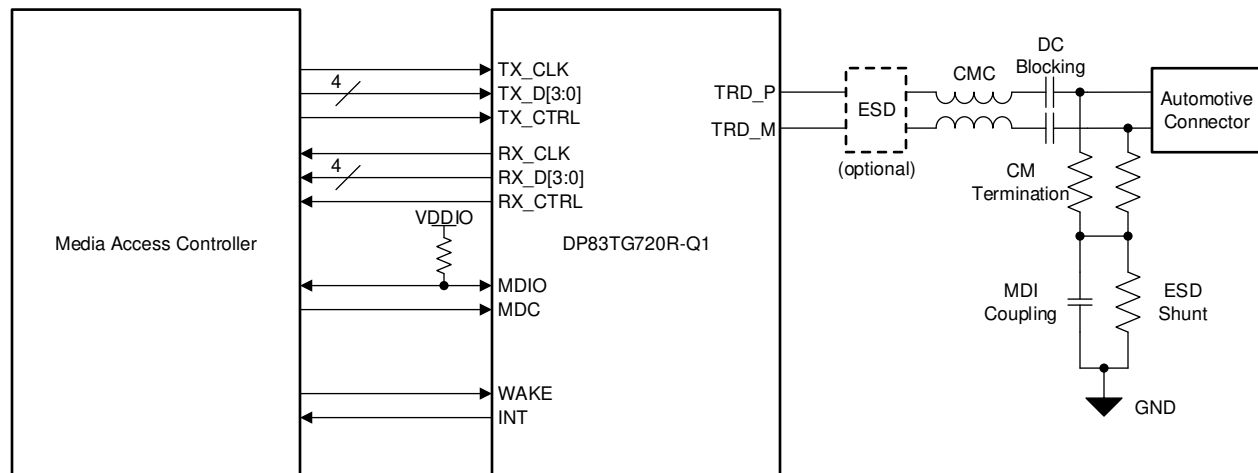

Figure 9-1. Typical Application (RGMII)

Table 9-1. Recommended Components for MDI Network

Design Parameter	Value
DC Blocking Capacitors ¹	0.1 μ F
Common-Mode Choke	Murata :DLW32MH101XT2
Common Mode Termination Resistors ¹	1 k Ω
MDI Coupling Capacitor	4.7 nF
ESD Shunt	100 k Ω

1. 1% tolerance components are recommended for margins over spec of return loss and mode conversion.

9.2.1 Design Requirements

For these typical applications, use the following as input parameters:

Table 9-2. Design Parameters

DESIGN PARAMETER	EXAMPLE VALUE
V _{DDIO}	1.8 V, 2.5 V, or 3.3 V
De-Coupling Capacitors V _{DDIO} (pin 34)	10 nF, 100 nF
De-Coupling Capacitors V _{DDIO} (pin 22)	10 nF, 100 nF, 2.2 μ F
Combined Ferrite Bead for VDDIO	BLM18HE102SN1

Table 9-2. Design Parameters (continued)

DESIGN PARAMETER	EXAMPLE VALUE
V_{DDA}	3.3 V
De-Coupling Capacitors V_{DDA} (pin 11)	10 nF, 100 nF, 2.2 μ F
Ferrite Bead for V_{DDA}	BLM18KG601SH1
V_{DD1P0}	1 V
De-Coupling Capacitors V_{DD1P0} (pin 9)	10 nF, 100 nF, 2.2 μ F
De-Coupling Capacitors V_{DDA} (pin 21)	10 nF, 100 nF, 2.2 μ F
Combined Ferrite Bead for V_{DD1P0}	BLM18KG601SH1
V_{sleep}	3.3 V
DC Blocking Capacitors ⁽¹⁾	0.1 μ F
Common-Mode Choke	Murata :DLW32MH101XT2
Common Mode Termination Resistors ⁽¹⁾	1 k Ω
MDI Coupling Capacitor	4.7 nF
ESD Shunt	100 k Ω
Reference Clock	25-MHz

(1) 1% tolerance components are recommended to improve return loss and mode conversion measurements.

10 Power Supply Recommendations

The DP83TG720R-Q1 is capable of operating with a wide range of IO supply voltages (3.3 V, 2.5 V, or 1.8 V). No power supply sequencing is required. The recommended power supply de-coupling network is shown in following figure :

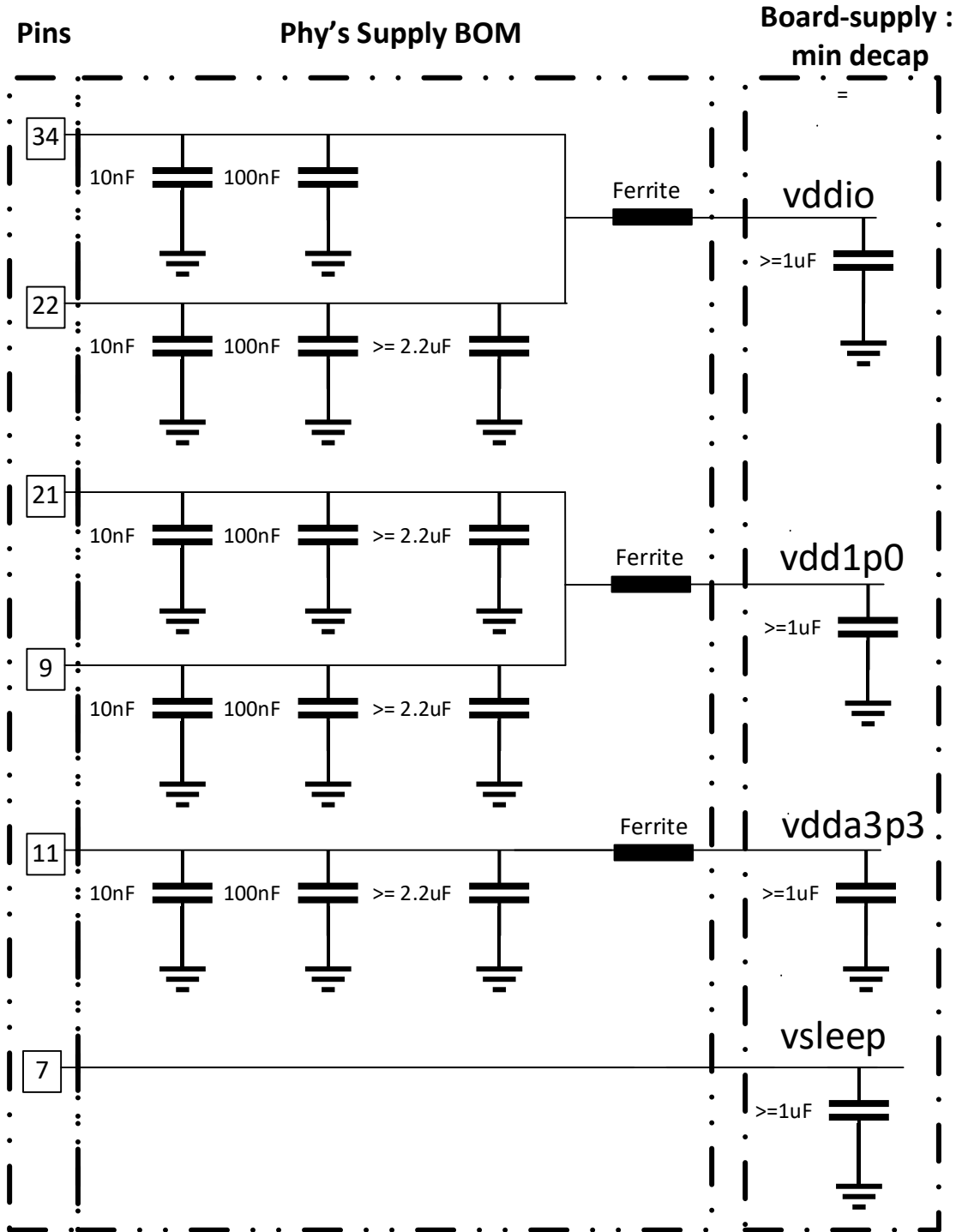

Figure 10-1. Recommended Supply De-Coupling Network (if sleep mode is used in the application)

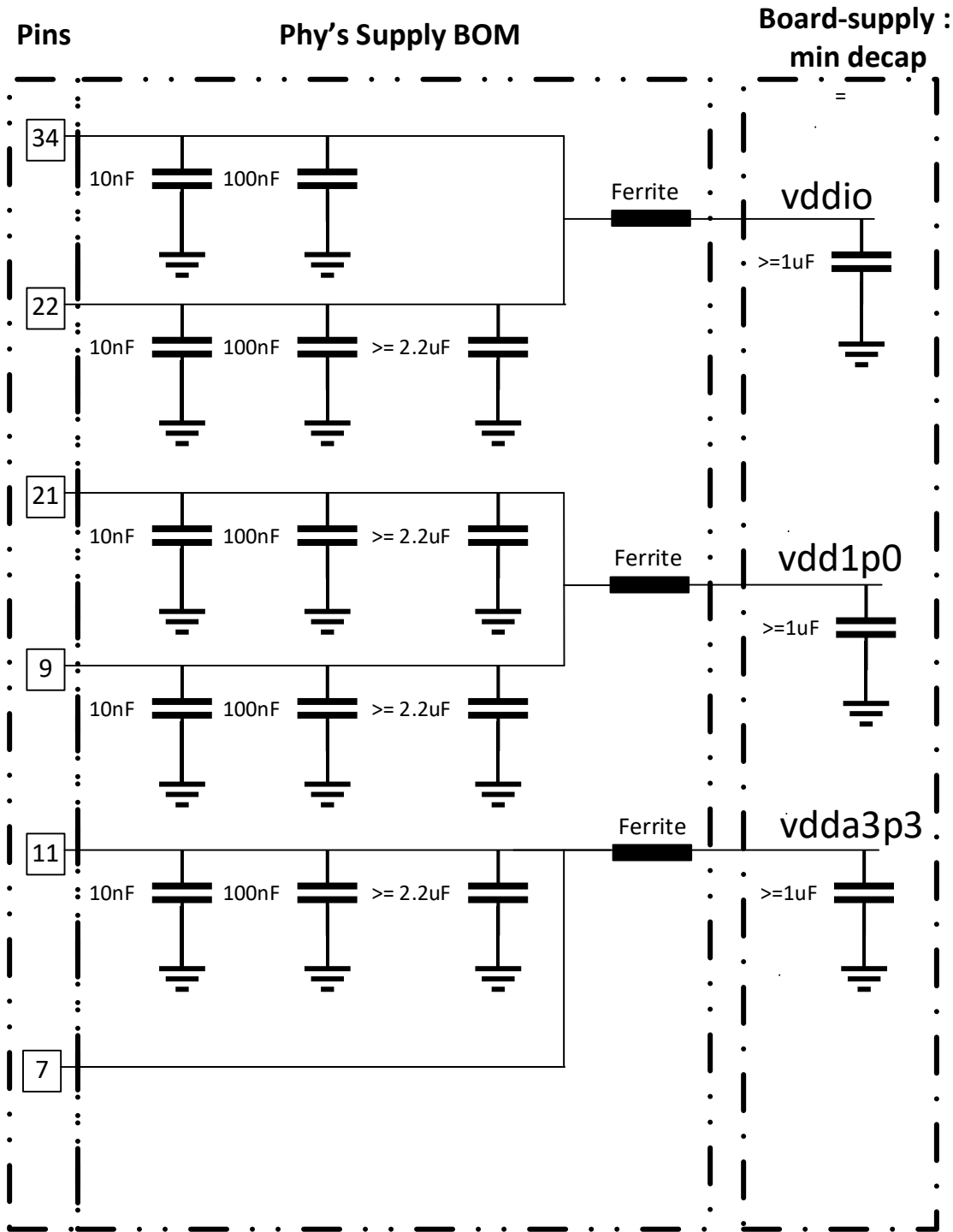

Figure 10-2. Recommended Supply De-Coupling Network (if sleep mode is not used in application)

Table 10-1. Recommended Components for Power Network

Design Parameter	Value
V_{DDIO}	1.8 V, 2.5 V, or 3.3 V
De-Coupling Capacitors V_{DDIO} (pin 34)	10 nF, 100 nF
De-Coupling Capacitors V_{DDIO} (pin 22)	10 nF, 100 nF, 2.2 μF
Combined Ferrite Bead for VDDIO	BLM18HE102SN1

Table 10-1. Recommended Components for Power Network (continued)

Design Parameter	Value
V_{DDA}	3.3 V
De-Coupling Capacitors V_{DDA} (pin 11)	10 nF, 100 nF, 2.2uF
Ferrite Bead for V_{DDA}	BLM18KG601SH1
V_{DD1p0}	1 V
De-Coupling Capacitors V_{DD1P0} (pin 9)	10 nF, 100 nF, 2.2uF
De-Coupling Capacitors V_{DDA} (pin 21)	10 nF, 100 nF, 2.2uF
Combined Ferrite Bead for V_{DD1P0}	BLM18KG601SH1
V_{sleep}	3.3 V

Note

For recommendation on LDOs for V_{DD1p0} and V_{sleep} , please refer to the [DP83TC811](#), [DP83TG730 Rollover Document](#) application report.

11 Compatibility with TI's 100BT1 PHY

Following table shows pin comparison between DP83TC811 and DP83TG720. Pins highlighted in bold need attention while designing a common board for both 100BT1 and 1000BT1 PHY. 100BT1 and 1000BT1 PHY's different BOM requirements can also be taken care by a common board.

Details and recommendation for common board design can be found in [DP83TC811](#), [DP83TG720 Rollover Document](#) application report.

Table 11-1. Pin Comparison Table

Pin No.	DP83TC811	DP83TG720
1	MDC	MDC
2	INT_N	INT_N
3	RESET_N	RESET_N
4	XO	XO
5	XI	XI
6	LED_1	LED_1
7	EN	VSLEEP
8	WAKE	WAKE
9	DNC	VDD1P0
10	INH	INH
11	VDDA	VDDA
12	TRD_P	TRD_P
13	TRD_M	TRD_M
14	RX_ER	STRP1
15	RX_DV	RX_CTRL
16	CLKOUT	CLKOUT
17	TCK	DNC
18	TDO	DNC
19	TMS	DNC
20	TCK	DNC
21	DNC	VDD1P0
22	VDDIO	VDDIO
23	RX_D3	RX_D3
24	RX_D2	RX_D2
25	RX_D1	RX_D1
26	RX_D0	RX_D0
27	RX_CLK	RX_CLK
28	TXCLK	TXCLK
29	TX_EN	TX_CTRL
30	TX_D3	TX_D3
31	TX_D2	TX_D2
32	TX_D1	TX_D1
33	TX_D0	TX_D0
34	TX_ER	VDDIO
35	LED_0	LED_0
36	MDIO	MDIO

12 Layout

12.1 Layout Guidelines

12.1.1 Signal Traces

PCB traces are lossy and long traces can degrade signal quality. Traces should be kept short as possible. Unless mentioned otherwise, all signal traces should be 50- Ω , single-ended impedance. Differential traces should be 50- Ω single-ended and 100- Ω differential. Take care to ensure impedance is controlled throughout. Impedance discontinuities will cause reflections leading to emissions and signal integrity issues. Stubs should be avoided on all signal traces, especially differential signal pairs.

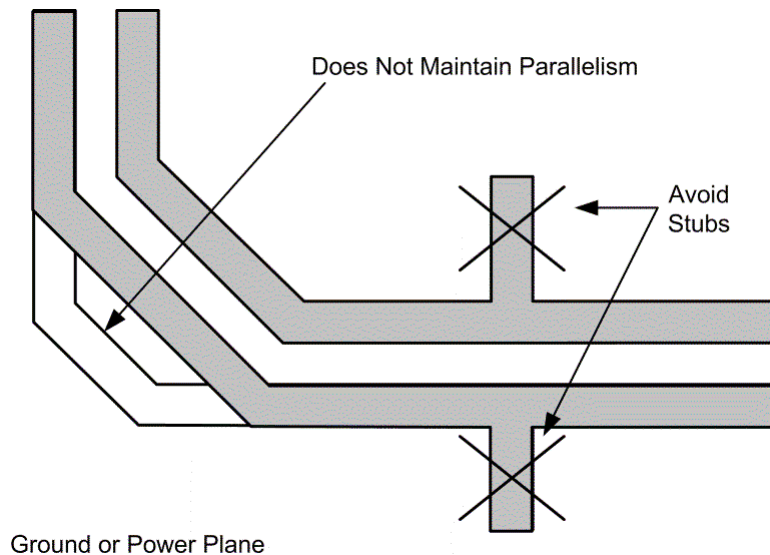

Figure 12-1. Differential Signal Trace Routing

Within the differential pairs, trace lengths should be run parallel to each other and matched in length. Matched lengths minimize delay differences, avoiding an increase in common mode noise and emissions. Length matching is also important for MAC interface connections. All transmit signal traces should be length matched to each other and all receive signal traces should be length matched to each other.

Ideally, there should be no crossover or vias on signal path traces. Vias present impedance discontinuities and should be minimized when possible. Route trace pairs on the same layer. Signals on different layers should not cross each other without at least one return path plane between them. Differential pairs should always have a constant coupling distance between them. For convenience and efficiency, TI recommends routing critical signals first (that is, MDI differential pairs, reference clock, and MAC IF traces).

12.1.2 Return Path

A general best practice is to have a solid return path beneath all signal traces. This return path can be a continuous ground or DC power plane. Reducing the width of the return path can potentially affect the impedance of the signal trace. This effect is more prominent when the width of the return path is comparable to the width of the signal trace. Breaks in return path between the signal traces should be avoided at all cost. A signal crossing a split plane may cause unpredictable return path currents and could impact signal quality and result in emissions issues.

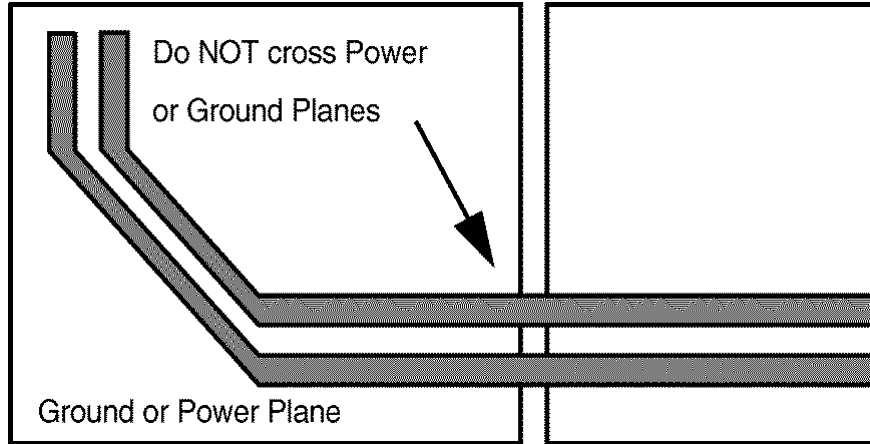

Figure 12-2. Power and Ground Plane Breaks

12.1.3 Physical Medium Attachment

There must be no metal running beneath the common-mode choke. CMCs can inject noise into metal beneath them, which can affect the emissions and immunity performance of the system. Because the DP83TG720R-Q1 is a voltage mode line driver, no external termination resistors are required. The ESD shunt and MDI coupling capacitor should be connected to ground. Ensure that the common mode termination resistors are 1% tolerance or better to improve differential coupling.

12.1.4 Metal Pour

All metal pours that are not signals or power must be tied to ground. There must be no floating metal in the system, and there must be no metal between differential traces.

12.1.5 PCB Layer Stacking

To meet signal integrity and performance requirements, minimum four-layer PCB is recommended. However, a six-layer PCB and above should be used when possible.

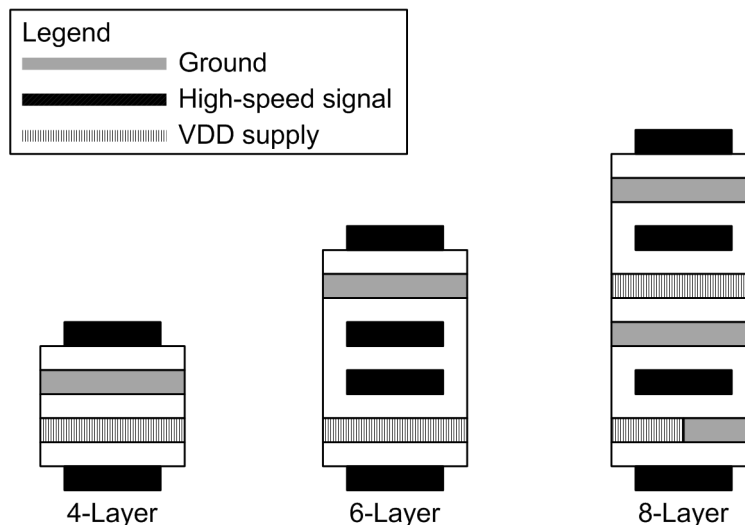

Figure 12-3. Recommended PCB Layer Stack-Up

13 Device and Documentation Support

13.1 Receiving Notification of Documentation Updates

To receive notification of documentation updates, navigate to the device product folder on ti.com. Click on *Subscribe to updates* to register and receive a weekly digest of any product information that has changed. For change details, review the revision history included in any revised document.

13.2 Support Resources

TI E2E™ [support forums](#) are an engineer's go-to source for fast, verified answers and design help — straight from the experts. Search existing answers or ask your own question to get the quick design help you need.

Linked content is provided "AS IS" by the respective contributors. They do not constitute TI specifications and do not necessarily reflect TI's views; see TI's [Terms of Use](#).

13.3 Trademarks

TI E2E™ is a trademark of Texas Instruments.

All trademarks are the property of their respective owners.

13.4 Electrostatic Discharge Caution



This integrated circuit can be damaged by ESD. Texas Instruments recommends that all integrated circuits be handled with appropriate precautions. Failure to observe proper handling and installation procedures can cause damage.

ESD damage can range from subtle performance degradation to complete device failure. Precision integrated circuits may be more susceptible to damage because very small parametric changes could cause the device not to meet its published specifications.

13.5 Glossary

[TI Glossary](#) This glossary lists and explains terms, acronyms, and definitions.

14 Mechanical, Packaging, and Orderable Information

The following pages include mechanical, packaging, and orderable information. This information is the most current data available for the designated devices. This data is subject to change without notice and revision of this document. For browser-based versions of this data sheet, refer to the left navigation.

14.1 Package Option Addendum

14.1.1 Packaging Information

Orderable Device	Status ⁽¹⁾	Package Type	Package Drawing	Pins	Package Qty	Eco Plan ⁽²⁾	Lead/Ball Finish ⁽⁴⁾	MSL Peak Temp ⁽³⁾	Op Temp (°C)	Device Marking ^{(5) (6)}
PDP83TG720SWCST Q1	EARLY SAMPLE	VQFN	RHA	36	250	RoHS	NiPdAu	MSL3-260C	-40 to 125	
DP83TG720RWRHAT Q1	ACTIVE	VQFN	RHA	36	250	RoHS	NiPdAu	MSL3-260C	-40 to 125	720R
DP83TG720RWRHAR Q1	ACTIVE	VQFN	RHA	36	2500	RoHS	NiPdAu	MSL3-260C	-40 to 125	720R

(1) The marketing status values are defined as follows:

ACTIVE: Product device recommended for new designs.

LIFEBUY: TI has announced that the device will be discontinued, and a lifetime-buy period is in effect.

NRND: Not recommended for new designs. Device is in production to support existing customers, but TI does not recommend using this part in a new design.

PRE_PROD Unannounced device, not in production, not available for mass market, nor on the web, samples not available.

PREVIEW: Device has been announced but is not in production. Samples may or may not be available.

OBSOLETE: TI has discontinued the production of the device.

(2) Eco Plan - The planned eco-friendly classification: Pb-Free (RoHS), Pb-Free (RoHS Exempt), or Green (RoHS & no Sb/Br) - please check <http://www.ti.com/productcontent> for the latest availability information and additional product content details.

TBD: The Pb-Free/Green conversion plan has not been defined.

Pb-Free (RoHS): TI's terms "Lead-Free" or "Pb-Free" mean semiconductor products that are compatible with the current RoHS requirements for all 6 substances, including the requirement that lead not exceed 0.1% by weight in homogeneous materials. Where designed to be soldered at high temperatures, TI Pb-Free products are suitable for use in specified lead-free processes.

Pb-Free (RoHS Exempt): This component has a RoHS exemption for either 1) lead-based flip-chip solder bumps used between the die and package, or 2) lead-based die adhesive used between the die and leadframe. The component is otherwise considered Pb-Free (RoHS compatible) as defined above.

Green (RoHS & no Sb/Br): TI defines "Green" to mean Pb-Free (RoHS compatible), and free of Bromine (Br) and Antimony (Sb) based flame retardants (Br or Sb do not exceed 0.1% by weight in homogeneous material)

(3) MSL, Peak Temp. -- The Moisture Sensitivity Level rating according to the JEDEC industry standard classifications, and peak solder temperature.

(4) Lead/Ball Finish - Orderable Devices may have multiple material finish options. Finish options are separated by a vertical ruled line. Lead/Ball Finish values may wrap to two lines if the finish value exceeds the maximum column width.

(5) There may be additional marking, which relates to the logo, the lot trace code information, or the environmental category on the device

(6) Multiple Device markings will be inside parentheses. Only one Device Marking contained in parentheses and separated by a "~" will appear on a device. If a line is indented then it is a continuation of the previous line and the two combined represent the entire Device Marking for that device.

Important Information and Disclaimer: The information provided on this page represents TI's knowledge and belief as of the date that it is provided. TI bases its knowledge and belief on information provided by third parties, and makes no representation or warranty as to the accuracy of such information. Efforts are underway to better integrate information from third parties. TI has taken and continues to take reasonable steps to provide representative and accurate information but may not have conducted destructive testing or chemical analysis on incoming materials and chemicals. TI and TI suppliers consider certain information to be proprietary, and thus CAS numbers and other limited information may not be available for release.

DP83TG720R-Q1

SNLS603B – DECEMBER 2020 – REVISED MARCH 2021

In no event shall TI's liability arising out of such information exceed the total purchase price of the TI part(s) at issue in this document sold by TI to Customer on an annual basis.

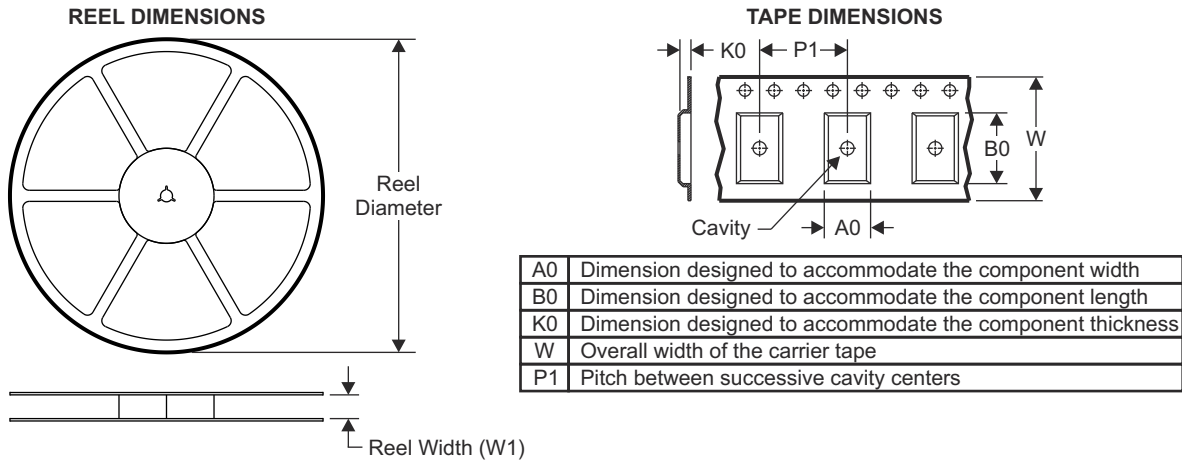
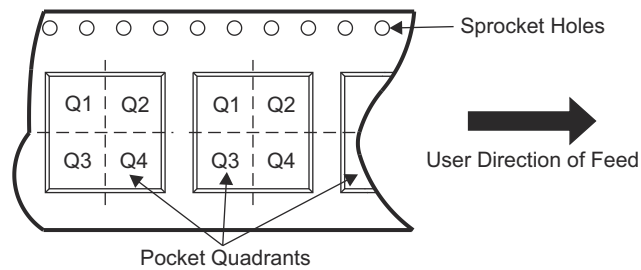
14.1.2 Tape and Reel Information

QUADRANT ASSIGNMENTS FOR PIN 1 ORIENTATION IN TAPE

Device	Package Type	Package Drawing	Pins	SPQ	Reel Diameter (mm)	Reel Width W1 (mm)	A0 (mm)	B0 (mm)	K0 (mm)	P1 (mm)	W (mm)	Pin1 Quadrant
PDP83TG720SWCSTQ1	VQFN	RHA	36	250	Call TI	Call TI	Call TI	Call TI	Call TI	Call TI	Call TI	Call TI
DP83TG720RWRHATQ1	VQFN	RHA	36	250	180	16.4	6.3	6.3	1.1	12	16	Q2
DP83TG720RWRHARQ1	VQFN	RHA	36	2500	330	16.4	6.3	6.3	1.1	12	16	Q2

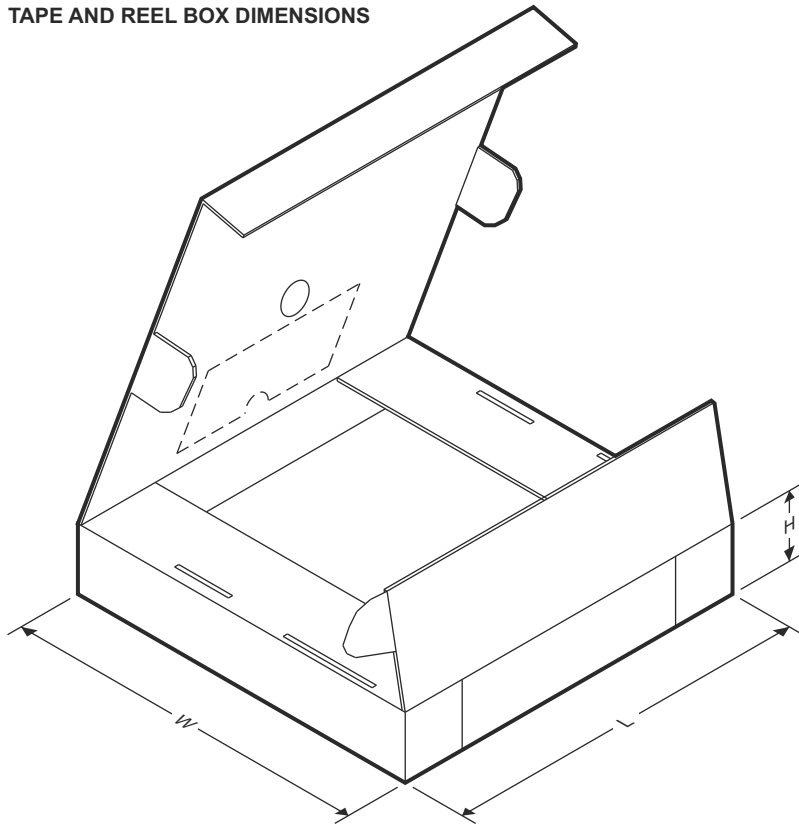
TAPE AND REEL BOX DIMENSIONS



Device	Package Type	Package Drawing	Pins	SPQ	Length (mm)	Width (mm)	Height (mm)
DP83TG720RWRHATQ1	VQFN	RHA	36	250	210	185	35
DP83TG720RWRHARQ1	VQFN	RHA	36	2500	367	367	35

RHA0036A

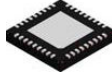

PACKAGE OUTLINE

VQFN - 1 mm max height

PLASTIC QUAD FLATPACK - NO LEAD

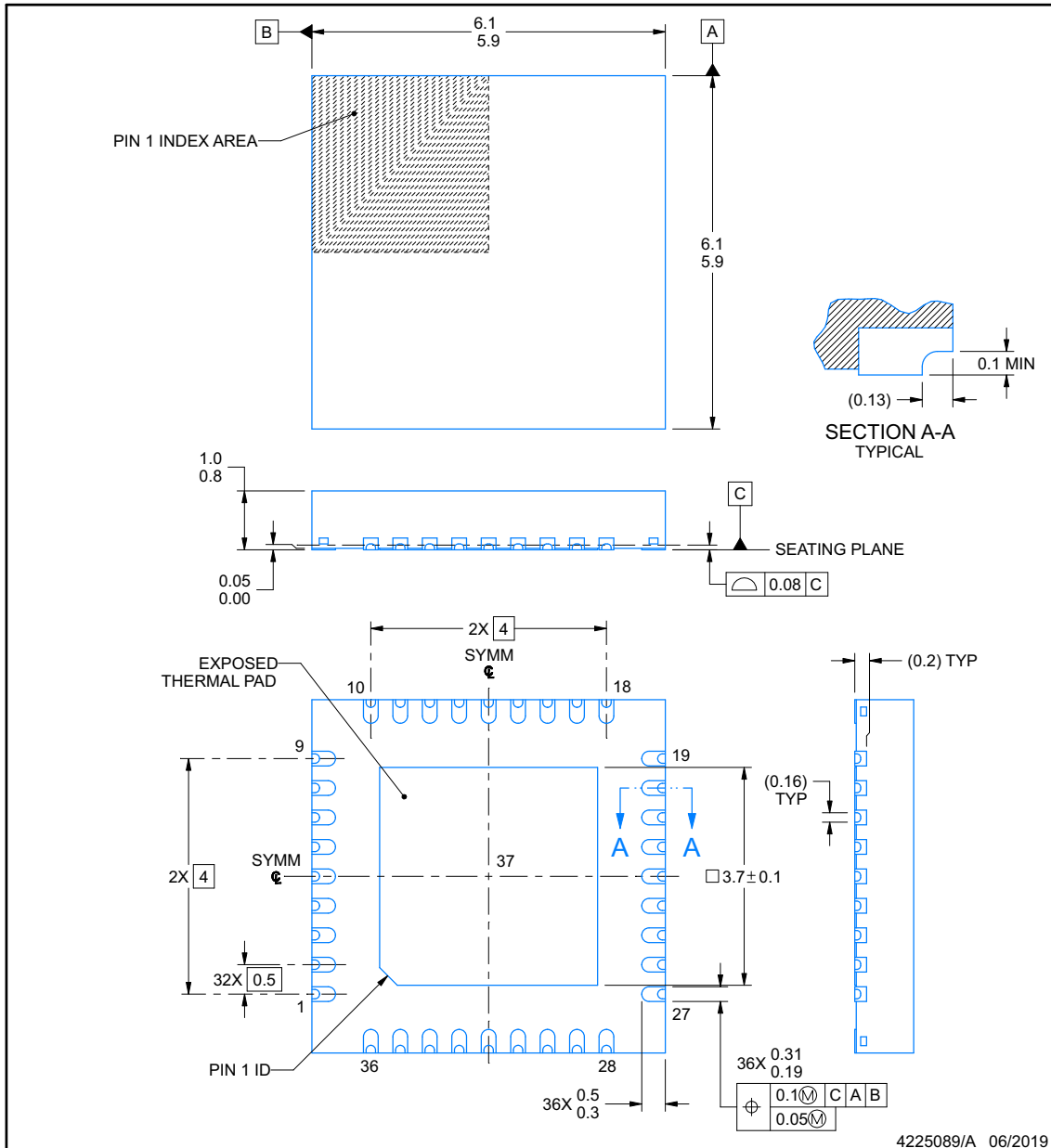

NOTES:

1. All linear dimensions are in millimeters. Any dimensions in parenthesis are for reference only. Dimensioning and tolerancing per ASME Y14.5M.
2. This drawing is subject to change without notice.
3. The package thermal pad must be soldered to the printed circuit board for thermal and mechanical performance.

EXAMPLE BOARD LAYOUT

RHA0036A

VQFN - 1 mm max height

PLASTIC QUAD FLATPACK - NO LEAD

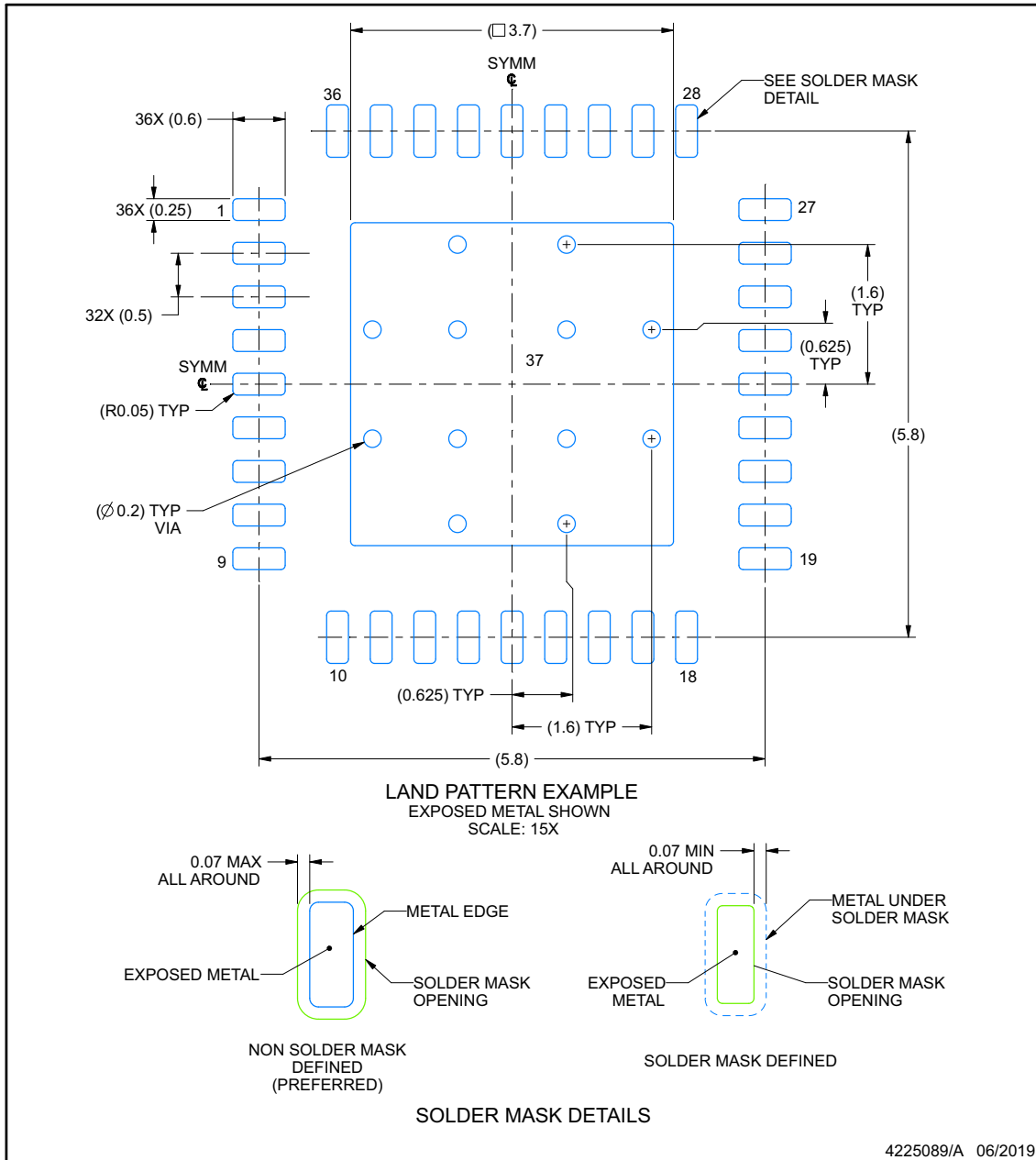

NOTES: (continued)

4. This package is designed to be soldered to a thermal pad on the board. For more information, see Texas Instruments literature number SLUA271 (www.ti.com/lit/sluea271).
5. Vias are optional depending on application, refer to device data sheet. If any vias are implemented, refer to their locations shown on this view. It is recommended that vias under paste be filled, plugged or tented.

EXAMPLE STENCIL DESIGN

RHA0036A

VQFN - 1 mm max height

PLASTIC QUAD FLATPACK - NO LEAD

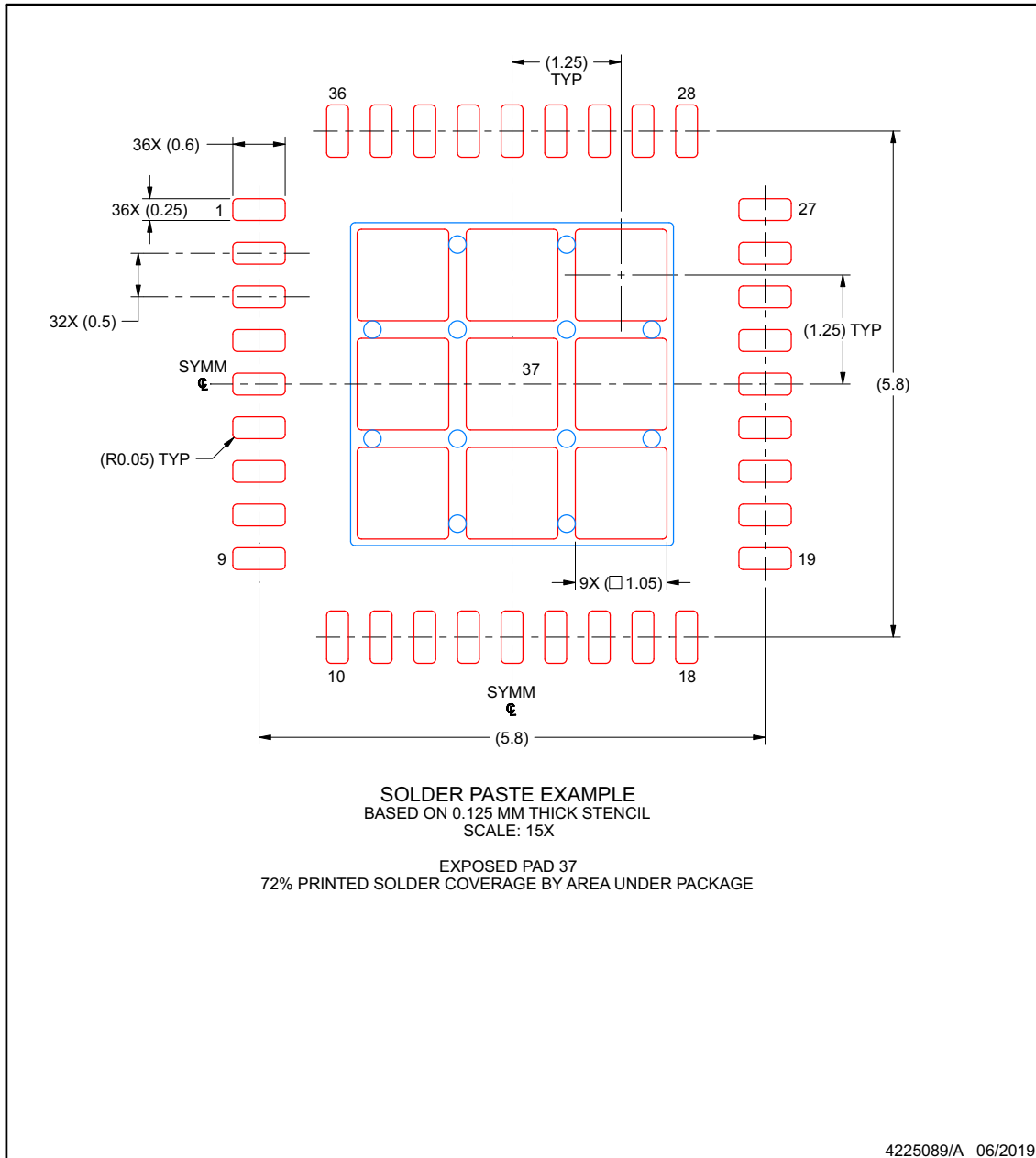

NOTES: (continued)

- 6. Laser cutting apertures with trapezoidal walls and rounded corners may offer better paste release. IPC-7525 may have alternate design recommendations.

PACKAGING INFORMATION

Orderable Device	Status (1)	Package Type	Package Drawing	Pins	Package Qty	Eco Plan (2)	Lead finish/ Ball material (6)	MSL Peak Temp (3)	Op Temp (°C)	Device Marking (4/5)	Samples
DP83TG720RWRHARQ1	ACTIVE	VQFN	RHA	36	2500	RoHS & Green	NIPDAU	Level-3-260C-168 HR	-40 to 125	720R	Samples
DP83TG720RWRHATQ1	ACTIVE	VQFN	RHA	36	250	RoHS & Green	NIPDAU	Level-3-260C-168 HR	-40 to 125	720R	Samples

(1) The marketing status values are defined as follows:

ACTIVE: Product device recommended for new designs.

LIFEBUY: TI has announced that the device will be discontinued, and a lifetime-buy period is in effect.

NRND: Not recommended for new designs. Device is in production to support existing customers, but TI does not recommend using this part in a new design.

PREVIEW: Device has been announced but is not in production. Samples may or may not be available.

OBSOLETE: TI has discontinued the production of the device.

(2) **RoHS:** TI defines "RoHS" to mean semiconductor products that are compliant with the current EU RoHS requirements for all 10 RoHS substances, including the requirement that RoHS substance do not exceed 0.1% by weight in homogeneous materials. Where designed to be soldered at high temperatures, "RoHS" products are suitable for use in specified lead-free processes. TI may reference these types of products as "Pb-Free".

RoHS Exempt: TI defines "RoHS Exempt" to mean products that contain lead but are compliant with EU RoHS pursuant to a specific EU RoHS exemption.

Green: TI defines "Green" to mean the content of Chlorine (Cl) and Bromine (Br) based flame retardants meet JS709B low halogen requirements of <=1000ppm threshold. Antimony trioxide based flame retardants must also meet the <=1000ppm threshold requirement.

(3) MSL, Peak Temp. - The Moisture Sensitivity Level rating according to the JEDEC industry standard classifications, and peak solder temperature.

(4) There may be additional marking, which relates to the logo, the lot trace code information, or the environmental category on the device.

(5) Multiple Device Markings will be inside parentheses. Only one Device Marking contained in parentheses and separated by a "~" will appear on a device. If a line is indented then it is a continuation of the previous line and the two combined represent the entire Device Marking for that device.

(6) Lead finish/Ball material - Orderable Devices may have multiple material finish options. Finish options are separated by a vertical ruled line. Lead finish/Ball material values may wrap to two lines if the finish value exceeds the maximum column width.

Important Information and Disclaimer:The information provided on this page represents TI's knowledge and belief as of the date that it is provided. TI bases its knowledge and belief on information provided by third parties, and makes no representation or warranty as to the accuracy of such information. Efforts are underway to better integrate information from third parties. TI has taken and continues to take reasonable steps to provide representative and accurate information but may not have conducted destructive testing or chemical analysis on incoming materials and chemicals. TI and TI suppliers consider certain information to be proprietary, and thus CAS numbers and other limited information may not be available for release.

In no event shall TI's liability arising out of such information exceed the total purchase price of the TI part(s) at issue in this document sold by TI to Customer on an annual basis.

IMPORTANT NOTICE AND DISCLAIMER

TI PROVIDES TECHNICAL AND RELIABILITY DATA (INCLUDING DATASHEETS), DESIGN RESOURCES (INCLUDING REFERENCE DESIGNS), APPLICATION OR OTHER DESIGN ADVICE, WEB TOOLS, SAFETY INFORMATION, AND OTHER RESOURCES "AS IS" AND WITH ALL FAULTS, AND DISCLAIMS ALL WARRANTIES, EXPRESS AND IMPLIED, INCLUDING WITHOUT LIMITATION ANY IMPLIED WARRANTIES OF MERCHANTABILITY, FITNESS FOR A PARTICULAR PURPOSE OR NON-INFRINGEMENT OF THIRD PARTY INTELLECTUAL PROPERTY RIGHTS.

These resources are intended for skilled developers designing with TI products. You are solely responsible for (1) selecting the appropriate TI products for your application, (2) designing, validating and testing your application, and (3) ensuring your application meets applicable standards, and any other safety, security, or other requirements. These resources are subject to change without notice. TI grants you permission to use these resources only for development of an application that uses the TI products described in the resource. Other reproduction and display of these resources is prohibited. No license is granted to any other TI intellectual property right or to any third party intellectual property right. TI disclaims responsibility for, and you will fully indemnify TI and its representatives against, any claims, damages, costs, losses, and liabilities arising out of your use of these resources.

TI's products are provided subject to TI's Terms of Sale (<https://www.ti.com/legal/termsofsale.html>) or other applicable terms available either on [ti.com](https://www.ti.com) or provided in conjunction with such TI products. TI's provision of these resources does not expand or otherwise alter TI's applicable warranties or warranty disclaimers for TI products.

Mailing Address: Texas Instruments, Post Office Box 655303, Dallas, Texas 75265
Copyright © 2021, Texas Instruments Incorporated