

# DHS50A

DH S 50 A 05 □

① ② ③ ④ ⑤ ⑥



RoHS

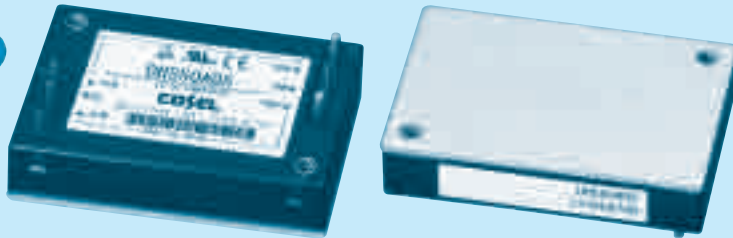

\*Providing heat sink as option

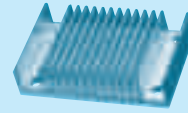

- ① Series name
- ② Single output
- ③ Output wattage
- ④ A : DC60-160V
- ⑤ Output voltage
- ⑥ Optional
- T : with Mounting hole (φ 3.4 thru)

MODEL	DHS50A05	DHS50A12	DHS50A15	DHS50A24
MAX OUTPUT WATTAGE[W]	50.0	50.4	51.0	50.4
DC OUTPUT	5V 10A	12V 4.2A	15V 3.4A	24V 2.1A

## SPECIFICATIONS

	MODEL	DHS50A05	DHS50A12	DHS50A15	DHS50A24	
INPUT	VOLTAGE[V]	DC60 - 160				
	CURRENT[A]	0.55A	0.55A	0.55A	0.55A	
	EFFICIENCY[%]	84.0typ	86.0typ	86.0typ	86.0typ	
OUTPUT	VOLTAGE[V]	5	12	15	24	
	CURRENT[A]	10	4.2	3.4	2.1	
	LINE REGULATION[mV]	10max	24max	30max	48max	
	LOAD REGULATION[mV]	10max	24max	30max	48max	
	RIPPLE[mVp-p]	0 to +100°C *2	80max	120max	120max	120max
		-40 to 0°C *2	120max	150max	150max	150max
		0 to 15% Load *2	160max	240max	240max	240max
	RIPPLE NOISE[mVp-p]	0 to +100°C *2	120max	150max	150max	150max
		-40 to 0°C *2	200max	200max	200max	250max
		0 to 15% Load *2	240max	300max	300max	300max
	TEMPERATURE REGULATION[mV]	0 to +65°C	50max	120max	150max	240max
		-40 to +100°C	100max	240max	300max	480max
	DRIFT[mV]	*3	20max	40max	60max	90max
START-UP TIME[ms]	200max (DCIN 110V, Io=100%)					
OUTPUT VOLTAGE ADJUSTMENT RANGE[V]	*4	Fixed (TRM pin open), adjustable by external VR or external voltage				
		4.50 - 6.00	10.80 - 13.20	13.50 - 16.50	21.60 - 26.40	
OUTPUT VOLTAGE SETTING[V]		4.97 - 5.13	11.91 - 12.29	14.76 - 15.24	23.62 - 24.38	
PROTECTION CIRCUIT AND OTHERS	OVERCURRENT PROTECTION	Works over 105% of rating and recovers automatically				
	OVERVOLTAGE PROTECTION[V]	6.30 - 7.60	13.90 - 17.55	17.25 - 21.75	27.60 - 34.80	
	REMOTE SENSING	nothing				
	REMOTE ON/OFF	Provided (Negative Logic L : ON, H :OFF)				
ISOLATION	INPUT-OUTPUT	AC3,000V 1minute, Cutoff current = 10mA, DC500V 50MΩ min (20±15°C)				
	INPUT-FG	AC2,000V 1minute, Cutoff current = 10mA, DC500V 50MΩ min (20±15°C)				
	OUTPUT-FG	AC500V 1minute, Cutoff current = 100mA, DC500V 50MΩ min (20±15°C)				
ENVIRONMENT	OPERATING TEMP., HUMID. AND ALTITUDE	-40 to +100°C (On aluminum base plate), 20 - 95%RH (Non condensing) (Refer to DERATING CURVE), 3,000m (10,000 feet) max				
	STORAGE TEMP., HUMID. AND ALTITUDE	-40 to +100°C, 20 - 95%RH (Non condensing), 9,000m (30,000 feet) max				
	VIBRATION	10 - 55Hz, 49.0m/s <sup>2</sup> (5G), 3minutes period, 60minutes each along X, Y and Z axis Complies with IEC61373 Category 1 Class B				
	IMPACT	196.1m/s <sup>2</sup> (20G), 11ms, once each along X, Y and Z axis Complies with IEC61373 Category 1 Class B				
SAFETY	AGENCY APPROVALS	UL60950-1, C-UL (CSA60950-1), EN60950-1				
OTHERS	CASE SIZE/WEIGHT	58.4 × 12.7 × 37.3mm [2.3 × 0.5 × 1.47 inches] (W × H × D) / 60g max				
	COOLING METHOD	Conduction cooling (e.g. heat radiation from the aluminum base plate to the attached heat sink)				

\*1 At rated input(DC110V) and rated load.  
 \*2 Ripple and ripple noise is measured by using measuring board. Refer to the manual  
 \*3 Drift is the change in DC output for an eight hour period after a half-hour warm-up at 25°C, with the input voltage held constant at the rated input/output.  
 \*4 Refer to the manual for input range.

External view



※ Dimensions in mm, [ ]=inches  
 ※ Div. : 0.2inch

- ※ Tolerance : ±0.3 [±0.012]
- ※ Weight : 60g max
- ※ Dimensions in mm, [ ]=inches
- ※ Mounting hole screwing torque : 0.49N · m (5.0kgf · cm) max

# DHS100A

DH S 100 A 05 -□

① ② ③ ④ ⑤ ⑥



RoHS

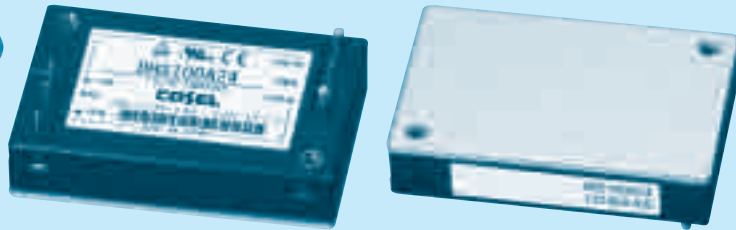

\*Providing heat sink as option

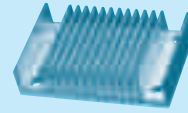

- ① Series name
- ② Single output
- ③ Output wattage
- ④ A : DC60-160V
- ⑤ Output voltage
- ⑥ Optional
- T : with Mounting hole (φ 3.4 thru)

MODEL	DHS100A05	DHS100A12	DHS100A15	DHS100A24
MAX OUTPUT WATTAGE[W]	100.0	100.8	100.5	100.8
DC OUTPUT	5V 20A	12V 8.4A	15V 6.7A	24V 4.2A

## SPECIFICATIONS

	MODEL	DHS100A05	DHS100A12	DHS100A15	DHS100A24	
INPUT	VOLTAGE[V]	DC60 - 160				
	CURRENT[A]	1.1A	1.1A	1.1A	1.1A	
	EFFICIENCY[%]	85.0typ	88.0typ	88.0typ	88.0typ	
OUTPUT	VOLTAGE[V]	5	12	15	24	
	CURRENT[A]	20	8.4	6.7	4.2	
	LINE REGULATION[mV]	10max	24max	30max	48max	
	LOAD REGULATION[mV]	10max	24max	30max	48max	
	RIPPLE[mVp-p]	0 to +100°C *2	80max	120max	120max	120max
		-40 to 0°C *2	120max	150max	150max	150max
		0 to 15% Load *2	160max	240max	240max	240max
	RIPPLE NOISE[mVp-p]	0 to +100°C *2	120max	150max	150max	150max
		-40 to 0°C *2	200max	200max	200max	250max
		0 to 15% Load *2	240max	300max	300max	300max
	TEMPERATURE REGULATION[mV]	0 to +65°C	50max	120max	150max	240max
		-40 to +100°C	100max	240max	300max	480max
	DRIFT[mV]	*3	20max	40max	60max	90max
START-UP TIME[ms]	200max (DCIN 110V, Io=100%)					
OUTPUT VOLTAGE ADJUSTMENT RANGE[V]	*4	Fixed (TRM pin open), adjustable by external VR or external voltage				
		4.50 - 6.00	10.80 - 13.20	13.50 - 16.50	21.60 - 26.40	
OUTPUT VOLTAGE SETTING[V]		4.97 - 5.13	11.91 - 12.29	14.76 - 15.24	23.62 - 24.38	
PROTECTION CIRCUIT AND OTHERS	OVERCURRENT PROTECTION	Works over 105% of rating and recovers automatically				
	OVERVOLTAGE PROTECTION[V]	6.30 - 7.60	13.90 - 17.55	17.25 - 21.75	27.60 - 34.80	
	REMOTE SENSING	nothing				
	REMOTE ON/OFF	Provided (Negative Logic L : ON, H :OFF)				
ISOLATION	INPUT-OUTPUT	AC3,000V 1minute, Cutoff current = 10mA, DC500V 50MΩ min (20±15°C)				
	INPUT-FG	AC2,000V 1minute, Cutoff current = 10mA, DC500V 50MΩ min (20±15°C)				
	OUTPUT-FG	AC500V 1minute, Cutoff current = 100mA, DC500V 50MΩ min (20±15°C)				
ENVIRONMENT	OPERATING TEMP.,HUMID.AND ALTIUDE	-40 to +100°C (On aluminum base plate), 20 - 95%RH (Non condensing) (Refer to DERATING CURVE), 3,000m (10,000 feet) max				
	STORAGE TEMP.,HUMID.AND ALTIUDE	-40 to +100°C, 20 - 95%RH (Non condensing), 9,000m (30,000 feet) max				
	VIBRATION	10 - 55Hz, 49.0m/s² (5G), 3minutes period, 60minutes each along X, Y and Z axis Complies with IEC61373 Category 1 Class B				
	IMPACT	196.1m/s² (20G), 11ms, once each along X, Y and Z axis Complies with IEC61373 Category 1 Class B				
SAFETY	AGENCY APPROVALS	UL60950-1, C-UL (CSA60950-1), EN60950-1				
OTHERS	CASE SIZE/WEIGHT	58.4 X 12.7 X 37.3mm [2.3 X 0.5 X 1.47 inches] (W X H X D) / 60g max				
	COOLING METHOD	Conduction cooling (e.g. heat radiation from the aluminum base plate to the attached heat sink)				

\*1 At rated input(DC110V) and rated load.  
 \*2 Ripple and ripple noise is measured by using measuring board. Refer to the manual.  
 \*3 Drift is the change in DC output for an eight hour period after a half-hour warm-up at 25°C, with the input voltage held constant at the rated input/output.  
 \*4 Refer to the manual for input range.

External view

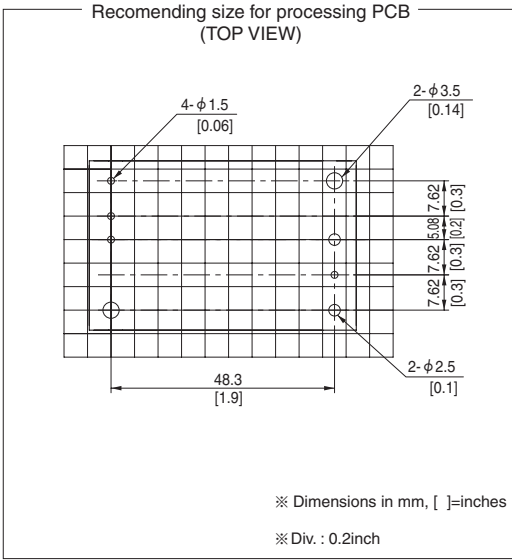
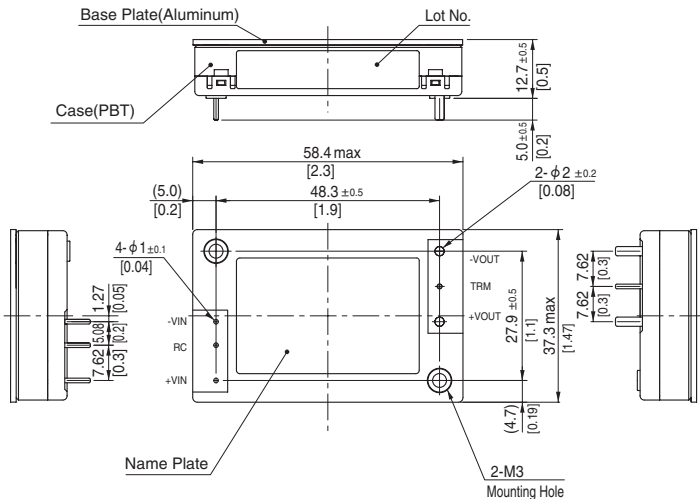

※ Dimensions in mm, [ ]=inches  
 ※ Div. : 0.2inch

- ※ Tolerance : ±0.3 [±0.012]
- ※ Weight : 60g max
- ※ Dimensions in mm, [ ]=inches
- ※ Mounting hole screwing torque : 0.49N · m (5.0kgf · cm) max

# DHS200A

DH S 200 A 05 -□

① ② ③ ④ ⑤ ⑥

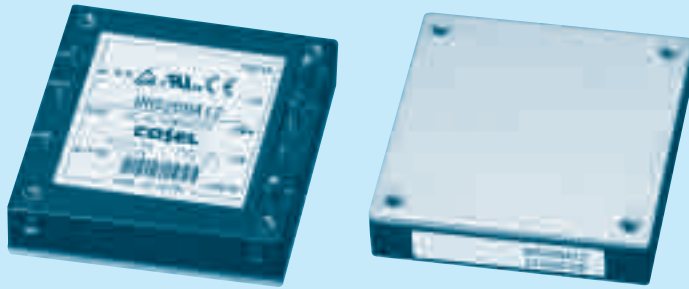

\*Providing heat sink as option

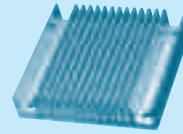

- ① Series name
- ② Single output
- ③ Output wattage
- ④ A : DC60-160V
- ⑤ Output voltage
- ⑥ Optional
- T : with Mounting hole (φ 3.4 thru)

MODEL	DHS200A05	DHS200A12	DHS200A15	DHS200A24
MAX OUTPUT WATTAGE[W]	200.0	200.4	201.0	201.6
DC OUTPUT	5V 40A	12V 16.7A	15V 13.4A	24V 8.4A

## SPECIFICATIONS

	MODEL	DHS200A05	DHS200A12	DHS200A15	DHS200A24	
INPUT	VOLTAGE[V]	DC60 - 160				
	CURRENT[A]	2.1A	2.1A	2.1A	2.1A	
	EFFICIENCY[%]	87.0typ	88.0typ	88.0typ	88.0typ	
OUTPUT	VOLTAGE[V]	5	12	15	24	
	CURRENT[A]	40	16.7	13.4	8.4	
	LINE REGULATION[mV]	10max	24max	30max	48max	
	LOAD REGULATION[mV]	10max	24max	30max	48max	
	RIPPLE[mVp-p]	0 to +100°C *2	80max	120max	120max	120max
		-40 to 0°C *2	120max	150max	150max	150max
		0 to 15% Load *2	160max	240max	240max	240max
	RIPPLE NOISE[mVp-p]	0 to +100°C *2	120max	150max	150max	150max
		-40 to 0°C *2	200max	200max	200max	250max
		0 to 15% Load *2	240max	300max	300max	300max
	TEMPERATURE REGULATION[mV]	0 to +65°C	50max	120max	150max	240max
		-40 to +100°C	100max	240max	300max	480max
DRIFT[mV]	*3	20max	40max	60max	90max	
START-UP TIME[ms]	200max (DCIN 110V, Io=100%)					
OUTPUT VOLTAGE ADJUSTMENT RANGE[V]	*4	Fixed (TRM pin open), adjustable by external VR or external voltage				
		3.00 - 6.00	7.20 - 13.20	9.00 - 16.50	14.40 - 26.40	
OUTPUT VOLTAGE SETTING[V]		4.97 - 5.13	11.91 - 12.29	14.76 - 15.24	23.62 - 24.38	
PROTECTION CIRCUIT AND OTHERS	OVERCURRENT PROTECTION	Works over 105% of rating and recovers automatically				
	OVERVOLTAGE PROTECTION[V]	6.30 - 7.30	13.90 - 16.35	17.25 - 20.25	27.60 - 32.40	
	REMOTE SENSING	Provided				
	REMOTE ON/OFF	Provided (Negative Logic L : ON, H :OFF)				
ISOLATION	INPUT-OUTPUT	AC3,000V 1minute, Cutoff current = 10mA, DC500V 50MΩ min (20±15°C)				
	INPUT-FG	AC2,000V 1minute, Cutoff current = 10mA, DC500V 50MΩ min (20±15°C)				
	OUTPUT-FG	AC500V 1minute, Cutoff current = 100mA, DC500V 50MΩ min (20±15°C)				
ENVIRONMENT	OPERATING TEMP.,HUMID.AND ALTIITUDE	-40 to +100°C (On aluminum base plate), 20 - 95%RH (Non condensing) (Refer to DERATING CURVE), 3,000m (10,000 feet) max				
	STORAGE TEMP.,HUMID.AND ALTIITUDE	-40 to +100°C, 20 - 95%RH (Non condensing), 9,000m (30,000 feet) max				
	VIBRATION	10 - 55Hz, 49.0m/s <sup>2</sup> (5G), 3minutes period, 60minutes each along X, Y and Z axis Complies with IEC61373 Category 1 Class B				
	IMPACT	196.1m/s <sup>2</sup> (20G), 11ms, once each along X, Y and Z axis Complies with IEC61373 Category 1 Class B				
SAFETY	AGENCY APPROVALS	UL60950-1, C-UL (CSA60950-1), EN60950-1				
OTHERS	CASE SIZE/WEIGHT	58.4 × 12.7 × 61mm [2.3 × 0.5 × 2.4 inches] (W × H × D) / 100g max				
	COOLING METHOD	Conduction cooling (e.g. heat radiation from the aluminum base plate to the attached heat sink)				

\*1 At rated input(DC110V) and rated load.  
 \*2 Ripple and ripple noise is measured by using measuring board. Refer to the manual.  
 \*3 Drift is the change in DC output for an eight hour period after a half-hour warm-up at 25°C, with the input voltage held constant at the rated input/output.  
 \*4 Refer to the manual for input range.

External view

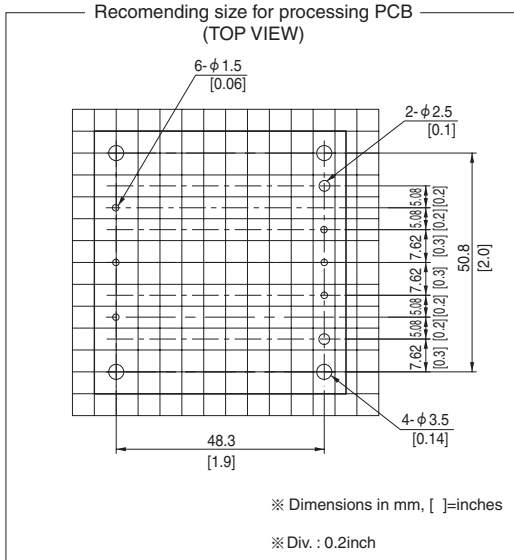
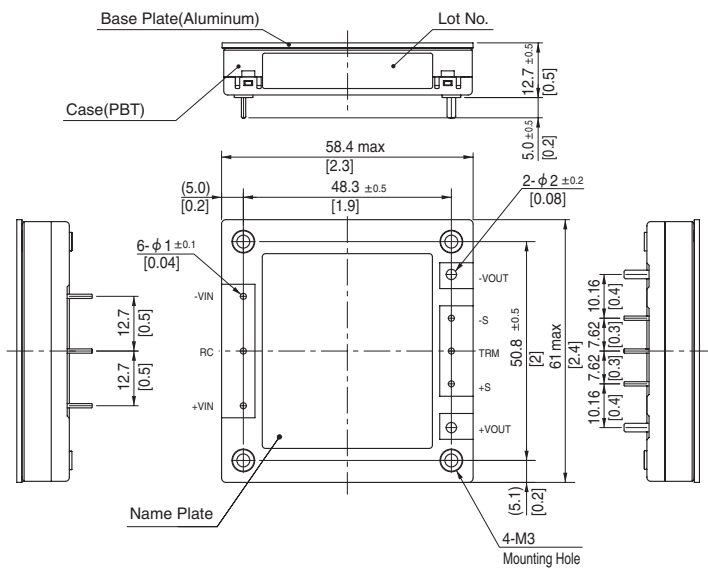

- ※ Dimensions in mm, [ ]=inches
- ※ Div. : 0.2inch
- ※ Tolerance : ±0.3 [±0.012]
- ※ Weight : 100g max
- ※ Dimensions in mm, [ ]=inches
- ※ Mounting hole screwing torque : 0.49N · m (5.0kgf · cm) max

# DHS50B

DH S 50 B 05 -□

① ② ③ ④ ⑤ ⑥



RoHS

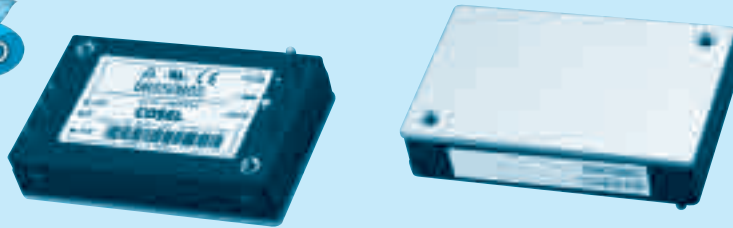

\*Providing heat sink as option

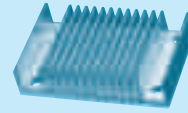

- ① Series name
- ② Single output
- ③ Output wattage
- ④ B : DC200-400V
- ⑤ Output voltage
- ⑥ Optional
- T : with Mounting hole (φ 3.4 thru)

MODEL	DHS50B03	DHS50B05	DHS50B12	DHS50B15	DHS50B24	DHS50B28
MAX OUTPUT WATTAGE[W]	33.0	50.0	50.4	51.0	50.4	50.4
DC OUTPUT	3.3V 10A	5V 10A	12V 4.2A	15V 3.4A	24V 2.1A	28V 1.8A

## SPECIFICATIONS

	MODEL	DHS50B03	DHS50B05	DHS50B12	DHS50B15	DHS50B24	DHS50B28	
INPUT	VOLTAGE[V]	DC200 - 400						
	CURRENT[A]	*1 0.15A	0.22A	0.22A	0.22A	0.22A	0.22A	
	EFFICIENCY[%]	*1 77.0typ	80.0typ	83.0typ	83.0typ	83.0typ	82.0typ	
OUTPUT	VOLTAGE[V]	3.3	5	12	15	24	28	
	CURRENT[A]	10	10	4.2	3.4	2.1	1.8	
	LINE REGULATION[mV]	10max	10max	24max	30max	48max	56max	
	LOAD REGULATION[mV]	10max	10max	24max	30max	48max	56max	
	RIPPLE[mVp-p]	0 to +100°C *2	80max	80max	120max	120max	120max	120max
		-40 to 0°C *2	120max	120max	150max	150max	150max	150max
		0 to 15% Load *2	160max	160max	240max	240max	240max	240max
	RIPPLE NOISE[mVp-p]	0 to +100°C *2	120max	120max	150max	150max	150max	150max
		-40 to 0°C *2	200max	200max	200max	200max	250max	250max
		0 to 15% Load *2	240max	240max	300max	300max	300max	300max
	TEMPERATURE REGULATION[mV]	0 to +65°C	35max	50max	120max	150max	240max	280max
		-40 to +100°C	66max	100max	240max	300max	480max	560max
	DRIFT[mV]	*3 16max	20max	40max	60max	90max	90max	
	START-UP TIME[ms]	200max (DCIN 280V, Io=100%)						
OUTPUT VOLTAGE ADJUSTMENT RANGE[V]	*4 Fixed (TRM pin open), adjustable by external VR or external voltage							
OUTPUT VOLTAGE SETTING[V]	3.30 - 3.40	4.50 - 5.13	10.80 - 13.20	13.50 - 16.50	21.60 - 26.40	25.20 - 30.80		
	3.30 - 3.40	4.97 - 5.13	11.91 - 12.29	14.76 - 15.24	23.62 - 24.38	27.56 - 28.44		
PROTECTION CIRCUIT AND OTHERS	OVERCURRENT PROTECTION	Works over 105% of rating and recovers automatically						
	OVERVOLTAGE PROTECTION[V]	4.20 - 5.70	6.30 - 7.60	13.90 - 17.55	17.25 - 21.75	27.60 - 34.80	32.20 - 40.60	
	REMOTE SENSING	None						
	REMOTE ON/OFF	Provided (Negative Logic L : ON, H : OFF)						
ISOLATION	INPUT-OUTPUT	AC3,000V 1minute, Cutoff current = 10mA, DC500V 50MΩ min (20±15°C)						
	INPUT-FG	AC2,000V 1minute, Cutoff current = 10mA, DC500V 50MΩ min (20±15°C)						
	OUTPUT-FG	AC500V 1minute, Cutoff current = 100mA, DC500V 50MΩ min (20±15°C)						
ENVIRONMENT	OPERATING TEMP., HUMID. AND ALTITUDE	-40 to +100°C (On aluminum base plate), 20 - 95%RH (Non condensing) (Refer to DERATING CURVE), 3,000m (10,000 feet) max						
	STORAGE TEMP., HUMID. AND ALTITUDE	-40 to +100°C, 20 - 95%RH (Non condensing), 9,000m (30,000 feet) max						
	VIBRATION	10 - 55Hz, 49.0m/s <sup>2</sup> (5G), 3minutes period, 60minutes each along X, Y and Z axis						
	IMPACT	196.1m/s <sup>2</sup> (20G), 11ms, once each along X, Y and Z axis						
SAFETY	AGENCY APPROVALS	UL60950-1, C-UL, EN60950-1						
OTHERS	CASE SIZE/WEIGHT	58.4 × 12.7 × 37.3mm [2.3 × 0.5 × 1.47 inches] (W × H × D) / 60g max						
	COOLING METHOD	Conduction cooling (e.g. heat radiation from the aluminum base plate to the attached heat sink)						

\*1 At rated input(DC280V) and rated load.  
 \*2 Ripple and ripple noise is measured by using measuring board. Refer to the manual  
 \*3 Drift is the change in DC output for an eight hour period after a half-hour warm-up at 25°C, with the input voltage held constant at the rated input/output.  
 \*4 Refer to the manual for input range.

External view

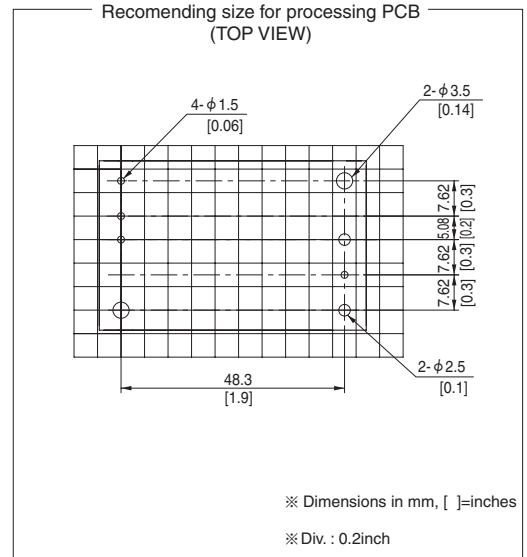
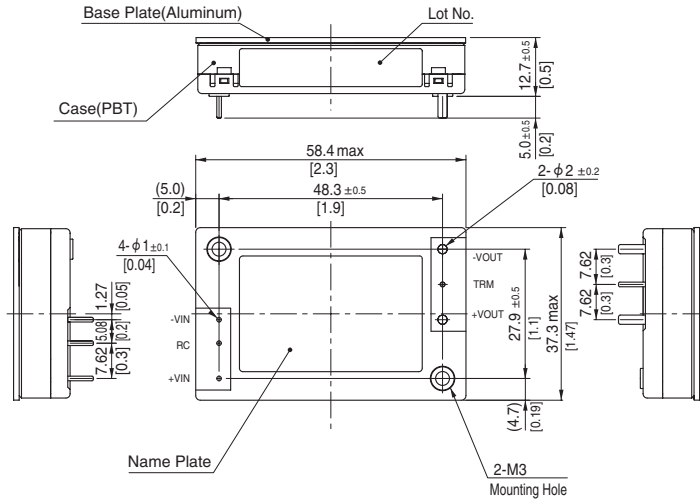

※ Dimensions in mm, [ ]=inches  
 ※ Div. : 0.2inch

- ※ Tolerance : ±0.3 [±0.012]
- ※ Weight : 60g max
- ※ Dimensions in mm, [ ]=inches
- ※ Mounting hole screwing torque : 0.49N · m (5.0kgf · cm) max



# DHS100B

DH S 100 B 05 -□

① ② ③ ④ ⑤ ⑥



RoHS

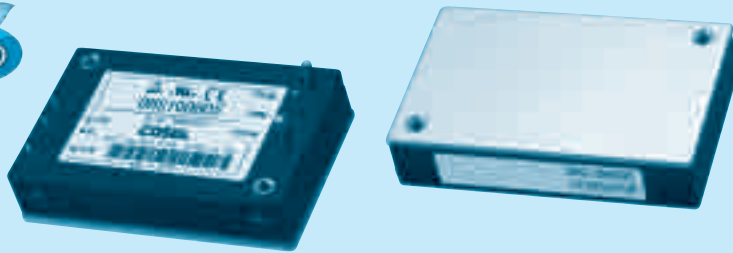

\*Providing heat sink as option

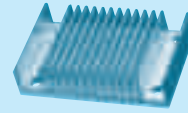

- ① Series name
- ② Single output
- ③ Output wattage
- ④ B : DC200-400V
- ⑤ Output voltage
- ⑥ Optional
- T : with Mounting hole (φ 3.4 thru)

MODEL	DHS100B03	DHS100B05	DHS100B12	DHS100B15	DHS100B24	DHS100B28
MAX OUTPUT WATTAGE[W]	66.0	100.0	100.8	100.5	100.8	100.8
DC OUTPUT	3.3V 20A	5V 20A	12V 8.4A	15V 6.7A	24V 4.2A	28V 3.6A

## SPECIFICATIONS

	MODEL	DHS100B03	DHS100B05	DHS100B12	DHS100B15	DHS100B24	DHS100B28	
INPUT	VOLTAGE[V]	DC200 - 400						
	CURRENT[A]	0.30A	0.44A	0.42A	0.42A	0.42A	0.42A	
	EFFICIENCY[%]	79.0typ	82.0typ	85.0typ	86.0typ	86.0typ	86.0typ	
		*1						
OUTPUT	VOLTAGE[V]	3.3	5	12	15	24	28	
	CURRENT[A]	20	20	8.4	6.7	4.2	3.6	
	LINE REGULATION[mV]	10max	10max	24max	30max	48max	56max	
	LOAD REGULATION[mV]	10max	10max	24max	30max	48max	56max	
	RIPPLE[mVp-p]	0 to +100°C *2	80max	80max	120max	120max	120max	120max
		-40 to 0°C *2	120max	120max	150max	150max	150max	150max
		0 to 15% Load *2	160max	160max	240max	240max	240max	240max
	RIPPLE NOISE[mVp-p]	0 to +100°C *2	120max	120max	150max	150max	150max	150max
		-40 to 0°C *2	200max	200max	200max	200max	250max	250max
		0 to 15% Load *2	240max	240max	300max	300max	300max	300max
	TEMPERATURE REGULATION[mV]	0 to +65°C	35max	50max	120max	150max	240max	280max
		-40 to +100°C	66max	100max	240max	300max	480max	560max
	DRIFT[mV]	*3	16max	20max	40max	60max	90max	90max
	START-UP TIME[ms]	200max (DCIN 280V, Io=100%)						
OUTPUT VOLTAGE ADJUSTMENT RANGE[V]	*4	Fixed (TRM pin open), adjustable by external VR or external voltage						
		2.97 - 3.96	4.50 - 6.00	10.80 - 13.20	13.50 - 16.50	21.60 - 26.40	25.20 - 30.80	
OUTPUT VOLTAGE SETTING[V]		3.30 - 3.40	4.97 - 5.13	11.91 - 12.29	14.76 - 15.24	23.62 - 24.38	27.56 - 28.44	
PROTECTION CIRCUIT AND OTHERS	OVERCURRENT PROTECTION	Works over 105% of rating and recovers automatically						
	OVERVOLTAGE PROTECTION[V]	4.20 - 5.70	6.30 - 7.60	13.90 - 17.55	17.25 - 21.75	27.60 - 34.80	32.20 - 40.60	
	REMOTE SENSING	None						
	REMOTE ON/OFF	Provided (Negative Logic L : ON, H : OFF)						
ISOLATION	INPUT-OUTPUT	AC3,000V 1minute, Cutoff current = 10mA, DC500V 50MΩ min (20±15°C)						
	INPUT-FG	AC2,000V 1minute, Cutoff current = 10mA, DC500V 50MΩ min (20±15°C)						
	OUTPUT-FG	AC500V 1minute, Cutoff current = 100mA, DC500V 50MΩ min (20±15°C)						
ENVIRONMENT	OPERATING TEMP., HUMID. AND ALTITUDE	-40 to +100°C (On aluminum base plate), 20 - 95%RH (Non condensing) (Refer to DERATING CURVE), 3,000m (10,000 feet) max						
	STORAGE TEMP., HUMID. AND ALTITUDE	-40 to +100°C, 20 - 95%RH (Non condensing), 9,000m (30,000 feet) max						
	VIBRATION	10 - 55Hz, 49.0m/s <sup>2</sup> (5G), 3minutes period, 60minutes each along X, Y and Z axis						
	IMPACT	196.1m/s <sup>2</sup> (20G), 11ms, once each along X, Y and Z axis						
SAFETY	AGENCY APPROVALS	UL60950-1, C-UL, EN60950-1						
OTHERS	CASE SIZE/WEIGHT	58.4 X 12.7 X 37.3mm [2.3 X 0.5 X 1.47 inches] (W X H X D) / 60g max						
	COOLING METHOD	Conduction cooling (e.g. heat radiation from the aluminum base plate to the attached heat sink)						

\*1 At rated input(DC280V) and rated load.  
 \*2 Ripple and ripple noise is measured by using measuring board. Refer to the manual.  
 \*3 Drift is the change in DC output for an eight hour period after a half-hour warm-up at 25°C, with the input voltage held constant at the rated input/output.  
 \*4 Refer to the manual for input range.

External view



- ※ Tolerance : ±0.3 [±0.012]
- ※ Weight : 60g max
- ※ Dimensions in mm, [ ]=inches
- ※ Mounting hole screwing torque : 0.49N · m (5.0kgf · cm) max

# DHS250B

DH S 250 B 05 -□

① ② ③ ④ ⑤ ⑥

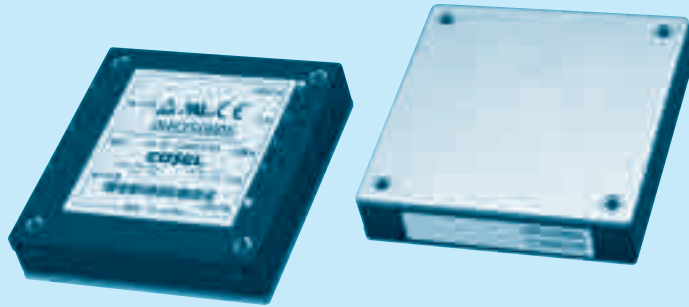

\*Providing heat sink as option

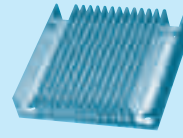

- ① Series name
- ② Single output
- ③ Output wattage
- ④ B : DC200-400V
- ⑤ Output voltage
- ⑥ Optional
- T : with Mounting hole (φ 3.4 thru)

MODEL	DHS250B03	DHS250B05	DHS250B07	DHS250B12	DHS250B15	DHS250B24	DHS250B28	DHS250B48
MAX OUTPUT WATTAGE[W]	165.0	250.0	247.5	252.0	247.5	252.0	252.0	249.6
DC OUTPUT	3.3V 50A	5V 50A	7.5V 33A	12V 21A	15V 16.5A	24V 10.5A	28V 9.0A	48V 5.2A

## SPECIFICATIONS

	MODEL	DHS250B03	DHS250B05	DHS250B07	DHS250B12	DHS250B15	DHS250B24	DHS250B28	DHS250B48	
INPUT	VOLTAGE[V]	DC200 - 400								
	CURRENT[A]	*1 0.67A	1.0A	1.0A	1.0A	1.0A	1.0A	1.0A	1.0A	
	EFFICIENCY[%]	*1 88.0typ	90.0typ	88.0typ	88.0typ	88.0typ	88.0typ	88.0typ	89.0typ	
OUTPUT	VOLTAGE[V]	3.3	5	7.5	12	15	24	28	48	
	CURRENT[A]	50	50	33	21	16.5	10.5	9.0	5.2	
	LINE REGULATION[mV]	10max	10max	20max	24max	30max	48max	56max	96max	
	LOAD REGULATION[mV]	10max	10max	20max	24max	30max	48max	56max	96max	
	RIPPLE[mVp-p]	0 to +100°C *2	80max	80max	100max	120max	120max	120max	120max	200max
		-40 to 0°C *2	120max	120max	130max	150max	150max	150max	150max	250max
		0 to 15% Load *2	160max	160max	200max	240max	240max	240max	240max	400max
	RIPPLE NOISE[mVp-p]	0 to +100°C *2	120max	120max	130max	150max	150max	150max	150max	250max
		-40 to 0°C *2	200max	200max	200max	200max	200max	250max	250max	400max
		0 to 15% Load *2	240max	240max	260max	300max	300max	300max	300max	500max
	TEMPERATURE REGULATION[mV]	0 to +65°C	35max	50max	70max	120max	150max	240max	280max	480max
-40 to +100°C		66max	100max	140max	240max	300max	480max	560max	960max	
DRIFT[mV]	*3	16max	20max	30max	40max	60max	90max	90max	180max	
START-UP TIME[ms]		200max (DCIN 280V, Io=100%)								
OUTPUT VOLTAGE ADJUSTMENT RANGE[V]	*4	Fixed (TRM pin open), adjustable by external VR or external voltage								
		1.98 - 3.96	3.00 - 6.00	4.50 - 8.25	7.20 - 13.20	9.00 - 16.50	14.40 - 26.40	16.80 - 30.80	28.80 - 52.80	
OUTPUT VOLTAGE SETTING[V]		3.30 - 3.40	4.97 - 5.13	7.43 - 7.67	11.91 - 12.29	14.76 - 15.24	23.62 - 24.38	27.56 - 28.44	47.24 - 48.76	
PROTECTION CIRCUIT AND OTHERS	OVERCURRENT PROTECTION	Works over 105% of rating and recovers automatically								
	OVERVOLTAGE PROTECTION[V]	4.20 - 4.85	6.30 - 7.30	8.70 - 10.20	13.90 - 16.35	17.25 - 20.25	27.60 - 32.40	32.20 - 37.80	55.20 - 64.80	
	REMOTE SENSING	Provided								
REMOTE ON/OFF	Provided (Negative Logic L : ON, H : OFF)									
ISOLATION	INPUT-OUTPUT	AC3,000V 1minute, Cutoff current = 10mA, DC500V 50MΩ min (20±15°C)								
	INPUT-FG	AC2,000V 1minute, Cutoff current = 10mA, DC500V 50MΩ min (20±15°C)								
	OUTPUT-FG	AC500V 1minute, Cutoff current = 100mA, DC500V 50MΩ min (20±15°C)								
ENVIRONMENT	OPERATING TEMP., HUMID. AND ALTITUDE	-40 to +100°C (On aluminum base plate), 20 - 95%RH (Non condensing) (Refer to DERATING CURVE), 3,000m (10,000 feet) max								
	STORAGE TEMP., HUMID. AND ALTITUDE	-40 to +100°C, 20 - 95%RH (Non condensing), 9,000m (30,000 feet) max								
	VIBRATION	10 - 55Hz, 49.0m/s <sup>2</sup> (5G), 3minutes period, 60minutes each along X, Y and Z axis								
	IMPACT	196.1m/s <sup>2</sup> (20G), 11ms, once each along X, Y and Z axis								
SAFETY	AGENCY APPROVALS	UL60950-1, C-UL, EN60950-1								
OTHERS	CASE SIZE/WEIGHT	58.4 × 12.7 × 61mm [2.3 × 0.5 × 2.4 inches](W × H × D) / 100g max								
	COOLING METHOD	Conduction cooling (e.g. heat radiation from the aluminum base plate to the attached heat sink)								

\*1 At rated input(DC280V) and rated load.  
 \*2 Ripple and ripple noise is measured by using measuring board. Refer to the manual.  
 \*3 Drift is the change in DC output for an eight hour period after a half-hour warm-up at 25°C, with the input voltage held constant at the rated input/output.  
 \*4 Refer to the manual for input range.

External view

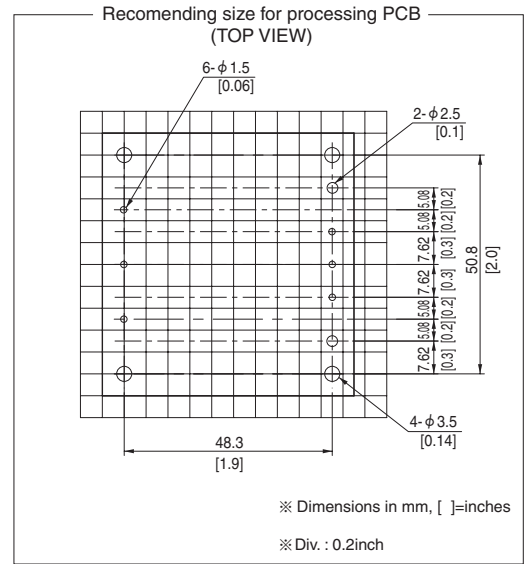
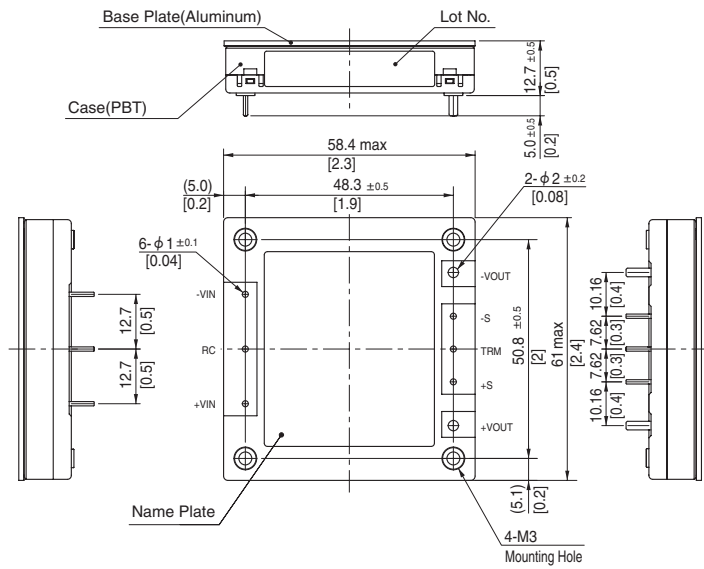

※ Dimensions in mm, [ ]=inches  
 ※ Div. : 0.2inch

- ※ Tolerance :  $\pm 0.3$  [ $\pm 0.012$ ]
- ※ Weight : 100g max
- ※ Dimensions in mm, [ ]=inches
- ※ Mounting hole screwing torque :  $0.49\text{N} \cdot \text{m}$  (5.0kgf · cm) max