



12-Bit, Parallel Input, Multiplying Digital-to-Analog Converter

FEATURES

- 2.5 V to 5.5 V Supply Operation
- Fast Parallel Interface:
17ns Write Cycle
- Update Rate of 20.4 MSPS
- 10 MHz Multiplying Bandwidth
- ± 10 V Reference Input
- Low Glitch Energy: 5 nV-s
- Extended Temperature Range:
 -40°C to $+125^{\circ}\text{C}$
- 20-Lead QFN and 20-Lead TSSOP Packages
- 12-Bit Monotonic
- ± 1 LSB INL
- 4-Quadrant Multiplication
- Power-On Reset with Brownout Detection
- Readback Function
- Industry-Standard Pin Configuration

APPLICATIONS

- Portable Battery-Powered Instruments
- Waveform Generators
- Analog Processing
- Programmable Amplifiers and Attenuators
- Digitally-Controlled Calibration
- Programmable Filters and Oscillators
- Composite Video
- Ultrasound

DESCRIPTION

The DAC7821 is a CMOS 12-bit current output digital-to-analog converter (DAC). This device operates from a single 2.5 V to 5.5 V power supply, making it suitable to battery-powered and many other applications.

This DAC operates with a fast parallel interface. Data readback allows the user to read the contents of the DAC register via the DB pins. On power-up, the internal register and latches are filled with zeroes and the DAC outputs are at zero scale.

The DAC7821 offers excellent 4-quadrant multiplication characteristics, with large signal multiplying bandwidth of 10 MHz. The applied external reference input voltage (V_{REF}) determines the full-scale output current. An integrated feedback resistor (R_{FB}) provides temperature tracking and full-scale voltage output when combined with an external current-to-voltage precision amplifier.

The DAC7821 is available in a 20-lead TSSOP package as well as a small 20-lead QFN package (available Q2 2006).

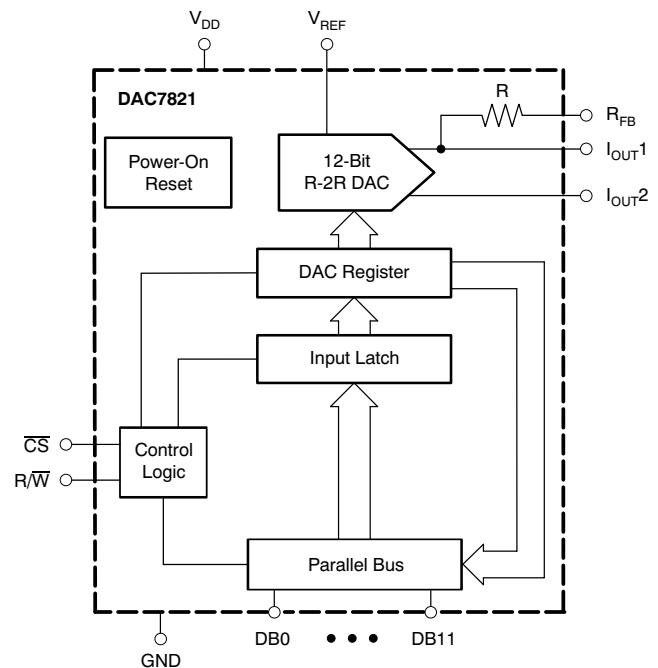

Please be aware that an important notice concerning availability, standard warranty, and use in critical applications of Texas Instruments semiconductor products and disclaimers thereto appears at the end of this data sheet.

All trademarks are the property of their respective owners.



This integrated circuit can be damaged by ESD. Texas Instruments recommends that all integrated circuits be handled with appropriate precautions. Failure to observe proper handling and installation procedures can cause damage.

ESD damage can range from subtle performance degradation to complete device failure. Precision integrated circuits may be more susceptible to damage because very small parametric changes could cause the device not to meet its published specifications.

ORDERING INFORMATION⁽¹⁾

PRODUCT	PACKAGE	PACKAGE DESIGNATOR	SPECIFIED TEMPERATURE RANGE	PACKAGE MARKING	ORDERING NUMBER	TRANSPORT MEDIA, QUANTITY
DAC7821	20-TSSOP	PW	–40°C to +125°C	DAC7821	DAC7821IPW	70, Tube
					DAC7821IPWR	2000, Tape and Reel
DAC7821	20-QFN ⁽²⁾	RGP	–40°C to +125°C	DAC7821	DAC7821IRGPT	250, Tape and Reel
					DAC7821IRGPR	3000, Tape and Reel

(1) For the most current specifications and package information, see the Package Option Addendum located at the end of this data sheet or refer to our web site at www.ti.com.

(2) Available 2Q 2006.

ABSOLUTE MAXIMUM RATINGS

over operating free-air temperature range (unless otherwise noted)⁽¹⁾

	DAC7821	UNIT
V _{DD} to GND	–0.3 to +7.0	V
Digital input voltage to GND	–0.3 to V _{DD} + 0.3	V
V _{OUT} to GND	–0.3 to V _{DD} + 0.3	V
Operating temperature range	–40 to +125	°C
Storage temperature range	–65 to +150	°C
Junction temperature (T _J max)	+150	°C
ESD Rating, HBM	3000	V
ESD Rating, CDM	1000	V

(1) Stresses above those listed under absolute maximum ratings may cause permanent damage to the device. Exposure to absolute maximum conditions for extended periods may affect device reliability.

ELECTRICAL CHARACTERISTICS

$V_{DD} = +2.5\text{ V to }+5.5\text{ V}$; $I_{OUT1} = \text{Virtual GND}$; $I_{OUT2} = 0\text{ V}$; $V_{REF} = +10\text{ V}$; $T_A = \text{full operating temperature}$. All specifications $-40^\circ\text{C to }+125^\circ\text{C}$, unless otherwise noted.

PARAMETER	CONDITIONS	DAC7821			UNITS
		MIN	TYP	MAX	
STATIC PERFORMANCE					
Resolution		12			Bits
Relative accuracy				± 1	LSB
Differential nonlinearity				± 1	LSB
Output leakage current	Data = 000h, $T_A = +25^\circ\text{C}$			± 10	nA
Output leakage current	Data = 000h, $T_A = T_{MAX}$			± 20	nA
Full-scale gain error	All ones loaded to DAC register		± 5	± 10	mV
Full-scale tempco			± 5		ppm/ $^\circ\text{C}$
Output capacitance	Code dependent		30		pF
REFERENCE INPUT					
V_{REF} range		-15		15	V
Input resistance		8	10	12	k Ω
R_{FB} resistance		8	10	12	k Ω
LOGIC INPUTS AND OUTPUT⁽¹⁾					
Input low voltage	V_{IL} $V_{DD} = +2.7\text{ V}$			0.6	V
	V_{IL} $V_{DD} = +5\text{ V}$			0.8	V
Input high voltage	V_{IH} $V_{DD} = +2.7\text{ V}$	2.1			V
	V_{IH} $V_{DD} = +5\text{ V}$	2.4			V
Input leakage current	I_{IL}			10	μA
Input capacitance	C_{IL}			10	pF
POWER REQUIREMENTS					
V_{DD}		2.7		5.5	V
I_{DD} (normal operation)	Logic inputs = 0 V			5	μA
$V_{DD} = +4.5\text{ V to }+5.5\text{ V}$	$V_{IH} = V_{DD}$ and $V_{IL} = \text{GND}$		0.8	5	μA
$V_{DD} = +2.5\text{ V to }+3.6\text{ V}$	$V_{IH} = V_{DD}$ and $V_{IL} = \text{GND}$		0.4	2.5	μA
AC CHARACTERISTICS					
Output voltage settling time				0.2	μs
Reference multiplying BW	$V_{REF} = 7 V_{PP}$, Data = FFFh		10		MHz
DAC glitch impulse	$V_{REF} = 0\text{ V to }10\text{ V}$, Data = 7FFh to 800h to 7FFh		5		nV-s
Feedthrough error V_{OUT}/V_{REF}	Data = 000h, $V_{REF} = 100\text{ kHz}$		-70		dB
Digital feedthrough			2		nV-s
Total harmonic distortion			-105		dB
Output spot noise voltage			18		nV/ $\sqrt{\text{Hz}}$

(1) Specified by design and characterization; not production tested.

TIMING INFORMATION

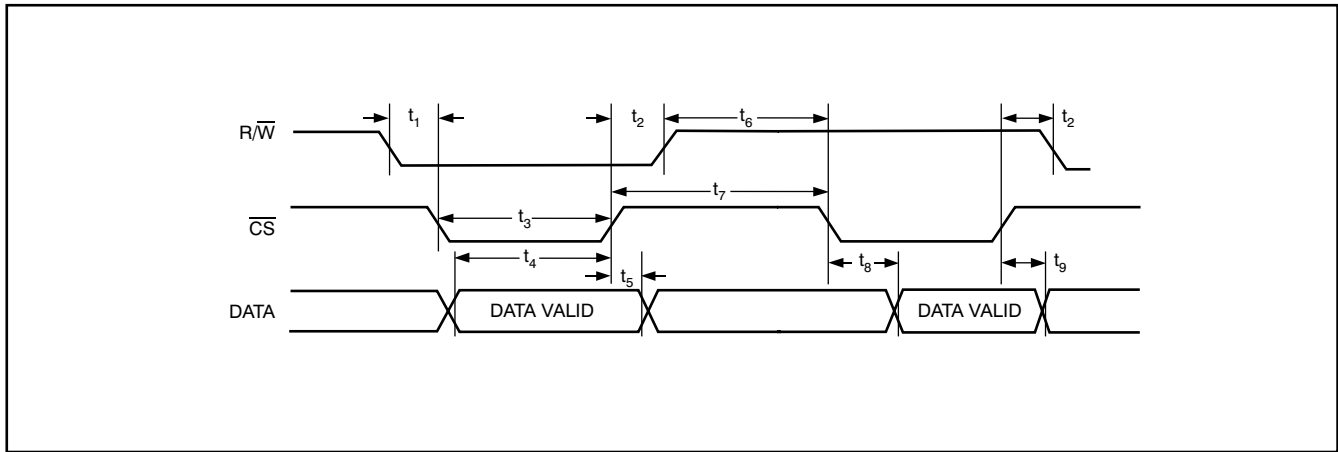

TIMING REQUIREMENTS: 2.5 V to 4.5 V

At $t_r = t_f = 1$ ns (10% to 90% of V_{DD}) and timed from a voltage level of $(V_{IL} + V_{IH})/2$; $V_{DD} = +2.5$ V to $+4.5$ V, $V_{REF} = +10$ V, $I_{OUT2} = 0$ V. All specifications -40°C to $+125^{\circ}\text{C}$, unless otherwise noted.

PARAMETER ⁽¹⁾	TEST CONDITIONS	DAC7821			UNIT
		MIN	TYP	MAX	
t_1	R/W to CS setup time	0			ns
t_2	R/W to CS hold time	0			ns
t_3	CS low time (write cycle)	10			ns
t_4	Data setup time	6			ns
t_5	Data hold time	0			ns
t_6	R/W high to CS low	5			ns
t_7	CS min high time	9			ns
t_8	Data access time		20	40	ns
t_9	Bus relinquish time		5	10	ns

(1) Ensured by design; not production tested.

TIMING REQUIREMENTS: 4.5 V to 5.5 V

At $t_r = t_f = 1$ ns (10% to 90% of V_{DD}) and timed from a voltage level of $(V_{IL} + V_{IH})/2$; $V_{DD} = +4.5$ V to $+5.5$ V, $V_{REF} = +10$ V, $I_{OUT2} = 0$ V. All specifications -40°C to $+125^{\circ}\text{C}$, unless otherwise noted.

PARAMETER ⁽¹⁾	TEST CONDITIONS	DAC7821			UNIT
		MIN	TYP	MAX	
t_1	R/W to CS setup time	0			ns
t_2	R/W to CS hold time	0			ns
t_3	CS low time (write cycle)	10			ns
t_4	Data setup time	6			ns
t_5	Data hold time	0			ns
t_6	R/W high to CS low	5			ns
t_7	CS min high time	7			ns
t_8	Data access time		10	20	ns
t_9	Bus relinquish time		5	10	ns

(1) Ensured by design; not production tested.

DEVICE INFORMATION

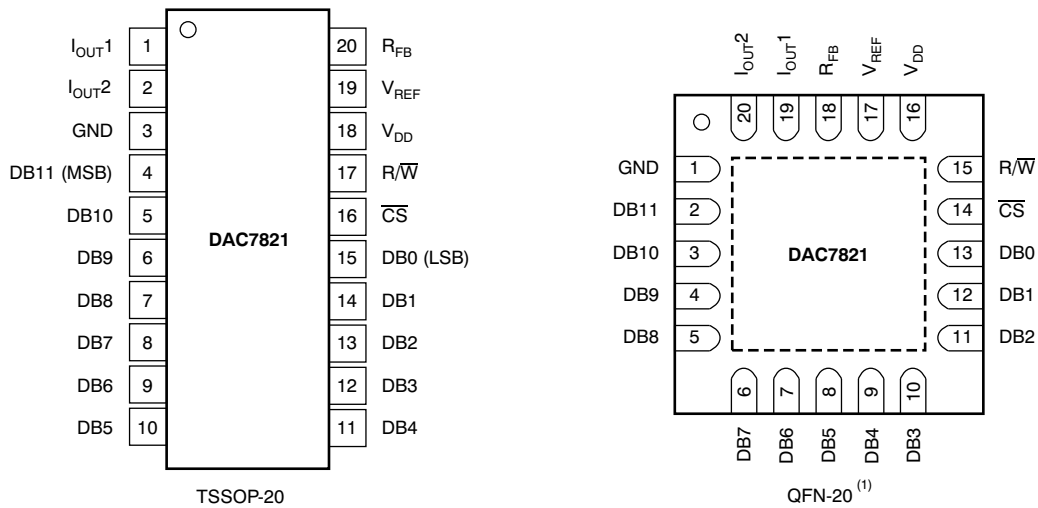

(1) QFN-20 package available 2Q 2006.

TERMINAL FUNCTIONS

TERMINAL		NAME	DESCRIPTION
TSSOP NO.	QFN NO.		
1	19	I_{OUT1}	DAC current output.
2	20	I_{OUT2}	DAC analog ground. This pin is normally tied to the analog ground of the system.
3	1	GND	Ground pin.
4–15	2–13	DB11 – DB0	Parallel data bits 11 to 0.
16	14	\overline{CS}	Chip select input. Active low. Used in conjunction with R/\overline{W} to load parallel data to the input latch or read data from the DAC register. Rising edge of \overline{CS} loads data.
17	15	R/\overline{W}	Read/Write. When low, use in conjunction with \overline{CS} to load parallel data. When high, use with \overline{CS} to read back contents of DAC register.
18	16	V_{DD}	Positive power supply input. These parts can be operated from a supply of 2.5 V to 5.5 V.
19	17	V_{REF}	DAC reference voltage input.
20	18	R_{FB}	DAC feedback resistor pin. Establish voltage output for the DAC by connecting to external amplifier output.

TYPICAL CHARACTERISTICS: $V_{DD} = +5\text{ V}$

At $T_A = +25^\circ\text{C}$, unless otherwise noted.

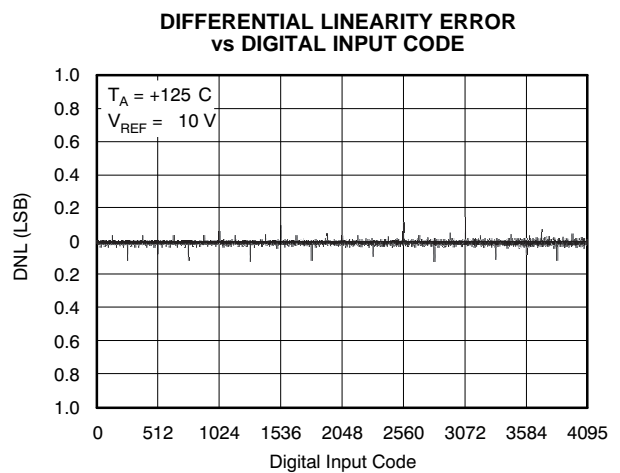
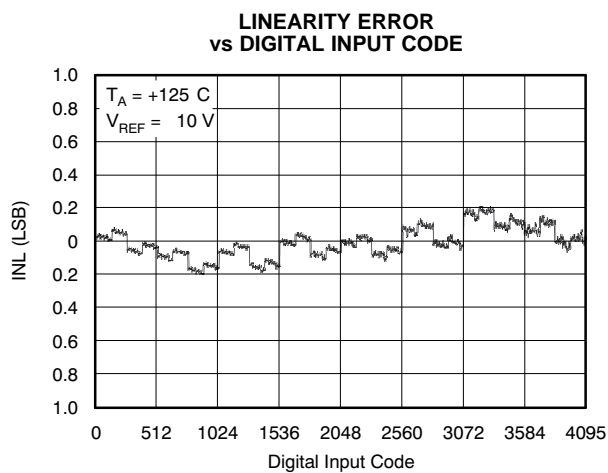
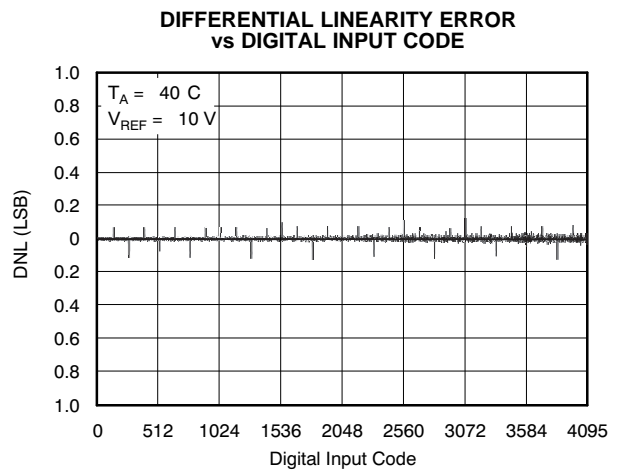
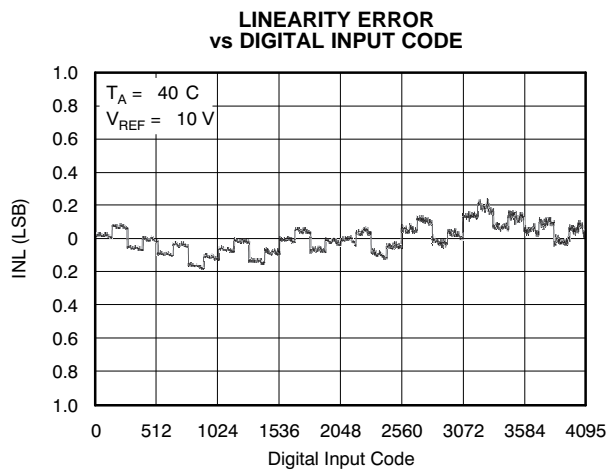
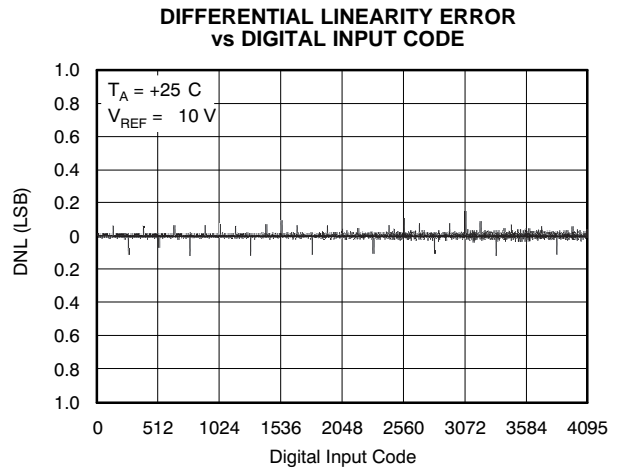
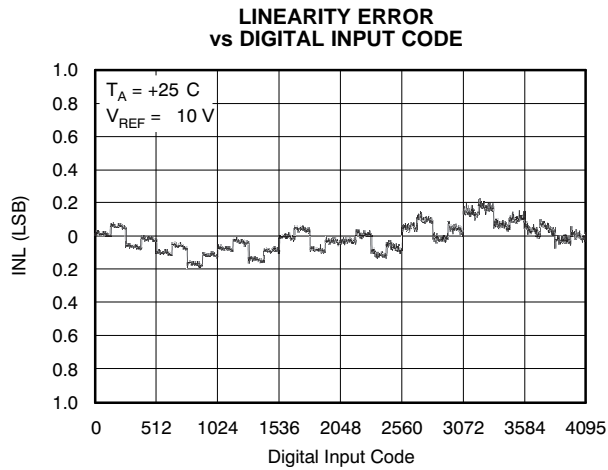

TYPICAL CHARACTERISTICS: $V_{DD} = +5\text{ V}$ (continued)

At $T_A = +25^\circ\text{C}$, unless otherwise noted.

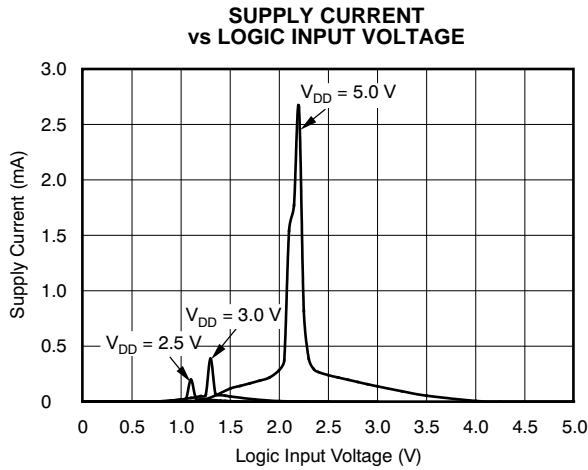

Figure 7.

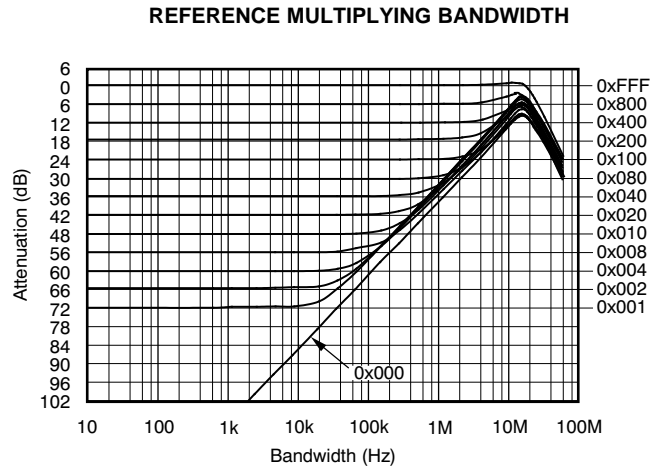

Figure 8.

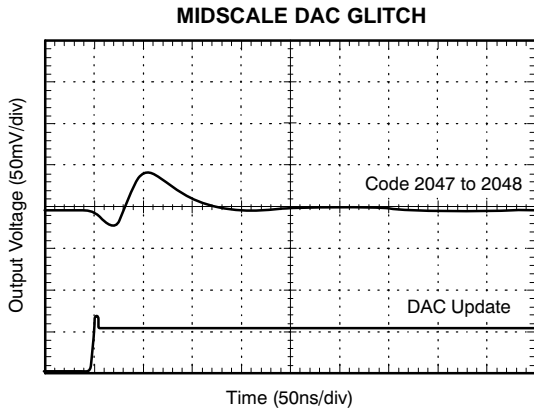

Figure 9.

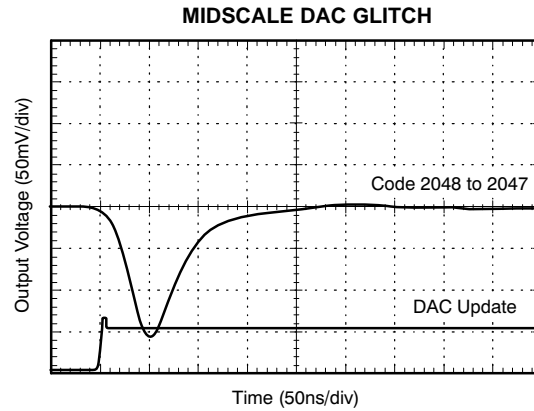

Figure 10.

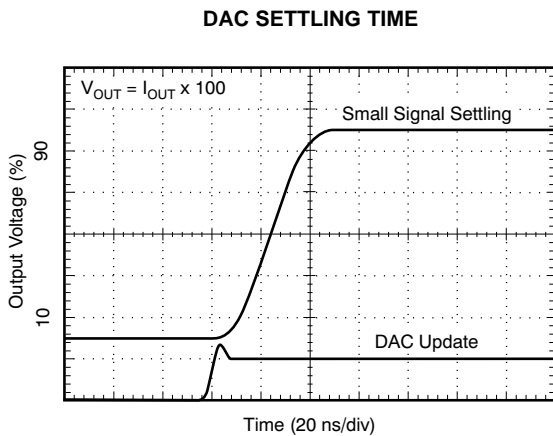

Figure 11.

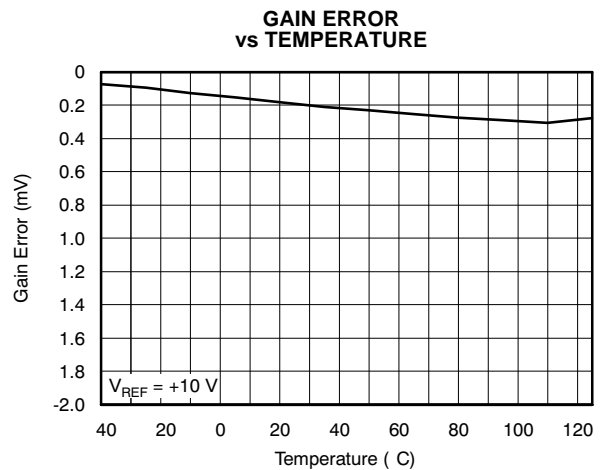

Figure 12.

TYPICAL CHARACTERISTICS: $V_{DD} = +5\text{ V}$ (continued)

At $T_A = +25^\circ\text{C}$, unless otherwise noted.

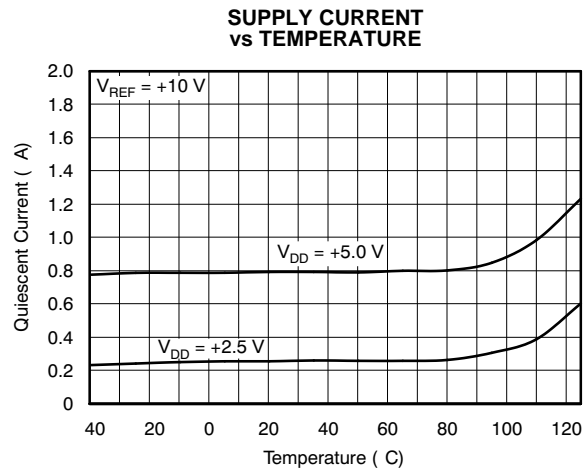

Figure 13.

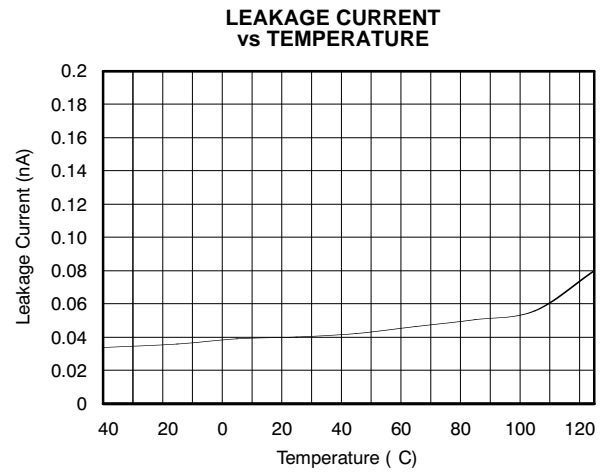

Figure 14.

TYPICAL CHARACTERISTICS: $V_{DD} = +2.5\text{ V}$

At $T_A = +25^\circ\text{C}$, unless otherwise noted.

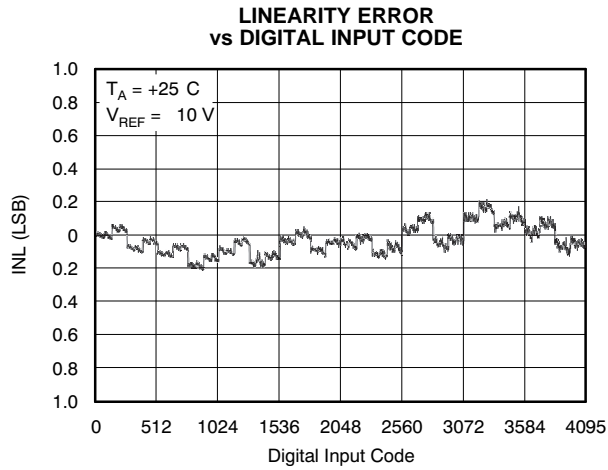

Figure 15.

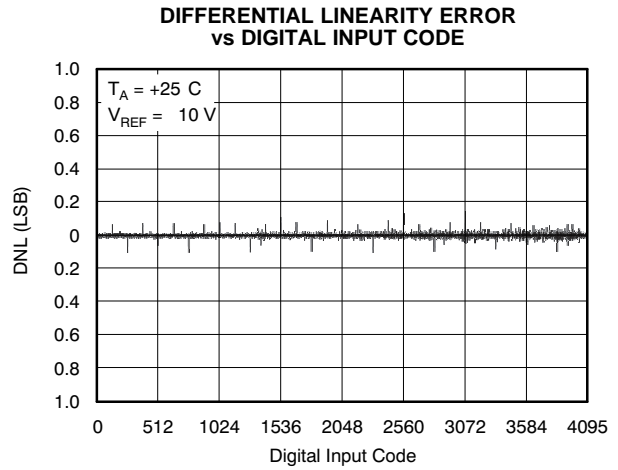

Figure 16.

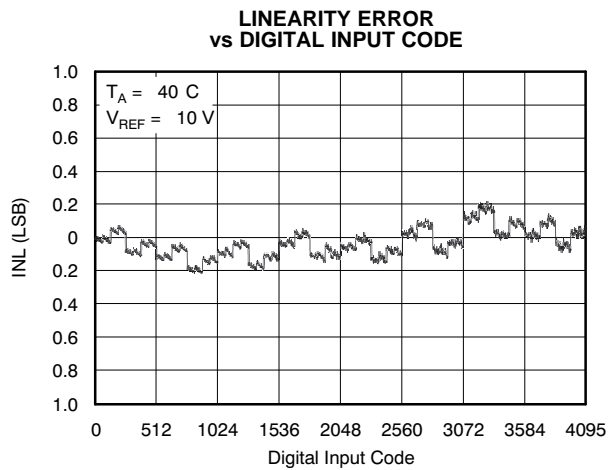

Figure 17.

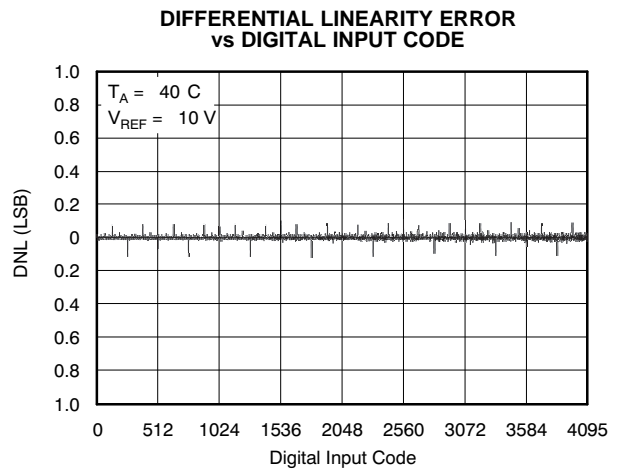

Figure 18.

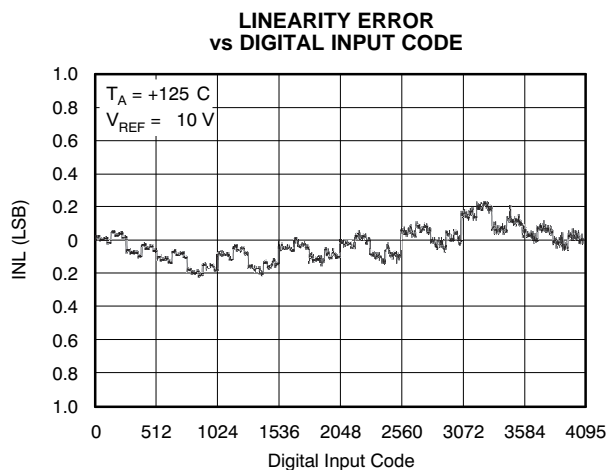

Figure 19.

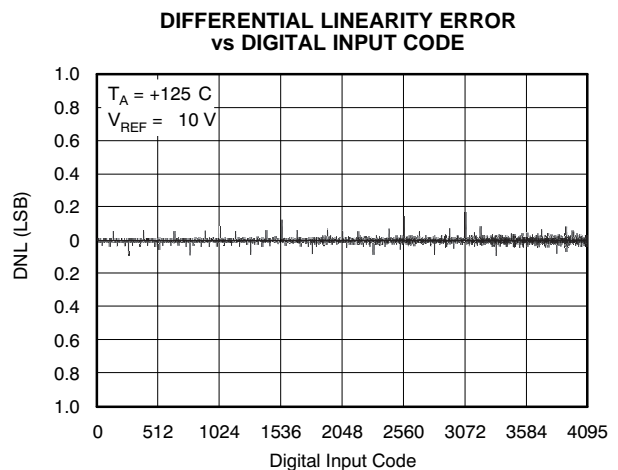

Figure 20.

TYPICAL CHARACTERISTICS: $V_{DD} = +2.5\text{ V}$ (continued)

At $T_A = +25^\circ\text{C}$, unless otherwise noted.

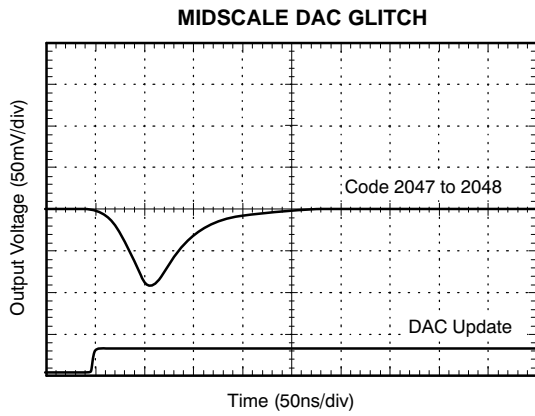

Figure 21.

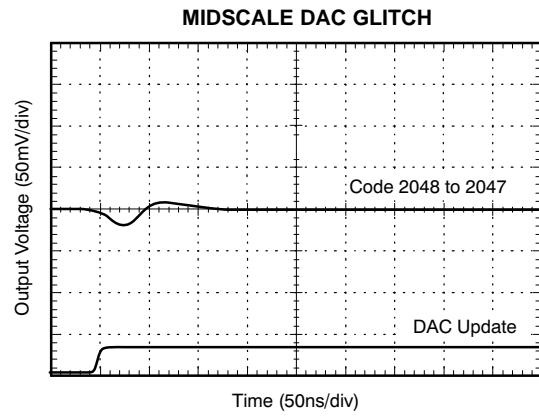

Figure 22.

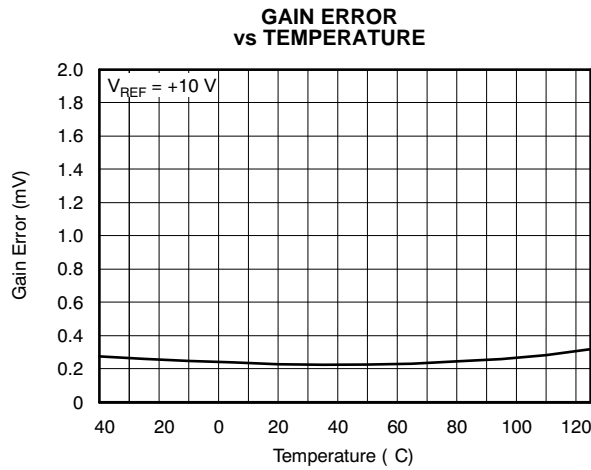

Figure 23.

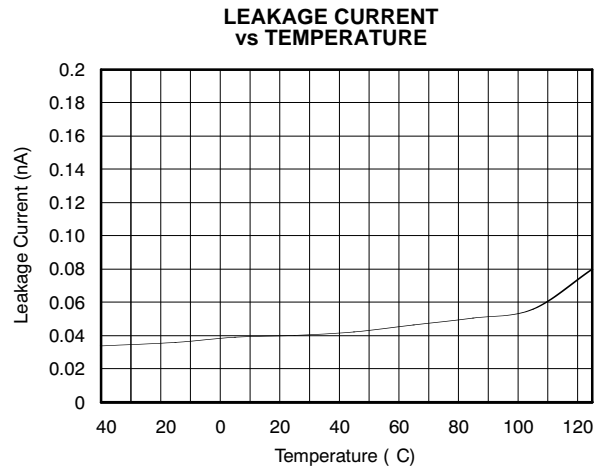

Figure 24.

THEORY OF OPERATION

The DAC7821 is a single channel current output, 12-bit digital-to-analog converter (DAC). The architecture, illustrated in Figure 25, is an R-2R ladder configuration with the three MSBs segmented. Each 2R leg of the ladder is either switched to I_{OUT1} or the I_{OUT2} terminal. The I_{OUT1} terminal of the DAC is held at a virtual GND potential by the use of an external I/V converter op amp. The R-2R ladder is connected to an external reference input V_{REF} that determines the DAC full-scale current. The R-2R ladder presents a code-independent load impedance to the external reference of 10 kΩ ±20%. The external reference voltage can vary over a range of –15 V to +15 V, thus providing bipolar I_{OUT} current operation. By using an external I/V converter and the DAC7821 R_{FB} resistor, output voltage ranges of –V_{REF} to V_{REF} can be generated.

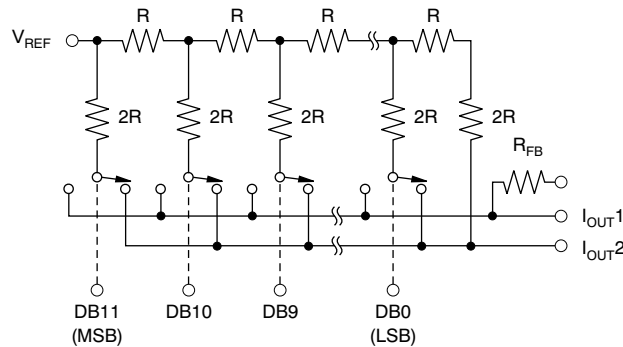

Figure 25. Equivalent R-2R DAC Circuit

When using an external I/V converter and the DAC7821 R_{FB} resistor, the DAC output voltage is given by Equation 1:

$$V_{OUT} = + V_{REF} \times \frac{CODE}{4096} \quad (1)$$

Each DAC code determines the 2R leg switch position to either GND or I_{OUT1}. Because the DAC output impedance as seen looking into the I_{OUT1} terminal changes versus code, the external I/V converter noise gain will also change. Because of this, the external I/V converter op amp must have a sufficiently low offset voltage such that the amplifier offset is not modulated by the DAC I_{OUT1} terminal impedance change. External op amps with large offset voltages can produce INL errors in the transfer function of the DAC7821 as a result of offset modulation versus DAC code.

For best linearity performance of the DAC7821, an op amp with a low input offset voltage (OPA277) is recommended (see Figure 26). This circuit allows V_{REF} swinging from –10 V to +10 V.

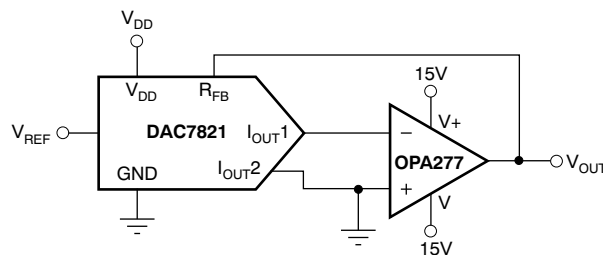

Figure 26. Voltage Output Configuration

APPLICATION INFORMATION

Stability Circuit

For a current-to-voltage design (see Figure 27), the DAC7821 current output (I_{OUT}) and the connection with the inverting node of the op amp should be as short as possible and according to correct printed circuit board (PCB) layout design. For each code change, there is a step function. If the gain bandwidth product (GBP) of the op amp is limited and parasitic capacitance is excessive at the inverting node, then gain peaking is possible. Therefore, for circuit stability, a compensation capacitor C_1 (1 pF to 5 pF typ) can be added to the design, as shown in Figure 27.

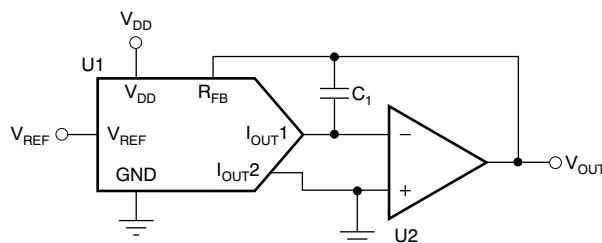

Figure 27. Gain Peaking Prevention Circuit with Compensation Capacitor

Positive Voltage Output Circuit

As Figure 28 illustrates, in order to generate a positive voltage output, a negative reference is input to the DAC7821. This design is suggested instead of using an inverting amp to invert the output as a result of resistor tolerance errors. For a negative reference, V_{OUT} and GND of the reference are level-shifted to a virtual ground and a -2.5 V input to the DAC7821 with an op amp.

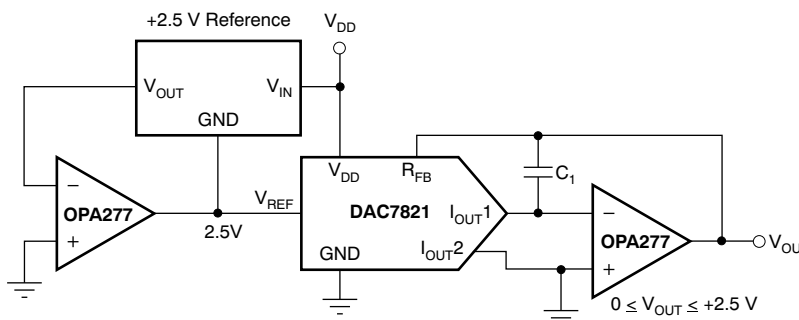

Figure 28. Positive Voltage Output Circuit

Bipolar Output Section

The DAC7821, as a 2-quadrant multiplying DAC, can be used to generate a unipolar output. The polarity of the full-scale output I_{OUT} is the inverse of the input reference voltage at V_{REF} .

Some applications require full 4-quadrant multiplying capabilities or bipolar output swing. As shown in Figure 29, external op amp U4 is added as a summing amp and has a gain of 2X that widens the output span to 5 V. A 4-quadrant multiplying circuit is implemented by using a 2.5 V offset of the reference voltage to bias U4. According to the circuit transfer equation given in Equation 2, input data (D) from code 0 to full-scale produces output voltages of $V_{OUT} = -2.5$ V to $V_{OUT} = +2.5$ V.

$$V_{OUT} = \left(\frac{D}{0.5 \times 2^N} + 1 \right) \times V_{REF} \tag{2}$$

APPLICATION INFORMATION (continued)

External resistance mismatching is the significant error in [Figure 29](#).

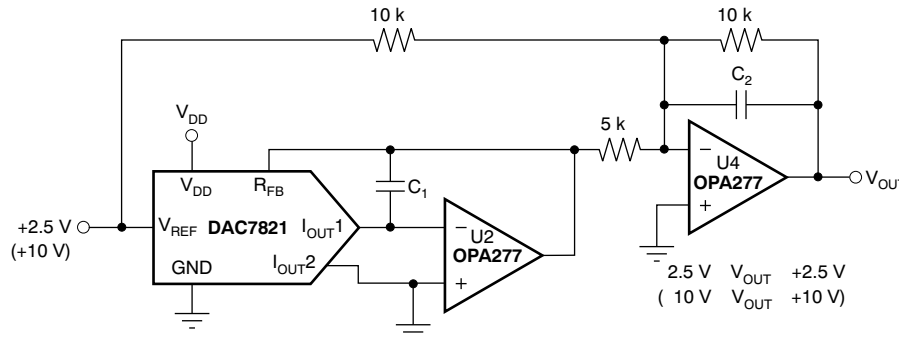

Figure 29. Bipolar Output Circuit

Programmable Current Source Circuit

A DAC7821 can be integrated into the circuit in [Figure 30](#) to implement an improved Howland current pump for precise voltage-to-current conversions. Bidirectional current flow and high voltage compliance are two features of the circuit. With a matched resistor network, the load current of the circuit is shown by [Equation 3](#):

$$I_L = \frac{(R2 + R3)' R1}{R3} \times V_{REF} \times D \tag{3}$$

The value of R3 in the previous equation can be reduced to increase the output current drive of U3. U3 can drive ±20 mA in both directions with voltage compliance limited up to 15 V by the U3 voltage supply. Elimination of the circuit compensation capacitor C1 in the circuit is not suggested as a result of the change in the output impedance Z_O, according to [Equation 4](#):

$$Z_O = \frac{R1'R3(R1 \times R2)}{R1(R2' \times R3') + R1'(R2 \times R3)} \tag{4}$$

As shown in [Equation 4](#), with matched resistors, Z_O is infinite and the circuit is optimum for use as a current source. However, if unmatched resistors are used, Z_O is positive or negative with negative output impedance being a potential cause of oscillation. Therefore, by incorporating C₁ into the circuit, possible oscillation problems are eliminated. The value of C₁ can be determined for critical applications; for most applications, however, a value of several pF is suggested.

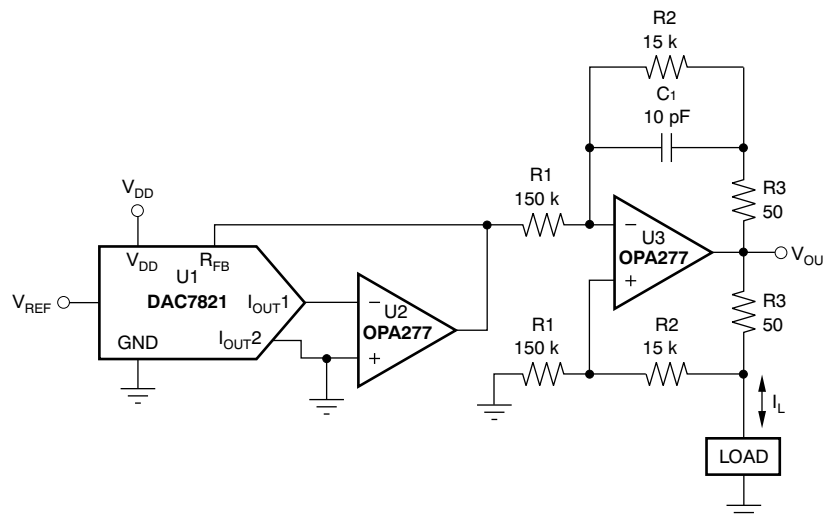

Figure 30. Programmable Bidirectional Current Source Circuit

APPLICATION INFORMATION (continued)

Parallel Interface

Data is loaded to the DAC7821 as a 12-bit parallel word. The bi-directional bus is controlled with \overline{CS} and R/\overline{W} , allowing data to be written to or read from the DAC register. To write to the device, \overline{CS} and R/\overline{W} are brought low, and data available on the data lines fills the input register. The rising edge of \overline{CS} latches the data and transfers the latched data-word to the DAC register. The DAC latches are not transparent; therefore, a write sequence must consist of a falling and rising edge on \overline{CS} in order to ensure that data is loaded to the DAC register and its analog equivalent is reflected on the DAC output.

To read data stored in the device, R/\overline{W} is held high and \overline{CS} is brought low. Data is loaded from the DAC register back to the input register and out onto the data line, where it can be read back to the controller.

Cross-Reference

The DAC7821 has an industry-standard pinout. [Table 1](#) provides the cross-reference information.

Table 1. Cross-Reference

PRODUCT	INL (LSB)	DNL (LSB)	SPECIFIED TEMPERATURE RANGE	PACKAGE DESCRIPTION	PACKAGE OPTION	CROSS-REFERENCE PART
DAC7821	±1	±1	–40°C to +125°C	20-Lead TSSOP	TSSOP-20	AD5445
DAC7821	±1	±1	–40°C to +125°C	20-Lead QFN ⁽¹⁾	QFN-20	AD5445

(1) Available 2Q 2006.

PACKAGING INFORMATION

Orderable Device	Status ⁽¹⁾	Package Type	Package Drawing	Pins	Package Qty	Eco Plan ⁽²⁾	Lead/Ball Finish	MSL Peak Temp ⁽³⁾
DAC7821IPW	ACTIVE	TSSOP	PW	20	78	Green (RoHS & no Sb/Br)	CU NIPDAU	Level-3-260C-168 HR
DAC7821IPWG4	ACTIVE	TSSOP	PW	20	78	Green (RoHS & no Sb/Br)	CU NIPDAU	Level-3-260C-168 HR
DAC7821IPWR	ACTIVE	TSSOP	PW	20	2000	Green (RoHS & no Sb/Br)	CU NIPDAU	Level-3-260C-168 HR
DAC7821IPWRG4	ACTIVE	TSSOP	PW	20	2000	Green (RoHS & no Sb/Br)	CU NIPDAU	Level-3-260C-168 HR
DAC7821IRGPR	PREVIEW	QFN	RGP	20	3000	TBD	Call TI	Call TI
DAC7821IRGPT	PREVIEW	QFN	RGP	20	250	TBD	Call TI	Call TI

⁽¹⁾ The marketing status values are defined as follows:

ACTIVE: Product device recommended for new designs.

LIFEBUY: TI has announced that the device will be discontinued, and a lifetime-buy period is in effect.

NRND: Not recommended for new designs. Device is in production to support existing customers, but TI does not recommend using this part in a new design.

PREVIEW: Device has been announced but is not in production. Samples may or may not be available.

OBSOLETE: TI has discontinued the production of the device.

⁽²⁾ Eco Plan - The planned eco-friendly classification: Pb-Free (RoHS), Pb-Free (RoHS Exempt), or Green (RoHS & no Sb/Br) - please check <http://www.ti.com/productcontent> for the latest availability information and additional product content details.

TBD: The Pb-Free/Green conversion plan has not been defined.

Pb-Free (RoHS): TI's terms "Lead-Free" or "Pb-Free" mean semiconductor products that are compatible with the current RoHS requirements for all 6 substances, including the requirement that lead not exceed 0.1% by weight in homogeneous materials. Where designed to be soldered at high temperatures, TI Pb-Free products are suitable for use in specified lead-free processes.

Pb-Free (RoHS Exempt): This component has a RoHS exemption for either 1) lead-based flip-chip solder bumps used between the die and package, or 2) lead-based die adhesive used between the die and leadframe. The component is otherwise considered Pb-Free (RoHS compatible) as defined above.

Green (RoHS & no Sb/Br): TI defines "Green" to mean Pb-Free (RoHS compatible), and free of Bromine (Br) and Antimony (Sb) based flame retardants (Br or Sb do not exceed 0.1% by weight in homogeneous material)

⁽³⁾ MSL, Peak Temp. -- The Moisture Sensitivity Level rating according to the JEDEC industry standard classifications, and peak solder temperature.

Important Information and Disclaimer:The information provided on this page represents TI's knowledge and belief as of the date that it is provided. TI bases its knowledge and belief on information provided by third parties, and makes no representation or warranty as to the accuracy of such information. Efforts are underway to better integrate information from third parties. TI has taken and continues to take reasonable steps to provide representative and accurate information but may not have conducted destructive testing or chemical analysis on incoming materials and chemicals. TI and TI suppliers consider certain information to be proprietary, and thus CAS numbers and other limited information may not be available for release.

In no event shall TI's liability arising out of such information exceed the total purchase price of the TI part(s) at issue in this document sold by TI to Customer on an annual basis.

RGP (S-PQFP-N20)

PLASTIC QUAD FLATPACK

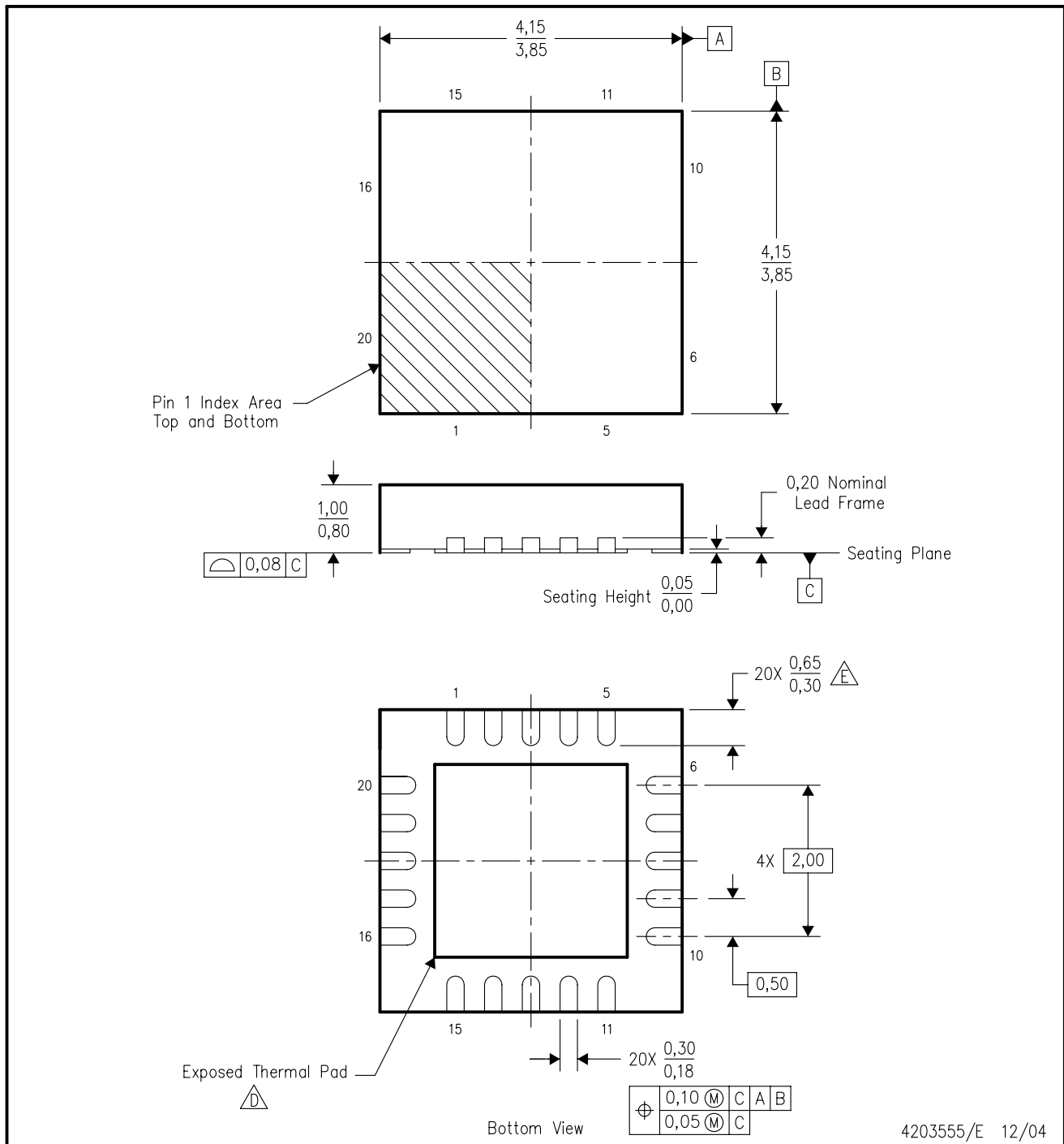

- NOTES:
- A. All linear dimensions are in millimeters. Dimensioning and tolerancing per ASME Y14.5M-1994.
 - B. This drawing is subject to change without notice.
 - C. QFN (Quad Flatpack No-Lead) package configuration.
 - D. The package thermal pad must be soldered to the board for thermal and mechanical performance. See the Product Data Sheet for details regarding the exposed thermal pad dimensions.
 - E. Check thermal pad mechanical drawing in the product datasheet for nominal lead length dimensions.

PW (R-PDSO-G**)

PLASTIC SMALL-OUTLINE PACKAGE

14 PINS SHOWN



4040064/F 01/97

- NOTES: A. All linear dimensions are in millimeters.
 B. This drawing is subject to change without notice.
 C. Body dimensions do not include mold flash or protrusion not to exceed 0,15.
 D. Falls within JEDEC MO-153

IMPORTANT NOTICE

Texas Instruments Incorporated and its subsidiaries (TI) reserve the right to make corrections, modifications, enhancements, improvements, and other changes to its products and services at any time and to discontinue any product or service without notice. Customers should obtain the latest relevant information before placing orders and should verify that such information is current and complete. All products are sold subject to TI's terms and conditions of sale supplied at the time of order acknowledgment.

TI warrants performance of its hardware products to the specifications applicable at the time of sale in accordance with TI's standard warranty. Testing and other quality control techniques are used to the extent TI deems necessary to support this warranty. Except where mandated by government requirements, testing of all parameters of each product is not necessarily performed.

TI assumes no liability for applications assistance or customer product design. Customers are responsible for their products and applications using TI components. To minimize the risks associated with customer products and applications, customers should provide adequate design and operating safeguards.

TI does not warrant or represent that any license, either express or implied, is granted under any TI patent right, copyright, mask work right, or other TI intellectual property right relating to any combination, machine, or process in which TI products or services are used. Information published by TI regarding third-party products or services does not constitute a license from TI to use such products or services or a warranty or endorsement thereof. Use of such information may require a license from a third party under the patents or other intellectual property of the third party, or a license from TI under the patents or other intellectual property of TI.

Reproduction of information in TI data books or data sheets is permissible only if reproduction is without alteration and is accompanied by all associated warranties, conditions, limitations, and notices. Reproduction of this information with alteration is an unfair and deceptive business practice. TI is not responsible or liable for such altered documentation.

Resale of TI products or services with statements different from or beyond the parameters stated by TI for that product or service voids all express and any implied warranties for the associated TI product or service and is an unfair and deceptive business practice. TI is not responsible or liable for any such statements.

Following are URLs where you can obtain information on other Texas Instruments products and application solutions:

Products		Applications	
Amplifiers	amplifier.ti.com	Audio	www.ti.com/audio
Data Converters	dataconverter.ti.com	Automotive	www.ti.com/automotive
DSP	dsp.ti.com	Broadband	www.ti.com/broadband
Interface	interface.ti.com	Digital Control	www.ti.com/digitalcontrol
Logic	logic.ti.com	Military	www.ti.com/military
Power Mgmt	power.ti.com	Optical Networking	www.ti.com/opticalnetwork
Microcontrollers	microcontroller.ti.com	Security	www.ti.com/security
		Telephony	www.ti.com/telephony
		Video & Imaging	www.ti.com/video
		Wireless	www.ti.com/wireless

Mailing Address: Texas Instruments
Post Office Box 655303 Dallas, Texas 75265

Copyright © 2006, Texas Instruments Incorporated