

## DAC121C081/ DAC121C085 12-Bit Micro Power Digital-to-Analog Converter with an I<sup>2</sup>C-Compatible Interface

Check for Samples: [DAC121C081](#), [DAC121C085](#)

### FEATURES

- **Guaranteed Monotonicity to 12-Bits**
- **Low Power Operation: 156  $\mu$ A Max @ 3.3V**
- **Extended Power Supply Range (+2.7V to +5.5V)**
- **I<sup>2</sup>C-Compatible 2-Wire Interface Which Supports Standard (100kHz), Fast (400kHz), and High Speed (3.4MHz) Modes**
- **Rail-to-Rail Voltage Output**
- **Very Small Package**

### APPLICATIONS

- **Industrial Process Control**
- **Portable Instruments**
- **Digital Gain and Offset Adjustment**
- **Programmable Voltage & Current Sources**
- **Test Equipment**

### KEY SPECIFICATIONS

- **Resolution: 12 bits**
- **INL:  $\pm 8$  LSB (max)**
- **DNL: +0.6 / -0.5 LSB (max)**
- **Settling Time: 8.5  $\mu$ s (max)**
- **Zero Code Error: +10 mV (max)**
- **Full-Scale Error: -0.7 %FS (max)**
- **Supply Power**
  - **Normal: 380  $\mu$ W (3V) / 730  $\mu$ W (5V) typ**
  - **Power Down: 0.5  $\mu$ W (3V) / 0.9  $\mu$ W (5V) typ**

### DESCRIPTION

The DAC121C081 is a 12-bit, single channel, voltage-output digital-to-analog converter (DAC) that operates from a +2.7V to 5.5V supply. The output amplifier allows rail-to-rail output swing and has an 8.5 $\mu$ sec settling time. The DAC121C081 uses the supply voltage as the reference to provide the widest dynamic output range and typically consumes 132 $\mu$ A while operating at 5.0V. It is available in 6-lead SOT and WSON packages and provides three address options (pin selectable).

As an alternative, the DAC121C085 provides nine I<sup>2</sup>C addressing options and uses an external reference. It has the same performance and settling time as the DAC121C081. It is available in an 8-lead VSSOP.

The DAC121C081 and DAC121C085 use a 2-wire, I<sup>2</sup>C-compatible serial interface that operates in all three speed modes, including high speed mode (3.4MHz). An external address selection pin allows up to three DAC121C081 or nine DAC121C085 devices per 2-wire bus. Pin compatible alternatives to the DAC121C081 are available that provide additional address options.

The DAC121C081 and DAC121C085 each have a 16-bit register that controls the mode of operation, the power-down condition, and the output voltage. A power-on reset circuit ensures that the DAC output powers up to zero volts. A power-down feature reduces power consumption to less than a microWatt. Their low power consumption and small packages make these DACs an excellent choice for use in battery operated equipment. Each DAC operates over the extended industrial temperature range of -40°C to +125°C.

The DAC121C081 and DAC121C085 are each part of a family of pin compatible DACs that also provide 8 and 10 bit resolution. For 8-bit DACs see the DAC081C081 and DAC081C085. For 10-bit DACs see the DAC101C081 and DAC101C085.



Please be aware that an important notice concerning availability, standard warranty, and use in critical applications of Texas Instruments semiconductor products and disclaimers thereto appears at the end of this data sheet.

I<sup>2</sup>C is a registered trademark of Phillips Corporation.  
All other trademarks are the property of their respective owners.

**Pin-Compatible Alternatives**  
**All devices are fully pin and function compatible.**

Resolution	SOT-6 and WSONP-6 Packages	VSSOP-8 Package w/ External Reference
12-bit	DAC121C081	DAC121C085
10-bit	DAC101C081	DAC101C085
8-bit	DAC081C081	DAC081C085

**Connection Diagrams**

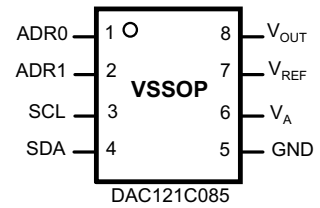
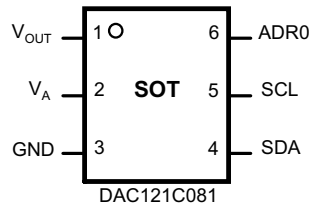
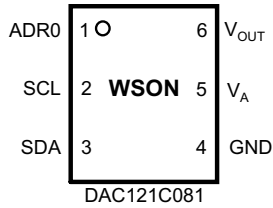

**Block Diagram**

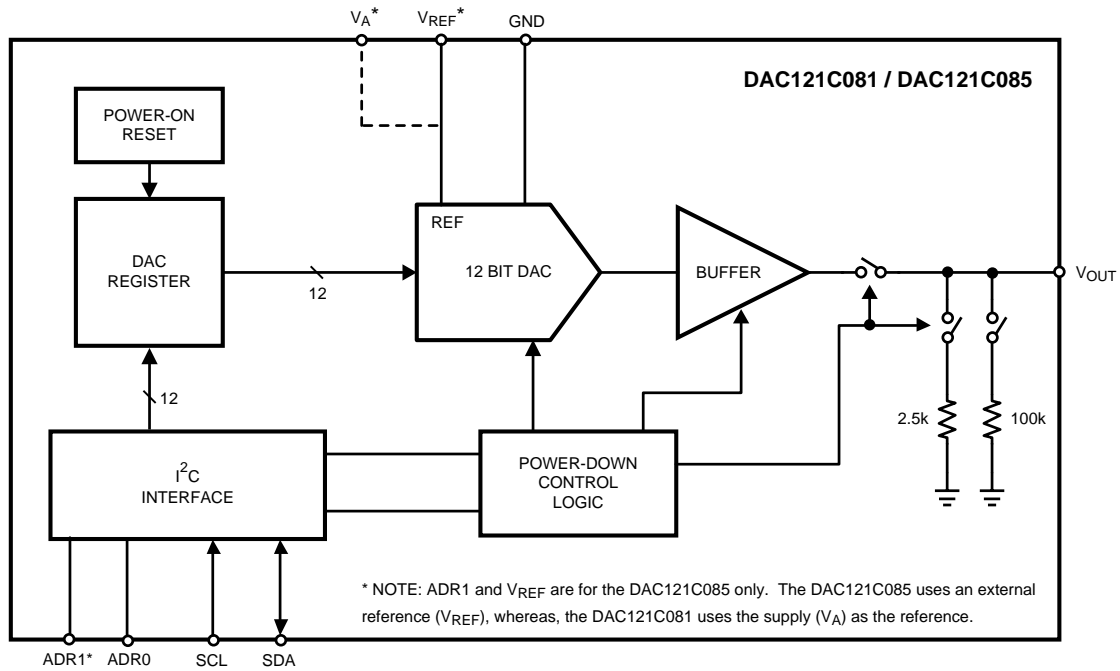

**PIN DESCRIPTIONS**

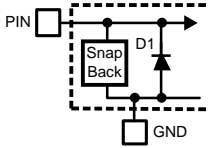
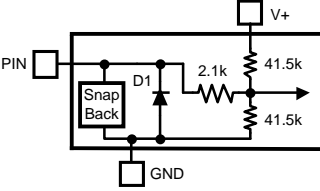
Symbol	Type	Equivalent Circuit	Description
V <sub>OUT</sub>	Analog Output		Analog Output Voltage.
V <sub>A</sub>	Supply		Power supply input. For the SOT and WSON versions, this supply is used as the reference. Must be decoupled to GND.
GND	Ground		Ground for all on-chip circuitry.
SDA	Digital Input/Output		Serial Data bi-directional connection. Data is clocked into or out of the internal 16-bit register relative to the clock edges of SCL. This is an open drain data line that must be pulled to the supply (V <sub>A</sub> ) by an external pull-up resistor.
SCL	Digital Input		Serial Clock Input. SCL is used together with SDA to control the transfer of data in and out of the device.
ADR0	Digital Input, three levels		Tri-state Address Selection Input. Sets the two Least Significant Bits (A1 & A0) of the 7-bit slave address. (see <a href="#">Table 1</a> )
ADR1	Digital Input, three levels		Tri-state Address Selection Input. Sets Bits A6 & A3 of the 7-bit slave address. (see <a href="#">Table 1</a> )
V <sub>REF</sub>	Supply		Unbuffered reference voltage. For the VSSOP, this supply is used as the reference. V <sub>REF</sub> must be free of noise and decoupled to GND.
PAD (LLP only)	Ground		Exposed die attach pad can be connected to ground or left floating. Soldering the pad to the PCB offers optimal thermal performance and enhances package self-alignment during reflow.

**Package Pinouts**

	V <sub>OUT</sub>	V <sub>A</sub>	GND	SDA	SCL	ADR0	ADR1	V <sub>REF</sub>	PAD (WSON only)
<b>SOT</b>	1	2	3	4	5	6	N/A	N/A	N/A
<b>WSON</b>	6	5	4	3	2	1	N/A	N/A	7
<b>VSSOP</b>	8	6	5	4	3	1	2	7	N/A



These devices have limited built-in ESD protection. The leads should be shorted together or the device placed in conductive foam during storage or handling to prevent electrostatic damage to the MOS gates.

**Absolute Maximum Ratings**<sup>(1)(2)(3)</sup>

Supply Voltage, $V_A$		-0.3V to +6.5V	
Voltage on any Input Pin		-0.3V to +6.5V	
Input Current at Any Pin <sup>(4)</sup>		±10 mA	
Package Input Current <sup>(4)</sup>		±20 mA	
Power Consumption at $T_A = 25^\circ\text{C}$		See <sup>(5)</sup>	
ESD Susceptibility <sup>(6)</sup>	$V_A$ , GND, $V_{REF}$ , $V_{OUT}$ , ADR0, ADR1 pins	Human Body Model	2500V
		Machine Model	250V
		Charged Device Model (CDM)	1000V
	SDA, SCL pins	Human Body Model	5000V
		Machine Model	350V
		Charged Device Model (CDM)	1000V
Junction Temperature		+150°C	
Storage Temperature		-65°C to +150°C	

- (1) Absolute Maximum Ratings indicate limits beyond which damage to the device may occur. Operating Ratings indicate conditions for which the device is functional, but do not ensure specific performance limits. For ensured specifications and test conditions, see the [Electrical Characteristics](#). The ensured specifications apply only for the test conditions listed. Some performance characteristics may degrade when the device is not operated under the listed test conditions. Operation of the device beyond the maximum Operating Ratings is not recommended.
- (2) All voltages are measured with respect to GND = 0V, unless otherwise specified.
- (3) If Military/Aerospace specified devices are required, please contact the Texas Instruments Sales Office/ Distributors for availability and specifications.
- (4) When the input voltage at any pin exceeds 5.5V or is less than GND, the current at that pin should be limited to 10 mA. The 20 mA maximum package input current rating limits the number of pins that can safely exceed the power supplies with an input current of 10 mA to two.
- (5) The absolute maximum junction temperature ( $T_{Jmax}$ ) for this device is 150°C. The maximum allowable power dissipation is dictated by  $T_{Jmax}$ , the junction-to-ambient thermal resistance ( $\theta_{JA}$ ), and the ambient temperature ( $T_A$ ), and can be calculated using the formula  $P_{DMAX} = (T_{Jmax} - T_A) / \theta_{JA}$ . The values for maximum power dissipation will be reached only when the device is operated in a severe fault condition (e.g., when input or output pins are driven beyond the operating ratings, or the power supply polarity is reversed).
- (6) Human body model is a 100 pF capacitor discharged through a 1.5 kΩ resistor. Machine model is a 220 pF capacitor discharged through 0 Ω. Charge device model simulates a pin slowly acquiring charge (such as from a device sliding down the feeder in an automated assembler) then rapidly being discharged.

**Operating Ratings**<sup>(1)(2)</sup>

Operating Temperature Range	-40°C ≤ $T_A$ ≤ +125°C
Supply Voltage, $V_A$	+2.7V to 5.5V
Reference Voltage, $V_{REFIN}$	+1.0V to $V_A$
Digital Input Voltage <sup>(3)</sup>	0.0V to 5.5V
Output Load	0 to 1500 pF

- (1) Absolute Maximum Ratings indicate limits beyond which damage to the device may occur. Operating Ratings indicate conditions for which the device is functional, but do not ensure specific performance limits. For ensured specifications and test conditions, see the [Electrical Characteristics](#). The ensured specifications apply only for the test conditions listed. Some performance characteristics may degrade when the device is not operated under the listed test conditions. Operation of the device beyond the maximum Operating Ratings is not recommended.
- (2) All voltages are measured with respect to GND = 0V, unless otherwise specified.
- (3) The inputs are protected as shown below. Input voltage magnitudes up to 5.5V, regardless of  $V_A$ , will not cause errors in the conversion result. For example, if  $V_A$  is 3V, the digital input pins can be driven with a 5V logic device.

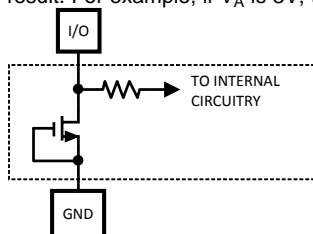

**Package Thermal Resistances<sup>(1)(2)</sup>**

Package	$\theta_{JA}$
6-Lead SOT	250°C/W
6-Lead WSON	190°C/W
8-Lead VSSOP	240°C/W

- (1) Soldering process must comply with Texas Instruments' Reflow Temperature Profile specifications. Refer to [http://www.ti.com/packaging \(SNOA549\)](http://www.ti.com/packaging(SNOA549))
- (2) Reflow temperature profiles are different for lead-free packages.

**Electrical Characteristics**

Values shown in this table are design targets and are subject to change before product release.

The following specifications apply for  $V_A = +2.7V$  to  $+5.5V$ ,  $V_{REF} = V_A$ ,  $C_L = 200$  pF to GND, input code range 48 to 4047.

**Boldface limits apply for  $T_{MIN} \leq T_A \leq T_{MAX}$**  and all other limits are at  $T_A = 25^\circ C$ , unless otherwise specified.

Symbol	Parameter	Conditions	Typical <sup>(1)</sup>	Limits <sup>(1)</sup>	Units (Limits)
<b>STATIC PERFORMANCE</b>					
	Resolution			<b>12</b>	Bits (min)
	Monotonicity			<b>12</b>	Bits (min)
INL	Integral Non-Linearity		+2.2	<b>+8</b>	LSB (max)
			-1.5	<b>-8</b>	LSB (min)
DNL	Differential Non-Linearity		+0.18	<b>+0.6</b>	LSB (max)
			-0.12	<b>-0.5</b>	LSB (min)
ZE	Zero Code Error	$I_{OUT} = 0$	+1.1	<b>+10</b>	mV (max)
FSE	Full-Scale Error	$I_{OUT} = 0$	-0.1	<b>-0.7</b>	%FSR (max)
GE	Gain Error	All ones Loaded to DAC register	-0.2	<b>-0.7</b>	%FSR (max)
ZCED	Zero Code Error Drift		-20		$\mu V/^\circ C$
TC GE	Gain Error Tempco	$V_A = 3V$	-0.7		ppm FSR/ $^\circ C$
		$V_A = 5V$	-1.0		ppm FSR/ $^\circ C$
<b>ANALOG OUTPUT CHARACTERISTICS (<math>V_{OUT}</math>)</b>					
	Output Voltage Range <sup>(2)</sup>	DAC121C085		<b>0</b> $V_{REF}$	V (min) V (max)
		DAC121C081		<b>0</b> $V_A$	V (min) V (max)
ZCO	Zero Code Output	$V_A = 3V, I_{OUT} = 200 \mu A$	1.3		mV
		$V_A = 5V, I_{OUT} = 200 \mu A$	7.0		mV
FSO	Full Scale Output	$V_A = 3V, I_{OUT} = 200 \mu A$	2.984		V
		$V_A = 5V, I_{OUT} = 200 \mu A$	4.989		V
$I_{OS}$	Output Short Circuit Current ( $I_{SOURCE}$ )	$V_A = 3V, V_{OUT} = 0V, \text{Input Code} = FFFh.$	56		mA
		$V_A = 5V, V_{OUT} = 0V, \text{Input Code} = FFFh.$	69		mA
$I_{OS}$	Output Short Circuit Current ( $I_{SINK}$ )	$V_A = 3V, V_{OUT} = 3V, \text{Input Code} = 000h.$	-52		mA
		$V_A = 5V, V_{OUT} = 5V, \text{Input Code} = 000h.$	-75		mA
$I_O$	Continuous Output Current <sup>(2)</sup>	Available on the DAC output		<b>11</b>	mA (max)
$C_L$	Maximum Load Capacitance	$R_L = \infty$	1500		pF
		$R_L = 2k\Omega$	1500		pF
$Z_{OUT}$	DC Output Impedance		7.5		$\Omega$
<b>REFERENCE INPUT CHARACTERISTICS- (DAC121C085 only)</b>					
$V_{REF}$	Input Range Minimum		0.2	<b>1.0</b>	V (min)
	Input Range Maximum			<b><math>V_A</math></b>	V (max)
	Input Impedance		120		k $\Omega$

(1) Typical figures are at  $T_J = 25^\circ C$ , and represent most likely parametric norms. Test limits are specified to AOQL (Average Outgoing Quality Level).

(2) This parameter is specified by design and/or characterization and is not tested in production.

**Electrical Characteristics (continued)**

Values shown in this table are design targets and are subject to change before product release.

The following specifications apply for  $V_A = +2.7V$  to  $+5.5V$ ,  $V_{REF} = V_A$ ,  $C_L = 200$  pF to GND, input code range 48 to 4047.

**Boldface limits apply for  $T_{MIN} \leq T_A \leq T_{MAX}$**  and all other limits are at  $T_A = 25^\circ C$ , unless otherwise specified.

Symbol	Parameter	Conditions	Typical <sup>(1)</sup>	Limits <sup>(1)</sup>	Units (Limits)	
<b>LOGIC INPUT CHARACTERISTICS (SCL, SDA)</b>						
$V_{IH}$	Input High Voltage			<b>0.7 x <math>V_A</math></b>	V (min)	
$V_{IL}$	Input Low Voltage			<b>0.3 x <math>V_A</math></b>	V (max)	
$I_{IN}$	Input Current			<b><math>\pm 1</math></b>	$\mu A$ (max)	
$C_{IN}$	Input Pin Capacitance <sup>(3)</sup>			<b>3</b>	pF (max)	
$V_{HYST}$	Input Hysteresis			<b>0.1 x <math>V_A</math></b>	V (min)	
<b>LOGIC INPUT CHARACTERISTICS (ADR0, ADR1)</b>						
$V_{IH}$	Input High Voltage			<b><math>V_A - 0.5V</math></b>	V (min)	
$V_{IL}$	Input Low Voltage			<b>0.5</b>	V (max)	
$I_{IN}$	Input Current			<b><math>\pm 1</math></b>	$\mu A$ (max)	
<b>LOGIC OUTPUT CHARACTERISTICS (SDA)</b>						
$V_{OL}$	Output Low Voltage	$I_{SINK} = 3$ mA		<b>0.4</b>	V (max)	
		$I_{SINK} = 6$ mA		<b>0.6</b>	V (max)	
$I_{OZ}$	High-Impedance Output Leakage Current			<b><math>\pm 1</math></b>	$\mu A$ (max)	
<b>POWER REQUIREMENTS</b>						
$V_A$	Supply Voltage Minimum			<b>2.7</b>	V (min)	
	Supply Voltage Maximum			<b>5.5</b>	V (max)	
Normal -- $V_{OUT}$ set to midscale. 2-wire interface quiet (SCL = SDA = $V_A$ ). (output unloaded)						
$I_{ST\_VA-1}$	$V_A$ <b>DAC121C081</b> Supply Current		$V_A = 2.7V$ to $3.6V$	105	<b>156</b>	$\mu A$ (max)
			$V_A = 4.5V$ to $5.5V$	132	<b>214</b>	$\mu A$ (max)
$I_{ST\_VA-5}$	$V_A$ <b>DAC121C085</b> Supply Current		$V_A = 2.7V$ to $3.6V$	86	<b>118</b>	$\mu A$ (max)
			$V_A = 4.5V$ to $5.5V$	98	<b>152</b>	$\mu A$ (max)
$I_{ST\_VREF}$	$V_{REF}$ Supply Current (DAC121C085 only)		$V_A = 2.7V$ to $3.6V$	37	<b>43</b>	$\mu A$ (max)
			$V_A = 4.5V$ to $5.5V$	53	<b>61</b>	$\mu A$ (max)
$P_{ST}$	Power Consumption ( $V_A$ & $V_{REF}$ for DAC121C085) <sup>(4)</sup>		$V_A = 3.0V$	380		$\mu W$
			$V_A = 5.0V$	730		$\mu W$
Continuous Operation -- 2-wire interface actively addressing the DAC and writing to the DAC register. (output unloaded)						
$I_{CO\_VA-1}$	$V_A$ <b>DAC121C081</b> Supply Current	$f_{SCL} = 400kHz$	$V_A = 2.7V$ to $3.6V$	134	<b>220</b>	$\mu A$ (max)
			$V_A = 4.5V$ to $5.5V$	192	<b>300</b>	$\mu A$ (max)
		$f_{SCL} = 3.4MHz$	$V_A = 2.7V$ to $3.6V$	225	<b>320</b>	$\mu A$ (max)
			$V_A = 4.5V$ to $5.5V$	374	<b>500</b>	$\mu A$ (max)
$I_{CO\_VA-5}$	$V_A$ <b>DAC121C085</b> Supply Current	$f_{SCL} = 400kHz$	$V_A = 2.7V$ to $3.6V$	101	<b>155</b>	$\mu A$ (max)
			$V_A = 4.5V$ to $5.5V$	142	<b>220</b>	$\mu A$ (max)
		$f_{SCL} = 3.4MHz$	$V_A = 2.7V$ to $3.6V$	193	<b>235</b>	$\mu A$ (max)
			$V_A = 4.5V$ to $5.5V$	325	<b>410</b>	$\mu A$ (max)
$I_{CO\_VREF}$	$V_{REF}$ Supply Current (DAC121C085 only)		$V_A = 2.7V$ to $3.6V$	33.5	<b>55</b>	$\mu A$ (max)
			$V_A = 4.5V$ to $5.5V$	49.5	<b>71.4</b>	$\mu A$ (max)
$P_{CO}$	Power Consumption ( $V_A$ & $V_{REF}$ for DAC121C085)	$f_{SCL} = 400kHz$	$V_A = 3.0V$	480		$\mu W$
			$V_A = 5.0V$	1.06		mW
		$f_{SCL} = 3.4MHz$	$V_A = 3.0V$	810		$\mu W$
			$V_A = 5.0V$	2.06		mW

(3) This parameter is specified by design and/or characterization and is not tested in production.

(4) To ensure accuracy, it is required that  $V_A$  and  $V_{REF}$  be well bypassed.

## Electrical Characteristics (continued)

Values shown in this table are design targets and are subject to change before product release.

The following specifications apply for  $V_A = +2.7V$  to  $+5.5V$ ,  $V_{REF} = V_A$ ,  $C_L = 200$  pF to GND, input code range 48 to 4047.

**Boldface limits apply for  $T_{MIN} \leq T_A \leq T_{MAX}$**  and all other limits are at  $T_A = 25^\circ C$ , unless otherwise specified.

Symbol	Parameter	Conditions	Typical <sup>(1)</sup>	Limits <sup>(1)</sup>	Units (Limits)	
Power Down -- 2-wire interface quiet (SCL = SDA = $V_A$ ) after PD mode written to DAC register. (output unloaded)						
$I_{PD}$	Supply Current ( $V_A$ & $V_{REF}$ for DAC121C085)	All Power Down Modes	$V_A = 2.7V$ to $3.6V$	0.13	<b>1.52</b>	$\mu A$ (max)
			$V_A = 4.5V$ to $5.5V$	0.15	<b>3.25</b>	$\mu A$ (max)
$P_{PD}$	Power Consumption ( $V_A$ & $V_{REF}$ for DAC121C085)	All Power Down Modes	$V_A = 3.0V$	0.5		$\mu W$
			$V_A = 5.0V$	0.9		$\mu W$

## A.C. and Timing Characteristics

Values shown in this table are design targets and are subject to change before product release.

The following specifications apply for  $V_A = +2.7V$  to  $+5.5V$ ,  $V_{REF} = V_A$ ,  $R_L = \text{Infinity}$ ,  $C_L = 200$  pF to GND. **Boldface limits**

**apply for  $T_{MIN} \leq T_A \leq T_{MAX}$**  and all other limits are at  $T_A = 25^\circ C$ , unless otherwise specified.

Symbol	Parameter	Conditions <sup>(1)</sup>	Typical <sup>(2)</sup>	Limits <sup>(1)(2)</sup>	Units (Limits)
$t_s$	Output Voltage Settling Time <sup>(3)</sup>	400h to C00h code change $R_L = 2k\Omega$ , $C_L = 200$ pF	6	<b>8.5</b>	$\mu s$ (max)
SR	Output Slew Rate		1		V/ $\mu s$
	Glitch Impulse	Code change from 800h to 7FFh	12		nV-sec
	Digital Feedthrough		0.5		nV-sec
	Multiplying Bandwidth <sup>(4)</sup>	$V_{REF} = 2.5V \pm 0.1V_{pp}$	160		kHz
	Total Harmonic Distortion <sup>(4)</sup>	$V_{REF} = 2.5V \pm 0.1V_{pp}$ input frequency = 10kHz	70		dB
$t_{WU}$	Wake-Up Time	$V_A = 3V$	0.8		$\mu sec$
		$V_A = 5V$	0.5		$\mu sec$

### DIGITAL TIMING SPECS (SCL, SDA)

$f_{SCL}$	Serial Clock Frequency	Standard Mode		<b>100</b>	kHz (max)
		Fast Mode		<b>400</b>	kHz (max)
		High Speed Mode, $C_b = 100pF$		<b>3.4</b>	MHz (max)
		High Speed Mode, $C_b = 400pF$		<b>1.7</b>	MHz (max)
$t_{LOW}$	SCL Low Time	Standard Mode		<b>4.7</b>	$\mu s$ (min)
		Fast Mode		<b>1.3</b>	$\mu s$ (min)
		High Speed Mode, $C_b = 100pF$		<b>160</b>	ns (min)
		High Speed Mode, $C_b = 400pF$		<b>320</b>	ns (min)
$t_{HIGH}$	SCL High Time	Standard Mode		<b>4.0</b>	$\mu s$ (min)
		Fast Mode		<b>0.6</b>	$\mu s$ (min)
		High Speed Mode, $C_b = 100pF$		<b>60</b>	ns (min)
		High Speed Mode, $C_b = 400pF$		<b>120</b>	ns (min)
$t_{SU,DAT}$	Data Setup Time	Standard Mode		<b>250</b>	ns (min)
		Fast Mode		<b>100</b>	ns (min)
		High Speed Mode		<b>10</b>	ns (min)

(1)  $C_b$  refers to the capacitance of one bus line.  $C_b$  is expressed in pF units.

(2) Typical figures are at  $T_J = 25^\circ C$ , and represent most likely parametric norms. Test limits are specified to AOQL (Average Outgoing Quality Level).

(3) This parameter is specified by design and/or characterization and is not tested in production.

(4) Applies to the Multiplying DAC configuration. In this configuration, the reference is used as the analog input. The value loaded in the DAC Register will digitally attenuate the signal at  $V_{out}$ .



**A.C. and Timing Characteristics (continued)**

Values shown in this table are design targets and are subject to change before product release.

The following specifications apply for  $V_A = +2.7V$  to  $+5.5V$ ,  $V_{REF} = V_A$ ,  $R_L = \text{Infinity}$ ,  $C_L = 200 \text{ pF}$  to GND. **Boldface limits apply for  $T_{MIN} \leq T_A \leq T_{MAX}$**  and all other limits are at  $T_A = 25^\circ\text{C}$ , unless otherwise specified.

Symbol	Parameter	Conditions <sup>(1)</sup>	Typical <sup>(2)</sup>	Limits <sup>(1)(2)</sup>	Units (Limits)
$t_{HD, DAT}$	Data Hold Time	Standard Mode		<b>0</b> <b>3.45</b>	$\mu\text{s}$ (min) $\mu\text{s}$ (max)
		Fast Mode		<b>0</b> <b>0.9</b>	$\mu\text{s}$ (min) $\mu\text{s}$ (max)
		High Speed Mode, $C_b = 100\text{pF}$		<b>0</b> <b>70</b>	ns (min) ns (max)
		High Speed Mode, $C_b = 400\text{pF}$		<b>0</b> <b>150</b>	ns (min) ns (max)
$t_{SU, STA}$	Setup time for a start or a repeated start condition	Standard Mode		<b>4.7</b>	$\mu\text{s}$ (min)
		Fast Mode		<b>0.6</b>	$\mu\text{s}$ (min)
		High Speed Mode		<b>160</b>	ns (min)
$t_{HD, STA}$	Hold time for a start or a repeated start condition	Standard Mode		<b>4.0</b>	$\mu\text{s}$ (min)
		Fast Mode		<b>0.6</b>	$\mu\text{s}$ (min)
		High Speed Mode		<b>160</b>	ns (min)
$t_{BUF}$	Bus free time between a stop and start condition	Standard Mode		<b>4.7</b>	$\mu\text{s}$ (min)
		Fast Mode		<b>1.3</b>	$\mu\text{s}$ (min)
$t_{SU, STO}$	Setup time for a stop condition	Standard Mode		<b>4.0</b>	$\mu\text{s}$ (min)
		Fast Mode		<b>0.6</b>	$\mu\text{s}$ (min)
		High Speed Mode		<b>160</b>	ns (min)
$t_{rDA}$	Rise time of SDA signal	Standard Mode		<b>1000</b>	ns (max)
		Fast Mode		<b><math>20+0.1C_b</math></b> <b>300</b>	ns (min) ns (max)
		High Speed Mode, $C_b = 100\text{pF}$		<b>10</b> <b>80</b>	ns (min) ns (max)
		High Speed Mode, $C_b = 400\text{pF}$		<b>20</b> <b>160</b>	ns (min) ns (max)
$t_{fDA}$	Fall time of SDA signal	Standard Mode		<b>250</b>	ns (max)
		Fast Mode		<b><math>20+0.1C_b</math></b> <b>250</b>	ns (min) ns (max)
		High Speed Mode, $C_b = 100\text{pF}$		<b>10</b> <b>80</b>	ns (min) ns (max)
		High Speed Mode, $C_b = 400\text{pF}$		<b>20</b> <b>160</b>	ns (min) ns (max)
$t_{rCL}$	Rise time of SCL signal	Standard Mode		<b>1000</b>	ns (max)
		Fast Mode		<b><math>20+0.1C_b</math></b> <b>300</b>	ns (min) ns (max)
		High Speed Mode, $C_b = 100\text{pF}$		<b>10</b> <b>40</b>	ns (min) ns (max)
		High Speed Mode, $C_b = 400\text{pF}$		<b>20</b> <b>80</b>	ns (min) ns (max)
$t_{rCL1}$	Rise time of SCL signal after a repeated start condition and after an acknowledge bit.	Standard Mode		<b>1000</b>	ns (max)
		Fast Mode		<b><math>20+0.1C_b</math></b> <b>300</b>	ns (min) ns (max)
		High Speed Mode, $C_b = 100\text{pF}$		<b>10</b> <b>80</b>	ns (min) ns (max)
		High Speed Mode, $C_b = 400\text{pF}$		<b>20</b> <b>160</b>	ns (min) ns (max)



### A.C. and Timing Characteristics (continued)

Values shown in this table are design targets and are subject to change before product release.

The following specifications apply for  $V_A = +2.7V$  to  $+5.5V$ ,  $V_{REF} = V_A$ ,  $R_L = \text{Infinity}$ ,  $C_L = 200 \text{ pF}$  to GND. **Boldface limits apply for  $T_{MIN} \leq T_A \leq T_{MAX}$**  and all other limits are at  $T_A = 25^\circ\text{C}$ , unless otherwise specified.

Symbol	Parameter	Conditions <sup>(1)</sup>	Typical <sup>(2)</sup>	Limits <sup>(1)(2)</sup>	Units (Limits)
$t_{fCL}$	Fall time of a SCL signal	Standard Mode		<b>300</b>	ns (max)
		Fast Mode		<b>20+0.1C<sub>b</sub></b> <b>300</b>	ns (min) ns (max)
		High Speed Mode, $C_b = 100\text{pF}$		<b>10</b> <b>40</b>	ns (min) ns (max)
		High Speed Mode, $C_b = 400\text{pF}$		<b>20</b> <b>80</b>	ns (min) ns (max)
$C_b$	Capacitive load for each bus line (SCL and SDA)			<b>400</b>	pF (max)
$t_{SP}$	Pulse Width of spike suppressed <sup>(5)(6)</sup>	Fast Mode		<b>50</b>	ns (max)
		High Speed Mode		<b>10</b>	ns (max)
$t_{outz}$	SDA output delay (see the <a href="#">ADDITIONAL TIMING INFORMATION: toutz</a> section)	Fast Mode	87	<b>270</b>	ns (max)
		High Speed Mode	38	<b>60</b>	ns (max)

(5) Spike suppression filtering on SCL and SDA will suppress spikes that are less than 50ns for standard-fast mode and less than 10ns for hs-mode.

(6) This parameter is specified by design and/or characterization and is not tested in production.

## Specification Definitions

**DIFFERENTIAL NON-LINEARITY (DNL)** is the measure of the maximum deviation from the ideal step size of 1 LSB, which is  $V_{REF} / 4096 = V_A / 4096$ .

**DIGITAL FEEDTHROUGH** is a measure of the energy injected into the analog output of the DAC from the digital inputs when the DAC output is not updated. It is measured with a full-scale code change on the data bus.

**FULL-SCALE ERROR** is the difference between the actual output voltage with a full scale code (FFFh) loaded into the DAC and the value of  $V_A \times 4095 / 4096$ .

**GAIN ERROR** is the deviation from the ideal slope of the transfer function. It can be calculated from Zero and Full-Scale Errors as  $GE = FSE - ZE$ , where GE is Gain error, FSE is Full-Scale Error and ZE is Zero Error.

**GLITCH IMPULSE** is the energy injected into the analog output when the input code to the DAC register changes. It is specified as the area of the glitch in nanovolt-seconds.

**INTEGRAL NON-LINEARITY (INL)** is a measure of the deviation of each individual code from a straight line through the input to output transfer function. The deviation of any given code from this straight line is measured from the center of that code value. The end point method is used. INL for this product is specified over a limited range, per the [Electrical Characteristics](#).

**LEAST SIGNIFICANT BIT (LSB)** is the bit that has the smallest value or weight of all bits in a word. This value is

$$LSB = V_{REF} / 2^n \quad (1)$$

where  $V_{REF}$  is the supply voltage for this product, and "n" is the DAC resolution in bits, which is 12 for the DAC121C081.

**MAXIMUM LOAD CAPACITANCE** is the maximum capacitance that can be driven by the DAC with output stability maintained.

**MONOTONICITY** is the condition of being monotonic, where the DAC has an output that never decreases when the input code increases.

**MOST SIGNIFICANT BIT (MSB)** is the bit that has the largest value or weight of all bits in a word. Its value is 1/2 of  $V_A$ .

**MULTIPLYING BANDWIDTH** is the frequency at which the output amplitude falls 3dB below the input sine wave on  $V_{REFIN}$  with a full-scale code loaded into the DAC.

**POWER EFFICIENCY** is the ratio of the output current to the total supply current. The output current comes from the power supply. The difference between the supply and output currents is the power consumed by the device without a load.

**SETTLING TIME** is the time for the output to settle to within 1/2 LSB of the final value after the input code is updated.

**TOTAL HARMONIC DISTORTION (THD)** is the measure of the harmonics present at the output of the DACs with an ideal sine wave applied to  $V_{REFIN}$ . THD is measured in dB.

**WAKE-UP TIME** is the time for the output to exit power-down mode. This time is measured from the rising edge of SCL during the ACK bit of the lower data byte to the time the output voltage deviates from the power-down voltage of 0V.

**ZERO CODE ERROR** is the output error, or voltage, present at the DAC output after a code of 000h has been entered.

Transfer Characteristic

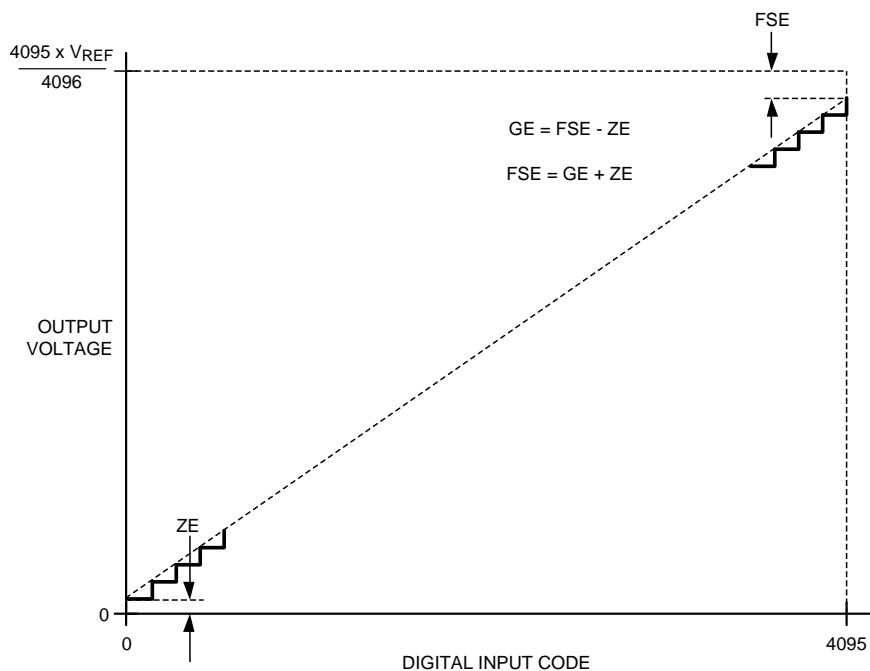

Figure 1. Input / Output Transfer Characteristic

Timing Diagrams

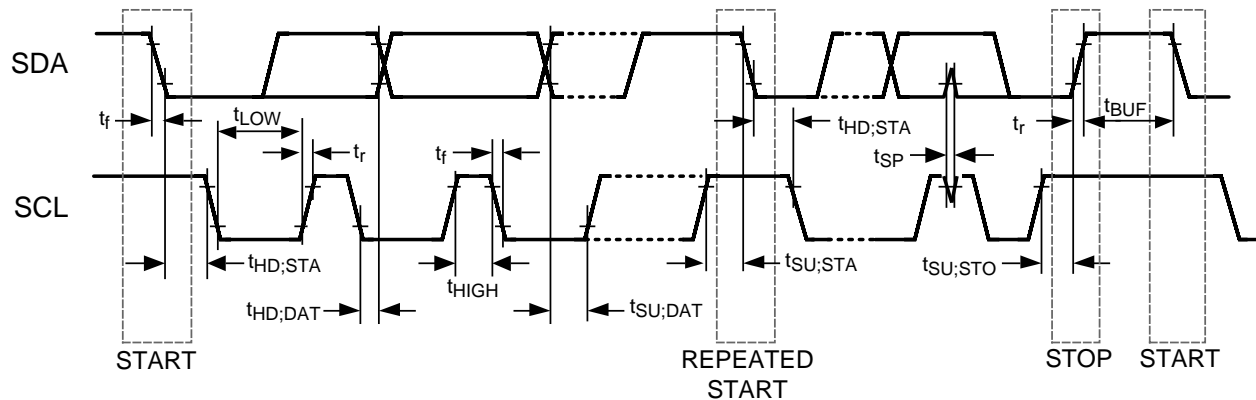

Figure 2. Serial Timing Diagram

### Typical Performance Characteristics

$V_{REF} = V_A$ ,  $f_{SCL} = 3.4\text{MHz}$ ,  $T_A = 25^\circ\text{C}$ , Input Code Range 48 to 4047, unless otherwise stated.

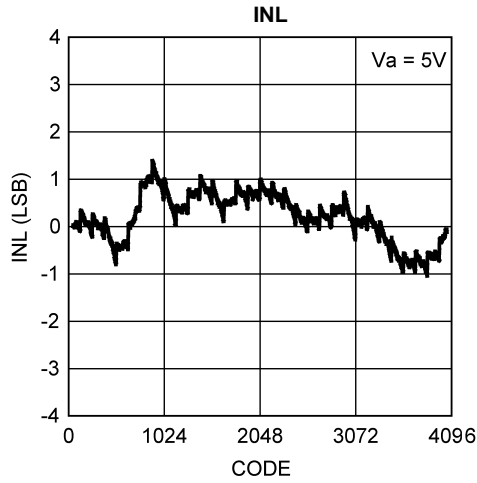

Figure 3.

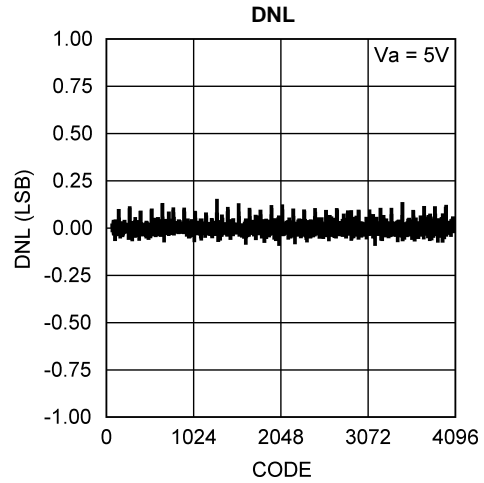

Figure 4.

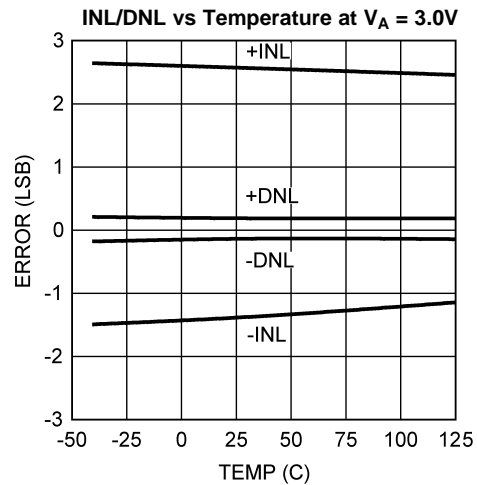

Figure 5.

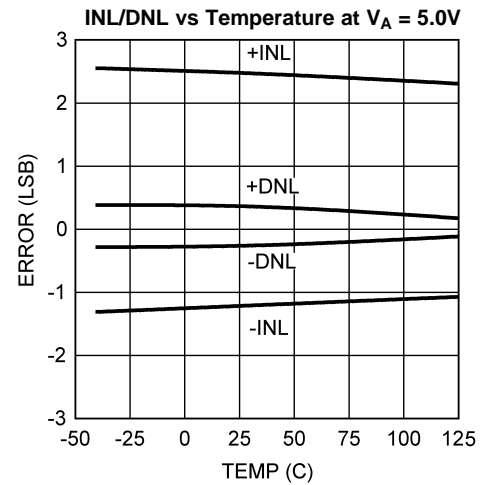

Figure 6.

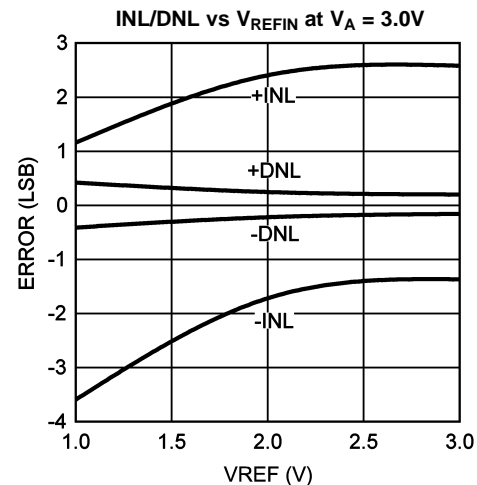

Figure 7.

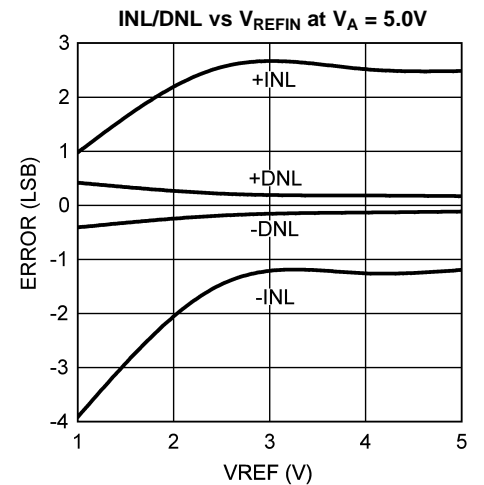

Figure 8.

Typical Performance Characteristics (continued)

$V_{REF} = V_A$ ,  $f_{SCL} = 3.4\text{MHz}$ ,  $T_A = 25^\circ\text{C}$ , Input Code Range 48 to 4047, unless otherwise stated.

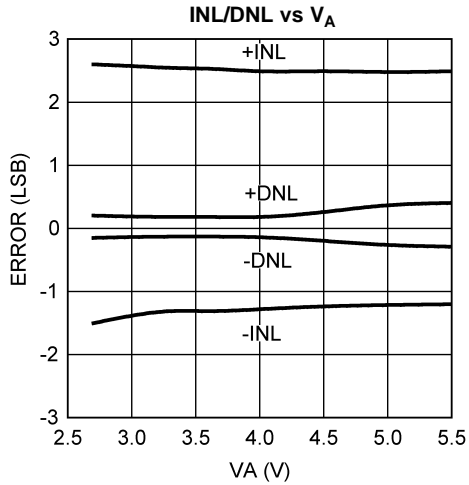

Figure 9.

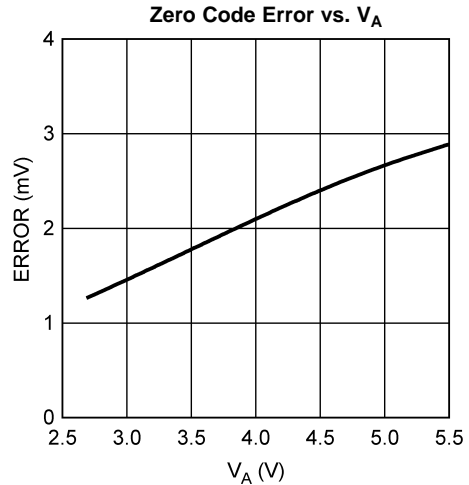

Figure 10.

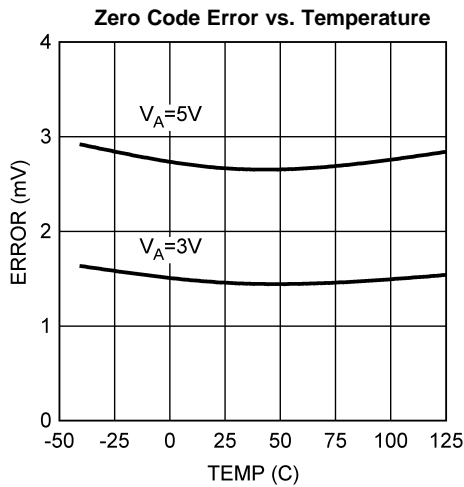

Figure 11.

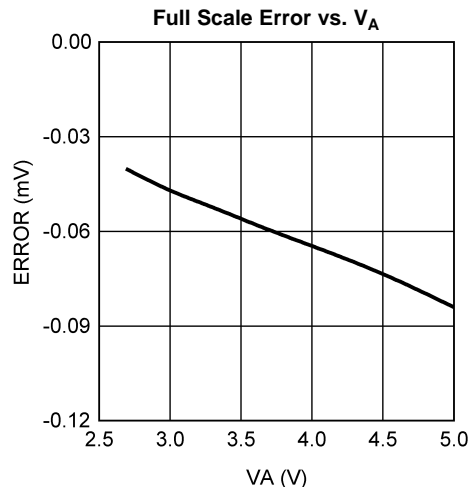

Figure 12.

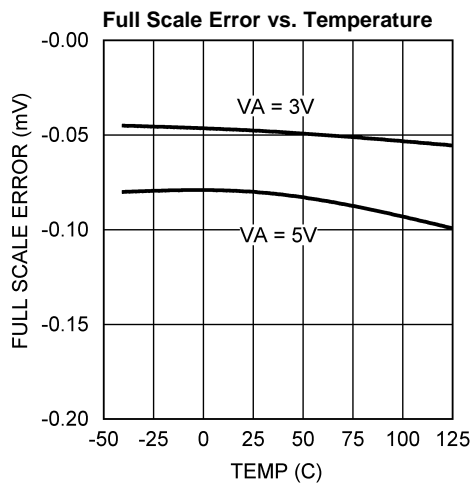

Figure 13.

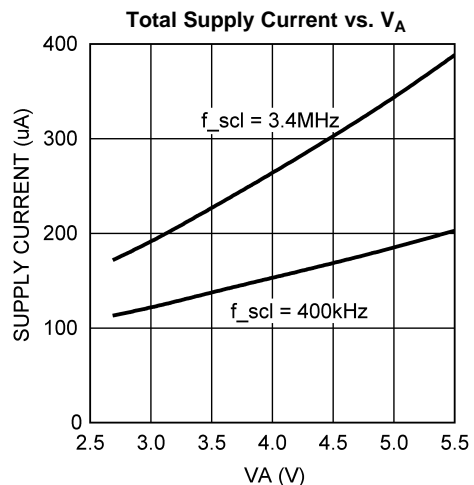

Figure 14.

**Typical Performance Characteristics (continued)**

$V_{REF} = V_A$ ,  $f_{SCL} = 3.4\text{MHz}$ ,  $T_A = 25^\circ\text{C}$ , Input Code Range 48 to 4047, unless otherwise stated.

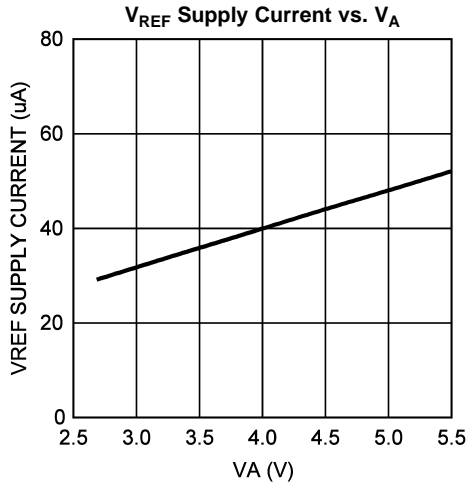

Figure 15.

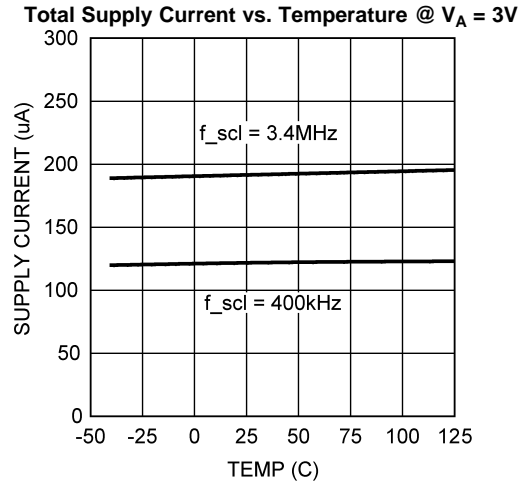

Figure 16.

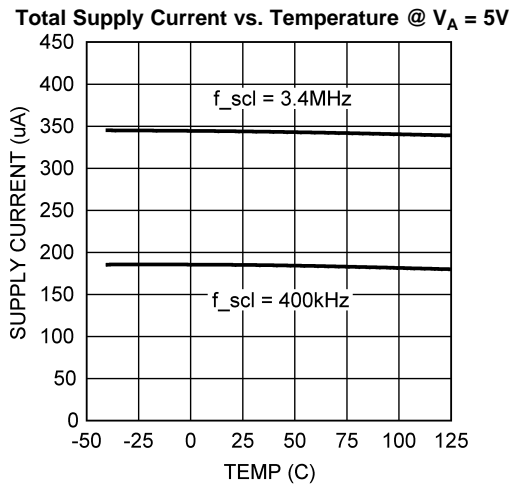

Figure 17.

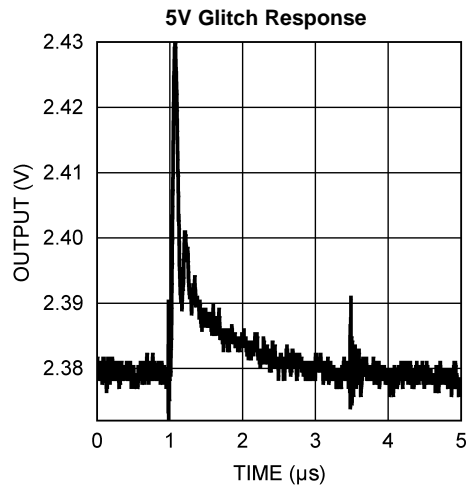

Figure 18.

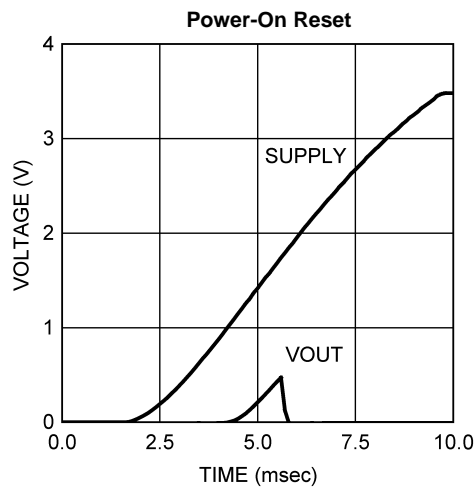

Figure 19.

## FUNCTIONAL DESCRIPTION

### DAC SECTION

The DAC121C081 is fabricated on a CMOS process with an architecture that consists of switches and resistor strings that are followed by an output buffer.

For simplicity, a single resistor string is shown in [Figure 20](#). This string consists of 4096 equal valued resistors with a switch at each junction of two resistors, plus a switch to ground. The code loaded into the DAC register determines which switch is closed, connecting the proper node to the amplifier. The input coding is straight binary with an ideal output voltage of:

$$V_{OUT} = V_{REF} \times (D / 4096) \quad (2)$$

where  $D$  is the decimal equivalent of the binary code that is loaded into the DAC register.  $D$  can take on any integer value between 0 and 4095. This configuration ensures that the DAC is monotonic.

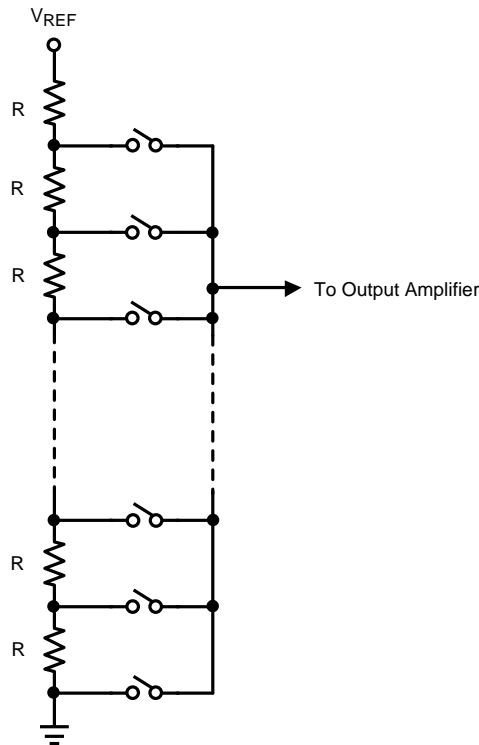

**Figure 20. DAC Resistor String**

### OUTPUT AMPLIFIER

The output amplifier is rail-to-rail, providing an output voltage range of 0V to  $V_A$  when the reference is  $V_A$ . All amplifiers, even rail-to-rail types, exhibit a loss of linearity as the output approaches the supply rails (0V and  $V_A$ , in this case). For this reason, linearity is specified over less than the full output range of the DAC. However, if the reference is less than  $V_A$ , there is only a loss in linearity in the lowest codes. The output capabilities of the amplifier are described in the [Electrical Characteristics](#).

The output amplifiers are capable of driving a load of 2 k $\Omega$  in parallel with 1500 pF to ground or to  $V_A$ . The zero-code and full-scale outputs for given load currents are available in the [Electrical Characteristics](#).

### REFERENCE VOLTAGE

The DAC121C081 uses the supply ( $V_A$ ) as the reference. With that said,  $V_A$  must be treated as a reference. The Analog output will only be as clean as the reference ( $V_A$ ). It is recommended that the reference be driven by a voltage source with low output impedance.



The DAC121C085 comes with an external reference supply pin ( $V_{REF}$ ). For the DAC121C085, it is important that  $V_{REF}$  be kept as clean as possible.

The [Applications Information](#) section describes a handful of ways to drive the reference appropriately. Refer to the [USING REFERENCES AS POWER SUPPLIES](#) section for details.

## SERIAL INTERFACE

The I<sup>2</sup>C-compatible interface operates in all three speed modes. Standard mode (100kHz) and Fast mode (400kHz) are functionally the same and will be referred to as Standard-Fast mode in this document. High-Speed mode (3.4MHz) is an extension of Standard-Fast mode and will be referred to as Hs-mode in this document. The following diagrams describe the timing relationships of the clock (SCL) and data (SDA) signals. Pull-up resistors or current sources are required on the SCL and SDA busses to pull them high when they are not being driven low. A logic zero is transmitted by driving the output low. A logic high is transmitted by releasing the output and allowing it to be pulled-up externally. The appropriate pull-up resistor values will depend upon the total bus capacitance and operating speed.

### Basic I<sup>2</sup>C Protocol

The I<sup>2</sup>C interface is bi-directional and allows multiple devices to operate on the same bus. To facilitate this bus configuration, each device has a unique hardware address which is referred to as the "slave address." To communicate with a particular device on the bus, the controller (master) sends the slave address and listens for a response from the slave. This response is referred to as an acknowledge bit. If a slave on the bus is addressed correctly, it Acknowledges (ACKs) the master by driving the SDA bus low. If the address doesn't match a device's slave address, it Not-acknowledges (NACKs) the master by letting SDA be pulled high. ACKs also occur on the bus when data is being transmitted. When the master is writing data, the slave ACKs after every data byte is successfully received. When the master is reading data, the master ACKs after every data byte is received to let the slave know it wants to receive another data byte. When the master wants to stop reading, it NACKs after the last data byte and creates a Stop condition on the bus.

All communication on the bus begins with either a Start condition or a Repeated Start condition. The protocol for starting the bus varies between Standard-Fast mode and Hs-mode. In Standard-Fast mode, the master generates a Start condition by driving SDA from high to low while SCL is high. In Hs-mode, starting the bus is more complicated. Please refer to the [High-Speed \(Hs\) Mode](#) section for the full details of a Hs-mode Start condition. A Repeated Start is generated to either address a different device, or switch between read and write modes. The master generates a Repeated Start condition by driving SDA low while SCL is high. Following the Repeated Start, the master sends out the slave address and a read/write bit as shown in [Figure 21](#). The bus continues to operate in the same speed mode as before the Repeated Start condition.

All communication on the bus ends with a Stop condition. In either Standard-Fast mode or Hs-Mode, a Stop condition occurs when SDA is pulled from low to high while SCL is high. After a Stop condition, the bus remains idle until a master generates a Start condition.

Please refer to the Phillips I<sup>2</sup>C<sup>®</sup> Specification (Version 2.1 Jan, 2000) for a detailed description of the serial interface.

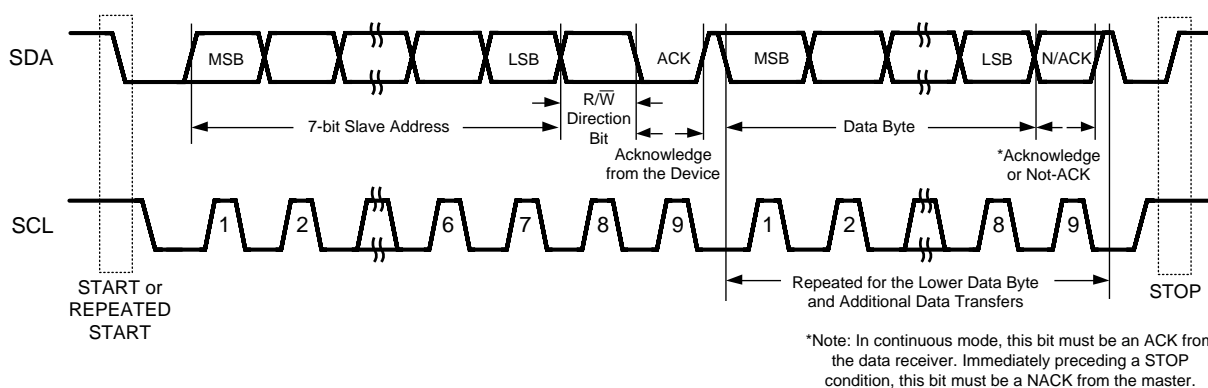

Figure 21. Basic Operation.

### Standard-Fast Mode

In Standard-Fast mode, the master generates a start condition by driving SDA from high to low while SCL is high. The Start condition is always followed by a 7-bit slave address and a Read/Write bit. After these eight bits have been transmitted by the master, SDA is released by the master and the DAC121C081 either ACKs or NACKs the address. If the slave address matches, the DAC121C081 ACKs the master. If the address doesn't match, the DAC121C081 NACKs the master.

For a **write** operation, the master follows the ACK by sending the upper eight data bits to the DAC121C081. Then the DAC121C081 ACKs the transfer by driving SDA low. Next, the lower eight data bits are sent by the master. The DAC121C081 then ACKs the transfer. At this point, the DAC output updates to reflect the contents of the 16-bit DAC register. Next, the master either sends another pair of data bytes, generates a Stop condition to end communication, or generates a Repeated Start condition to communicate with another device on the bus.

For a **read** operation, the DAC121C081 sends out the upper eight data bits of the DAC register. This is followed by an ACK by the master. Next, the lower eight data bits of the DAC register are sent to the master. The master then produces a NACK by letting SDA be pulled high. The NACK is followed by a master-generated Stop condition to end communication on the bus, or a Repeated Start to communicate with another device on the bus.

### High-Speed (Hs) Mode

For Hs-mode, the sequence of events to begin communication differ slightly from Standard-Fast mode. [Figure 22](#) describes this in further detail. Initially, the bus begins running in Standard-Fast mode. The master generates a Start condition and sends the 8-bit Hs master code (00001XXX) to the DAC121C081. Next, the DAC121C081 responds with a NACK. Once the SCL line has been pulled to a high level, the master switches to Hs-mode by increasing the bus speed and generating a Repeated Start condition (driving SDA low while SCL is pulled high). At this point, the master sends the slave address to the DAC121C081, and communication continues as shown above in the "Basic Operation" Diagram (see [Figure 21](#)).

When the master generates a Repeated Start condition while in Hs-mode, the bus stays in Hs-mode awaiting the slave address from the master. The bus continues to run in Hs-mode until a Stop condition is generated by the master. When the master generates a Stop condition on the bus, the bus must be started in Standard-Fast mode again before increasing the bus speed and switching to Hs-mode. ns16705

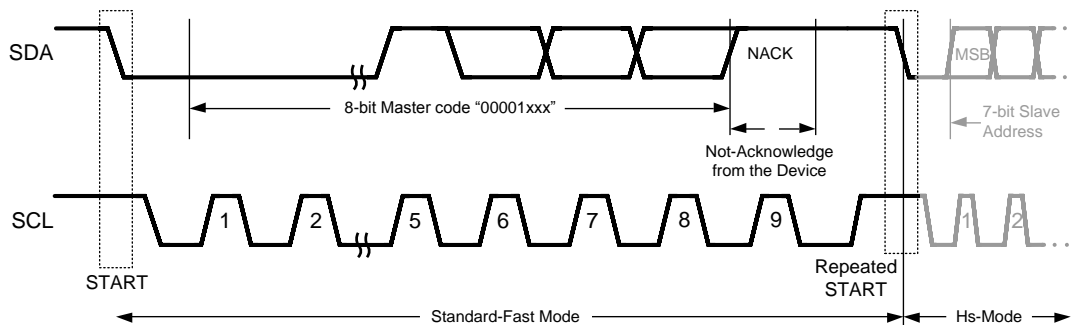

Figure 22. Beginning Hs-Mode Communication

### I<sup>2</sup>C Slave (Hardware) Address

The DAC has a seven-bit I<sup>2</sup>C slave address. For the VSSOP version of the DAC, this address is configured by the ADR0 and ADR1 address selection inputs. For the DAC121C081, the address is configured by the ADR0 address selection input. ADR0 and ADR1 can be grounded, left floating, or tied to V<sub>A</sub>. If desired, the address selection inputs can be set to V<sub>A</sub>/2 rather than left floating. The state of these inputs sets the address the DAC responds to on the I<sup>2</sup>C bus (see [Table 1](#)). In addition to the selectable slave address, there is also a broadcast address (1001000) for all DAC121C081's and DAC121C085's on the 2-wire bus. When the bus is addressed by the broadcast address, all the DAC121C081's and DAC121C085's will respond and update synchronously. [Figure 23](#) and [Figure 24](#) describe how the master device should address the DAC via the I<sup>2</sup>C-Compatible interface.

Keep in mind that the address selection inputs (ADR0 and ADR1) are only sampled until the DAC is correctly addressed with a non-broadcast address. At this point, the ADR0 and ADR1 inputs TRI-STATE and the slave address is "locked". Changes to ADR0 and ADR1 will not update the selected slave address until the device is power-cycled.

**Table 1. Slave Addresses**

Slave Address [A6 - A0]	DAC121C085 (VSSOP)		DAC121C081 (SOT & WSON) *
	ADR1	ADR0	ADR0
0001100	Floating	Floating	Floating
0001101	Floating	GND	GND
0001110	Floating	V <sub>A</sub>	V <sub>A</sub>
0001000	GND	Floating	-----
0001001	GND	GND	-----
0001010	GND	V <sub>A</sub>	-----
1001100	V <sub>A</sub>	Floating	-----
1001101	V <sub>A</sub>	GND	-----
1001110	V <sub>A</sub>	V <sub>A</sub>	-----
1001000	----- Broadcast Address -----		

\* Pin-compatible alternatives to the DAC121C081 options are available with additional address options.

**Writing to the DAC Register**

To write to the DAC, the master addresses the part with the correct slave address (A6-A0) and writes a "zero" to the read/write bit. If addressed correctly, the DAC returns an ACK to the master. The master then sends out the upper data byte. The DAC responds by sending an ACK again. Next, the master sends the lower data byte to the DAC. The DAC responds by sending an ACK again. At this point, the master either sends the upper byte of the next data word to be converted by the DAC, generates a Stop condition to end communication, or generates a Repeated Start condition to begin communication with another device on the bus. Until generating a Stop condition, the master can continuously write the upper and lower data bytes to the DAC register. This allows for a maximum DAC conversion rate of 188.9 kilo-conversions per second in Hs-mode.

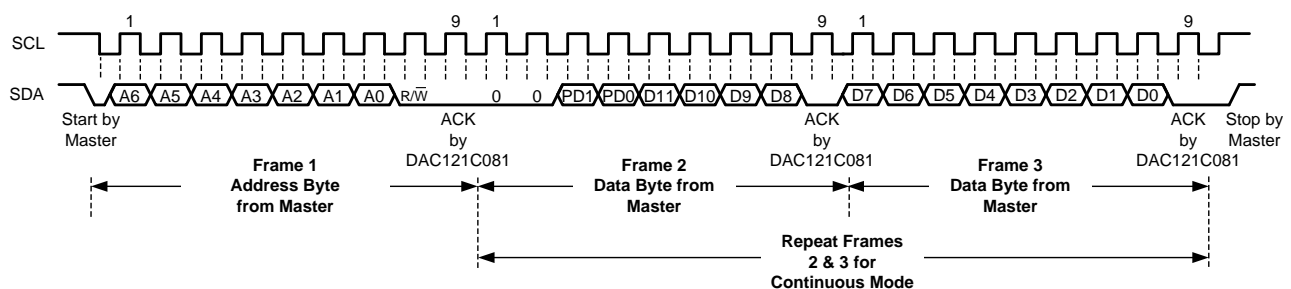

**Figure 23. Typical Write to the DAC Register**

**Reading from the DAC Register**

To read from the DAC register, the master addresses the part with the correct slave address (A6-A0) and writes a "one" to the read/write bit. If addressed correctly, the DAC returns an ACK to the master. Next, the DAC sends out the upper data byte. The master responds by sending an ACK to the DAC to indicate that it wants to receive another data byte. Then the DAC sends the lower data byte to the master. Assuming only one 16-bit data word is read, the master sends a NACK after receiving the lower data byte. At this point, the master either generates a Stop condition to end communication, or a Repeated Start condition to begin communication with another device on the bus.

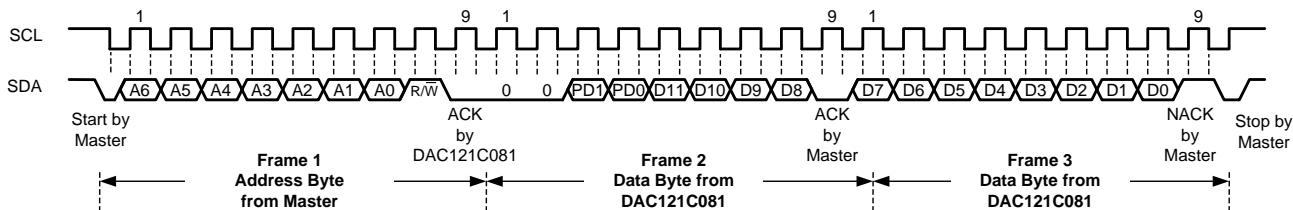

Figure 24. Typical Read from the DAC Register

### DAC REGISTER

The DAC register, Figure 25, has sixteen bits. The first two bits are always zero. The next two bits determine the mode of operation (normal mode or one of three power-down modes). The final twelve bits of the shift register are the data bits. The data format is straight binary (MSB first, LSB last), with twelve 0's corresponding to an output of 0V and twelve 1's corresponding to a full-scale output of  $V_A - 1$  LSB. When writing to the DAC Register,  $V_{OUT}$  will update on the rising edge of the ACK following the lower data byte.

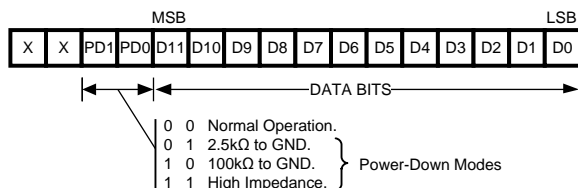

Figure 25. DAC Register Contents

### POWER-ON RESET

The power-on reset circuit controls the output voltage of the DAC during power-up. Upon application of power, the DAC register is filled with zeros and the output voltage is 0 Volts. The output remains at 0V until a valid write sequence is made to the DAC.

When resetting the device, it is crucial that the  $V_A$  supply be lowered to a maximum of 200mV before the supply is raised again to power-up the device. Dropping the supply to within 200mV of GND during a reset will ensure the ADC performs as specified.

### SIMULTANEOUS RESET

The broadcast address allows the I<sup>2</sup>C master to write a single word to multiple DACs simultaneously. Provided that all of the DACs exist on a single I<sup>2</sup>C bus, every DAC will update when the broadcast address is used to address the bus. This feature allows the master to reset all of the DACs on a shared I<sup>2</sup>C bus to a specific digital code. For instance, if the master writes a power-down code to the bus with the broadcast address, all of the DACs will power-down simultaneously.

### POWER-DOWN MODES

The DAC121C081 has three power-down modes. In power-down mode, the supply current drops to 0.13μA at 3V and 0.15μA at 5V (typ). The DAC121C081 is put into power-down mode by writing a one to PD1 and/or PD0. The outputs can be set to high impedance, terminated by 2.5 kΩ to GND, or terminated by 100 kΩ to GND (see Figure 25).

The bias generator, output amplifier, resistor string, and other linear circuitry are all shut down in any of the power-down modes. When the DAC121C081 is powered down, the value written to the DAC register, including the power-down bits, is saved. While the DAC is in power-down, the saved DAC register contents can be read back. When the DAC is brought out of power-down mode, the DAC register contents will be overwritten and  $V_{OUT}$  will be updated with the new 12-bit data value.

The time to exit power-down (Wake-Up Time) is typically 0.8μsec at 3V and 0.5μsec at 5V.

**ADDITIONAL TIMING INFORMATION:  $t_{outz}$**

The  $t_{outz}$  specification is provided to aid the design of the I<sup>2</sup>C bus. After the SCL bus is driven low by the I<sup>2</sup>C master, the SDA bus will be held for a short time by the DAC121C081. This time is referred to as  $t_{outz}$ . The following figure illustrates the relationship between the fall of SCL, at the 30% threshold, to the time when the DAC begins to transition the SDA bus. The  $t_{outz}$  specification only applies when the DAC is in control of the SDA bus. The DAC is only in control of the bus during an ACK by the DAC121C081 or a data byte read from the DAC (see Figure 24).

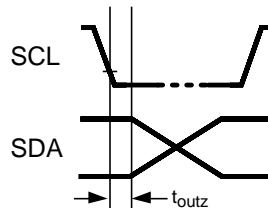

**Figure 26. Data Output Timing**

The  $t_{outz}$  specification is typically 87nsec in Standard-Fast Mode and 38nsec in Hs-Mode.

**Applications Information**

**USING REFERENCES AS POWER SUPPLIES**

While the simplicity of the DAC121C081 implies ease of use, it is important to recognize that the path from the reference input ( $V_A$  for the DAC121C081 &  $V_{REF}$  for the DAC121C085) to  $V_{OUT}$  will have essentially zero Power Supply Rejection Ratio (PSRR). Therefore, it is necessary to provide a noise-free supply voltage to the reference. In order to use the full dynamic range of the DAC121C085, the supply pin ( $V_A$ ) and  $V_{REF}$  can be connected together and share the same supply voltage. Since the DAC121C081 consumes very little power, a reference source may be used as the supply voltage. The advantages of using a reference source over a voltage regulator are accuracy and stability. Some low noise regulators can also be used. Listed below are a few reference and power supply options for the DAC121C081. When using the DAC121C081, it is important to treat the analog supply ( $V_A$ ) as the reference.

**LM4132**

The LM4132, with its 0.05% accuracy over temperature, is a good choice as a reference source for the DAC121C081. The 4.096V version is useful if a 0 to 4.095V output range is desirable or acceptable. Bypassing the LM4132  $V_{IN}$  pin with a 0.1 $\mu$ F capacitor and the  $V_{OUT}$  pin with a 2.2 $\mu$ F capacitor will improve stability and reduce output noise. The LM4132 comes in a space-saving 5-pin SOT-23.

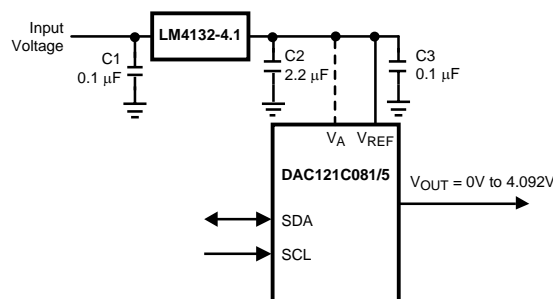

**Figure 27. The LM4132 as a power supply**

**LM4050**

Available with accuracy of 0.44%, the LM4050 shunt reference is also a good choice as a reference for the DAC121C081. It is available in 4.096V and 5V versions and comes in a space-saving 3-pin SOT-23.

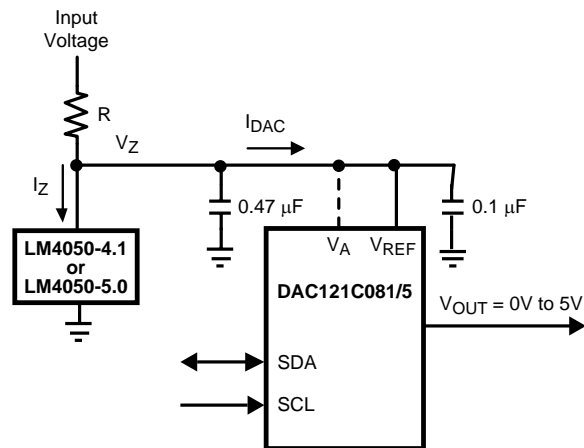

Figure 28. The LM4050 as a power supply

The minimum resistor value in the circuit of Figure 28 must be chosen such that the maximum current through the LM4050 does not exceed its 15 mA rating. The conditions for maximum current include the input voltage at its maximum, the LM4050 voltage at its minimum, and the DAC121C081 drawing zero current. The maximum resistor value must allow the LM4050 to draw more than its minimum current for regulation plus the maximum DAC121C081 current in full operation. The conditions for minimum current include the input voltage at its minimum, the LM4050 voltage at its maximum, the resistor value at its maximum due to tolerance, and the DAC121C081 draws its maximum current. These conditions can be summarized as

$$R(\min) = (V_{IN}(\max) - V_Z(\min)) / I_Z(\max) \quad (3)$$

and

$$R(\max) = (V_{IN}(\min) - V_Z(\max)) / (I_{DAC}(\max) + I_Z(\min)) \quad (4)$$

where  $V_Z(\min)$  and  $V_Z(\max)$  are the nominal LM4050 output voltages  $\pm$  the LM4050 output tolerance over temperature,  $I_Z(\max)$  is the maximum allowable current through the LM4050,  $I_Z(\min)$  is the minimum current required by the LM4050 for proper regulation, and  $I_{DAC}(\max)$  is the maximum DAC121C081 supply current.

### LP3985

The LP3985 is a low noise, ultra low dropout voltage regulator with a 3% accuracy over temperature. It is a good choice for applications that do not require a precision reference for the DAC121C081. It comes in 3.0V, 3.3V and 5V versions, among others, and sports a low 30  $\mu$ V noise specification at low frequencies. Since low frequency noise is relatively difficult to filter, this specification could be important for some applications. The LP3985 comes in a space-saving 5-pin SOT-23 and 5-bump DSBGA packages.

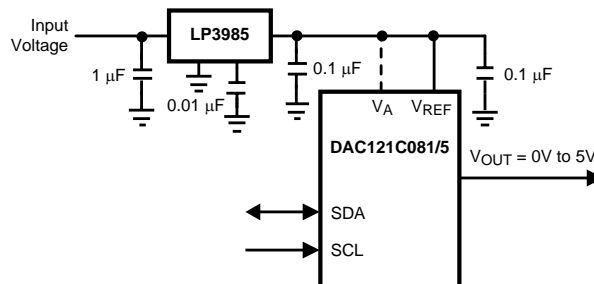
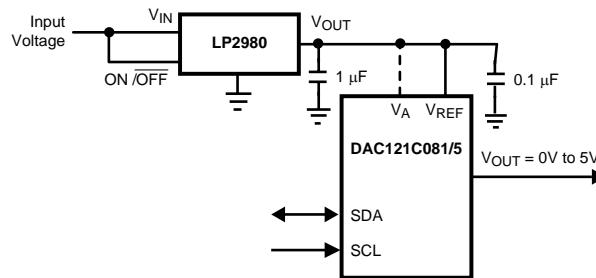

Figure 29. Using the LP3985 regulator

An input capacitance of 1.0 $\mu$ F without any ESR requirement is required at the LP3985 input, while a 1.0 $\mu$ F ceramic capacitor with an ESR requirement of 5m $\Omega$  to 500m $\Omega$  is required at the output. Careful interpretation and understanding of the capacitor specification is required to ensure correct device operation.

**LP2980**

The LP2980 is an ultra low dropout regulator with a 0.5% or 1.0% accuracy over temperature, depending upon grade. It is available in 3.0V, 3.3V and 5V versions, among others.

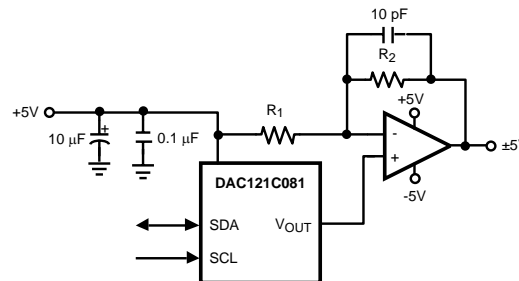

**Figure 30. Using the LP2980 regulator**

Like any low dropout regulator, the LP2980 requires an output capacitor for loop stability. This output capacitor must be at least 1.0µF over temperature, but values of 2.2µF or more will provide even better performance. The ESR of this capacitor should be within the range specified in the LP2980 data sheet. Surface-mount solid tantalum capacitors offer a good combination of small size and ESR. Ceramic capacitors are attractive due to their small size but generally have ESR values that are too low for use with the LP2980. Aluminum electrolytic capacitors are typically not a good choice due to their large size and have ESR values that may be too high at low temperatures.

**BIPOLAR OPERATION**

The DAC121C081 is designed for single supply operation and thus has a unipolar output. However, a bipolar output may be obtained with the circuit in [Figure 31](#). This circuit will provide an output voltage range of ±5 Volts. A rail-to-rail amplifier should be used if the amplifier supplies are limited to ±5V.



**Figure 31. Bipolar Operation**

The output voltage of this circuit for any code is found to be

$$V_O = (V_A \times (D / 4096) \times ((R_1 + R_2) / R_1) - V_A \times R_2 / R_1) \tag{5}$$

where D is the input code in decimal form. With  $V_A = 5V$  and  $R_1 = R_2$ ,

$$V_O = (10 \times D / 4096) - 5V \tag{6}$$

A list of rail-to-rail amplifiers suitable for this application are indicated in [Table 2](#).

**Table 2. Some Rail-to-Rail Amplifiers**

AMP	PKGS	Typ V <sub>OS</sub>	Typ I <sub>SUPPLY</sub>
LMP7701	SOT-23	37 µV	0.79 mA
LMV841	SC70-5	50 µV	1 mA
LMC7111	SOT-23	0.9 mV	25 µA
LM7301	SO-8, SOT-23	0.03 mV	620 µA
LM8261	SOT-23	0.7 mV	1 mA



## DSP/MICROPROCESSOR INTERFACING

Interfacing the DAC121C081 to microprocessors and DSPs is quite simple. The following guidelines are offered to simplify the design process.

### Interfacing to the 2-wire Bus

Figure 32 shows a microcontroller interfacing to the DAC121C081 via the 2-wire bus. Pull-up resistors ( $R_p$ ) should be chosen to create an appropriate bus rise time and to limit the current that will be sunk by the open-drain outputs of the devices on the bus. Please refer to the I<sup>2</sup>C<sup>®</sup> Specification for further details. Typical pull-up values to use in Standard-Fast mode bus applications are 2k $\Omega$  to 10k $\Omega$ . SCL and SDA series resistors ( $R_s$ ) near the DAC121C081 are optional. If high-voltage spikes are expected on the 2-wire bus, series resistors should be used to filter the voltage on SDA and SCL. The value of the series resistance must be picked to ensure the  $V_{IL}$  threshold can be achieved. If used,  $R_s$  is typically 51 $\Omega$ .

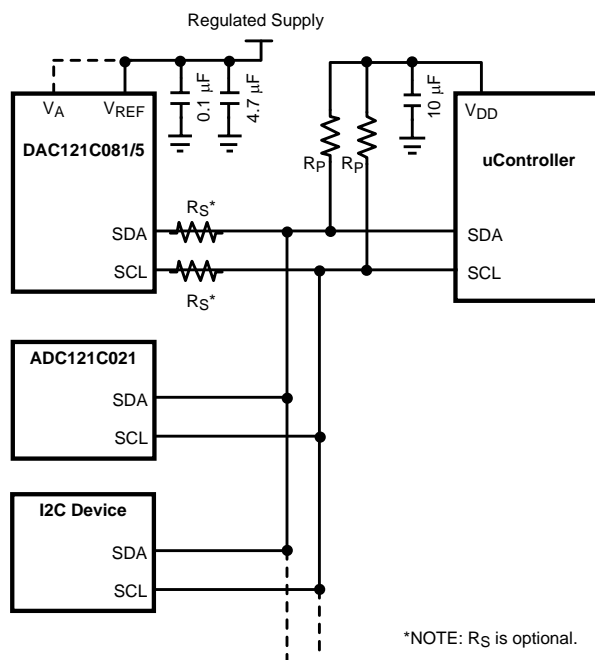

Figure 32. Serial Interface Connection Diagram

### Interfacing to a Hs-mode Bus

Interfacing to a Hs-mode bus is very similar to interfacing to a Standard-Fast mode bus. In Hs-mode, the specified rise time of SCL is shortened. To create a faster rise time, the master device (microcontroller) can drive the SCL bus high and low. In other words, the microcontroller can drive the line high rather than leaving it to the pull-up resistor. It is also possible to decrease the value of the pull-up resistors or increase the pull-up current to meet the tighter timing specs. Please refer to the I<sup>2</sup>C<sup>®</sup> Specification for further details.

## LAYOUT, GROUNDING, AND BYPASSING

For best accuracy and minimum noise, the printed circuit board containing the DAC121C081 should have separate analog and digital areas. The areas are defined by the locations of the analog and digital power planes. Both of these planes should be located on the same board layer. There should be a single ground plane. A single ground plane is preferred if digital return current does not flow through the analog ground area. Frequently a single ground plane design will utilize a "fencing" technique to prevent the mixing of analog and digital ground current. Separate ground planes should only be utilized when the fencing technique is inadequate. The separate ground planes must be connected in one place, preferably near the DAC121C081. Special care is required to ensure that digital signals with fast edge rates do not pass over split ground planes. They must always have a continuous return path below their traces.

The DAC121C081 power supply should be bypassed with a 4.7 $\mu$ F and a 0.1 $\mu$ F capacitor as close as possible to the device with the 0.1 $\mu$ F right at the device supply pin. The 4.7 $\mu$ F capacitor should be a tantalum type and the 0.1 $\mu$ F capacitor should be a low ESL, low ESR type. The power supply for the DAC121C081 should only be used for analog circuits.

Avoid crossover of analog and digital signals and keep the clock and data lines on the component side of the board. These clock and data lines should have controlled impedances.

---

**REVISION HISTORY**

<b>Changes from Revision C (March 2013) to Revision D</b>	<b>Page</b>
<hr/> <ul style="list-style-type: none"><li>• Changed layout of National Data Sheet to TI format .....</li></ul> <hr/>	<hr/> <a href="#">24</a> <hr/>

**PACKAGING INFORMATION**

Orderable Device	Status (1)	Package Type	Package Drawing	Pins	Package Qty	Eco Plan (2)	Lead/Ball Finish	MSL Peak Temp (3)	Op Temp (°C)	Device Marking (4/5)	Samples
DAC121C081CIMK/NOPB	ACTIVE	SOT	DDC	6	1000	Green (RoHS & no Sb/Br)	CU NIPDAU	Level-1-260C-UNLIM	-40 to 125	X84C	<a href="#">Samples</a>
DAC121C081CIMKX/NOPB	ACTIVE	SOT	DDC	6	3000	Green (RoHS & no Sb/Br)	CU NIPDAU	Level-1-260C-UNLIM	-40 to 125	X84C	<a href="#">Samples</a>
DAC121C081CISD/NOPB	ACTIVE	WSON	NGF	6	1000	Green (RoHS & no Sb/Br)	CU SN	Level-1-260C-UNLIM	-40 to 125	X87	<a href="#">Samples</a>
DAC121C081CISDX/NOPB	ACTIVE	WSON	NGF	6	4500	Green (RoHS & no Sb/Br)	CU SN	Level-1-260C-UNLIM	-40 to 125	X87	<a href="#">Samples</a>
DAC121C085CIMM	ACTIVE	VSSOP	DGK	8	1000	TBD	Call TI	Call TI	-40 to 125	X90C	<a href="#">Samples</a>
DAC121C085CIMM/NOPB	ACTIVE	VSSOP	DGK	8	1000	Green (RoHS & no Sb/Br)	CU SN	Level-1-260C-UNLIM	-40 to 125	X90C	<a href="#">Samples</a>
DAC121C085CIMMX/NOPB	ACTIVE	VSSOP	DGK	8	3500	Green (RoHS & no Sb/Br)	CU SN	Level-1-260C-UNLIM	-40 to 125	X90C	<a href="#">Samples</a>

(1) The marketing status values are defined as follows:

**ACTIVE:** Product device recommended for new designs.

**LIFEBUY:** TI has announced that the device will be discontinued, and a lifetime-buy period is in effect.

**NRND:** Not recommended for new designs. Device is in production to support existing customers, but TI does not recommend using this part in a new design.

**PREVIEW:** Device has been announced but is not in production. Samples may or may not be available.

**OBSOLETE:** TI has discontinued the production of the device.

(2) Eco Plan - The planned eco-friendly classification: Pb-Free (RoHS), Pb-Free (RoHS Exempt), or Green (RoHS & no Sb/Br) - please check <http://www.ti.com/productcontent> for the latest availability information and additional product content details.

**TBD:** The Pb-Free/Green conversion plan has not been defined.

**Pb-Free (RoHS):** TI's terms "Lead-Free" or "Pb-Free" mean semiconductor products that are compatible with the current RoHS requirements for all 6 substances, including the requirement that lead not exceed 0.1% by weight in homogeneous materials. Where designed to be soldered at high temperatures, TI Pb-Free products are suitable for use in specified lead-free processes.

**Pb-Free (RoHS Exempt):** This component has a RoHS exemption for either 1) lead-based flip-chip solder bumps used between the die and package, or 2) lead-based die adhesive used between the die and leadframe. The component is otherwise considered Pb-Free (RoHS compatible) as defined above.

**Green (RoHS & no Sb/Br):** TI defines "Green" to mean Pb-Free (RoHS compatible), and free of Bromine (Br) and Antimony (Sb) based flame retardants (Br or Sb do not exceed 0.1% by weight in homogeneous material)

(3) MSL, Peak Temp. -- The Moisture Sensitivity Level rating according to the JEDEC industry standard classifications, and peak solder temperature.

(4) There may be additional marking, which relates to the logo, the lot trace code information, or the environmental category on the device.

<sup>(5)</sup> Multiple Device Markings will be inside parentheses. Only one Device Marking contained in parentheses and separated by a "-" will appear on a device. If a line is indented then it is a continuation of the previous line and the two combined represent the entire Device Marking for that device.

**Important Information and Disclaimer:** The information provided on this page represents TI's knowledge and belief as of the date that it is provided. TI bases its knowledge and belief on information provided by third parties, and makes no representation or warranty as to the accuracy of such information. Efforts are underway to better integrate information from third parties. TI has taken and continues to take reasonable steps to provide representative and accurate information but may not have conducted destructive testing or chemical analysis on incoming materials and chemicals. TI and TI suppliers consider certain information to be proprietary, and thus CAS numbers and other limited information may not be available for release.

In no event shall TI's liability arising out of such information exceed the total purchase price of the TI part(s) at issue in this document sold by TI to Customer on an annual basis.

**TAPE AND REEL INFORMATION**

**QUADRANT ASSIGNMENTS FOR PIN 1 ORIENTATION IN TAPE**

\*All dimensions are nominal

Device	Package Type	Package Drawing	Pins	SPQ	Reel Diameter (mm)	Reel Width W1 (mm)	A0 (mm)	B0 (mm)	K0 (mm)	P1 (mm)	W (mm)	Pin1 Quadrant
DAC121C081CIMK/NOPB	SOT	DDC	6	1000	178.0	8.4	3.2	3.2	1.4	4.0	8.0	Q3
DAC121C081CIMKX/NOPB	SOT	DDC	6	3000	178.0	8.4	3.2	3.2	1.4	4.0	8.0	Q3
DAC121C081CISD/NOPB	WSON	NGF	6	1000	178.0	12.4	2.8	2.5	1.0	8.0	12.0	Q1
DAC121C081CISDX/NOPB	WSON	NGF	6	4500	330.0	12.4	2.8	2.5	1.0	8.0	12.0	Q1
DAC121C085CIMM	VSSOP	DGK	8	1000	178.0	12.4	5.3	3.4	1.4	8.0	12.0	Q1
DAC121C085CIMM/NOPB	VSSOP	DGK	8	1000	178.0	12.4	5.3	3.4	1.4	8.0	12.0	Q1
DAC121C085CIMMX/NOPB	VSSOP	DGK	8	3500	330.0	12.4	5.3	3.4	1.4	8.0	12.0	Q1

**TAPE AND REEL BOX DIMENSIONS**

\*All dimensions are nominal

Device	Package Type	Package Drawing	Pins	SPQ	Length (mm)	Width (mm)	Height (mm)
DAC121C081CIMK/NOPB	SOT	DDC	6	1000	210.0	185.0	35.0
DAC121C081CIMKX/NOP B	SOT	DDC	6	3000	210.0	185.0	35.0
DAC121C081CISD/NOPB	WSON	NGF	6	1000	210.0	185.0	35.0
DAC121C081CISDX/NOP B	WSON	NGF	6	4500	367.0	367.0	35.0
DAC121C085CIMM	VSSOP	DGK	8	1000	210.0	185.0	35.0
DAC121C085CIMM/NOPB	VSSOP	DGK	8	1000	210.0	185.0	35.0
DAC121C085CIMMX/NOP B	VSSOP	DGK	8	3500	367.0	367.0	35.0



DGK (S-PDSO-G8)

PLASTIC SMALL-OUTLINE PACKAGE



4073329/E 05/06

- NOTES:
- A. All linear dimensions are in millimeters.
  - B. This drawing is subject to change without notice.
  - C. Body length does not include mold flash, protrusions, or gate burrs. Mold flash, protrusions, or gate burrs shall not exceed 0.15 per end.
  - D. Body width does not include interlead flash. Interlead flash shall not exceed 0.50 per side.
  - E. Falls within JEDEC MO-187 variation AA, except interlead flash.

DDC (R-PDSO-G6)

PLASTIC SMALL-OUTLINE

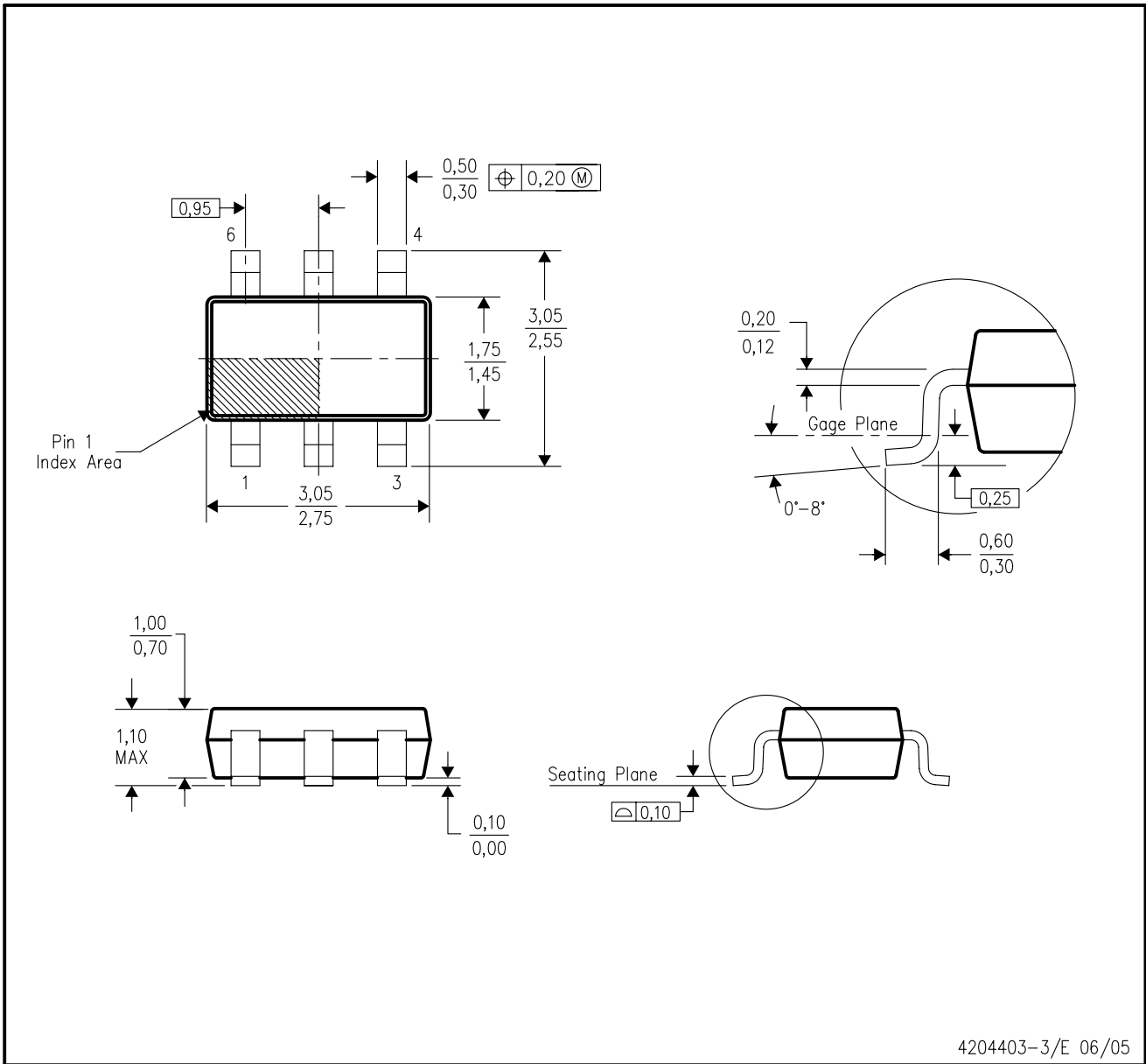

- NOTES:
- A. All linear dimensions are in millimeters.
  - B. This drawing is subject to change without notice.
  - C. Body dimensions do not include mold flash or protrusion.
  - D. Falls within JEDEC MO-193 variation AA (6 pin).

DDC (R-PDSO-G6)

PLASTIC SMALL OUTLINE

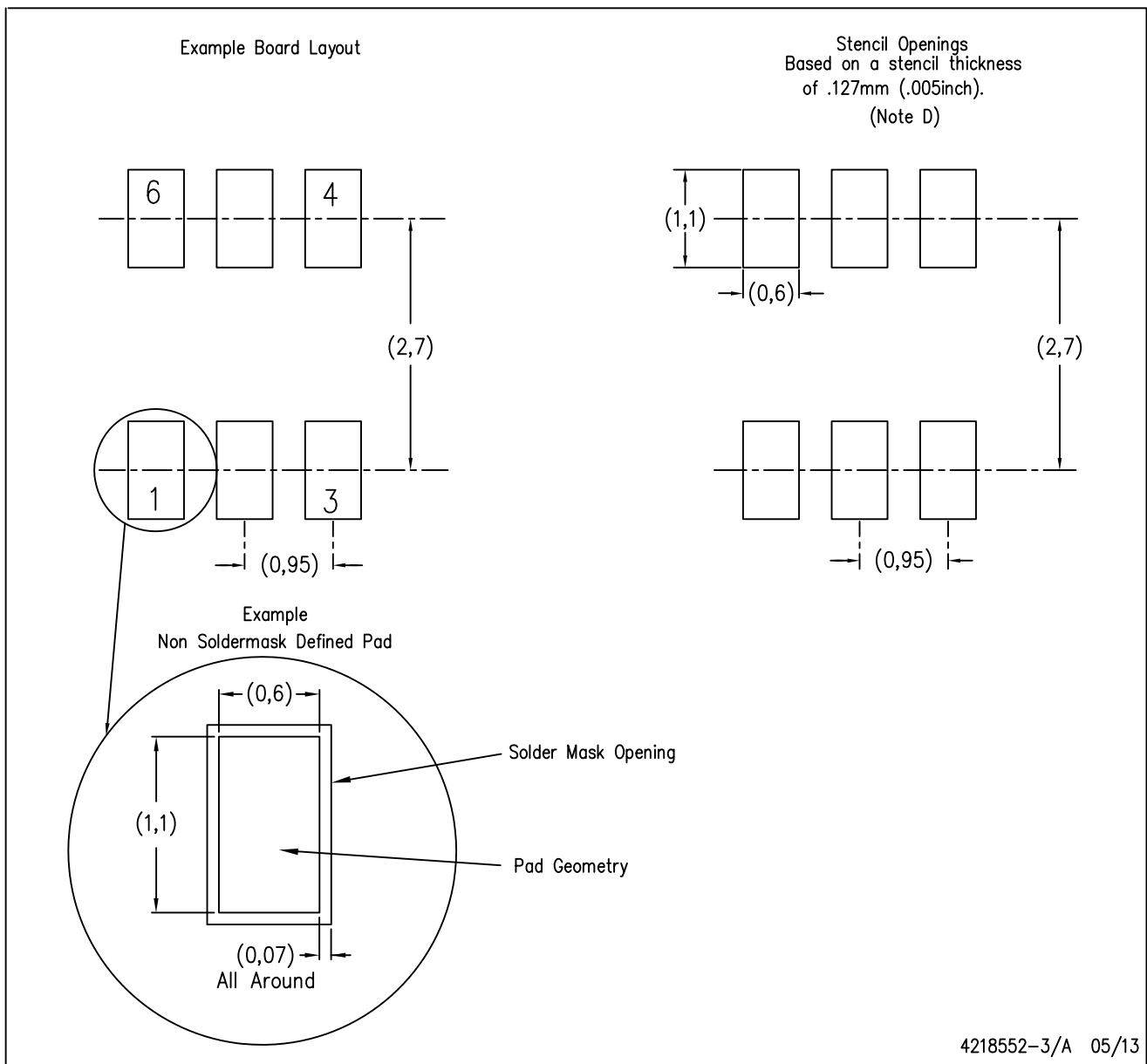

- NOTES:
- A. All linear dimensions are in millimeters.
  - B. This drawing is subject to change without notice.
  - C. Publication IPC-7351 is recommended for alternate designs.
  - D. Laser cutting apertures with trapezoidal walls and also rounding corners will offer better paste release. Customers should contact their board assembly site for stencil design recommendations. Example stencil design based on a 50% volumetric metal load solder paste. Refer to IPC-7525 for other stencil recommendations.

NGF0006A

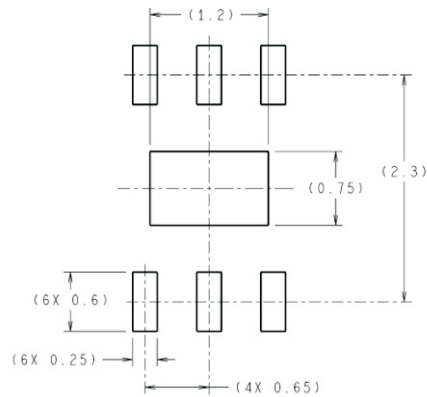

DIMENSIONS ARE IN MILLIMETERS  
DIMENSIONS IN ( ) FOR REFERENCE ONLY

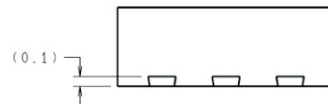

RECOMMENDED LAND PATTERN

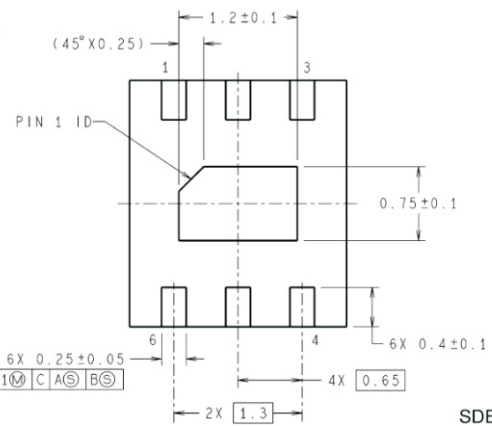
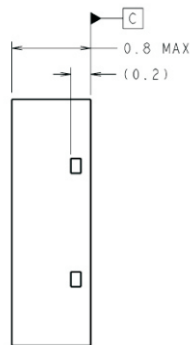
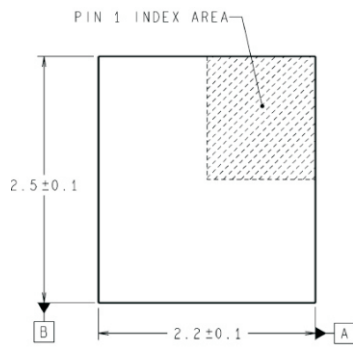

SDB06A (Rev A)

## IMPORTANT NOTICE

Texas Instruments Incorporated and its subsidiaries (TI) reserve the right to make corrections, enhancements, improvements and other changes to its semiconductor products and services per JESD46, latest issue, and to discontinue any product or service per JESD48, latest issue. Buyers should obtain the latest relevant information before placing orders and should verify that such information is current and complete. All semiconductor products (also referred to herein as "components") are sold subject to TI's terms and conditions of sale supplied at the time of order acknowledgment.

TI warrants performance of its components to the specifications applicable at the time of sale, in accordance with the warranty in TI's terms and conditions of sale of semiconductor products. Testing and other quality control techniques are used to the extent TI deems necessary to support this warranty. Except where mandated by applicable law, testing of all parameters of each component is not necessarily performed.

TI assumes no liability for applications assistance or the design of Buyers' products. Buyers are responsible for their products and applications using TI components. To minimize the risks associated with Buyers' products and applications, Buyers should provide adequate design and operating safeguards.

TI does not warrant or represent that any license, either express or implied, is granted under any patent right, copyright, mask work right, or other intellectual property right relating to any combination, machine, or process in which TI components or services are used. Information published by TI regarding third-party products or services does not constitute a license to use such products or services or a warranty or endorsement thereof. Use of such information may require a license from a third party under the patents or other intellectual property of the third party, or a license from TI under the patents or other intellectual property of TI.

Reproduction of significant portions of TI information in TI data books or data sheets is permissible only if reproduction is without alteration and is accompanied by all associated warranties, conditions, limitations, and notices. TI is not responsible or liable for such altered documentation. Information of third parties may be subject to additional restrictions.

Resale of TI components or services with statements different from or beyond the parameters stated by TI for that component or service voids all express and any implied warranties for the associated TI component or service and is an unfair and deceptive business practice. TI is not responsible or liable for any such statements.

Buyer acknowledges and agrees that it is solely responsible for compliance with all legal, regulatory and safety-related requirements concerning its products, and any use of TI components in its applications, notwithstanding any applications-related information or support that may be provided by TI. Buyer represents and agrees that it has all the necessary expertise to create and implement safeguards which anticipate dangerous consequences of failures, monitor failures and their consequences, lessen the likelihood of failures that might cause harm and take appropriate remedial actions. Buyer will fully indemnify TI and its representatives against any damages arising out of the use of any TI components in safety-critical applications.

In some cases, TI components may be promoted specifically to facilitate safety-related applications. With such components, TI's goal is to help enable customers to design and create their own end-product solutions that meet applicable functional safety standards and requirements. Nonetheless, such components are subject to these terms.

No TI components are authorized for use in FDA Class III (or similar life-critical medical equipment) unless authorized officers of the parties have executed a special agreement specifically governing such use.

Only those TI components which TI has specifically designated as military grade or "enhanced plastic" are designed and intended for use in military/aerospace applications or environments. Buyer acknowledges and agrees that any military or aerospace use of TI components which have **not** been so designated is solely at the Buyer's risk, and that Buyer is solely responsible for compliance with all legal and regulatory requirements in connection with such use.

TI has specifically designated certain components as meeting ISO/TS16949 requirements, mainly for automotive use. In any case of use of non-designated products, TI will not be responsible for any failure to meet ISO/TS16949.

### Products

Audio	<a href="http://www.ti.com/audio">www.ti.com/audio</a>
Amplifiers	<a href="http://amplifier.ti.com">amplifier.ti.com</a>
Data Converters	<a href="http://dataconverter.ti.com">dataconverter.ti.com</a>
DLP® Products	<a href="http://www.dlp.com">www.dlp.com</a>
DSP	<a href="http://dsp.ti.com">dsp.ti.com</a>
Clocks and Timers	<a href="http://www.ti.com/clocks">www.ti.com/clocks</a>
Interface	<a href="http://interface.ti.com">interface.ti.com</a>
Logic	<a href="http://logic.ti.com">logic.ti.com</a>
Power Mgmt	<a href="http://power.ti.com">power.ti.com</a>
Microcontrollers	<a href="http://microcontroller.ti.com">microcontroller.ti.com</a>
RFID	<a href="http://www.ti-rfid.com">www.ti-rfid.com</a>
OMAP Applications Processors	<a href="http://www.ti.com/omap">www.ti.com/omap</a>
Wireless Connectivity	<a href="http://www.ti.com/wirelessconnectivity">www.ti.com/wirelessconnectivity</a>

### Applications

Automotive and Transportation	<a href="http://www.ti.com/automotive">www.ti.com/automotive</a>
Communications and Telecom	<a href="http://www.ti.com/communications">www.ti.com/communications</a>
Computers and Peripherals	<a href="http://www.ti.com/computers">www.ti.com/computers</a>
Consumer Electronics	<a href="http://www.ti.com/consumer-apps">www.ti.com/consumer-apps</a>
Energy and Lighting	<a href="http://www.ti.com/energy">www.ti.com/energy</a>
Industrial	<a href="http://www.ti.com/industrial">www.ti.com/industrial</a>
Medical	<a href="http://www.ti.com/medical">www.ti.com/medical</a>
Security	<a href="http://www.ti.com/security">www.ti.com/security</a>
Space, Avionics and Defense	<a href="http://www.ti.com/space-avionics-defense">www.ti.com/space-avionics-defense</a>
Video and Imaging	<a href="http://www.ti.com/video">www.ti.com/video</a>

### TI E2E Community

[e2e.ti.com](http://e2e.ti.com)