



**ADVANCE**

**CYW4356**

**Single-Chip 5G WiFi IEEE 802.11ac 2×2 MAC/  
Baseband/Radio with Integrated Bluetooth 4.1,  
FM Receiver, and Wireless Charging**

The Cypress CYW4356 is a complete dual-band (2.4 GHz and 5 GHz) 5G WiFi 2 × 2 MIMO MAC/PHY/Radio System-on-a-Chip. This Wi-Fi single-chip device provides a high level of integration with dual-stream IEEE 802.11ac MAC/baseband/radio, Bluetooth 4.1, and FM radio receiver. Additionally, it supports wireless charging. In IEEE 802.11ac mode, the WLAN operation supports rates of MCS0–MCS9 (up to 256 QAM) in 20 MHz, 40 MHz, and 80 MHz channels for data rates up to 867 Mbps. In addition, all the rates specified in IEEE 802.11a/b/g/n are supported. Included on-chip are 2.4 GHz and 5 GHz transmit power amplifiers and receive low noise amplifiers.

For the WLAN section, several alternative host interface options are included: an SDIO v3.0 interface that can operate in 4b or 1b modes, and a PCIe v3.0 compliant interface running at Gen1 speeds. For the Bluetooth section, host interface options of a high-speed 4-wire UART and USB 2.0 full-speed (12 Mbps) are provided.

The CYW4356 uses advanced design techniques and process technology to reduce active and idle power, and includes an embedded power management unit that simplifies the system power topology.

In addition, the CYW4356 implements highly sophisticated enhanced collaborative coexistence hardware mechanisms and algorithms that ensure that WLAN and Bluetooth collaboration is optimized for maximum performance. Coexistence support for external radios (such as LTE cellular and GPS) is provided via an external interface. As a result, enhanced overall quality for simultaneous voice, video, and data transmission on a handheld system is achieved.

This data sheet provides details on the functional, operational, and electrical characteristics for the Cypress CYW4356. It is intended for hardware design, application, and OEM engineers.

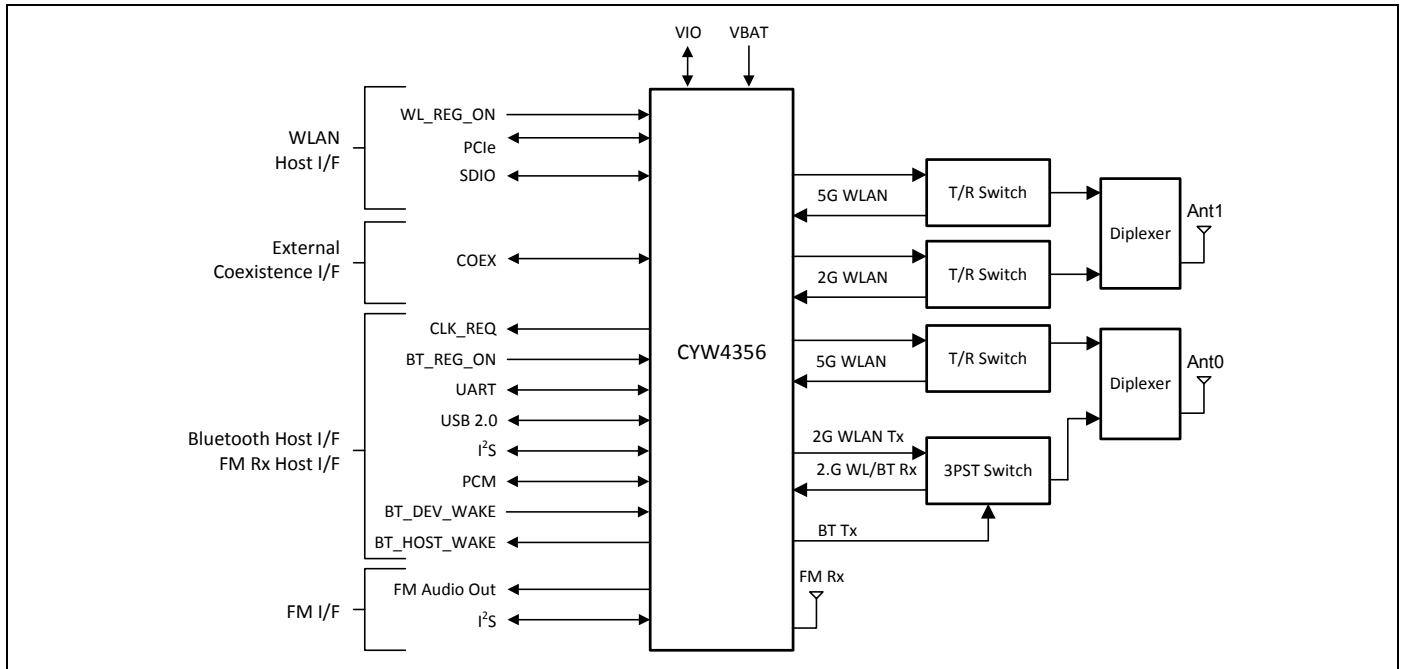
**Cypress Part Numbering Scheme**

Cypress is converting the acquired IoT part numbers from Broadcom to the Cypress part numbering scheme. Due to this conversion, there is no change in form, fit, or function as a result of offering the device with Cypress part number marking. The table provides Cypress ordering part number that matches an existing IoT part number.

**Table 1. Mapping Table for Part Number between Broadcom and Cypress**

Broadcom Part Number	Cypress Part Number
BCM4356	CYW4356
BCM4330	CYW4330
BCM4356XKUBG	CYW4356XKUBG
BCM4356XKWBG	CYW4356XKWBG

**Figure 1. Functional Block Diagram**



## Features

### IEEE 802.11X Key Features

- IEEE 802.11ac Draft compliant.
- Dual-stream spatial multiplexing up to 867 Mbps data rate.
- Supports 20, 40, and 80 MHz channels with optional SGI (256 QAM modulation).
- Full IEEE 802.11a/b/g/n legacy compatibility with enhanced performance.
- TX and RX low-density parity check (LDPC) support for improved range and power efficiency.
- Supports IEEE 802.11ac/n beamforming.
- On-chip power amplifiers and low-noise amplifiers for both bands.
- Supports various RF front-end architectures including:
  - Two antennas with one each dedicated to Bluetooth and WLAN.
  - Two antennas with WLAN diversity and a shared Bluetooth antenna.
- Shared Bluetooth and WLAN receive signal path eliminates the need for an external power splitter while maintaining excellent sensitivity for both Bluetooth and WLAN.
- Internal fractional nPLL allows support for a wide range of reference clock frequencies.
- Supports IEEE 802.15.2 external coexistence interface to optimize bandwidth utilization with other co-located wireless technologies such as LTE or GPS.
- Supports standard SDIO v3.0 (up to SDR104 mode at 208 MHz, 4-bit and 1-bit) host interfaces.
- Backward compatible with SDIO v2.0 host interfaces.
- PCIe mode complies with PCI Express base specification revision 3.0 for ×1 lane and power management running at Gen1 speeds.
- Supports Active State Power Management (ASPM).
- Integrated ARMCR4 processor with tightly coupled memory for complete WLAN subsystem functionality, minimizing the need to wake up the applications processor for standard WLAN functions. This allows for further minimization of power consumption, while maintaining the ability to field upgrade with future features. On-chip memory includes 768 KB SRAM and 640 KB ROM.
- OneDriver™ software architecture for easy migration from existing embedded WLAN and Bluetooth devices as well as future devices.
- Supports A4WP wireless charging with the BCM59350.

### Bluetooth and FM Key Features

- Complies with Bluetooth Core Specification Version 4.1 with provisions for supporting future specifications.
- Bluetooth Class 1 or Class 2 transmitter operation.
- Supports extended synchronous connections (eSCO), for enhanced voice quality by allowing for retransmission of dropped packets.
- Adaptive frequency hopping (AFH) for reducing radio frequency interference.
- Interface support, host controller interface (HCI) using a USB or high-speed UART interface and PCM for audio data.
- USB 2.0 full-speed (12 Mbps) supported for Bluetooth.
- The FM unit supports HCI for communication.
- Low power consumption improves battery life of handheld devices.
- FM receiver: 65 MHz to 108 MHz FM bands; supports the European radio data systems (RDS) and the North American radio broadcast data system (RBDS) standards.
- Supports multiple simultaneous Advanced Audio Distribution Profiles (A2DP) for stereo sound.
- Automatic frequency detection for standard crystal and TCXO values.

### General Features

- Supports battery range from 3.0V to 5.25V supplies with internal switching regulator
- Programmable dynamic power management
- 484 bytes of user-accessible OTP for storing board parameters
- GPIOs: 11 in WLBGA, 16 in WLCSP
- Package options:
  - 192-ball WLBGA (4.87 mm × 7.67 mm, 0.4 mm pitch)
  - 395-bump WLCSP (4.87 mm × 7.67 mm, 0.2 mm pitch)
- Security:
  - WPA and WPA2 (Personal) support for powerful encryption and authentication
  - AES and TKIP in hardware for faster data encryption and IEEE 802.11i compatibility
  - Reference WLAN subsystem provides Cisco Compatible Extensions (CCX, CCX 2.0, CCX 3.0, CCX 4.0, CCX 5.0)
  - Reference WLAN subsystem provides Wi-Fi Protected Setup (WPS)
- Worldwide regulatory support: Global products supported with worldwide homologated design.

**Contents**

<b>1. Overview</b> .....	<b>6</b>	9.6 JTAG Interface .....	48
1.1 Overview .....	6	9.7 SPROM Interface .....	48
1.2 Features .....	8	<b>10. WLAN Host Interfaces</b> .....	<b>49</b>
1.3 Standards Compliance .....	9	10.1 SDIO v3.0 .....	49
<b>2. Power Supplies and Power Management</b> .....	<b>10</b>	10.2 PCI Express Interface .....	51
2.1 Power Supply Topology .....	10	<b>11. Wireless LAN MAC and PHY</b> .....	<b>53</b>
2.2 CYW4356 PMU Features .....	10	11.1 IEEE 802.11ac Draft MAC .....	53
2.3 WLAN Power Management .....	12	11.2 IEEE 802.11ac Draft PHY .....	55
2.4 PMU Sequencing .....	12	<b>12. WLAN Radio Subsystem</b> .....	<b>57</b>
2.5 Power-Off Shutdown .....	13	12.1 Receiver Path .....	59
2.6 Power-Up/Power-Down/Reset Circuits .....	13	12.2 Transmit Path .....	59
2.7 Wireless Charging .....	13	12.3 Calibration .....	59
<b>3. Frequency References</b> .....	<b>16</b>	<b>13. Pin Information</b> .....	<b>60</b>
3.1 Crystal Interface and Clock Generation .....	16	13.1 Ball Maps .....	60
3.2 External Frequency Reference .....	16	13.2 Pin Lists .....	61
3.3 External 32.768 kHz Low-Power Oscillator .....	18	13.3 Signal Descriptions .....	77
<b>4. Bluetooth + FM Subsystem Overview</b> .....	<b>19</b>	13.4 WLAN/BT GPIO Signals and Strapping Options	90
4.1 Features .....	19	13.5 GPIO Alternative Signal Functions .....	91
4.2 Bluetooth Radio .....	20	13.6 I/O States .....	93
<b>5. Bluetooth Baseband Core</b> .....	<b>22</b>	<b>14. DC Characteristics</b> .....	<b>96</b>
5.1 Bluetooth 4.1 Features .....	22	14.1 Absolute Maximum Ratings .....	96
5.2 Bluetooth Low Energy .....	22	14.2 Environmental Ratings .....	96
5.3 Link Control Layer .....	22	14.3 Electrostatic Discharge Specifications .....	96
5.4 Test Mode Support .....	23	14.4 Recommended Operating Conditions and	DC Characteristics .....
5.5 Bluetooth Power Management Unit .....	23	.....	97
5.6 Adaptive Frequency Hopping .....	26	<b>15. Bluetooth RF Specifications</b> .....	<b>99</b>
5.7 Advanced Bluetooth/WLAN Coexistence .....	26	<b>16. FM Receiver Specifications</b> .....	<b>105</b>
5.8 Fast Connection (Interlaced Page and Inquiry	Scans) .....	<b>17. WLAN RF Specifications</b> .....	<b>109</b>
.....	26	17.1 Introduction .....	109
<b>6. Microprocessor and Memory Unit for Bluetooth</b> .....	<b>27</b>	17.2 2.4 GHz Band General RF Specifications .....	109
6.1 RAM, ROM, and Patch Memory .....	27	17.3 WLAN 2.4 GHz Receiver Performance	Specifications .....
6.2 Reset .....	27	.....	110
<b>7. Bluetooth Peripheral Transport Unit</b> .....	<b>28</b>	17.4 WLAN 2.4 GHz Transmitter Performance	Specifications .....
7.1 SPI Interface .....	28	.....	115
7.2 SPI/UART Transport Detection .....	28	17.5 WLAN 5 GHz Receiver Performance	Specifications .....
7.3 PCM Interface .....	28	.....	117
7.4 USB Interface .....	36	17.6 WLAN 5 GHz Transmitter Performance	Specifications .....
7.5 UART Interface .....	38	.....	123
7.6 I <sup>2</sup> S Interface .....	39	<b>18. Internal Regulator Electrical Specifications</b> .....	<b>124</b>
<b>8. FM Receiver Subsystem</b> .....	<b>42</b>	18.1 Core Buck Switching Regulator .....	124
8.1 FM Radio .....	42	18.2 3.3V LDO (LDO3P3) .....	125
8.2 Digital FM Audio Interfaces .....	42	18.3 3.3V LDO (LDO3P3_B) .....	126
8.3 FM Over Bluetooth .....	42	18.4 2.5V LDO (BTLDO2P5) .....	127
8.4 eSCO .....	42	18.5 CLDO .....	128
8.5 Wideband Speech Link .....	42	18.6 LNLDO .....	129
8.6 A2DP .....	42	<b>19. System Power Consumption</b> .....	<b>130</b>
8.7 Autotune and Search Algorithms .....	42	19.1 WLAN Current Consumption .....	130
8.8 Audio Features .....	43	19.2 Bluetooth and FM Current Consumption .....	132
8.9 RDS/RBDS .....	45	<b>20. Interface Timing and AC Characteristics</b> .....	<b>133</b>
<b>9. WLAN Global Functions</b> .....	<b>46</b>	20.1 SDIO Timing .....	133
9.1 WLAN CPU and Memory Subsystem .....	46	20.2 PCI Express Interface Parameters .....	141
9.2 One-Time Programmable Memory .....	46	20.3 JTAG Timing .....	142
9.3 GPIO Interface .....	46	<b>21. Power-Up Sequence and Timing</b> .....	<b>143</b>
9.4 External Coexistence Interface .....	47	21.1 Sequencing of Reset and Regulator Control	Signals .....
9.5 UART Interface .....	48	.....	143

<b>22. Package Information</b> .....	<b>148</b>	<b>25. Additional Information</b> .....	<b>153</b>
22.1 Package Thermal Characteristics .....	148	25.1 Acronyms and Abbreviations .....	153
22.2 Junction Temperature Estimation and $\Psi_{JT}$ Versus $\Theta_{JC}$ .....	148	25.2 References .....	153
22.3 Environmental Characteristics .....	148	<b>26. IoT Resources</b> .....	<b>153</b>
<b>23. Mechanical Information</b> .....	<b>149</b>	<b>Document History</b> .....	<b>154</b>
<b>24. Ordering Information</b> .....	<b>153</b>	<b>Sales, Solutions, and Legal Information</b> .....	<b>155</b>

## 1. Overview

### 1.1 Overview

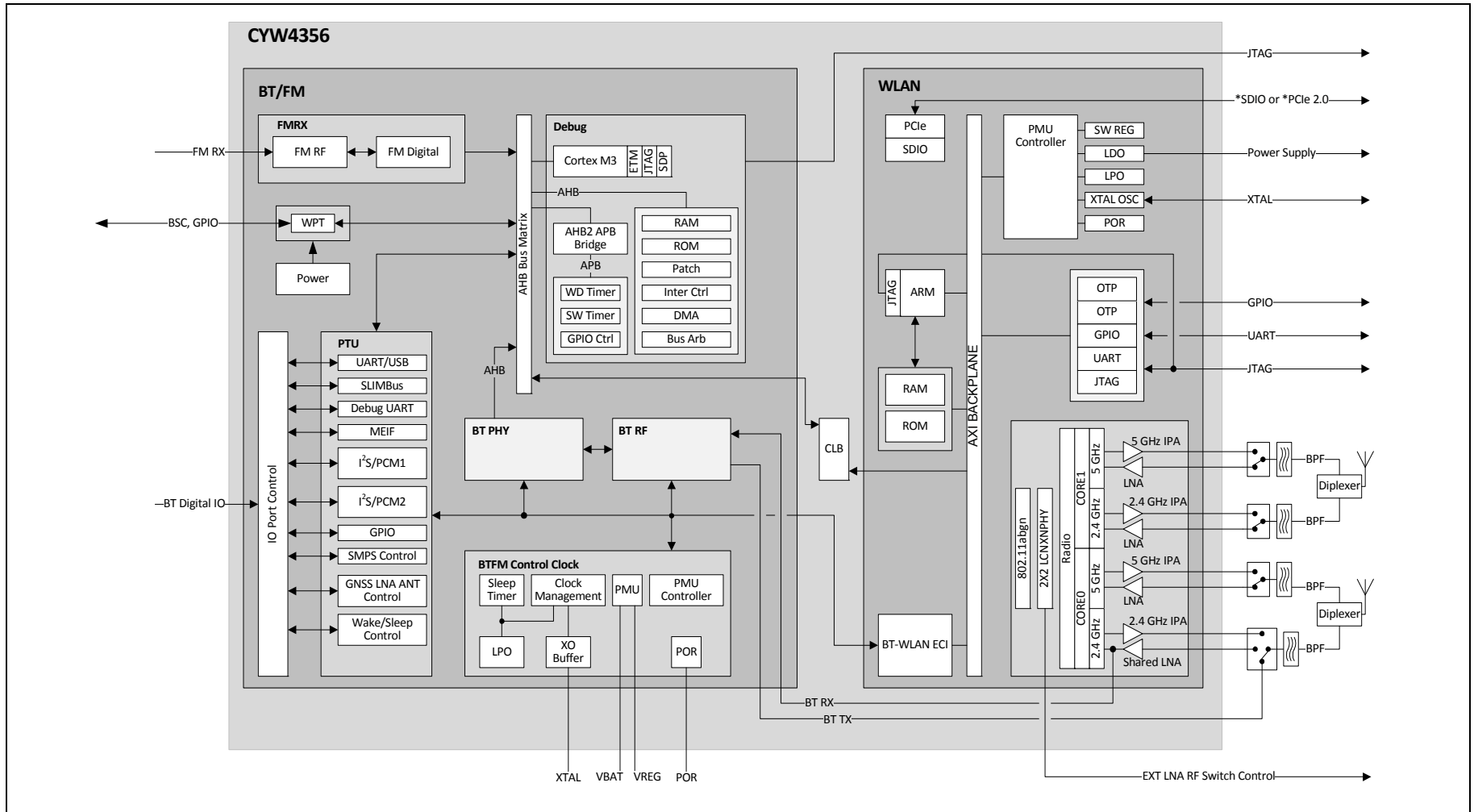
The Cypress CYW4356 single-chip device provides the highest level of integration for a mobile or handheld wireless system, with integrated IEEE 802.11 a/b/g/n/ac MAC/baseband/radio, Bluetooth 4.1 + EDR (enhanced data rate), FM receiver, and Alliance for Wireless Power (A4WP) support. The wireless charging feature works in collaboration with the Wireless Power Transfer (WPT) BCM59350 front-end IC. It provides a small form-factor solution with minimal external components to drive down cost for mass volumes and allows for handheld device flexibility in size, form, and function. Comprehensive power management circuitry and software ensure the system can meet the needs of highly mobile devices that require minimal power consumption and reliable operation.

Figure 2 shows the interconnect of all the major physical blocks in the CYW4356 and their associated external interfaces, which are described in greater detail in the following sections.

**Table 2. Device Options and Features**

Feature	WLPGA	WLCSP
Package ball count	192 pins	395 bumps
PCIe	Yes	Yes
USB2.0 (Bluetooth)	Yes	Yes
I <sup>2</sup> S	Multiplexed onto six parallel Flash pins	No
GPIO	11	16
SDIO 3.0	Yes	Yes
WPT (BSC, GPIO)	Yes	Yes
SPROM	Yes	Yes

Figure 2. CYW4356 Block Diagram



## 1.2 Features

The CYW4356 supports the following features:

- IEEE 802.11a/b/g/n/ac dual-band 2x2 MIMO radio with virtual-simultaneous dual-band operation
- Bluetooth v4.1 + EDR with integrated Class 1 PA
- Concurrent Bluetooth, FM (RX) RDS/RBDS, and WLAN operation
- On-chip WLAN driver execution capable of supporting IEEE 802.11 functionality
- Single- and dual-antenna support
  - Single antenna with shared LNA
  - Simultaneous BT/WLAN receive with single antenna
- WLAN host interface options:
  - SDIO v3.0 (1 bit/4 bit)—up to 208 MHz clock rate in SDR104 mode
  - PCIe v3.0 for x1 lane and power management, running at Gen 1 speeds
- BT host digital interface (can be used concurrently with above interfaces):
  - UART (up to 4 Mbps)
- BT supports full-speed USB 2.0-compliant interface
- ECI—enhanced coexistence support, ability to coordinate BT SCO transmissions around WLAN receives
- I<sup>2</sup>S/PCM for FM/BT audio, HCI for FM block control
- HCI high-speed UART (H4, H4+, H5) transport support
- Wideband speech support (16 bits linear data, MSB first, left justified at 4K samples/s for transparent air coding, both through I<sup>2</sup>S and PCM interface)
- Bluetooth SmartAudio® technology improves voice and music quality to headsets
- Bluetooth low power inquiry and page scan
- Bluetooth Low Energy (BLE) support
- Bluetooth Packet Loss Concealment (PLC)
- Bluetooth Wideband Speech (WBS)
- FM advanced internal antenna support
- FM auto search/tuning functions
- FM multiple audio routing options: I<sup>2</sup>S, PCM, eSCO, and A2DP
- FM mono-stereo blend and switch, and soft mute support
- FM audio pause detect support
- Audio rate-matching algorithms
- Multiple simultaneous A2DP audio stream
- FM over Bluetooth operation and on-chip stereo headset emulation (SBC)
- A4WP support



### 1.3 Standards Compliance

The CYW4356 supports the following standards:

- Bluetooth 2.1 + EDR
- Bluetooth 3.0 + HS
- Bluetooth 4.1 (Bluetooth Low Energy)
- 65 MHz to 108 MHz FM bands (US, Europe, and Japan)
- IEEE802.11ac mandatory and optional requirements for 20 MHz, 40 MHz, and 80 MHz channels
- IEEE 802.11n—Handheld Device Class (Section 11)
- IEEE 802.11a
- IEEE 802.11b
- IEEE 802.11g
- IEEE 802.11d
- IEEE 802.11h
- IEEE 802.11i
- Security:
  - WEP
  - WPA Personal
  - WPA2 Personal
  - WMM
  - WMM-PS (U-APSD)
  - WMM-SA
  - AES (Hardware Accelerator)
  - TKIP (HW Accelerator)
  - CKIP (SW Support)
- Proprietary Protocols:
  - CCXv2
  - CCXv3
  - CCXv4
  - CCXv5
- IEEE 802.15.2 Coexistence Compliance—on silicon solution compliant with IEEE 3 wire requirements

The CYW4356 will support the following future drafts/standards:

- IEEE 802.11r—Fast Roaming (between APs)
- IEEE 802.11w—Secure Management Frames
- A4WP Wireless Power Transfer System Baseline System Specification V1.0
- IEEE 802.11 Extensions:
  - IEEE 802.11e QoS Enhancements (In accordance with the WMM specification, QoS is already supported.)
  - IEEE 802.11h 5 GHz Extensions
  - IEEE 802.11i MAC Enhancements
  - IEEE 802.11k Radio Resource Measurement

## 2. Power Supplies and Power Management

### 2.1 Power Supply Topology

One Buck regulator, multiple LDO regulators, and a power management unit (PMU) are integrated into the CYW4356. All regulators are programmable via the PMU. These blocks simplify power supply design for Bluetooth, WLAN, and FM functions in embedded designs.

A single VBAT (3.0V to 5.25V DC max.) and VIO supply (1.8V to 3.3V) can be used, with all additional voltages being provided by the regulators in the CYW4356.

Two control signals, BT\_REG\_ON and WL\_REG\_ON, are used to power-up the regulators and take the respective section out of reset. The CBUCK CLDO and LNLDO power up when any of the reset signals are deasserted. All regulators are powered down only when both BT\_REG\_ON and WL\_REG\_ON are deasserted. The CLDO and LNLDO may be turned off/on based on the dynamic demands of the digital baseband.

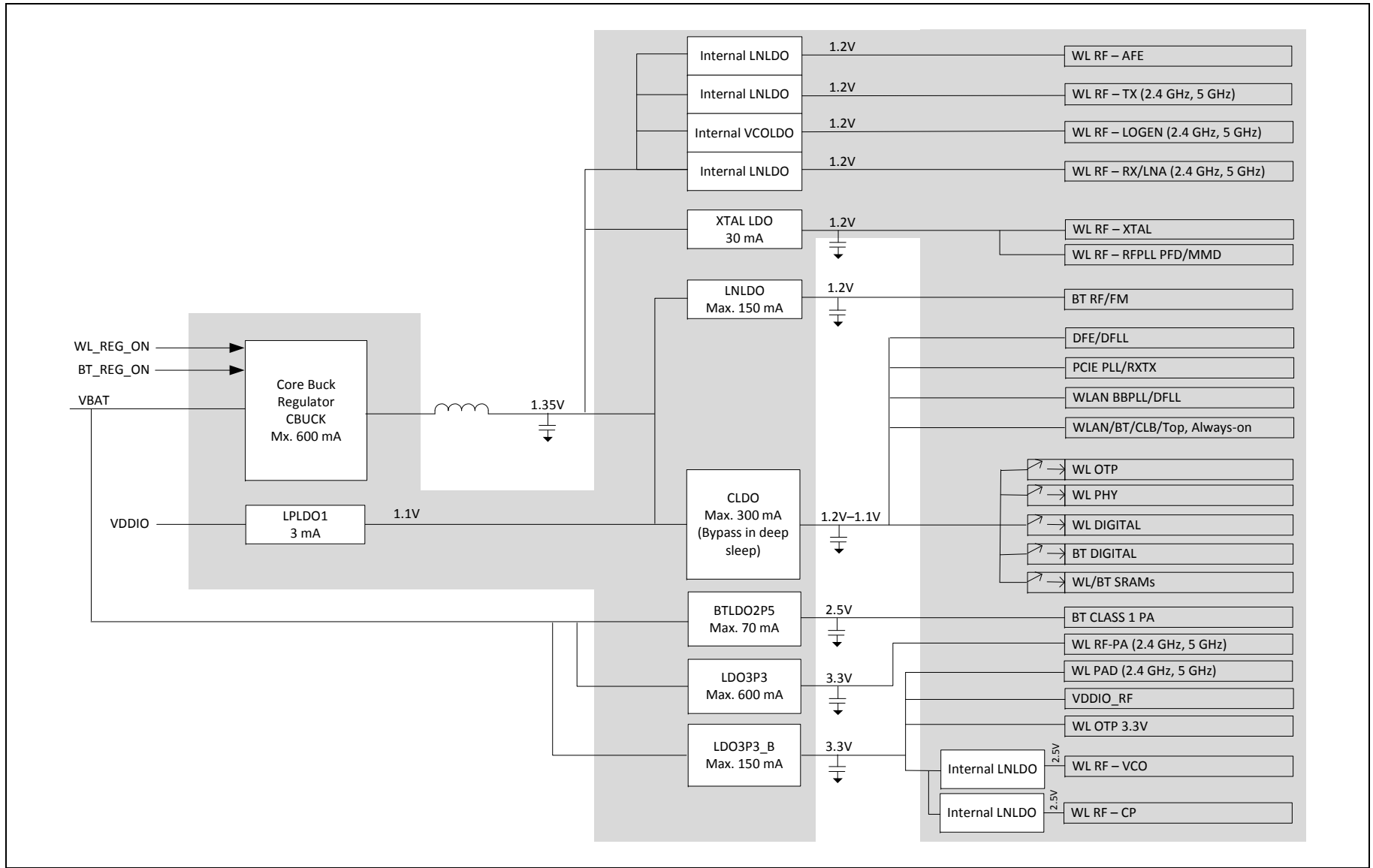
The CYW4356 allows for an extremely low power-consumption mode by completely shutting down the CBUCK, CLDO, and LNLDO regulators. When in this state, LPLDO1 (which is a low-power linear regulator supplied by the system VIO supply) provides the CYW4356 with all the voltages it requires, further reducing leakage currents.

### 2.2 CYW4356 PMU Features

- VBAT to 1.35Vout (600 mA maximum) Core-Buck (CBUCK) switching regulator
- VBAT to 3.3Vout (600 mA maximum) LDO3P3
- VBAT to 3.3Vout (150 mA maximum) LDO3P3\_B
- VBAT to 2.5V out (70 mA maximum) BTLDO2P5
- 1.35V to 1.2Vout (150 mA maximum) LNLDO
- 1.35V to 1.2Vout (300 mA maximum) CLDO with bypass mode for deep-sleep
- Additional internal LDOs (not externally accessible)

Figure 3 illustrates the typical power topology for the CYW4356. The shaded areas are internal to the CYW4356.

**Figure 3. Typical Power Topology for the CYW4356**



### 2.3 WLAN Power Management

The CYW4356 has been designed with the stringent power consumption requirements of mobile devices in mind. All areas of the chip design are optimized to minimize power consumption. Silicon processes and cell libraries were chosen to reduce leakage current and supply voltages. Additionally, the CYW4356 integrated RAM is a high Vt memory with dynamic clock control. The dominant supply current consumed by the RAM is leakage current only. Additionally, the CYW4356 includes an advanced WLAN power management unit (PMU) sequencer. The PMU sequencer provides significant power savings by putting the CYW4356 into various power management states appropriate to the current environment and activities that are being performed. The power management unit enables and disables internal regulators, switches, and other blocks based on a computation of the required resources and a table that describes the relationship between resources and the time needed to enable and disable them. Power up sequences are fully programmable. Configurable, free-running counters (running at 32.768 kHz LPO clock) in the PMU sequencer are used to turn on/turn off individual regulators and power switches. Clock speeds are dynamically changed (or gated altogether) for the current mode. Slower clock speeds are used wherever possible.

The CYW4356 WLAN power states are described as follows:

- **Active mode**—All WLAN blocks in the CYW4356 are powered up and fully functional with active carrier sensing and frame transmission and receiving. All required regulators are enabled and put in the most efficient mode based on the load current. Clock speeds are dynamically adjusted by the PMU sequencer.
- **Deep-sleep mode**—Most of the chip including both analog and digital domains and most of the regulators are powered off. All main clocks (PLL, crystal oscillator, or TCXO) are shut down to reduce active power to the minimum. The 32.768 kHz LPO clock is available only for the PMU sequencer. This condition is necessary to allow the PMU sequencer to wake up the chip and transition to Active mode. Logic states in the digital core are saved and preserved into a retention memory in the always-ON domain before the digital core is powered off. Upon a wake-up event triggered by the PMU timers, an external interrupt or a host resumes through the SDIO bus and logic states in the digital core are restored to their pre-deep-sleep settings to avoid lengthy HW reinitialization. In Deep-sleep mode, the primary source of power consumption is leakage current.
- **Power-down mode**—The CYW4356 is effectively powered off by shutting down all internal regulators. The chip is brought out of this mode by external logic reenabling the internal regulators.

### 2.4 PMU Sequencing

The PMU sequencer is responsible for minimizing system power consumption. It enables and disables various system resources based on a computation of the required resources and a table that describes the relationship between resources and the time needed to enable and disable them.

Resource requests may come from several sources: clock requests from cores, the minimum resources defined in the ResourceMin register, and the resources requested by any active resource request timers. The PMU sequencer maps clock requests into a set of resources required to produce the requested clocks.

Each resource is in one of four states: enabled, disabled, transition\_on, and transition\_off and has a timer that contains 0 when the resource is enabled or disabled and a non-zero value in the transition states. The timer is loaded with the time\_on or time\_off value of the resource when the PMU determines that the resource must be enabled or disabled. That timer decrements on each 32.768 kHz PMU clock. When it reaches 0, the state changes from transition\_off to disabled or transition\_on to enabled. If the time\_on value is 0, the resource can go immediately from disabled to enabled. Similarly, a time\_off value of 0 indicates that the resource can go immediately from enabled to disabled. The terms enable sequence and disable sequence refer to either the immediate transition or the timer load-decrement sequence.

During each clock cycle, the PMU sequencer performs the following actions:

- Computes the required resource set based on requests and the resource dependency table.
- Decrements all timers whose values are non zero. If a timer reaches 0, the PMU clears the ResourcePending bit for the resource and inverts the ResourceState bit.
- Compares the request with the current resource status and determines which resources must be enabled or disabled.
- Initiates a disable sequence for each resource that is enabled, no longer being requested, and has no powered up dependents.
- Initiates an enable sequence for each resource that is disabled, is being requested, and has all of its dependencies enabled.

## 2.5 Power-Off Shutdown

The CYW4356 provides a low-power shutdown feature that allows the device to be turned off while the host, and any other devices in the system, remain operational. When the CYW4356 is not needed in the system, VDDIO\_RF and VDDC are shut down while VBAT and VDDIO remain powered. This allows the CYW4356 to be effectively off while keeping the I/O pins powered so that they do not draw extra current from any other devices connected to the I/O.

During a low-power shut-down state, provided VDDIO remains applied to the CYW4356, all outputs are tristated, and most inputs signals are disabled. Input voltages must remain within the limits defined for normal operation. This is done to prevent current paths or create loading on any digital signals in the system, and enables the CYW4356 to be fully integrated in an embedded device and take full advantage of the lowest power-savings modes.

When the CYW4356 is powered on from this state, it is the same as a normal power-up and the device does not retain any information about its state from before it was powered down.

## 2.6 Power-Up/Power-Down/Reset Circuits

The CYW4356 has two signals (see Table 3) that enable or disable the Bluetooth and WLAN circuits and the internal regulator blocks, allowing the host to control power consumption. For timing diagrams of these signals and the required power-up sequences, see Section 21. Power-Up Sequence and Timing.

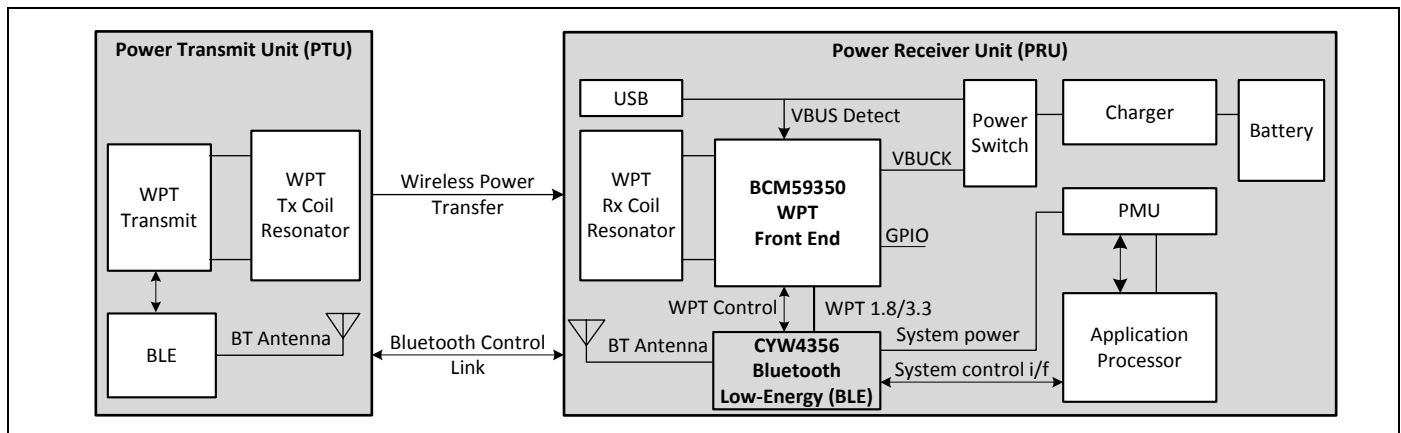
**Table 3. Power-Up/Power-Down/Reset Control Signals**

Signal	Description
WL_REG_ON	This signal is used by the PMU (with BT_REG_ON) to power up the WLAN section. It is also OR-gated with the BT_REG_ON input to control the internal CYW4356 regulators. When this pin is high, the regulators are enabled and the WLAN section is out of reset. When this pin is low, the WLAN section is in reset. If BT_REG_ON and WL_REG_ON are both low, the regulators are disabled. This pin has an internal 200 kΩ pull-down resistor that is enabled by default. It can be disabled through programming.
BT_REG_ON	This signal is used by the PMU (with WL_REG_ON) to decide whether or not to power down the internal CYW4356 regulators. If BT_REG_ON and WL_REG_ON are low, the regulators will be disabled. This pin has an internal 200 kΩ pull-down resistor that is enabled by default. It can be disabled through programming.

## 2.7 Wireless Charging

The CYW4356 combo IC is designed for paired operation with the BCM59350 wireless power transfer front-end chip. Working together, the two chips form a power receiver unit (PRU) that is compliant with the Alliance for Wireless Power specification (A4WP). High-level functional block diagram for wireless charging is provided in Figure 4. The power transmit unit (PTU) resides in the charging pad while the power receive unit is integrated into the mobile device. The charging process begins as the mobile device is placed onto the charging pad. The power is transferred from PTU to PRU through the TX and RX coils by means of magnetic induction. The Bluetooth control link handles communications, i.e., handshaking, between them. PTU is a BLE client, which gets performance data from the BLE server (PRU) in order to adapt its power to the mobile's need.

**Figure 4. High-Level Functional Block Diagram for Wireless Charging**



Further details on the PRU are depicted in Figure 5. It shows both ICs along with a power switch, charger, power management IC, and the application processor (system).

Figure 5. Power Receiver Unit

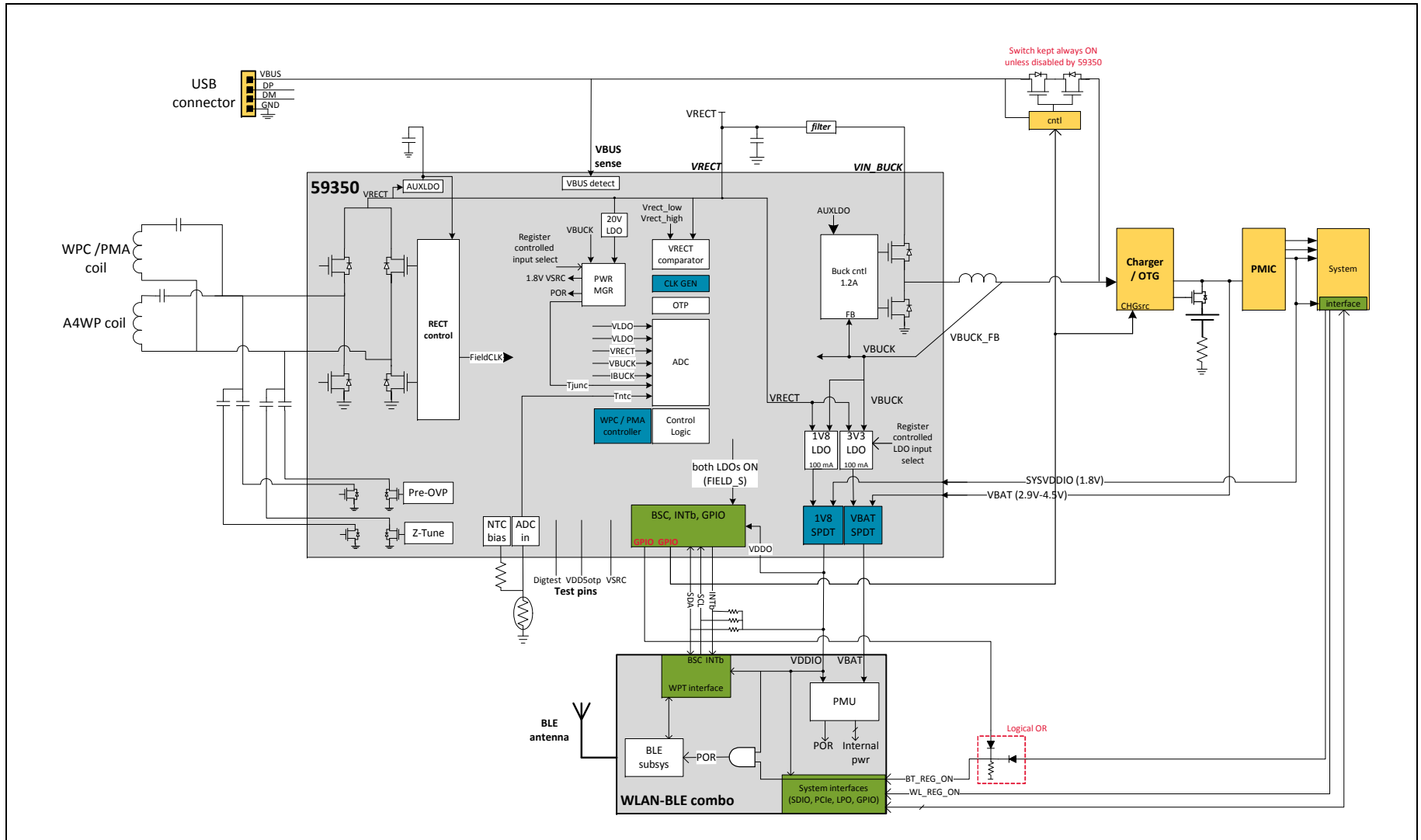
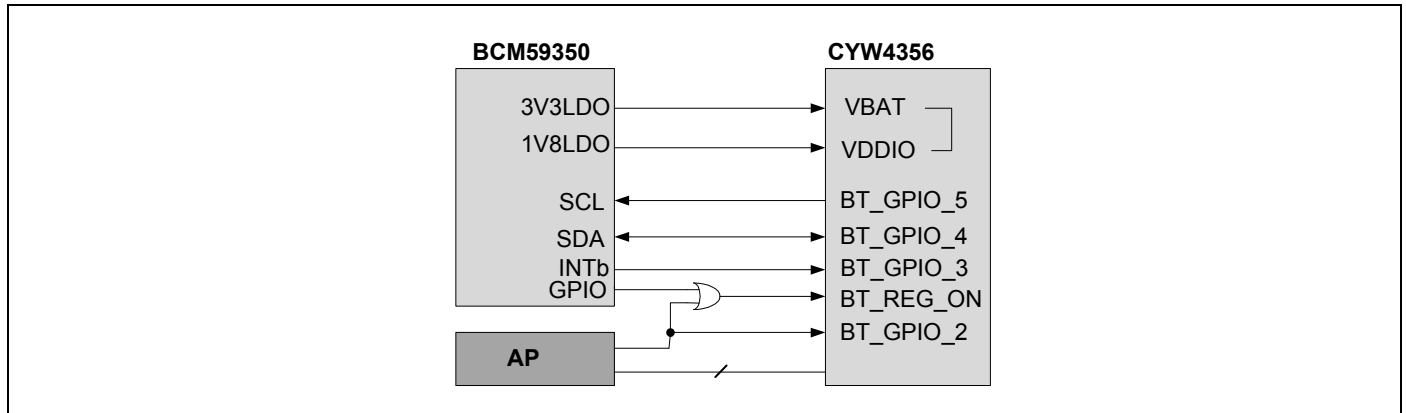


Figure 6 shows pin-to-pin connections between the CYW4356 and BCM59350, which consist of the following:

- Two Broadcom Serial Control (BSC)<sup>1</sup> data and clock lines.
- Two DC power supply lines.
- One interrupt (INTb) to the WLAN chip.
- One GPIO line, which is passed through an OR gate along with another signal from the application processor AP. This is for BT\_REG\_ON function, as illustrated in Figure 6.

**Figure 6. BCM59350 and CYW4356 Interface**



1. The Broadcom Serial Control bus is a proprietary bus compliant with the Philips I<sup>2</sup>C bus/interface.

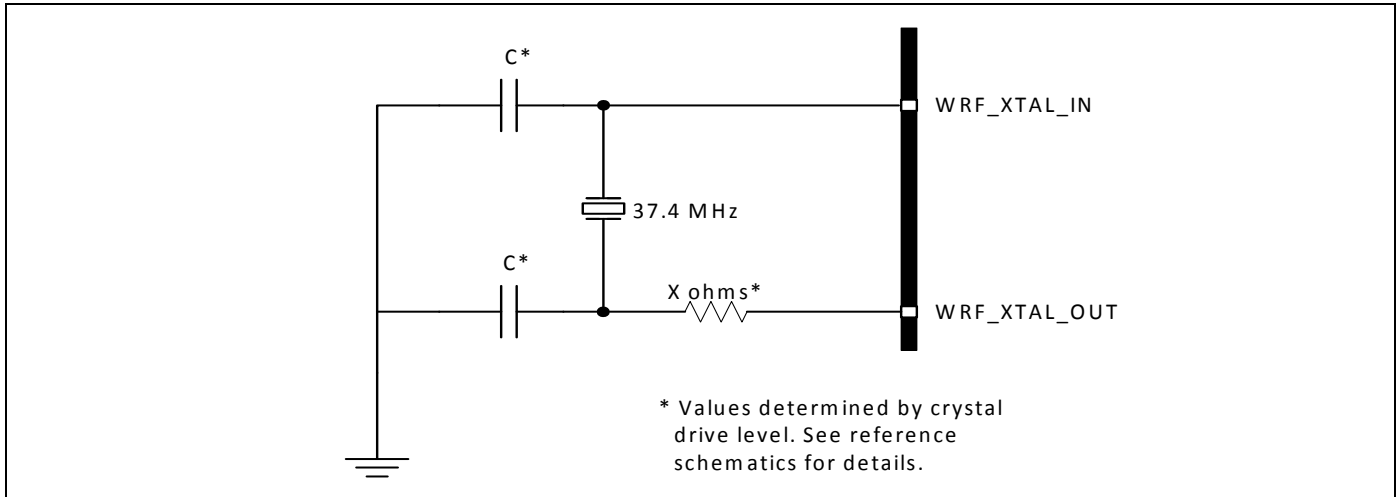
### 3. Frequency References

An external crystal is used for generating all radio frequencies and normal operation clocking. As an alternative, an external frequency reference may be used. In addition, a low-power oscillator (LPO) is provided for lower power mode timing.

#### 3.1 Crystal Interface and Clock Generation

The CYW4356 can use an external crystal to provide a frequency reference. The recommended configuration for the crystal oscillator including all external components is shown in Figure 7. Consult the reference schematics for the latest configuration.

**Figure 7. Recommended Oscillator Configuration**



A fractional-N synthesizer in the CYW4356 generates the radio frequencies, clocks, and data/packet timing, enabling it to operate using a wide selection of frequency references.

For SDIO and PCIe WLAN host applications, the recommended default frequency reference is a 37.4 MHz crystal. For PCIe applications, see Table 4 for details on alternatives for the external frequency reference. The signal characteristics for the crystal oscillator interface are also listed in Table 4.

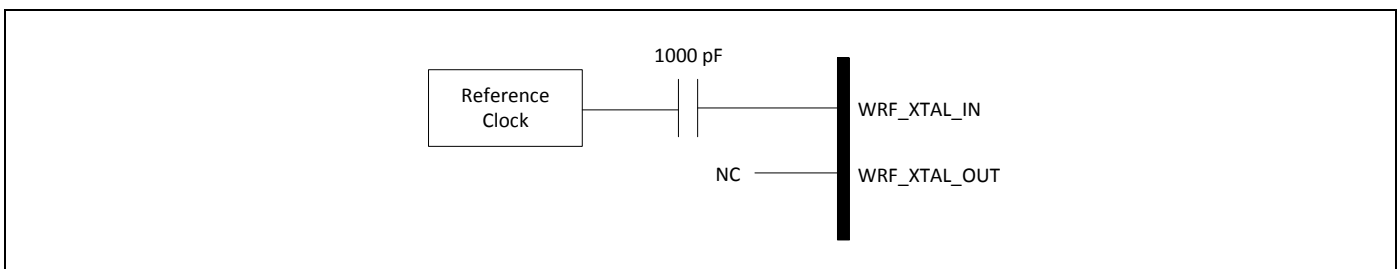
**Note:** Although the fractional-N synthesizer can support alternative reference frequencies, frequencies other than the default require support to be added in the driver, plus additional extensive system testing. Contact Cypress for further details.

#### 3.2 External Frequency Reference

For operation in SDIO mode only, an alternative to a crystal (an external precision frequency reference) can be used. The recommended default frequency is 52 MHz ±10 ppm, and it must meet the phase noise requirements listed in Table 4.

If used, the external clock should be connected to the WRF\_XTAL\_IN pin through an external 1000 pF coupling capacitor, as shown in Figure 8. The internal clock buffer connected to this pin will be turned OFF when the CYW4356 goes into sleep mode. When the clock buffer turns ON and OFF there will be a small impedance variation. Power must be supplied to the WRF\_XTAL\_VDD1P5 pin.

**Figure 8. Recommended Circuit to Use with an External Reference Clock**





**Table 4. Crystal Oscillator and External Clock—Requirements and Performance**

Parameter	Conditions/Notes	Crystal <sup>a</sup>			External Frequency Reference <sup>b, c</sup>			Units
		Min.	Typ.	Max.	Min.	Typ.	Max.	
Frequency	2.4G and 5G bands: IEEE 802.11ac operation, SDIO3.0, and PCIe WLAN interfaces	35	37.4	–	–	52	–	MHz
	2.4G and 5G bands, IEEE 802.11ac operation, PCIe interface alternative frequency	–	40	–	–	–	–	MHz
	5G band: IEEE 802.11n operation only	19	–	52	35	–	52	MHz
	2.4G band: IEEE 802.11n operation, and both bands legacy 802.11a/b/g operation only	Ranges between 19 MHz and 52 MHz <sup>d, e</sup>						
Frequency tolerance over the lifetime of the equipment, including temperature <sup>f</sup>	Without trimming	–20	–	20	–20	–	20	ppm
Crystal load capacitance	–	–	12	–	–	–	–	pF
ESR	–	–	–	60	–	–	–	Ω
Drive level	External crystal must be able to tolerate this drive level.	200	–	–	–	–	–	μW
Input impedance (WRF_X-TAL_IN)	Resistive	–	–	–	30	100	–	kΩ
	Capacitive	–	–	7.5	–	–	7.5	pF
WRF_XTAL_IN Input low level	DC-coupled digital signal	–	–	–	0	–	0.2	V
WRF_XTAL_IN Input high level	DC-coupled digital signal	–	–	–	1.0	–	1.26	V
WRF_XTAL_IN input voltage (see Figure 8)	AC-coupled analog signal	–	–	–	400	–	1200	mV <sub>p-p</sub>
Duty cycle	37.4 MHz clock	–	–	–	40	50	60	%
Phase Noise <sup>g</sup> (IEEE 802.11b/g)	37.4 MHz clock at 10 kHz offset	–	–	–	–	–	–129	dBc/Hz
	37.4 MHz clock at 100 kHz offset	–	–	–	–	–	–136	dBc/Hz
Phase Noise <sup>g</sup> (IEEE 802.11a)	37.4 MHz clock at 10 kHz offset	–	–	–	–	–	–137	dBc/Hz
	37.4 MHz clock at 100 kHz offset	–	–	–	–	–	–144	dBc/Hz
Phase Noise <sup>g</sup> (IEEE 802.11n, 2.4 GHz)	37.4 MHz clock at 10 kHz offset	–	–	–	–	–	–134	dBc/Hz
	37.4 MHz clock at 100 kHz offset	–	–	–	–	–	–141	dBc/Hz
Phase Noise <sup>g,h</sup> (IEEE 802.11n, 5 GHz)	37.4 MHz clock at 10 kHz offset	–	–	–	–	–	–142	dBc/Hz
	37.4 MHz clock at 100 kHz offset	–	–	–	–	–	–149	dBc/Hz
Phase Noise <sup>g</sup> (IEEE 802.11ac, 5 GHz)	37.4 MHz clock at 10 kHz offset	–	–	–	–	–	–150	dBc/Hz
	37.4 MHz clock at 100 kHz offset	–	–	–	–	–	–157	dBc/Hz

- a. (Crystal) Use WRF\_XTAL\_IN and WRF\_XTAL\_OUT.
- b. See [External Frequency Reference](#) for alternate connection methods.
- c. For a clock reference other than 37.4 MHz,  $20 \times \log_{10}(f/37.4)$  dB should be added to the limits, where f = the reference clock frequency in MHz.
- d. BT\_TM6 should be tied low for a 52 MHz clock reference. For other frequencies, BT\_TM6 should be tied high. Note that 52 MHz is not an auto-detected frequency using the LPO clock.
- e. The frequency step size is approximately 80 Hz resolution.
- f. It is the responsibility of the equipment designer to select oscillator components that comply with these specifications.
- g. Assumes that external clock has a flat phase noise response above 100 kHz.
- h. If the reference clock frequency is <35 MHz the phase noise requirements must be tightened by an additional 2 dB.

### 3.3 External 32.768 kHz Low-Power Oscillator

The CYW4356 uses a secondary low-frequency clock for Low-Power mode timing. Either the internal low-precision LPO or an external 32.768 kHz precision oscillator is required. The internal LPO frequency range is approximately 33 kHz ( $\pm 30\%$ ) over process, voltage, and temperature, which is adequate for some applications. However, one trade-off caused by this wide LPO tolerance is a small current consumption increase during power save mode that is incurred by the need to wake up earlier to avoid missing beacons.

Whenever possible, the preferred approach is to use a precision external 32.768 kHz clock which meets the requirements listed in [Table 5](#).

**Table 5. External 32.768 kHz Sleep Clock Specifications**

Parameter	LPO Clock	Unit
Nominal input frequency	32.768	kHz
Frequency accuracy	$\pm 200$	ppm
Duty cycle	30–70	%
Input signal amplitude	200–3300 <sup>a, b</sup>	mV, p-p
Signal type	Square-wave or sine-wave	–
Input impedance <sup>c</sup>	> 100k	$\Omega$
	< 5	pF
Clock jitter (during initial start-up)	< 10,000	ppm

a. The LPO\_IN input has an internal DC blocking capacitor, no external DC blocking is required.

b. The input DC offset must be  $\geq 0V$  to avoid conduction by the ESD protection diode.

c. When power is applied or switched off.

## 4. Bluetooth + FM Subsystem Overview

The Cypress CYW4356 is a Bluetooth 4.1 + EDR-compliant, baseband processor/2.4 GHz transceiver with an integrated FM/RDS/RBDS receiver. It features the highest level of integration and eliminates all critical external components, thus minimizing the footprint, power consumption, and system cost of a Bluetooth plus FM radio solution.

The CYW4356 is the optimal solution for any Bluetooth voice and/or data application that also requires an FM radio receiver. The Bluetooth subsystem presents a standard Host Controller Interface (HCI) via a high-speed UART and PCM for audio. The FM subsystem supports the HCI control interface, analog output, as well as I<sup>2</sup>S and PCM interfaces. The CYW4356 incorporates all Bluetooth 4.1 features including secure simple pairing, sniff subrating, and encryption pause and resume.

The CYW4356 Bluetooth radio transceiver provides enhanced radio performance to meet the most stringent mobile phone temperature applications and the tightest integration into mobile handsets and portable devices. It is fully compatible with any of the standard TCXO frequencies and provides full radio compatibility to operate simultaneously with GPS, WLAN, and cellular radios.

The Bluetooth transmitter also features a Class 1 power amplifier with Class 2 capability.

### 4.1 Features

**Major Bluetooth features of the CYW4356 include:**

- Supports key features of upcoming Bluetooth standards
- Fully supports Bluetooth Core Specification version 4.1 + (Enhanced Data Rate) EDR features:
  - Adaptive Frequency Hopping (AFH)
  - Quality of Service (QoS)
  - Extended Synchronous Connections (eSCO)—Voice Connections
  - Fast Connect (interlaced page and inquiry scans)
  - Secure Simple Pairing (SSP)
  - Sniff Subrating (SSR)
  - Encryption Pause Resume (EPR)
  - Extended Inquiry Response (EIR)
  - Link Supervision Timeout (LST)
- UART baud rates up to 4 Mbps
- Supports all Bluetooth 4.1 packet types
- Supports maximum Bluetooth data rates over HCI UART
- BT supports full-speed USB 2.0-compliant interface
- Multipoint operation with up to seven active slaves
  - Maximum of seven simultaneous active ACL links
  - Maximum of three simultaneous active SCO and eSCO connections with scatternet support
- Trigger Broadcom fast connect (TBFC)
- Narrowband and wideband packet loss concealment
- Scatternet operation with up to four active piconets with background scan and support for scatter mode
- High-speed HCI UART transport support with low-power out-of-band BT\_DEV\_WAKE and BT\_HOST\_WAKE signaling (see “[Host Controller Power Management](#)”)
- Channel quality driven data rate and packet type selection
- Standard Bluetooth test modes
- Extended radio and production test mode features
- Full support for power savings modes
  - Bluetooth clock request
  - Bluetooth standard sniff
  - Deep-sleep modes and software regulator shutdown
- TCXO input and auto-detection of all standard handset clock frequencies. Also supports a low-power crystal, which can be used during power-save mode for better timing accuracy.

**Major FM Radio features include:**

- 65 MHz to 108 MHz FM bands supported (US, Europe, and Japan)
- FM subsystem control using the Bluetooth HCI interface
- FM subsystem operates from reference clock inputs.
- Improved audio interface capabilities with full-featured bidirectional PCM and I<sup>2</sup>S
- I<sup>2</sup>S can be master or slave.

**FM receiver-specific features include:**

- Excellent FM radio performance with 1  $\mu$ V sensitivity for 26 dB (S+N)/N
- Signal-dependent stereo/mono blending
- Signal dependent soft mute
- Auto search and tuning modes
- Audio silence detection
- RSSI, IF frequency, status indicators
- RDS and RBDS demodulator and decoder with filter and buffering functions
- Automatic frequency jump

## 4.2 Bluetooth Radio

The CYW4356 has an integrated radio transceiver that has been optimized for use in 2.4 GHz Bluetooth wireless systems. It has been designed to provide low-power, low-cost, robust communications for applications operating in the globally available 2.4 GHz unlicensed ISM band. It is fully compliant with the Bluetooth Radio Specification and EDR specification and meets or exceeds the requirements to provide the highest communication link quality of service.

### 4.2.1 Transmit

The CYW4356 features a fully integrated zero-IF transmitter. The baseband transmit data is GFSK-modulated in the modem block and upconverted to the 2.4 GHz ISM band in the transmitter path. The transmitter path consists of signal filtering, I/Q upconversion, output power amplifier, and RF filtering. The transmitter path also incorporates  $\pi/4$ -DQPSK for 2 Mbps and 8-DPSK for 3 Mbps to support EDR. The transmitter section is compatible to the Bluetooth Low Energy specification. The transmitter PA bias can also be adjusted to provide Bluetooth class 1 or class 2 operation.

### 4.2.2 Digital Modulator

The digital modulator performs the data modulation and filtering required for the GFSK,  $\pi/4$ -DQPSK, and 8-DPSK signal. The fully digital modulator minimizes any frequency drift or anomalies in the modulation characteristics of the transmitted signal and is much more stable than direct VCO modulation schemes.

### 4.2.3 Digital Demodulator and Bit Synchronizer

The digital demodulator and bit synchronizer take the low-IF received signal and perform an optimal frequency tracking and bit-synchronization algorithm.

### 4.2.4 Power Amplifier

The fully integrated PA supports Class 1 or Class 2 output using a highly linearized, temperature-compensated design. This provides greater flexibility in front-end matching and filtering. Due to the linear nature of the PA combined with some integrated filtering, external filtering is required to meet the Bluetooth and regulatory harmonic and spurious requirements. For integrated mobile handset applications in which Bluetooth is integrated next to the cellular radio, external filtering can be applied to achieve near thermal noise levels for spurious and radiated noise emissions. The transmitter features a sophisticated on-chip transmit signal strength indicator (TSSI) block to keep the absolute output power variation within a tight range across process, voltage, and temperature.

#### 4.2.5 Receiver

The receiver path uses a low-IF scheme to downconvert the received signal for demodulation in the digital demodulator and bit synchronizer. The receiver path provides a high degree of linearity, an extended dynamic range, and high-order on-chip channel filtering to ensure reliable operation in the noisy 2.4 GHz ISM band. The front-end topology with built-in out-of-band attenuation enables the CYW4356 to be used in most applications with minimal off-chip filtering. For integrated handset operation, in which the Bluetooth function is integrated close to the cellular transmitter, external filtering is required to eliminate the desensitization of the receiver by the cellular transmit signal.

#### 4.2.6 Digital Demodulator and Bit Synchronizer

The digital demodulator and bit synchronizer take the low-IF received signal and perform an optimal frequency tracking and bit synchronization algorithm.

#### 4.2.7 Receiver Signal Strength Indicator

The radio portion of the CYW4356 provides a Receiver Signal Strength Indicator (RSSI) signal to the baseband, so that the controller can take part in a Bluetooth power-controlled link by providing a metric of its own receiver signal strength to determine whether the transmitter should increase or decrease its output power.

#### 4.2.8 Local Oscillator Generation

Local Oscillator (LO) generation provides fast frequency hopping (1600 hops/second) across the 79 maximum available channels. The LO generation subblock employs an architecture for high immunity to LO pulling during PA operation. The CYW4356 uses an internal RF and IF loop filter.

#### 4.2.9 Calibration

The CYW4356 radio transceiver features an automated calibration scheme that is fully self contained in the radio. No user interaction is required during normal operation or during manufacturing to provide the optimal performance. Calibration optimizes the performance of all the major blocks within the radio to within 2% of optimal conditions, including gain and phase characteristics of filters, matching between key components, and key gain blocks. This takes into account process variation and temperature variation. Calibration occurs transparently during normal operation during the settling time of the hops and calibrates for temperature variations as the device cools and heats during normal operation in its environment.

## 5. Bluetooth Baseband Core

The Bluetooth Baseband Core (BBC) implements all of the time critical functions required for high-performance Bluetooth operation. The BBC manages the buffering, segmentation, and routing of data for all connections. It also buffers data that passes through it, handles data flow control, schedules SCO/ACL TX/RX transactions, monitors Bluetooth slot usage, optimally segments and packages data into baseband packets, manages connection status indicators, and composes and decodes HCI packets. In addition to these functions, it independently handles HCI event types, and HCI command types.

The following transmit and receive functions are also implemented in the BBC hardware to increase reliability and security of the TX/RX data before sending over the air:

- Symbol timing recovery, data deframing, forward error correction (FEC), header error control (HEC), cyclic redundancy check (CRC), data decryption, and data dewatering in the receiver.
- Data framing, FEC generation, HEC generation, CRC generation, key generation, data encryption, and data whitening in the transmitter.

### 5.1 Bluetooth 4.1 Features

The BBC supports all Bluetooth 4.1 features, with the following benefits:

- Dual-mode bluetooth Low Energy (BT and BLE operation)
- Extended Inquiry Response (EIR): Shortens the time to retrieve the device name, specific profile, and operating mode.
- Encryption Pause Resume (EPR): Enables the use of Bluetooth technology in a much more secure environment.
- Sniff Subrating (SSR): Optimizes power consumption for low duty cycle asymmetric data flow, which subsequently extends battery life.
- Secure Simple Pairing (SSP): Reduces the number of steps for connecting two devices, with minimal or no user interaction required.
- Link Supervision Time Out (LSTO): Additional commands added to HCI and Link Management Protocol (LMP) for improved link time-out supervision.
- QoS enhancements: Changes to data traffic control, which results in better link performance. Audio, human interface device (HID), bulk traffic, SCO, and enhanced SCO (eSCO) are improved with the erroneous data (ED) and packet boundary flag (PBF) enhancements.

### 5.2 Bluetooth Low Energy

The CYW4356 supports the Bluetooth Low Energy operating mode.

### 5.3 Link Control Layer

The link control layer is part of the Bluetooth link control functions that are implemented in dedicated logic in the link control unit (LCU). This layer consists of the command controller that takes commands from the software, and other controllers that are activated or configured by the command controller, to perform the link control tasks. Each task performs a different state in the Bluetooth Link Controller.

- Major states:
  - Standby
  - Connection
- Substates:
  - Page
  - Page Scan
  - Inquiry
  - Inquiry Scan
  - Sniff

## 5.4 Test Mode Support

The CYW4356 fully supports Bluetooth Test mode as described in Part I:1 of the *Specification of the Bluetooth System Version 3.0*. This includes the transmitter tests, normal and delayed loopback tests, and reduced hopping sequence.

In addition to the standard Bluetooth Test Mode, the CYW4356 also supports enhanced testing features to simplify RF debugging and qualification and type-approval testing. These features include:

- Fixed frequency carrier wave (unmodulated) transmission
  - Simplifies some type-approval measurements (Japan)
  - Aids in transmitter performance analysis
- Fixed frequency constant receiver mode
  - Receiver output directed to I/O pin
  - Allows for direct BER measurements using standard RF test equipment
  - Facilitates spurious emissions testing for receive mode
- Fixed frequency constant transmission
  - Eight-bit fixed pattern or PRBS-9
  - Enables modulated signal measurements with standard RF test equipment

## 5.5 Bluetooth Power Management Unit

The Bluetooth Power Management Unit (PMU) provides power management features that can be invoked by either software through power management registers or packet handling in the baseband core. The power management functions provided by the CYW4356 are:

- [RF Power Management](#)
- [Host Controller Power Management](#)
- [BBC Power Management](#)
- [FM Power Management](#)

### 5.5.1 RF Power Management

The BBC generates power-down control signals for the transmit path, receive path, PLL, and power amplifier to the 2.4 GHz transceiver. The transceiver then processes the power-down functions accordingly.

### 5.5.2 Host Controller Power Management

When running in UART mode, the CYW4356 may be configured so that dedicated signals are used for power management hand-shaking between the CYW4356 and the host. The basic power saving functions supported by those hand-shaking signals include the standard Bluetooth defined power savings modes and standby modes of operation. [Table 6](#) describes the power-control hand-shake signals used with the UART interface.

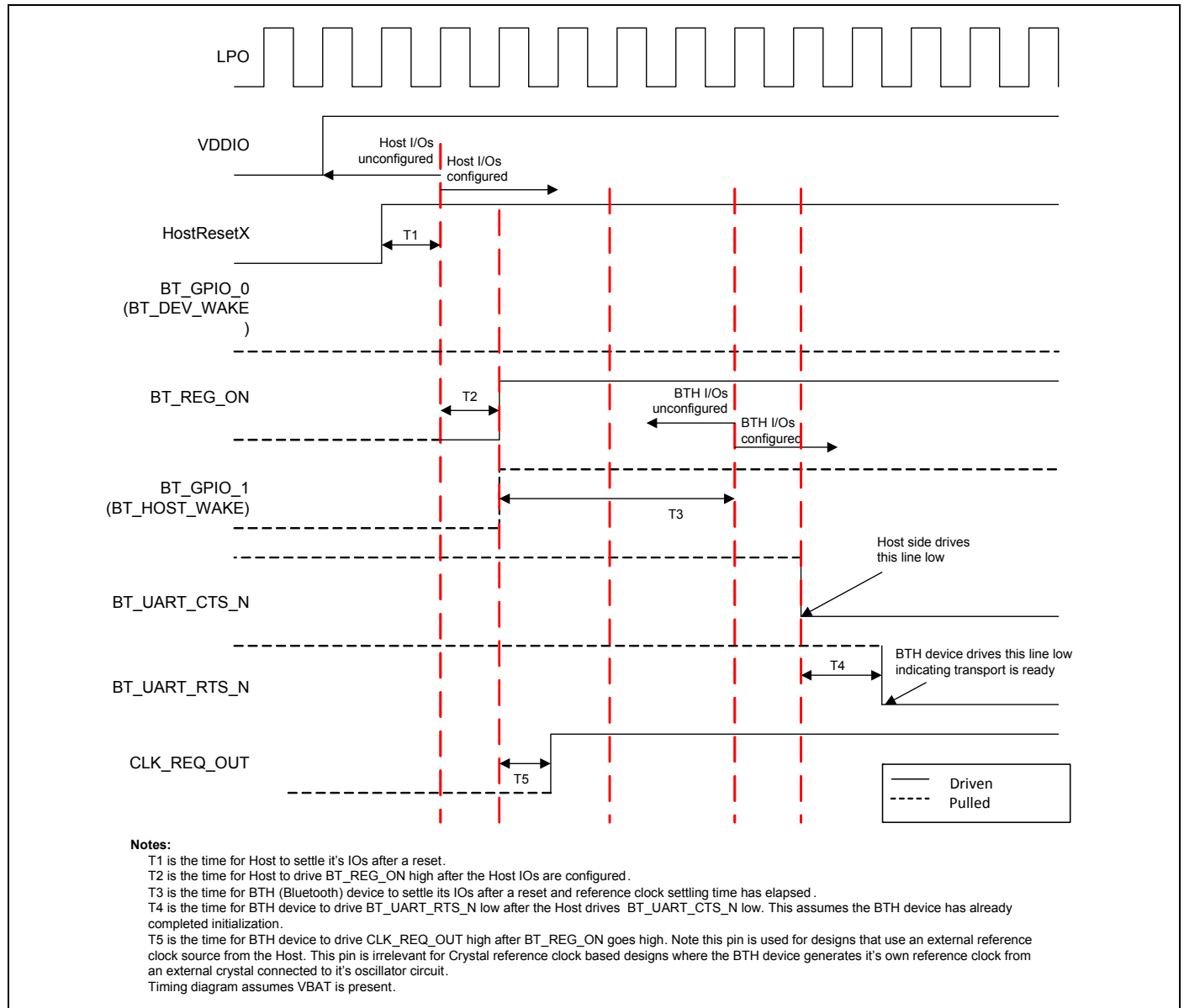
**Table 6. Power Control Pin Description**

Signal	Mapped to Pin	Type	Description
BT_DEV_WAKE	BT_GPIO_0	I	Bluetooth device wake-up: Signal from the host to the CYW4356 indicating that the host requires attention. ■ Asserted: The Bluetooth device must wake-up or remain awake. ■ Deasserted: The Bluetooth device may sleep when sleep criteria are met. The polarity of this signal is software configurable and can be asserted high or low.
BT_HOST_WAKE	BT_GPIO_1	O	Host wake up. Signal from the CYW4356 to the host indicating that the CYW4356 requires attention. ■ Asserted: host device must wake-up or remain awake. ■ Deasserted: host device may sleep when sleep criteria are met. The polarity of this signal is software configurable and can be asserted high or low.
CLK_REQ	BT_CLK_REQ_OUT WL_CLK_REQ_OUT	O	The CYW4356 asserts CLK_REQ when Bluetooth or WLAN wants the host to turn on the reference clock. The CLK_REQ polarity is active-high. Add an external 100 kΩ pull-down resistor to ensure the signal is deasserted when the CYW4356 powers up or resets when VDDIO is present.

**Note:** Pad function Control Register is set to 0 for these pins. See “[DC Characteristics](#)” for more details.

The timing for the startup sequence is defined in Figure 9.

**Figure 9. Startup Signaling Sequence**





### 5.5.3 BBC Power Management

The following are low-power operations for the BBC:

- Physical layer packet-handling turns the RF on and off dynamically within transmit/receive packets.
- Bluetooth-specified low-power connection modes: sniff, hold, and park. While in these modes, the CYW4356 runs on the low-power oscillator and wakes up after a predefined time period.
- A low-power shutdown feature allows the device to be turned off while the host and any other devices in the system remain operational. When the CYW4356 is not needed in the system, the RF and core supplies are shut down while the I/O remains powered. This allows the CYW4356 to effectively be off while keeping the I/O pins powered so they do not draw extra current from any other devices connected to the I/O.

During the low-power shut-down state, provided VDDIO remains applied to the CYW4356, all outputs are tristated, and most input signals are disabled. Input voltages must remain within the limits defined for normal operation. This is done to prevent current paths or create loading on any digital signals in the system and enables the CYW4356 to be fully integrated in an embedded device to take full advantage of the lowest power-saving modes.

Two CYW4356 input signals are designed to be high-impedance inputs that do not load the driving signal even if the chip does not have VDDIO power supplied to it: the frequency reference input (WRF\_TCXO\_IN) and the 32.768 kHz input (LPO). When the CYW4356 is powered on from this state, it is the same as a normal power-up, and the device does not contain any information about its state from the time before it was powered down.

### 5.5.4 FM Power Management

The CYW4356 FM subsystem can operate independently of, or in tandem with, the Bluetooth RF and BBC subsystems. The FM subsystem power management scheme operates in conjunction with the Bluetooth RF and BBC subsystems. The FM block does not have a low power state, it is either on or off.

### 5.5.5 Wideband Speech

The CYW4356 provides support for wideband speech (WBS) using on-chip SmartAudio technology. The CYW4356 can perform subband-codec (SBC), as well as mSBC, encoding and decoding of linear 16 bits at 16 kHz (256 Kbps rate) transferred over the PCM bus.

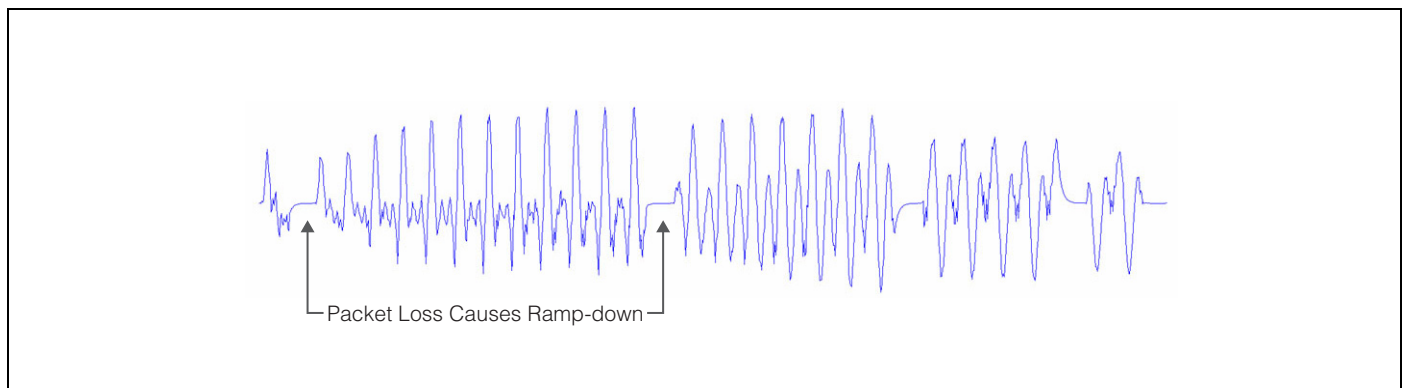
### 5.5.6 Packet Loss Concealment

Packet Loss Concealment (PLC) improves apparent audio quality for systems with marginal link performance. Bluetooth messages are sent in packets. When a packet is lost, it creates a gap in the received audio bit-stream. Packet loss can be mitigated in several ways:

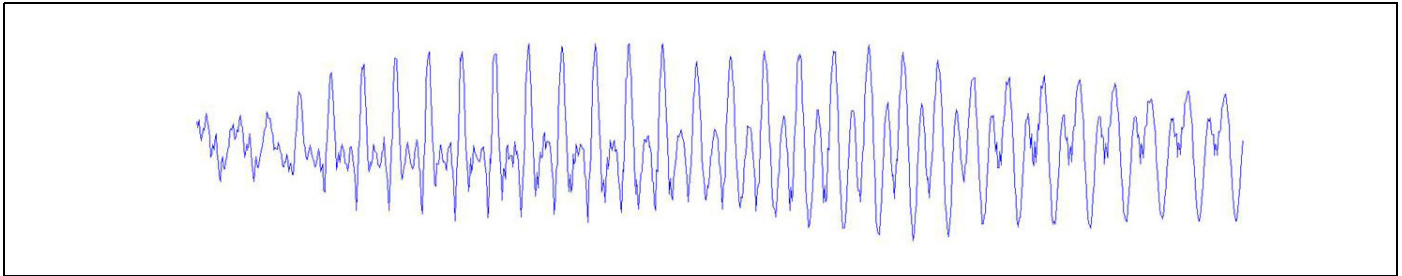
- Fill in zeros.
- Ramp down the output audio signal toward zero (this is the method used in current Bluetooth headsets).
- Repeat the last frame (or packet) of the received bit-stream and decode it as usual (frame repeat).

These techniques cause distortion and popping in the audio stream. The CYW4356 uses a proprietary waveform extension algorithm to provide dramatic improvement in the audio quality. [Figure 10](#) and [Figure 11](#) show audio waveforms with and without Packet Loss Concealment. Cypress PLC/BEC algorithms also support wideband speech.

**Figure 10. CVSD Decoder Output Waveform Without PLC**



**Figure 11. CVSD Decoder Output Waveform After Applying PLC**



#### 5.5.7 Audio Rate-Matching Algorithms

The CYW4356 has an enhanced rate-matching algorithm that uses interpolation algorithms to reduce audio stream jitter that may be present when the rate of audio data coming from the host is not the same as the Bluetooth or FM audio data rates.

#### 5.5.8 Codec Encoding

The CYW4356 can support SBC and mSBC encoding and decoding for wideband speech.

#### 5.5.9 Multiple Simultaneous A2DP Audio Stream

The CYW4356 has the ability to take a single audio stream and output it to multiple Bluetooth devices simultaneously. This allows a user to share his or her music (or any audio stream) with a friend.

#### 5.5.10 FM Over Bluetooth

FM Over Bluetooth enables the CYW4356 to stream data from FM over Bluetooth without requiring the host to be awake. This can significantly extend battery life for usage cases where someone is listening to FM radio on a Bluetooth headset.

#### 5.5.11 Burst Buffer Operation

The CYW4356 has a data buffer that can buffer data being sent over the HCI and audio transports, then send the data at an increased rate. This mode of operation allows the host to sleep for the maximum amount of time, dramatically reducing system current consumption.

### 5.6 Adaptive Frequency Hopping

The CYW4356 gathers link quality statistics on a channel by channel basis to facilitate channel assessment and channel map selection. The link quality is determined using both RF and baseband signal processing to provide a more accurate frequency-hop map.

### 5.7 Advanced Bluetooth/WLAN Coexistence

The CYW4356 includes advanced coexistence technologies that are only possible with a Bluetooth/WLAN integrated die solution. These coexistence technologies are targeted at small form-factor platforms, such as cell phones and media players, including applications such as VoWLAN + SCO and Video-over-WLAN + High Fidelity BT Stereo.

Support is provided for platforms that share a single antenna between Bluetooth and WLAN. Dual-antenna applications are also supported. The CYW4356 radio architecture allows for lossless simultaneous Bluetooth and WLAN reception for shared antenna applications. This is possible only via an integrated solution (shared LNA and joint AGC algorithm). It has superior performance versus implementations that need to arbitrate between Bluetooth and WLAN reception.

The CYW4356 integrated solution enables MAC-layer signaling (firmware) and a greater degree of sharing via an enhanced coexistence interface. Information is exchanged between the Bluetooth and WLAN cores without host processor involvement.

The CYW4356 also supports Transmit Power Control on the STA together with standard Bluetooth TPC to limit mutual interference and receiver desensitization. Preemption mechanisms are utilized to prevent AP transmissions from colliding with Bluetooth frames. Improved channel classification techniques have been implemented in Bluetooth for faster and more accurate detection and elimination of interferers (including non-WLAN 2.4 GHz interference).

The Bluetooth AFH classification is also enhanced by the WLAN core's channel information.

### 5.8 Fast Connection (Interlaced Page and Inquiry Scans)

The CYW4356 supports page scan and inquiry scan modes that significantly reduce the average inquiry response and connection times. These scanning modes are compatible with the Bluetooth version 2.1 page and inquiry procedures.

## **6. Microprocessor and Memory Unit for Bluetooth**

The Bluetooth microprocessor core is based on the ARM Cortex-M3 32-bit RISC processor with embedded ICE-RT debug and JTAG interface units. It runs software from the link control (LC) layer, up to the host controller interface (HCI).

The ARM core is paired with a memory unit that contains 668 KB of ROM memory for program storage and boot ROM, 200 KB of RAM for data scratchpad and patch RAM code. The internal ROM allows for flexibility during power-on reset to enable the same device to be used in various configurations. At power-up, the lower-layer protocol stack is executed from the internal ROM memory.

External patches may be applied to the ROM-based firmware to provide flexibility for bug fixes or features additions. These patches may be downloaded from the host to the CYW4356 through the UART transports. The mechanism for downloading via UART is identical to the proven interface of the CYW4330 device.

### **6.1 RAM, ROM, and Patch Memory**

The CYW4356 Bluetooth core has 200 KB of internal RAM which is mapped between general purpose scratch pad memory and patch memory and 668 KB of ROM used for the lower-layer protocol stack, test mode software, and boot ROM. The patch memory capability enables the addition of code changes for purposes of feature additions and bug fixes to the ROM memory.

### **6.2 Reset**

The CYW4356 has an integrated power-on reset circuit that resets all circuits to a known power-on state. The BT power-on reset (POR) circuit is out of reset after BT\_REG\_ON goes High. If BT\_REG\_ON is low, then the POR circuit is held in reset.

## 7. Bluetooth Peripheral Transport Unit

### 7.1 SPI Interface

The CYW4356 supports a slave SPI HCI transport with an input clock range of up to 16 MHz. Higher clock rates can be possible. The physical interface between the SPI master and the CYW4356 consists of the four SPI signals (SPI\_CSB, SPI\_CLK, SPI\_SI, and SPI\_SO) and one interrupt signal (SPI\_INT). The SPI signals are muxed onto the UART signals, see Table 7. The CYW4356 can be configured to accept active-low or active-high polarity on the SPI\_CSB chip select signal. It can also be configured to drive an active-low or active-high SPI\_INT interrupt signal. Bit ordering on the SPI\_SI and SPI\_SO data lines can be configured as either little-endian or big-endian. Additionally, proprietary sleep mode and half-duplex handshaking is implemented between the SPI master and the CYW4356. The SPI\_INT is required to negotiate the start of a transaction. The SPI interface does not require flow control in the middle of a payload. The FIFO is large enough to handle the largest packet size. Only the SPI master can stop the flow of bytes on the data lines, since it controls SPI\_CSB and SPI\_CLK. Flow control should be implemented in the higher layer protocols.

**Table 7. SPI to UART Signal Mapping**

SPI Signals	UART Signals
SPI_CLK	UART_CTS_N
SPI_CSB	UART_RTS_N
SPI_MISO	UART_TXD
SPI_MOSI	UART_RXD
SPI_INT	BT_DEV_WAKE

### 7.2 SPI/UART Transport Detection

The BT\_HOST\_WAKE (BT\_GPIO1) pin is also used for BT transport detection. The transport detection occurs during the power-up sequence. It selects either UART or SPI transport operation based on the following pin state:

- If the BT\_HOST\_WAKE (BT\_GPIO1) pin is pulled low by an external pull-down during power-up, it selects the SPI transport interface.
- If the BT\_HOST\_WAKE (BT\_GPIO1) pin is not pulled low externally during power-up, then the default internal pull-up is detected as a high and it selects the UART transport interface.

When the A4WP feature is *not* used and USB is selected as the Bluetooth interface to the host, an external pull-up (outside the chip) 10 KΩ resistor to BT\_VDDIO is required. The pull-up is not necessary but is recommended when the Bluetooth/host interface is UART instead of USB.

### 7.3 PCM Interface

The CYW4356 supports two independent PCM interfaces that share the pins with the I<sup>2</sup>S interfaces. The PCM Interface on the CYW4356 can connect to linear PCM codec devices in master or slave mode. In master mode, the CYW4356 generates the PCM\_CLK and PCM\_SYNC signals, and in slave mode, these signals are provided by another master on the PCM interface and are inputs to the CYW4356.

The configuration of the PCM interface may be adjusted by the host through the use of vendor-specific HCI commands.

#### 7.3.1 Slot Mapping

The CYW4356 supports up to three simultaneous full-duplex SCO or eSCO channels through the PCM interface. These three channels are time-multiplexed onto the single PCM interface by using a time-slotting scheme where the 8 kHz or 16 kHz audio sample interval is divided into as many as 16 slots. The number of slots is dependent on the selected interface rate of 128 kHz, 512 kHz, or 1024 kHz. The corresponding number of slots for these interface rate is 1, 2, 4, 8, and 16, respectively. Transmit and receive PCM data from an SCO channel is always mapped to the same slot. The PCM data output driver tristates its output on unused slots to allow other devices to share the same PCM interface signals. The data output driver tristates its output after the falling edge of the PCM clock during the last bit of the slot.

#### 7.3.2 Frame Synchronization

The CYW4356 supports both short- and long-frame synchronization in both master and slave modes. In short-frame synchronization mode, the frame synchronization signal is an active-high pulse at the audio frame rate that is a single-bit period in width and is synchronized to the rising edge of the bit clock. The PCM slave looks for a high on the falling edge of the bit clock and expects the first bit of the first slot to start at the next rising edge of the clock. In long-frame synchronization mode, the frame synchronization signal is again an active-high pulse at the audio frame rate; however, the duration is three bit periods and the pulse starts coincident with the first bit of the first slot.

### 7.3.3 Data Formatting

The CYW4356 may be configured to generate and accept several different data formats. For conventional narrowband speech mode, the CYW4356 uses 13 of the 16 bits in each PCM frame. The location and order of these 13 bits can be configured to support various data formats on the PCM interface. The remaining three bits are ignored on the input and may be filled with 0s, 1s, a sign bit, or a programmed value on the output. The default format is 13-bit 2's complement data, left justified, and clocked MSB first.

### 7.3.4 Wideband Speech Support

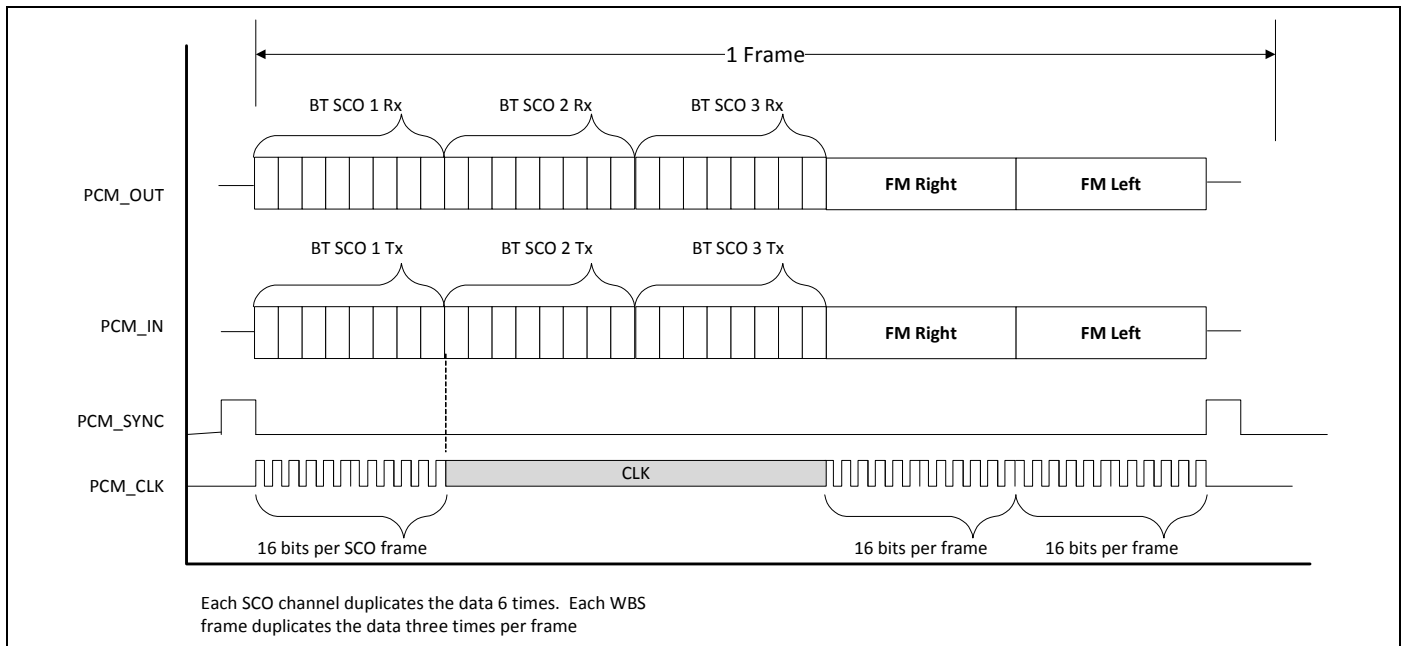
When the host encodes Wideband Speech (WBS) packets in transparent mode, the encoded packets are transferred over the PCM bus for an eSCO voice connection. In this mode, the PCM bus is typically configured in master mode for a 4 kHz sync rate with 16-bit samples, resulting in a 64 Kbps bit rate. The CYW4356 also supports slave transparent mode using a proprietary rate-matching scheme. In SBC-code mode, linear 16-bit data at 16 kHz (256 Kbps rate) is transferred over the PCM bus.

### 7.3.5 Multiplexed Bluetooth and FM Over PCM

In this mode of operation, the CYW4356 multiplexes both FM and Bluetooth audio PCM channels over the same interface, reducing the number of required I/Os. This mode of operation is initiated through an HCI command from the host. The format of the data stream consists of three channels: a Bluetooth channel followed by two FM channels (audio left and right). In this mode of operation, the bus data rate only supports 48 kHz operation per channel with 16 bits sent for each channel. This is done to allow the low data rate Bluetooth data to coexist in the same interface as the higher speed I<sup>2</sup>S data. To accomplish this, the Bluetooth data is repeated six times for 8 kHz data and three times for 16 kHz data. An initial sync pulse on the PCM\_SYNC line is used to indicate the beginning of the frame.

To support multiple Bluetooth audio streams within the Bluetooth channel, both 16 kHz and 8 kHz streams can be multiplexed. This mode of operation is only supported when the Bluetooth host is the master. Figure 12 shows the operation of the multiplexed transport with three simultaneous SCO connections. To accommodate additional SCO channels, the transport clock speed is increased. To change between modes of operation, the transport must be halted and restarted in the new configuration.

**Figure 12. Functional Multiplex Data Diagram**



### 7.3.6 Burst PCM Mode

In this mode of operation, the PCM bus runs at a significantly higher rate of operation to allow the host to duty cycle its operation and save current. In this mode of operation, the PCM bus can operate at a rate of up to 24 MHz. This mode of operation is initiated with an HCI command from the host.

7.3.7 PCM Interface Timing

Short Frame Sync, Master Mode

Figure 13. PCM Timing Diagram (Short Frame Sync, Master Mode)

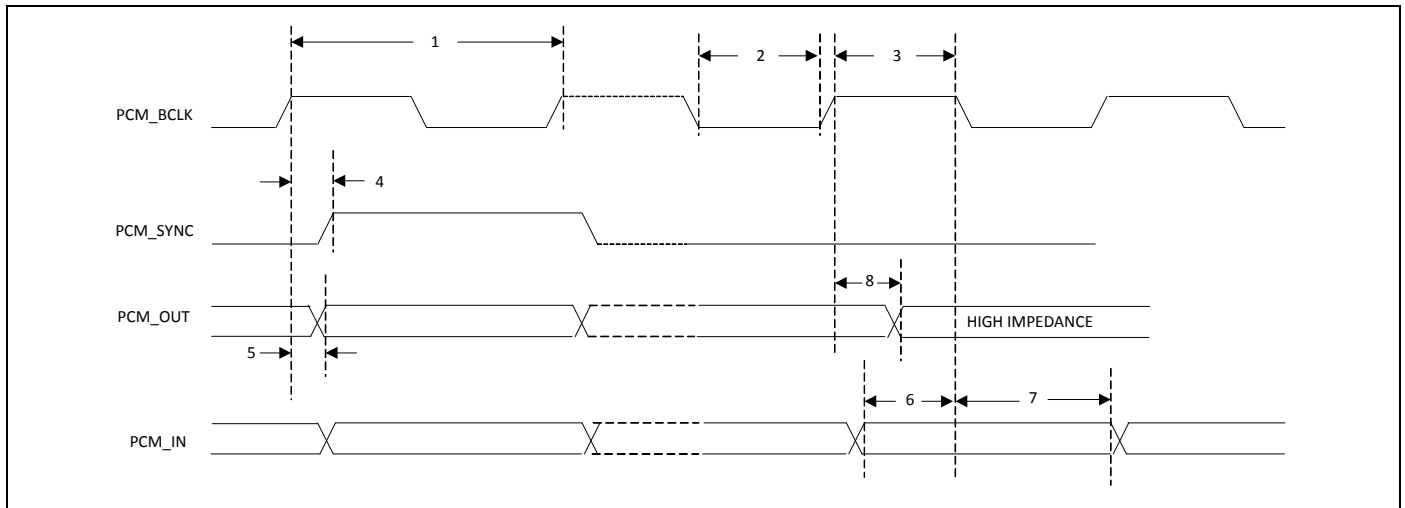


Table 8. PCM Interface Timing Specifications (Short Frame Sync, Master Mode)

Ref No.	Characteristics	Minimum	Typical	Maximum	Unit
1	PCM bit clock frequency	–	–	12	MHz
2	PCM bit clock LOW	41	–	–	ns
3	PCM bit clock HIGH	41	–	–	ns
4	PCM_SYNC delay	0	–	25	ns
5	PCM_OUT delay	0	–	25	ns
6	PCM_IN setup	8	–	–	ns
7	PCM_IN hold	8	–	–	ns
8	Delay from rising edge of PCM_BCLK during last bit period to PCM_OUT becoming high impedance	0	–	25	ns

Short Frame Sync, Slave Mode

Figure 14. PCM Timing Diagram (Short Frame Sync, Slave Mode)

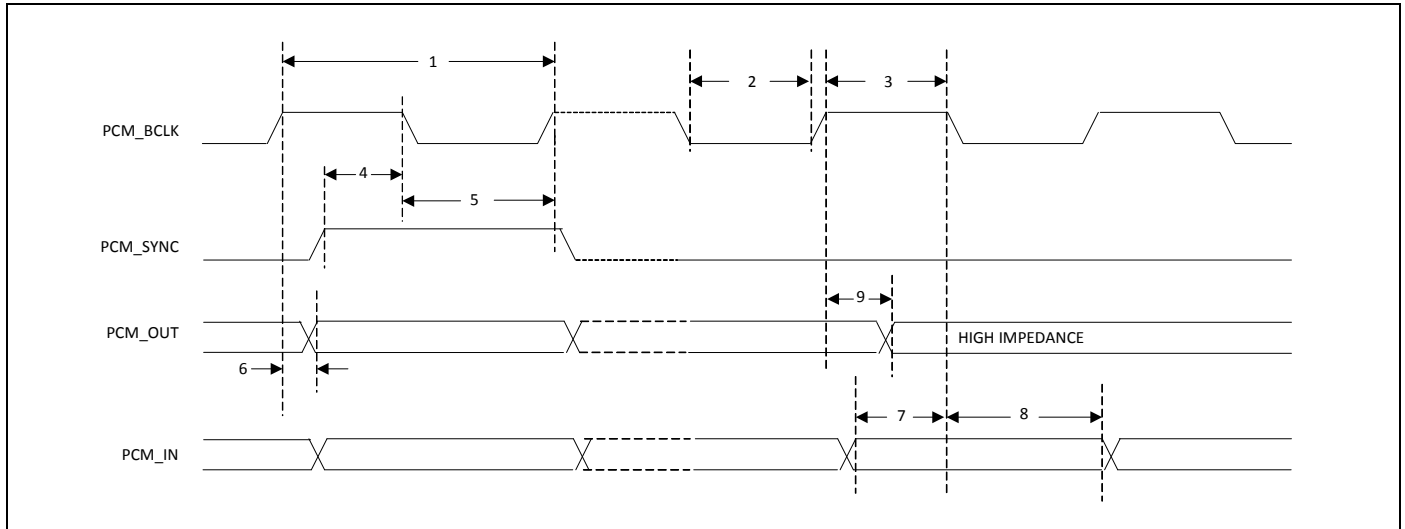


Table 9. PCM Interface Timing Specifications (Short Frame Sync, Slave Mode)

Ref No.	Characteristics	Minimum	Typical	Maximum	Unit
1	PCM bit clock frequency	–	–	12	MHz
2	PCM bit clock LOW	41	–	–	ns
3	PCM bit clock HIGH	41	–	–	ns
4	PCM_SYNC setup	8	–	–	ns
5	PCM_SYNC hold	8	–	–	ns
6	PCM_OUT delay	0	–	25	ns
7	PCM_IN setup	8	–	–	ns
8	PCM_IN hold	8	–	–	ns
9	Delay from rising edge of PCM_BCLK during last bit period to PCM_OUT becoming high impedance	0	–	25	ns

Long Frame Sync, Master Mode

Figure 15. PCM Timing Diagram (Long Frame Sync, Master Mode)

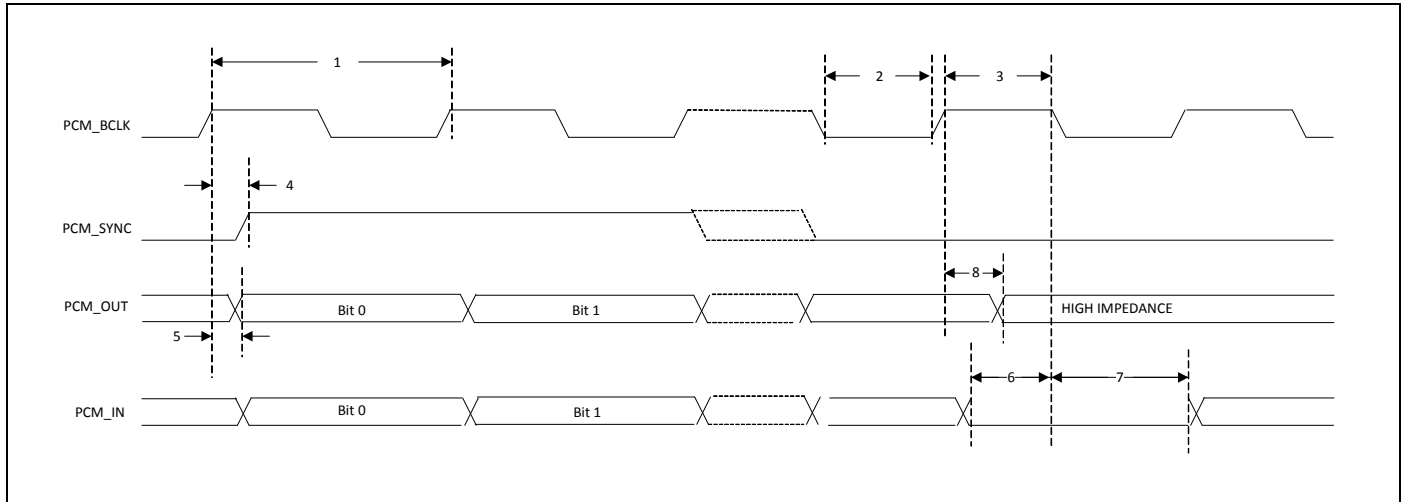


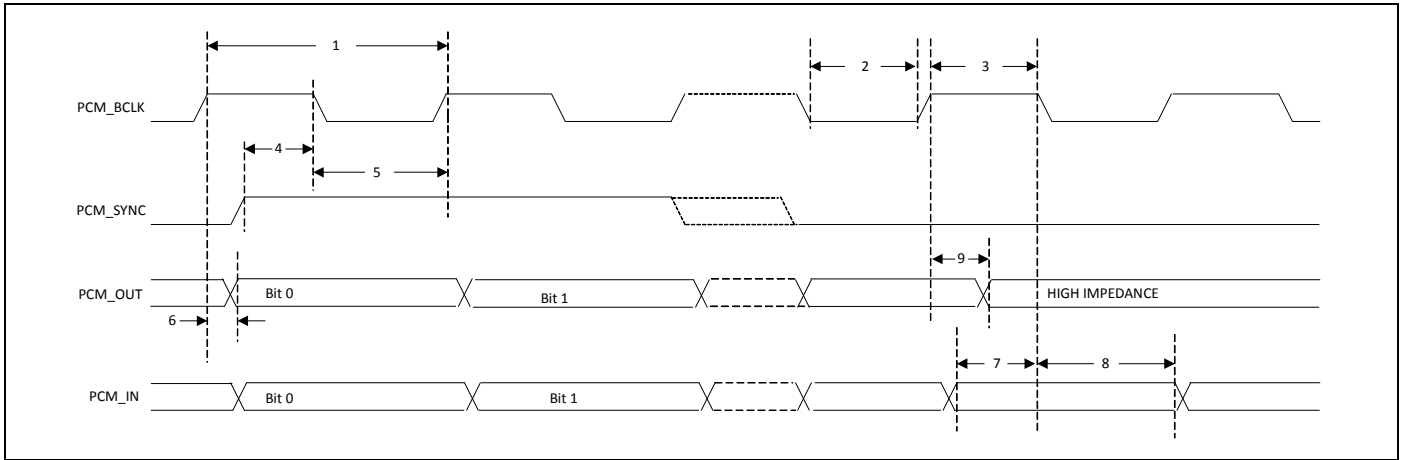
Table 10. PCM Interface Timing Specifications (Long Frame Sync, Master Mode)

Ref No.	Characteristics	Minimum	Typical	Maximum	Unit
1	PCM bit clock frequency	–	–	12	MHz
2	PCM bit clock LOW	41	–	–	ns
3	PCM bit clock HIGH	41	–	–	ns
4	PCM_SYNC delay	0	–	25	ns
5	PCM_OUT delay	0	–	25	ns
6	PCM_IN setup	8	–	–	ns
7	PCM_IN hold	8	–	–	ns
8	Delay from rising edge of PCM_BCLK during last bit period to PCM_OUT becoming high impedance	0	–	25	ns



**Long Frame Sync, Slave Mode**

**Figure 16. PCM Timing Diagram (Long Frame Sync, Slave Mode)**



**Table 11. PCM Interface Timing Specifications (Long Frame Sync, Slave Mode)**

Ref No.	Characteristics	Minimum	Typical	Maximum	Unit
1	PCM bit clock frequency	–	–	12	MHz
2	PCM bit clock LOW	41	–	–	ns
3	PCM bit clock HIGH	41	–	–	ns
4	PCM_SYNC setup	8	–	–	ns
5	PCM_SYNC hold	8	–	–	ns
6	PCM_OUT delay	0	–	25	ns
7	PCM_IN setup	8	–	–	ns
8	PCM_IN hold	8	–	–	ns
9	Delay from rising edge of PCM_BCLK during last bit period to PCM_OUT becoming high impedance	0	–	25	ns

Short Frame Sync, Burst Mode

Figure 17. PCM Burst Mode Timing (Receive Only, Short Frame Sync)

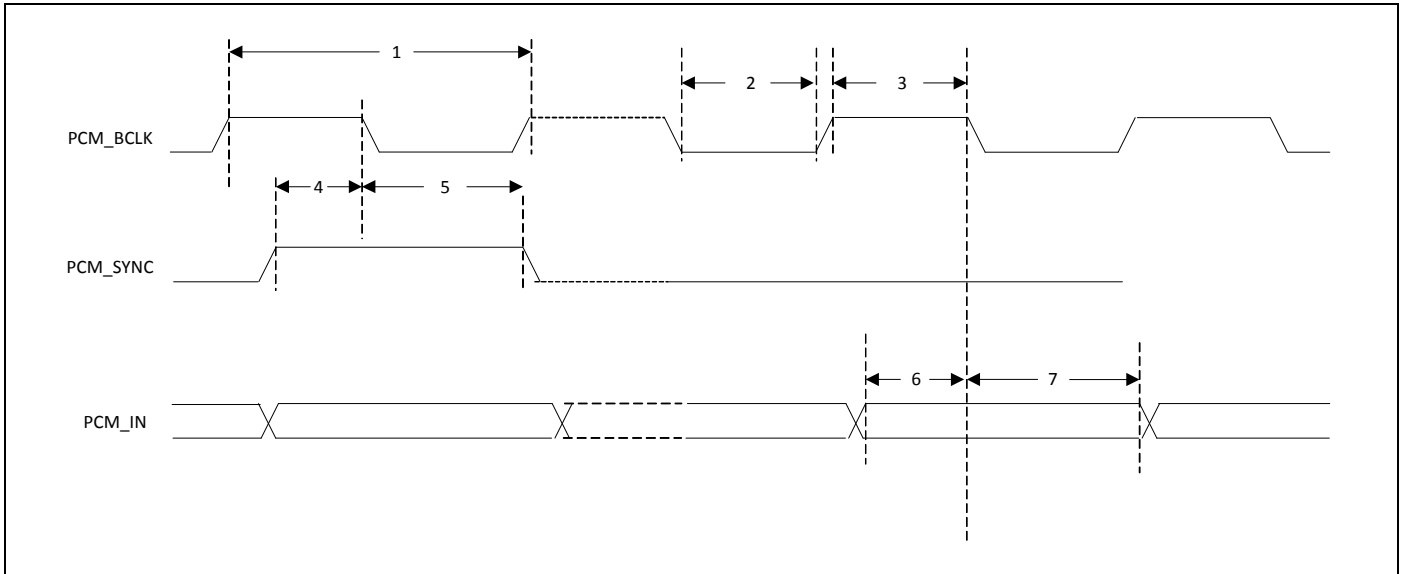


Table 12. PCM Burst Mode (Receive Only, Short Frame Sync)

Ref No.	Characteristics	Minimum	Typical	Maximum	Unit
1	PCM bit clock frequency	–	–	24	MHz
2	PCM bit clock LOW	20.8	–	–	ns
3	PCM bit clock HIGH	20.8	–	–	ns
4	PCM_SYNC setup	8	–	–	ns
5	PCM_SYNC hold	8	–	–	ns
6	PCM_IN setup	8	–	–	ns
7	PCM_IN hold	8	–	–	ns

Long Frame Sync, Burst Mode

Figure 18. PCM Burst Mode Timing (Receive Only, Long Frame Sync)

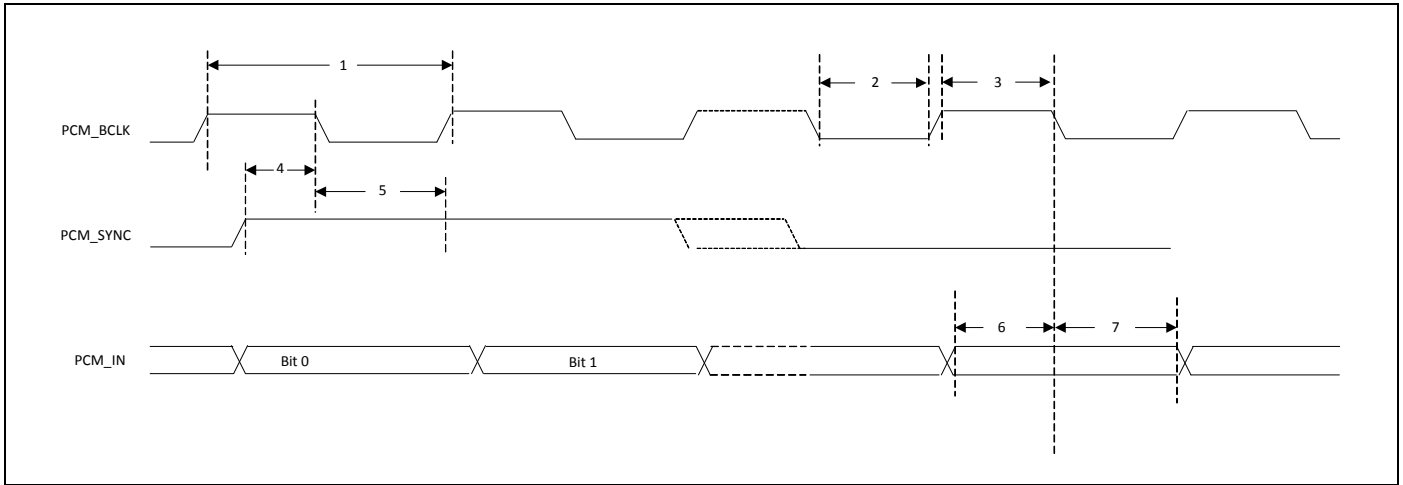


Table 13. PCM Burst Mode (Receive Only, Long Frame Sync)

Ref No.	Characteristics	Minimum	Typical	Maximum	Unit
1	PCM bit clock frequency	–	–	24	MHz
2	PCM bit clock LOW	20.8	–	–	ns
3	PCM bit clock HIGH	20.8	–	–	ns
4	PCM_SYNC setup	8	–	–	ns
5	PCM_SYNC hold	8	–	–	ns
6	PCM_IN setup	8	–	–	ns
7	PCM_IN hold	8	–	–	ns

## 7.4 USB Interface

### 7.4.1 Features

The following USB interface features are supported:

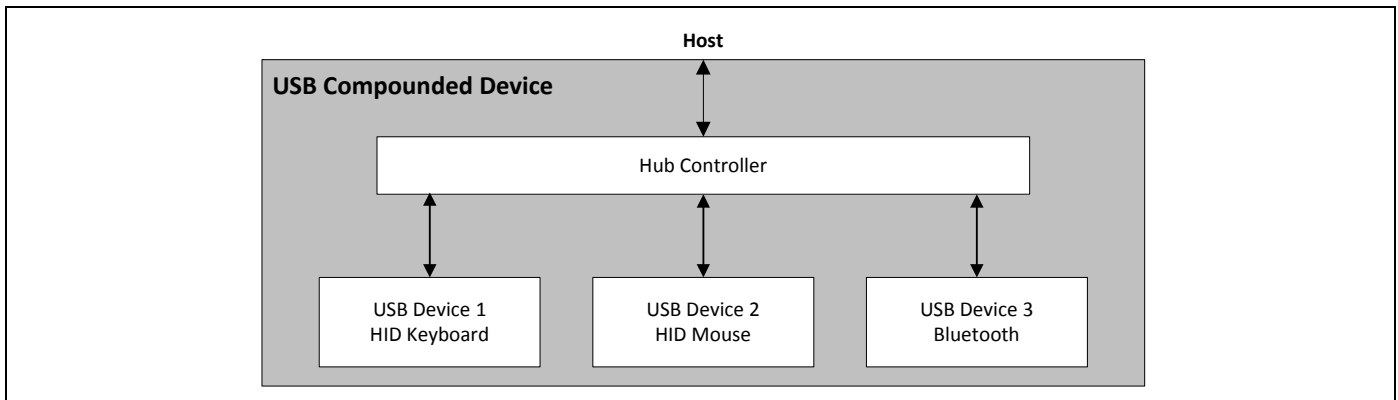
- USB Protocol, Revision 2.0, full-speed (12 Mbps) compliant including the hub
- Optional hub compound device with up to three device cores internal to device
- Bus or self-power, dynamic configuration for the hub
- Global and selective suspend and resume with remote wakeup
- Bluetooth HCI
- HID, DFU, UHE (proprietary method to emulate an HID device at system bootup)
- Integrated detach resistor

### 7.4.2 Operation

When the A4WP feature is *not* used and USB is selected as the Bluetooth interface to the host, an external pull-up (outside the chip) 10 K $\Omega$  resistor to BT\_VDDIO is required. The pull-up is not necessary but is recommended when the Bluetooth/host interface is UART instead of USB.

The CYW4356 can be configured to boot up as either a single USB peripheral or a USB hub with several USB peripherals attached. As a single peripheral, the host detects a single USB Bluetooth device. In hub mode, the host detects a hub with one to three of the ports already connected to USB devices (see [Figure 19](#)).

**Figure 19. USB Compounded Device Configuration**



Depending on the desired hub mode configuration, the CYW4356 can boot up showing the three ports connected to logical USB devices internal to the CYW4356: a generic Bluetooth device, a mouse, and a keyboard. In this mode, the mouse and keyboard are emulated devices, since they connect to real HID devices via a Bluetooth link. The Bluetooth link to these HID devices is hidden from the USB host. To the host, the mouse and/or keyboard appear to be directly connected to the USB port. This Cypress proprietary architecture is called USB HID Emulation (UHE).

The USB device, configuration, and string descriptors are fully programmable, allowing manufacturers to customize the descriptors, including vendor and product IDs, the CYW4356 uses to identify itself on the USB port. To make custom USB descriptor information available at boot time, stored it in external NVRAM.

Despite the mode of operation (single peripheral or hub), the Bluetooth device is configured to include the following interfaces:

<b>Interface 0</b>	Contains a Control endpoint (Endpoint 0x00) for HCI commands, a Bulk In Endpoint (Endpoint 0x82) for receiving ACL data, a Bulk Out Endpoint (Endpoint 0x02) for transmitting ACL data, and an Interrupt Endpoint (Endpoint 0x81) for HCI events.
<b>Interface 1</b>	Contains Isochronous In and Out endpoints (Endpoints 0x83 and 0x03) for SCO traffic. Several alternate Interface 1 settings are available for reserving the proper bandwidth of isochronous data (depending on the application).
<b>Interface 2</b>	Contains Bulk In and Bulk Out endpoints (Endpoints 0x84 and 0x04) used for proprietary testing and debugging purposes. These endpoints can be ignored during normal operation.

### 7.4.3 USB Hub and UHE Support

The CYW4356 supports the USB hub and device model (USB, Revision 2.0, full-speed compliant). Optional mouse and keyboard devices utilize Cypress's proprietary USB HID Emulation (UHE) architecture, which allows these devices appear as standalone HID devices even though connected through a Bluetooth link.

The presence of UHE devices requires the hub to be enabled. The CYW4356 cannot appear as a single keyboard or a single mouse device without the hub. Once either mouse or keyboard UHE device is enabled, the hub must also be enabled.

When the hub is enabled, the CYW4356 handles all standard USB functions for the following devices:

- HID keyboard
- HID mouse
- Bluetooth

All hub and device descriptors are firmware-programmable. This USB compound device configuration (see Figure 19) supports up to three downstream ports. This configuration can also be programmed to a single USB device core. The device automatically detects activity on the USB interface when connected. Therefore, no special configuration is needed to select HCI as the transport.

The hub's downstream port definition is as follows:

- Port 1 USB lite device core (for HID applications)
- Port 2 USB lite device core (for HID applications)
- Port 3 USB full device core (for Bluetooth applications)

When operating in hub mode, all three internal devices do not have to be enabled. Each internal USB device can be optionally enabled. The configuration record in NVRAM determines which devices are present.

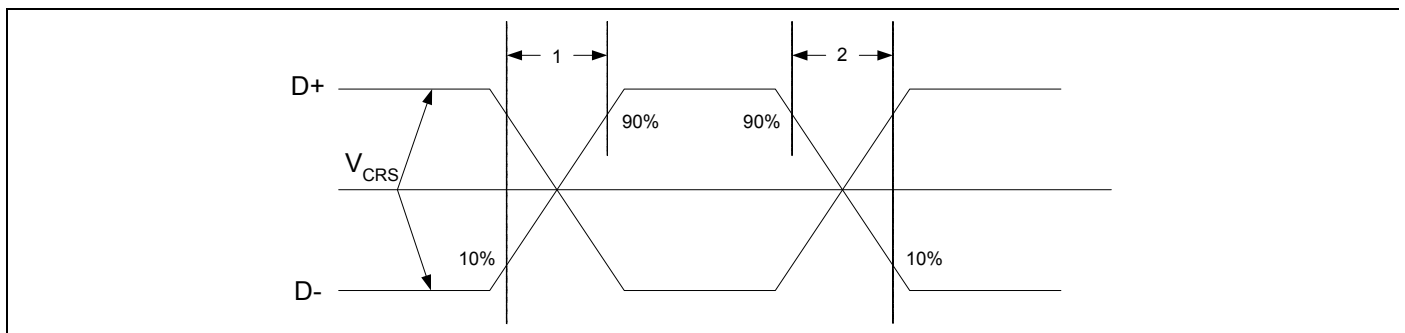
### 7.4.4 USB Full-Speed Timing

Table 14 shows timing specifications for the  $V_{DD\_USB} = 3.3V$ ,  $V_{SS} = 0V$ , and  $T_A = 0^\circ C$  to  $85^\circ C$  operating temperature range.

**Table 14. USB Full-Speed Timing Specifications**

Reference	Characteristics	Minimum	Maximum	Unit
1	Transition rise time	4	20	ns
2	Transition fall time	4	20	ns
3	Rise/fall timing matching	90	111	%
4	Full-speed data rate	12 - 0.25%	12 + 0.25%	Mb/s

**Figure 20. USB Full-Speed Timing**



**7.5 UART Interface**

The CYW4356 shares a single UART for Bluetooth and FM. The UART is a standard 4-wire interface (RX, TX, RTS, and CTS) with adjustable baud rates from 9600 bps to 4.0 Mbps. The interface features an automatic baud rate detection capability that returns a baud rate selection. Alternatively, the baud rate may be selected through a vendor-specific UART HCI command.

UART has a 1040-byte receive FIFO and a 1040-byte transmit FIFO to support EDR. Access to the FIFOs is conducted through the AHB interface through either DMA or the CPU. The UART supports the Bluetooth 4.1 UART HCI specification: H4, a custom Extended H4, and H5. The default baud rate is 115.2 Kbaud.

The UART supports the 3-wire H5 UART transport, as described in the Bluetooth specification (“Three-wire UART Transport Layer”). Compared to H4, the H5 UART transport reduces the number of signal lines required by eliminating the CTS and RTS signals.

The CYW4356 UART can perform XON/XOFF flow control and includes hardware support for the Serial Line Input Protocol (SLIP). It can also perform wake-on activity. For example, activity on the RX or CTS inputs can wake the chip from a sleep state.

Normally, the UART baud rate is set by a configuration record downloaded after device reset, or by automatic baud rate detection, and the host does not need to adjust the baud rate. Support for changing the baud rate during normal HCI UART operation is included through a vendor-specific command that allows the host to adjust the contents of the baud rate registers. The CYW4356 UARTs operate correctly with the host UART as long as the combined baud rate error of the two devices is within ±2%.

**Table 15. Example of Common Baud Rates**

Desired Rate	Actual Rate	Error (%)
4000000	4000000	0.00
3692000	3692308	0.01
3000000	3000000	0.00
2000000	2000000	0.00
1500000	1500000	0.00
1444444	1454544	0.70
921600	923077	0.16
460800	461538	0.16
230400	230796	0.17
115200	115385	0.16
57600	57692	0.16
38400	38400	0.00
28800	28846	0.16
19200	19200	0.00
14400	14423	0.16
9600	9600	0.00

Figure 21. UART Timing

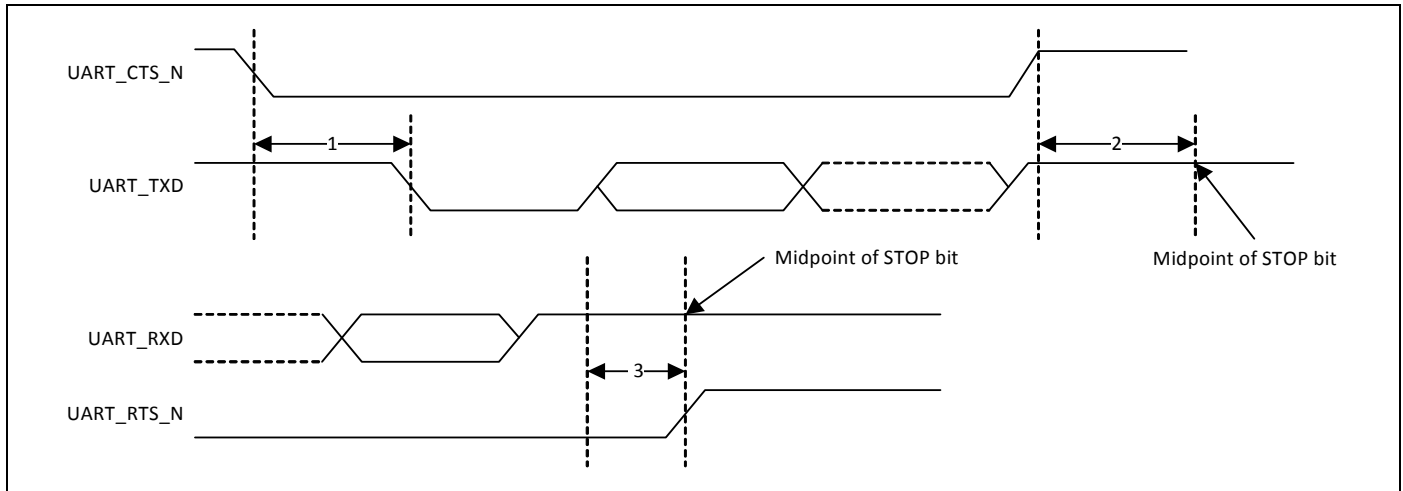


Table 16. UART Timing Specifications

Ref No.	Characteristics	Min.	Typ.	Max.	Unit
1	Delay time, UART_CTS_N low to UART_TXD valid	–	–	1.5	Bit periods
2	Setup time, UART_CTS_N high before midpoint of stop bit	–	–	0.5	Bit periods
3	Delay time, midpoint of stop bit to UART_RTS_N high	–	–	0.5	Bit periods

### 7.6 I<sup>2</sup>S Interface

The CYW4356 supports two independent I<sup>2</sup>S digital audio ports: one for Bluetooth audio, and one for high-fidelity FM audio. The I<sup>2</sup>S interface for FM audio supports both master and slave modes. The I<sup>2</sup>S signals are:

- I<sup>2</sup>S clock: BT\_I2S\_CLK
- I<sup>2</sup>S Word Select: BT\_I2S\_WS
- I<sup>2</sup>S Data Out: BT\_I2S\_DO
- I<sup>2</sup>S Data In: BT\_I2S\_DI

BT\_I2S\_CLK and BT\_I2S\_WS become outputs in master mode and inputs in slave mode, whereas BT\_I2S\_DO always stays as an output. The channel word length is 16 bits, and the data is justified so that the MSB of the left-channel data is aligned with the MSB of the I<sup>2</sup>S bus, in accord with the I<sup>2</sup>S specification. The MSB of each data word is transmitted one bit clock cycle after the BT\_I2S\_WS transition, synchronous with the falling edge of the bit clock. Left-channel data is transmitted when BT\_I2S\_WS is low, and right-channel data is transmitted when BT\_I2S\_WS is high. Data bits sent by the CYW4356 are synchronized with the falling edge of BT\_I2S\_CLK and should be sampled by the receiver on the rising edge of BT\_I2S\_CLK.

The clock rate in master mode is either of the following:

- 48 kHz x 32 bits per frame = 1.536 MHz
- 48 kHz x 50 bits per frame = 2.400 MHz

The master clock is generated from the input reference clock using a N/M clock divider.

In the slave mode, any clock rate is supported to a maximum of 3.072 MHz.

7.6.1 I<sup>2</sup>S Timing

**Note:** Timing values specified in Table 17 are relative to high and low threshold levels.

**Table 17. Timing for I<sup>2</sup>S Transmitters and Receivers**

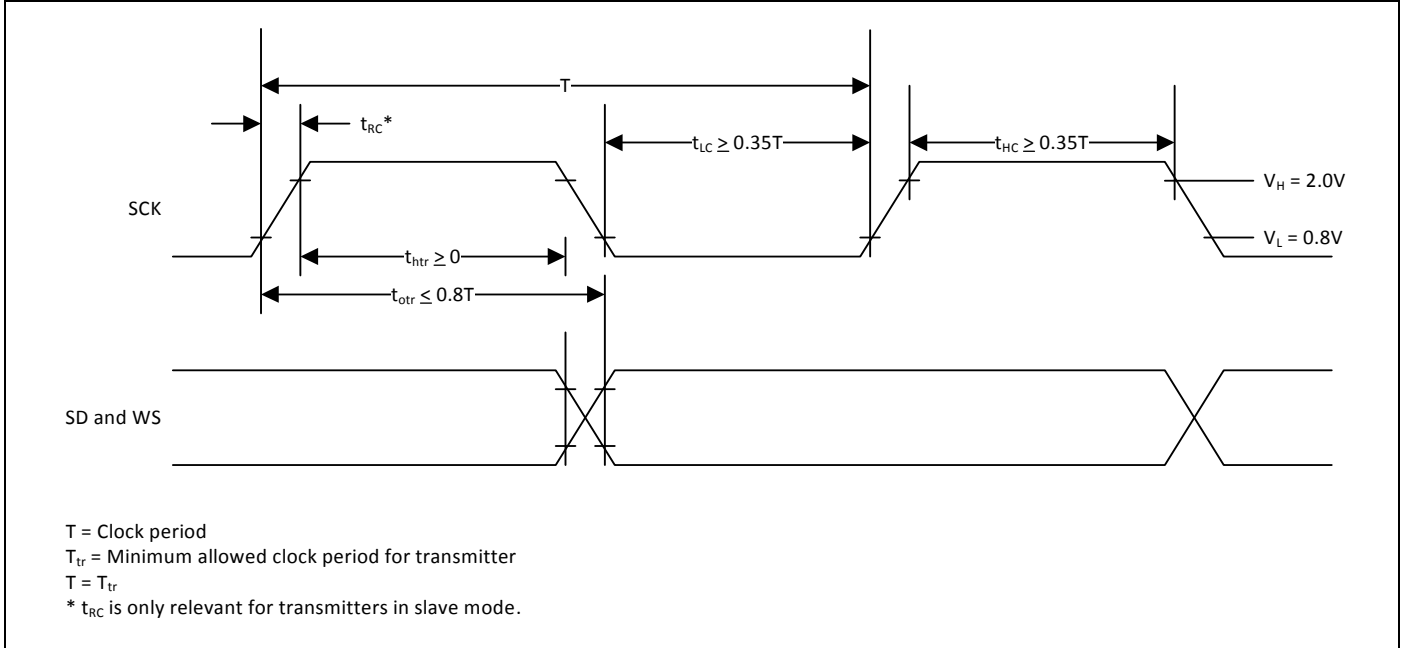
	Transmitter				Receiver				Notes
	Lower Limit		Upper Limit		Lower Limit		Upper Limit		
	Min.	Max.	Min.	Max.	Min.	Max.	Min.	Max.	
Clock Period T	T <sub>tr</sub>	–	–	–	T <sub>r</sub>	–	–	–	a
<b>Master Mode: Clock generated by transmitter or receiver</b>									
HIGH t <sub>HC</sub>	0.35T <sub>tr</sub>	–	–	–	0.35T <sub>tr</sub>	–	–	–	b
LOW t <sub>LC</sub>	0.35T <sub>tr</sub>	–	–	–	0.35T <sub>tr</sub>	–	–	–	b
<b>Slave Mode: Clock accepted by transmitter or receiver</b>									
HIGH t <sub>HC</sub>	–	0.35T <sub>tr</sub>	–	–	–	0.35T <sub>tr</sub>	–	–	c
LOW t <sub>LC</sub>	–	0.35T <sub>tr</sub>	–	–	–	0.35T <sub>tr</sub>	–	–	c
Rise time t <sub>RC</sub>	–	–	0.15T <sub>tr</sub>	–	–	–	–	–	d
<b>Transmitter</b>									
Delay t <sub>dtr</sub>	–	–	–	0.8T	–	–	–	–	e
Hold time t <sub>htr</sub>	0	–	–	–	–	–	–	–	d
<b>Receiver</b>									
Setup time t <sub>sr</sub>	–	–	–	–	–	0.2T <sub>r</sub>	–	–	f
Hold time t <sub>hr</sub>	–	–	–	–	–	0	–	–	f

- a. The system clock period T must be greater than T<sub>tr</sub> and T<sub>r</sub> because both the transmitter and receiver have to be able to handle the data transfer rate.
- b. At all data rates in master mode, the transmitter or receiver generates a clock signal with a fixed mark/space ratio. For this reason, t<sub>HC</sub> and t<sub>LC</sub> are specified with respect to T.
- c. In slave mode, the transmitter and receiver need a clock signal with minimum HIGH and LOW periods so that they can detect the signal. So long as the minimum periods are greater than 0.35T<sub>r</sub>, any clock that meets the requirements can be used.
- d. Because the delay (t<sub>dtr</sub>) and the maximum transmitter speed (defined by T<sub>tr</sub>) are related, a fast transmitter driven by a slow clock edge can result in t<sub>dtr</sub> not exceeding t<sub>RC</sub> which means t<sub>htr</sub> becomes zero or negative. Therefore, the transmitter has to guarantee that t<sub>htr</sub> is greater than or equal to zero, so long as the clock rise-time t<sub>RC</sub> is not more than t<sub>RCmax</sub>, where t<sub>RCmax</sub> is not less than 0.15T<sub>tr</sub>.
- e. To allow data to be clocked out on a falling edge, the delay is specified with respect to the rising edge of the clock signal and T, always giving the receiver sufficient setup time.
- f. The data setup and hold time must not be less than the specified receiver setup and hold time.

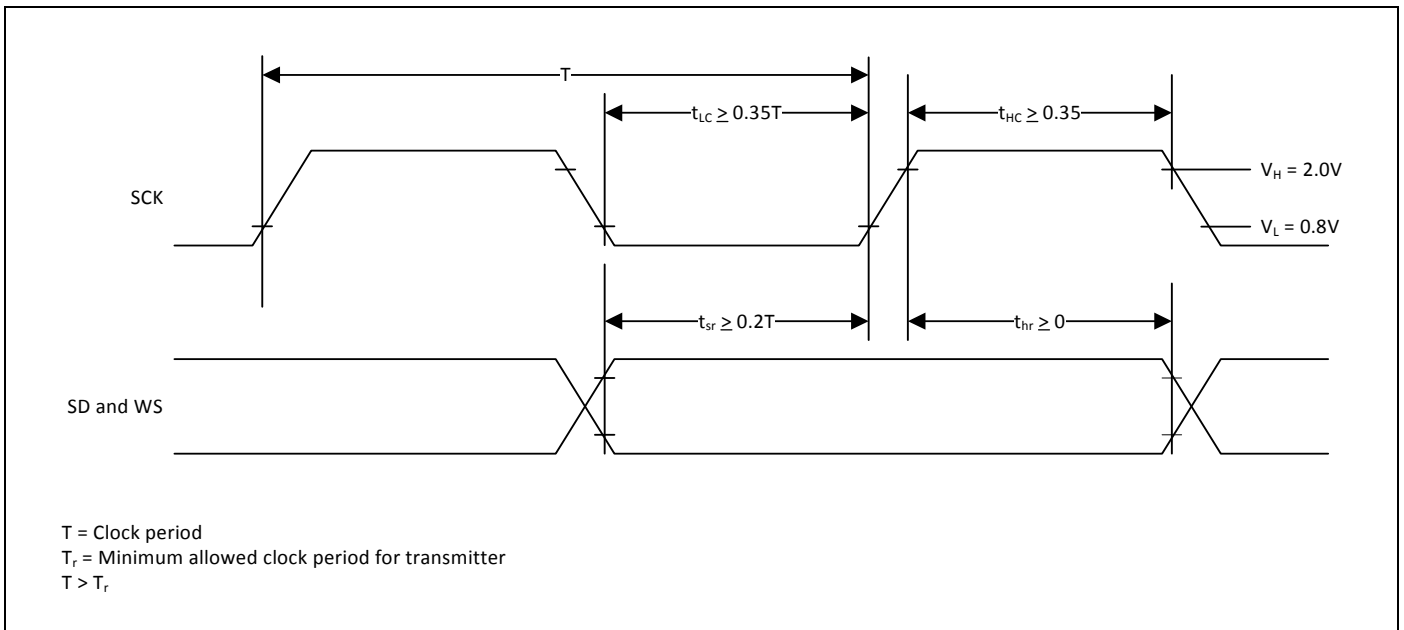


**Note:** The time periods specified in Figure 22 and Figure 23 are defined by the transmitter speed. The receiver specifications must match transmitter performance.

**Figure 22. I<sup>2</sup>S Transmitter Timing**



**Figure 23. I<sup>2</sup>S Receiver Timing**



## 8. FM Receiver Subsystem

### 8.1 FM Radio

The CYW4356 includes a completely integrated FM radio receiver with RDS/RBDS covering all FM bands from 65 MHz to 108 MHz. The receiver is controlled through commands on the HCI. FM received audio is available as stereo or in digital form through I<sup>2</sup>S or PCM. The FM radio operates from the external clock reference.

### 8.2 Digital FM Audio Interfaces

The FM audio can be transmitted via the shared PCM and I<sup>2</sup>S pins, and the sampling rate is programmable. The CYW4356 supports a three-wire PCM or I<sup>2</sup>S audio interface in either master or slave configuration. The master or slave configuration is selected using vendor specific commands over the HCI interface. In addition, multiple sampling rates are supported, derived from either the FM or Bluetooth clocks. In master mode, the clock rate is either of the following:

- 48 kHz × 32 bits per frame = 1.536 MHz
- 48 kHz × 50 bits per frame = 2.400 MHz

In slave mode, any clock rate is supported up to a maximum of 3.072 MHz.

### 8.3 FM Over Bluetooth

The CYW4356 can output received FM audio onto Bluetooth using one of following three links: eSCO, WBS, and A2DP. In all of the above modes, once the link has been set up, the host processor can enter sleep mode while the CYW4356 continues to stream FM audio to the remote Bluetooth device, allowing the system current consumption to be minimized.

### 8.4 eSCO

In this use case, the stereo FM audio is downsampled to 8 kHz and a mono or stereo stream is then sent through the Bluetooth eSCO link to a remote Bluetooth device, typically a headset. Two Bluetooth voice connections must be used to transport stereo.

### 8.5 Wideband Speech Link

In this case, the stereo FM audio is downsampled to 16 kHz and a mono or stereo stream is then sent through the Bluetooth wideband speech link to a remote Bluetooth device, typically a headset. Two Bluetooth voice connections must be used to transport stereo.

### 8.6 A2DP

In this case, the stereo FM audio is encoded by the on-chip SBC encoder and transported as an A2DP link to a remote Bluetooth device. Sampling rates of 48 kHz, 44.1 kHz, and 32 kHz joint stereo are supported. An A2DP “lite” stack is implemented in the CYW4356 to support this use case, which eliminates the need to route the SBC-encoded audio back to the host to create the A2DP packets.

### 8.7 Autotune and Search Algorithms

The CYW4356 supports a number of FM search and tune functions that allows the host to implement many convenient user functions, which are accessed through the Cypress FM stack.

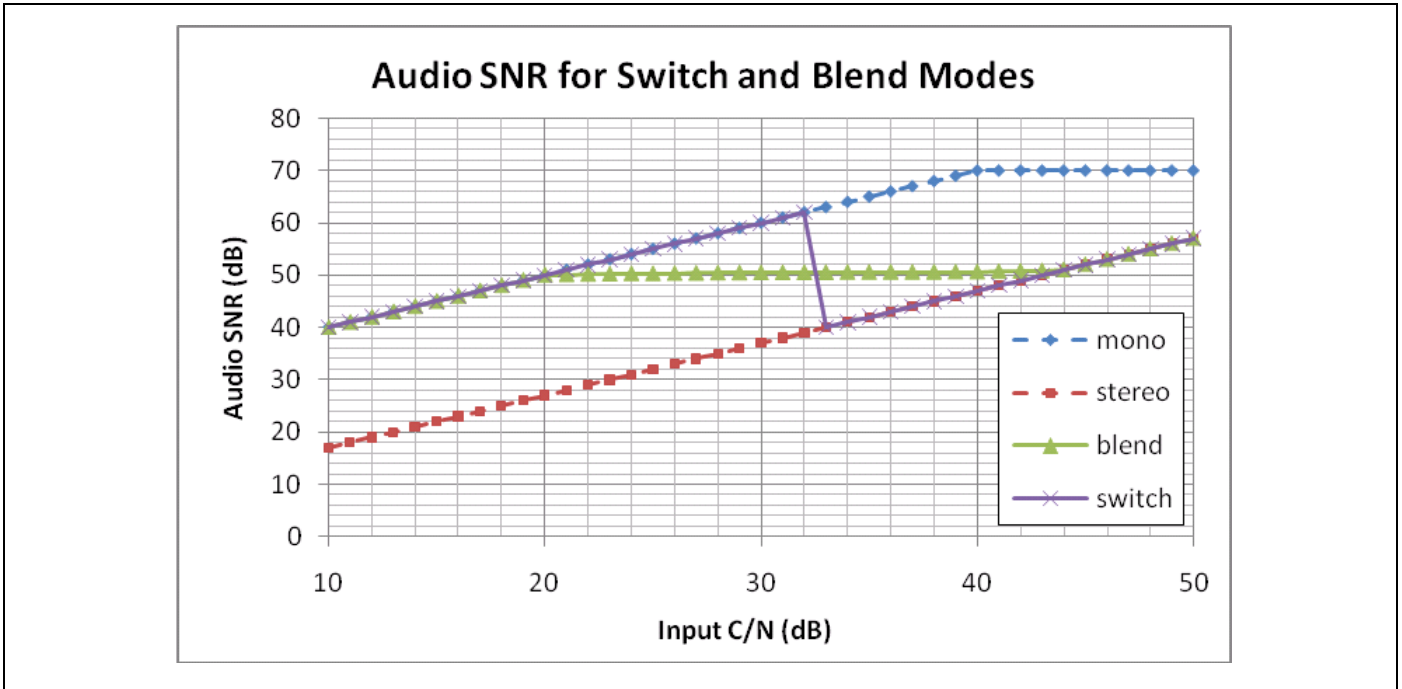
- Tune to Play: Allows the FM receiver to be programmed to a specific frequency.
- Search for SNR > Threshold: Checks the power level of the available channel and the estimated SNR of the channel to help achieve precise control of the expected sound quality for the selected FM channel. Specifically, the host can adjust its SNR requirements to retrieve a signal with a specific sound quality, or adjust this to return the weakest channels.
- Alternate Frequency Jump: Allows the FM receiver to automatically jump to an alternate FM channel that carries the same information, but has a better SNR. For example, when traveling, a user may pass through a region where a number of channels carry the same station. When the user passes from one area to the next, the FM receiver can automatically switch to another channel with a stronger signal to spare the user from having to manually change the channel to continue listening to the same station.

### 8.8 Audio Features

A number of features are implemented in the CYW4356 to provide the best possible audio experience for the user.

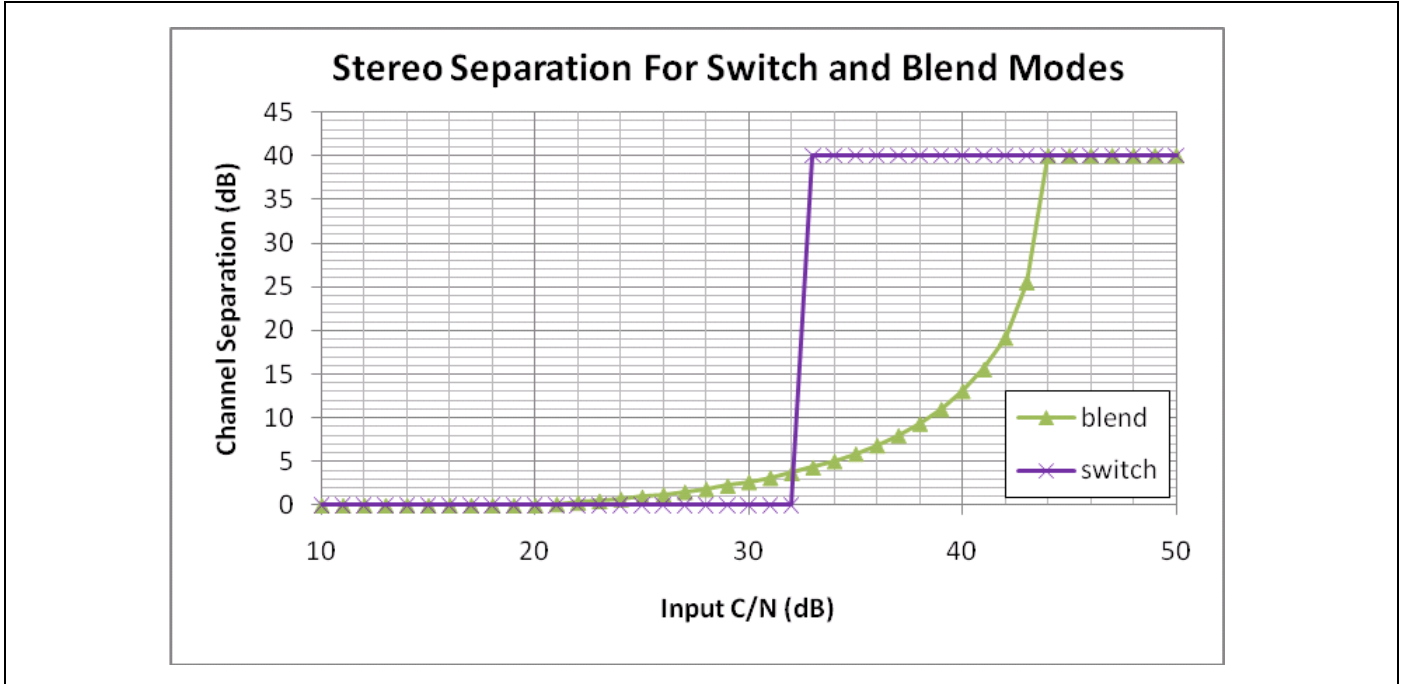
- Mono/Stereo Blend or Switch: The CYW4356 provides automatic control of the stereo or mono settings based on the FM signal carrier-to-noise ratio (C/N). This feature is used to maintain the best possible audio SNR based on the FM channel condition. Two modes of operation are supported:
  - Blend: In this mode, fine control of stereo separation is used to achieve optimal audio quality over a wide range of input C/N. The amount of separation is fully programmable. In Figure 24, the separation is programmed to maintain a minimum 50 dB SNR across the blend range.
  - Extended blend: In this mode, stereo separation is maximized across a wide range of input CNR. Cypress static suppression typically gives a static-free user experience to within 3 dB of ultimate sensitivity.

Figure 24. Example Blend/Switch Usage



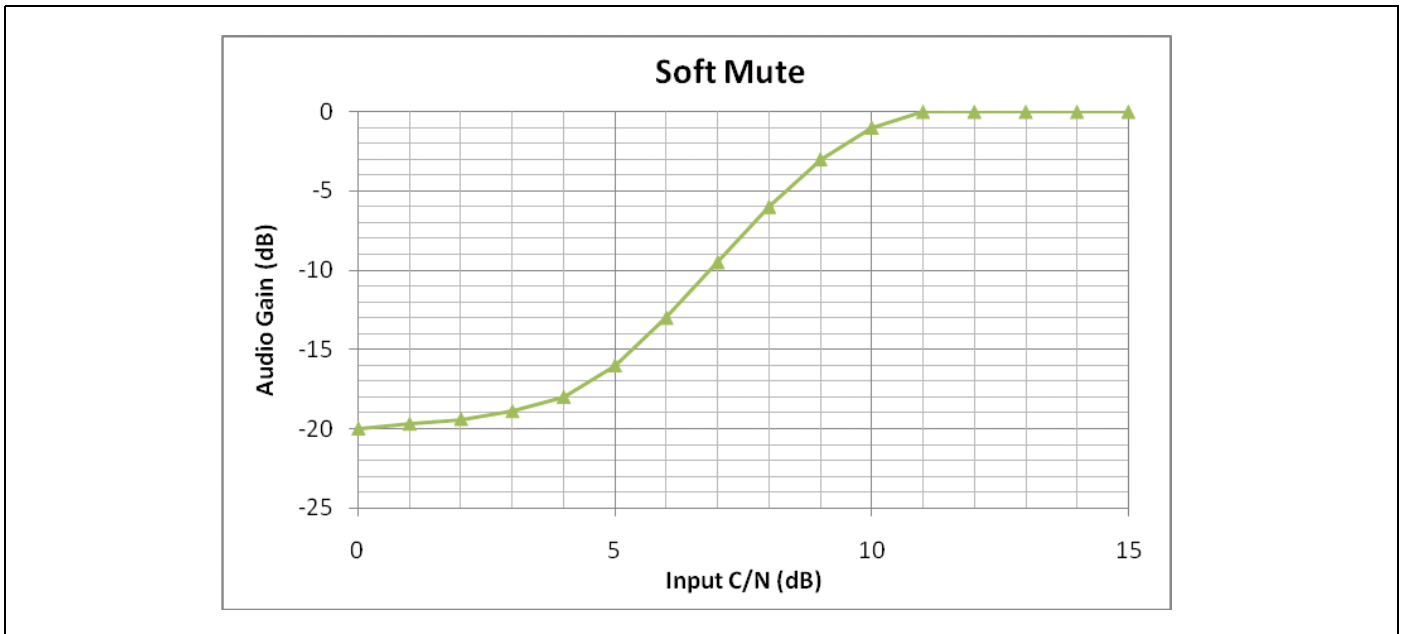
- Switch: In this mode, the audio switches from full stereo to full mono at a predetermined level to maintain optimal audio quality. The stereo-to-mono switch point and the mono-to-stereo switch points are fully programmable to provide the desired amount of audio SNR. In Figure 25, the switch point is programmed to switch to mono to maintain a 40 dB SNR.

Figure 25. Example Blend/Switch Separation



- Soft Mute: Improves the user experience by dynamically muting the output audio proportionate to the FM signal C/N. This prevents the user from being assaulted with a blast of static. The mute characteristic is fully programmable to accommodate fine tuning of the output signal level. An example mute characteristic is shown in Figure 26.

Figure 26. Example Soft Mute Characteristic



- **High Cut:** A programmable high-cut filter is provided to reduce the amount of high-frequency noise caused by static in the output audio signal. Like the soft mute circuit, it is fully programmable to allow for any amount of high cut based on the FM signal C/N.
- **Audio Pause Detect:** The FM receiver monitors the magnitude of the audio signal and notifies the host through an interrupt when the magnitude of the signal has fallen below the threshold set for a programmable period. This feature can be used to provide alternate frequency jumps during periods of silence to minimize disturbances to the listener. Filtering techniques are used within the audio pause detection block to provide more robust presence-to-silence detection and silence-to-presence detection.
- **Automatic Antenna Tuning:** The CYW4356 has an on-chip automatic antenna tuning network. When used with a single off-chip inductor, the on-chip circuitry automatically chooses an optimal on-chip matching component to obtain the highest signal strength for the desired frequency. The high-Q nature of this matching network simultaneously provides out-of-band blocking protection as well as a reduction of radiated spurious emissions from the FM antenna. It is designed to accommodate a wide range of external wire antennas.

## 8.9 RDS/RBDS

The CYW4356 integrates a RDS/RBDS modem and codec, the decoder includes programmable filtering and buffering functions, and the encoder includes the option to encode messages to PS or RT frame format with programmable scrolling in PS mode. The RDS/RBDS data can be read out in receive mode or delivered in transmit mode through either the HCI interface.

In addition, the RDS/RBDS functionality supports the following:

### Receive

- Block decoding, error correction and synchronization
- Flywheel synchronization feature, allowing the host to set parameters for acquisition, maintenance, and loss of sync. (It is possible to set up the CYW4356 such that synch is achieved when a minimum of two good blocks (error free) are decoded in sequence. The number of good blocks required for sync is programmable.)
- Storage capability up to 126 blocks of RDS data
- Full or partial block B match detect and interrupt to host
- Audio pause detection with programmable parameters
- Program Identification (PI) code detection and interrupt to host
- Automatic frequency jump
- Block E filtering
- Soft mute
- Signal dependent mono/stereo blend
- Programmable preemphasis

## 9. WLAN Global Functions

### 9.1 WLAN CPU and Memory Subsystem

The CYW4356 WLAN section includes an integrated ARM Cortex-R4 32-bit processor with internal RAM and ROM. The ARM Cortex-R4 is a low-power processor that features low gate count, low interrupt latency, and low-cost debug capabilities. It is intended for deeply embedded applications that require fast interrupt response features. Delivering a performance gain of more than 30% over the ARM7TDMI processor, the ARM Cortex-R4 processor implements the ARM v7-R architecture with support for the Thumb-2 instruction set.

At 0.19  $\mu\text{W}/\text{MHz}$ , the Cortex-R4 is the most power efficient general-purpose microprocessor available, outperforming 8- and 16-bit devices on MIPS/ $\mu\text{W}$ .

Using multiple technologies to reduce cost, the ARM Cortex-R4 offers improved memory utilization, reduced pin overhead, and reduced silicon area. It supports independent buses for Code and Data access (ICode/DCode and System buses), integrated sleep modes, and extensive debug features including real time trace of program execution.

On-chip memory for the CPU includes 768 KB SRAM and 640 KB ROM.

### 9.2 One-Time Programmable Memory

Various hardware configuration parameters may be stored in an internal One-Time Programmable (OTP) memory, which is read by the system software after device reset. In addition, customer-specific parameters, including the system vendor ID and the MAC address can be stored, depending on the specific board design. Up to 484 bytes of user-accessible OTP are available.

The initial state of all bits in an unprogrammed OTP device is 0. After any bit is programmed to a 1, it cannot be reprogrammed to 0. The entire OTP array can be programmed in a single write cycle using a utility provided with the Cypress WLAN manufacturing test tools. Alternatively, multiple write cycles can be used to selectively program specific bytes, but only bits which are still in the 0 state can be altered during each programming cycle.

Prior to OTP programming, all values should be verified using the appropriate editable nvram.txt file, which is provided with the reference board design package.

### 9.3 GPIO Interface

The CYW4356 has 11 general-purpose I/O (GPIO) pins in the WLAN section that can be used to connect to various external devices.

Upon power-up and reset, these pins become tristated. Subsequently, they can be programmed to be either input or output pins via the GPIO control register. In addition, the GPIO pins can be assigned to various other functions, see [Table 27](#).

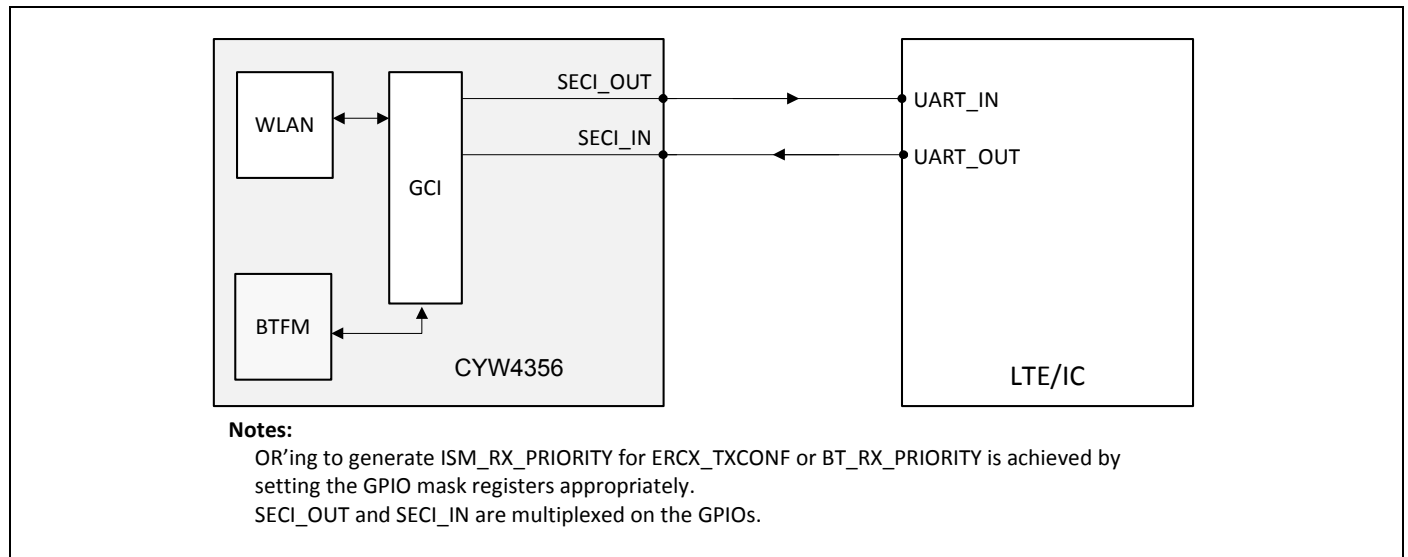
### 9.4 External Coexistence Interface

An external handshake interface is available to enable signaling between the device and an external co-located wireless device, such as GPS, LTE, or UWB, to manage wireless medium sharing for optimal performance.

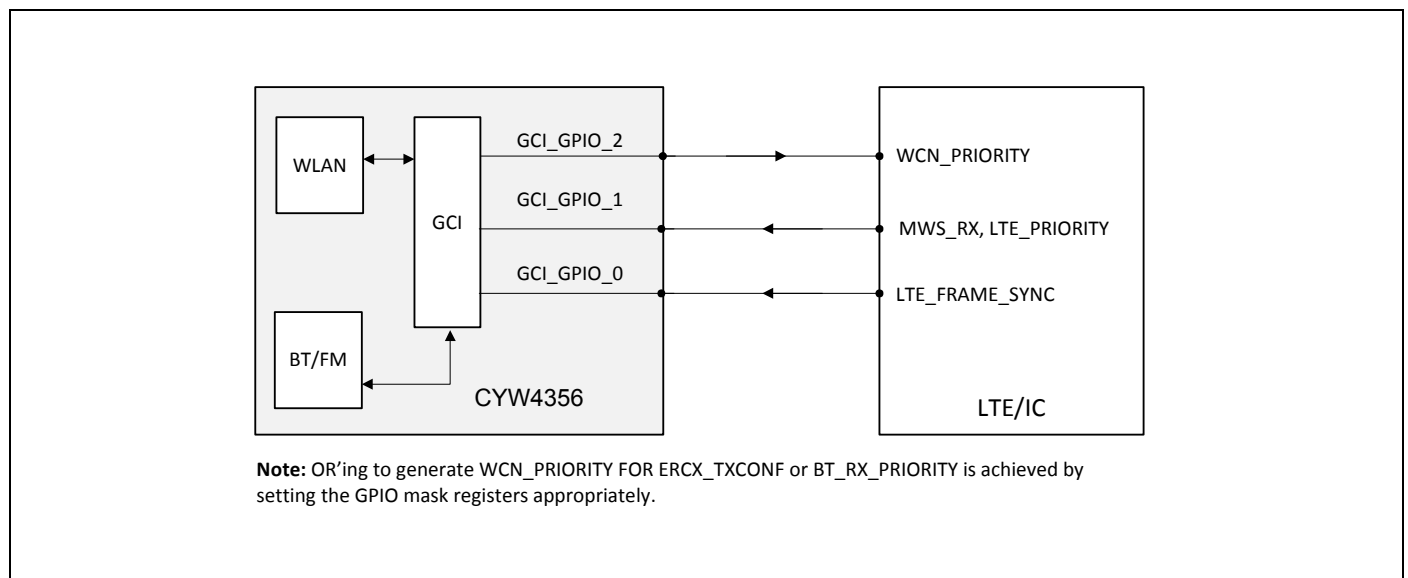
Figure 27 and Figure 28 show the LTE coexistence interface (including UART) for each CYW4356 package type. See Table 27 for further details on multiplexed signals, such as the GPIO pins.

See Table 16 for the UART baud rate.

**Figure 27. Cypress GCI Mode LTE Coexistence Interface**



**Figure 28. Legacy 3-Wire LTE Coexistence Interface**



### 9.5 UART Interface

One 2-wire UART interface can be enabled by software as an alternate function on GPIO pins. Refer to [Table 27](#). Provided primarily for debugging during development, this UART enables the CYW4356 to operate as RS-232 data termination equipment (DTE) for exchanging and managing data with other serial devices. It is compatible with the industry standard 16550 UART, and provides a FIFO size of 64 × 8 in each direction.

### 9.6 JTAG Interface

The CYW4356 supports the IEEE 1149.1 JTAG boundary scan standard for performing device package and PCB assembly testing during manufacturing. In addition, the JTAG interface allows Cypress to assist customers by using proprietary debug and characterization test tools during board bring-up. Therefore, it is highly recommended to provide access to the JTAG pins by means of test points or a header on all PCB designs.

Refer to [Table 27](#) for JTAG pin assignments.

### 9.7 SPROM Interface

Various hardware configuration parameters may be stored in an external SPROM instead of the OTP. The SPROM is read by system software after device reset. In addition, depending on the board design, customer-specific parameters may be stored in SPROM.

The four SPROM control signals —SPROM\_CS, SPROM\_CLK, SPROM\_MI, and SPROM\_MO are multiplexed on the SDIO interface (see [Table 27](#) for additional details). By default, the SPROM interface supports 2 Kbit serial SPROMs, and it can also support 4 Kbit and 16 Kbit serial SPROMs by using the appropriate strapping option.



## 10. WLAN Host Interfaces

### 10.1 SDIO v3.0

All three package options of the CYW4356 WLAN section provide support for SDIO version 3.0, including the new UHS-I modes:

- DS: Default speed (DS) up to 25 MHz, including 1- and 4-bit modes (3.3V signaling).
- HS: High-speed up to 50 MHz (3.3V signaling).
- SDR12: SDR up to 25 MHz (1.8V signaling).
- SDR25: SDR up to 50 MHz (1.8V signaling).
- SDR50: SDR up to 100 MHz (1.8V signaling).
- SDR104: SDR up to 208 MHz (1.8V signaling)
- DDR50: DDR up to 50 MHz (1.8V signaling).

**Note:** The CYW4356 is backward compatible with SDIO v2.0 host interfaces.

The SDIO interface also has the ability to map the interrupt signal on to a GPIO pin for applications requiring an interrupt different from the one provided by the SDIO interface. The ability to force control of the gated clocks from within the device is also provided. SDIO mode is enabled by strapping options. Refer to [Table 24](#) WLAN GPIO Functions and Strapping Options.

The following three functions are supported:

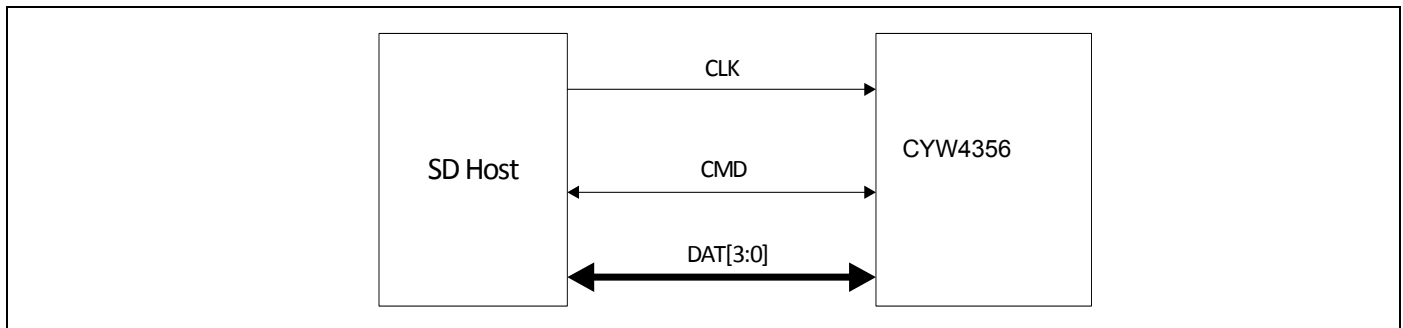
- Function 0 Standard SDIO function (max. BlockSize/ByteCount = 32B)
- Function 1 Backplane Function to access the internal system-on-chip (SoC) address space (max. BlockSize/ByteCount = 64B)
- Function 2 WLAN Function for efficient WLAN packet transfer through DMA (max. BlockSize/ByteCount = 512B)

#### 10.1.1 SDIO Pins

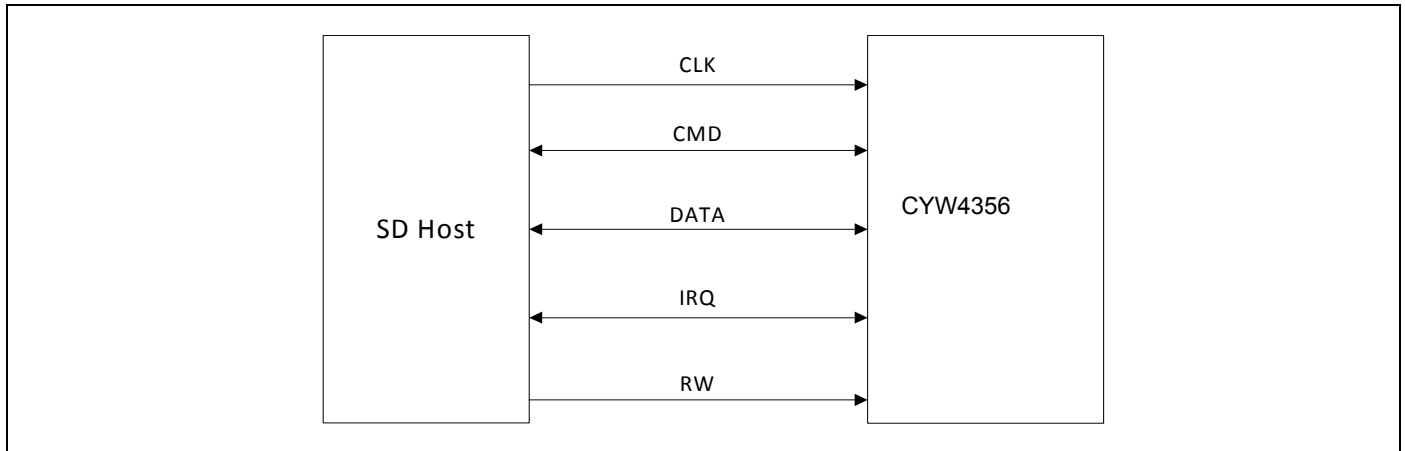
**Table 18. SDIO Pin Descriptions**

SD 4-Bit Mode		SD 1-Bit Mode	
DATA0	Data line 0	DATA	Data line
DATA1	Data line 1 or Interrupt	IRQ	Interrupt
DATA2	Data line 2 or Read Wait	RW	Read Wait
DATA3	Data line 3	N/C	Not used
CLK	Clock	CLK	Clock
CMD	Command line	CMD	Command line

**Figure 29. Signal Connections to SDIO Host (SD 4-Bit Mode)**



**Figure 30. Signal Connections to SDIO Host (SD 1-Bit Mode)**



**Note:** Per Section 6 of the SDIO specification, pull-ups in the 10 kΩ to 100 kΩ range are required on the four DATA lines and the CMD line. This requirement must be met during all operating states either through the use of external pull-up resistors or through proper programming of the SDIO host's internal pull-ups.

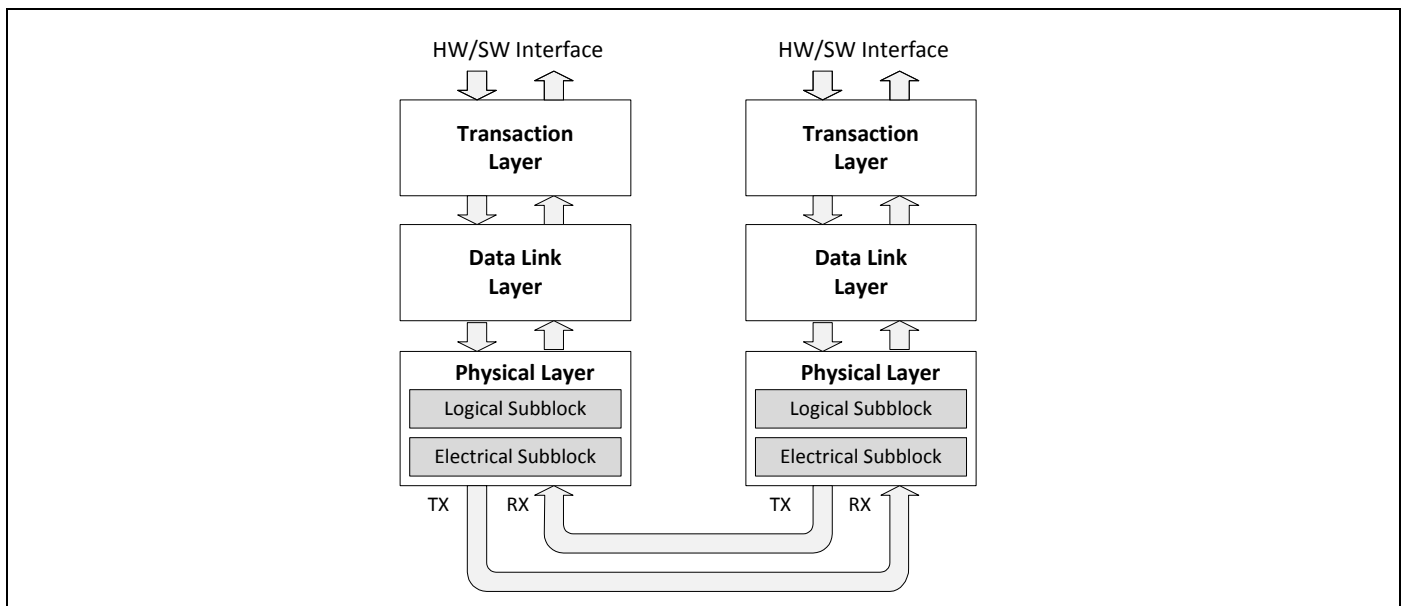
## 10.2 PCI Express Interface

The PCI Express (PCIe) core on the CYW4356 is a high-performance serial I/O interconnect that is protocol compliant and electrically compatible with the *PCI Express Base Specification v3.0* running at Gen1 speeds. This core contains all the necessary blocks, including logical and electrical functional subblocks to perform PCIe functionality and maintain high-speed links, using existing PCI system configuration software implementations without modification.

Organization of the PCIe core is in logical layers: Transaction Layer, Data Link Layer, and Physical Layer, as shown in Figure 31. A configuration or link management block is provided for enumerating the PCIe configuration space and supporting generation and reception of System Management Messages by communicating with PCIe layers.

Each layer is partitioned into dedicated transmit and receive units that allow point-to-point communication between the host and CYW4356 device. The transmit side processes outbound packets whereas the receive side processes inbound packets. Packets are formed and generated in the Transaction and Data Link Layer for transmission onto the high-speed links and onto the receiving device. A header is added at the beginning to indicate the packet type and any other optional fields.

**Figure 31. PCI Express Layer Model**



### 10.2.1 Transaction Layer Interface

The PCIe core employs a packet-based protocol to transfer data between the host and CYW4356 device, delivering new levels of performance and features. The upper layer of the PCIe is the Transaction Layer. The Transaction layer is primarily responsible for assembly and disassembly of Transaction Layer Packets (TLPs). TLP structure contains header, data payload, and End-to-End CRC (ECRC) fields, which are used to communicate transactions, such as read and write requests and other events.

A pipelined full split-transaction protocol is implemented in this layer to maximize efficient communication between devices with credit-based flow control of TLP, which eliminates wasted link bandwidth due to retries.

### 10.2.2 Data Link Layer

The data link layer serves as an intermediate stage between the transaction layer and the physical layer. Its primary responsibility is to provide reliable, efficient mechanism for the exchange of TLPs between two directly connected components on the link. Services provided by the data link layer include data exchange, initialization, error detection and correction, and retry services.

Data Link Layer Packets (DLLPs) are generated and consumed by the data link layer. DLLPs are the mechanism used to transfer link management information between data link layers of the two directly connected components on the link, including TLP acknowledgement, power management, and flow control.

### 10.2.3 Physical Layer

The physical layer of the PCIe provides a handshake mechanism between the data link layer and the high-speed signaling used for Link data interchange. This layer is divided into the logical and electrical functional subblocks. Both subblocks have dedicated transmit and receive units that allow for point-to-point communication between the host and CYW4356 device. The transmit section prepares outgoing information passed from the data link layer for transmission, and the receiver section identifies and prepares received information before passing it to the data link layer. This process involves link initialization, configuration, scrambler, and data conversion into a specific format.

### 10.2.4 Logical Subblock

The logical sub block primary functions are to prepare outgoing data from the data link layer for transmission and identify received data before passing it to the data link layer.

### 10.2.5 Scrambler/Descrambler

This PCIe PHY component generates pseudo-random sequence for scrambling of data bytes and the idle sequence. On the transmit side, scrambling is applied to characters prior to the 8b/10b encoding. On the receive side, descrambling is applied to characters after 8b/10b decoding. Scrambling may be disabled in polling and recovery for testing and debugging purposes.

### 10.2.6 8B/10B Encoder/Decoder

The PCIe core on the CYW4356 uses an 8b/10b encoder/decoder scheme to provide DC balancing, synchronizing clock and data recovery, and error detection. The transmission code is specified in the ANSI X3.230-1994, clause 11 and in IEEE 802.3z, 36.2.4.

Using this scheme, 8-bit data characters are treated as 3 bits and 5 bits mapped onto a 4-bit code group and a 6-bit code group, respectively. The control bit in conjunction with the data character is used to identify when to encode one of the twelve Special Symbols included in the 8b/10b transmission code. These code groups are concatenated to form a 10-bit symbol, which is then transmitted serially. Special Symbols are used for link management, frame TLPs, and DLLPs, allowing these packets to be quickly identified and easily distinguished.

### 10.2.7 Elastic FIFO

An elastic FIFO is implemented in the receiver side to compensate for the differences between the transmit clock domain and the receive clock domain, with worst case clock frequency specified at 600 ppm tolerance. As a result, the transmit and receive clocks can shift one clock every 1666 clocks. In addition, the FIFO adaptively adjusts the elastic level based on the relative frequency difference of the write and read clock. This technique reduces the elastic FIFO size and the average receiver latency by half.

### 10.2.8 Electrical Subblock

The high-speed signals utilize the Common Mode Logic (CML) signaling interface with on-chip termination and de-emphasis for best-in-class signal integrity. A de-emphasis technique is employed to reduce the effects of Intersymbol Interference (ISI) due to the interconnect by optimizing voltage and timing margins for worst case channel loss. This results in a maximally open "eye" at the detection point, thereby allowing the receiver to receive data with acceptable Bit-Error Rate (BER).

To further minimize ISI, multiple bits of the same polarity that are output in succession are de-emphasized. Subsequent same bits are reduced by a factor of 3.5 dB in power. This amount is specified by PCIe to allow for maximum interoperability while minimizing the complexity of controlling the de-emphasis values. The high-speed interface requires AC coupling on the transmit side to eliminate the DC common mode voltage from the receiver. The range of AC capacitance allowed is 75 nF to 200 nF.

### 10.2.9 Configuration Space

The PCIe function in the CYW4356 implements the configuration space as defined in the *PCI Express Base Specification v3.0*.

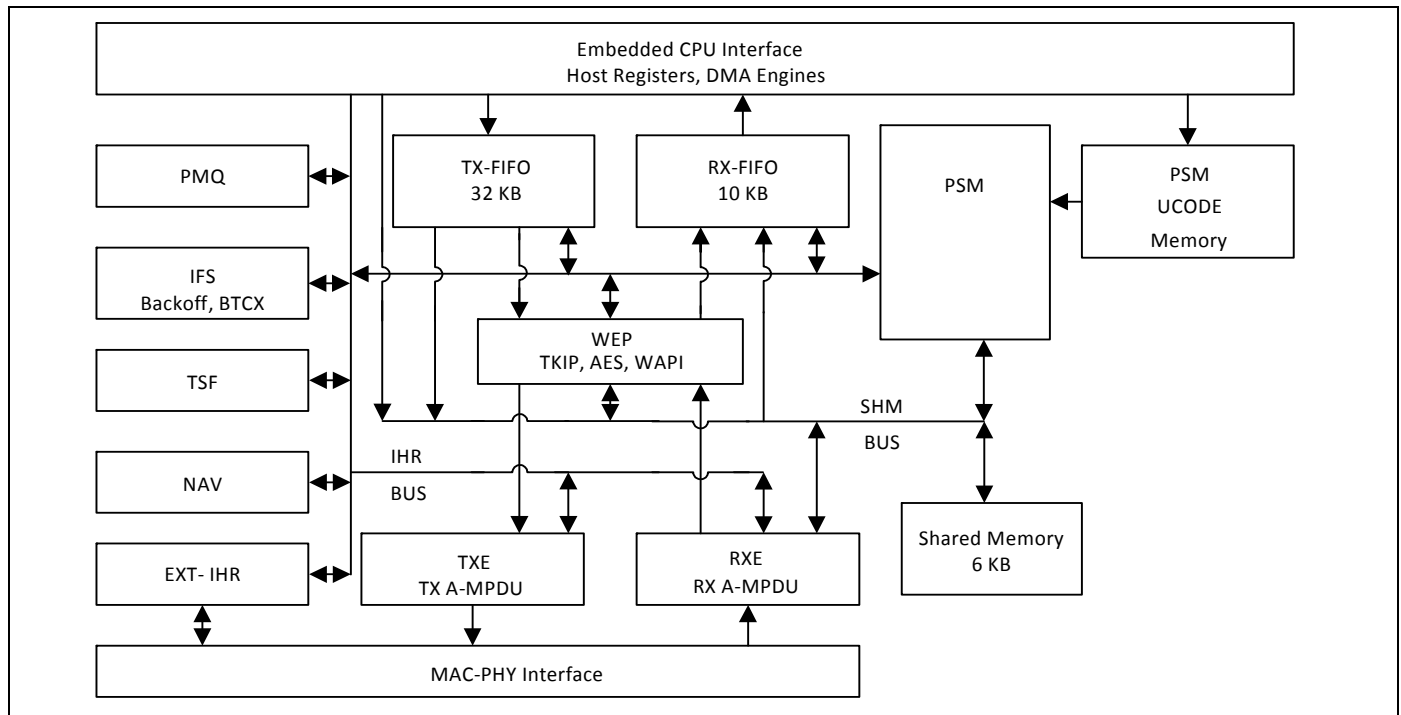
## 11. Wireless LAN MAC and PHY

### 11.1 IEEE 802.11ac Draft MAC

The CYW4356 WLAN MAC is designed to support high-throughput operation with low-power consumption. It does so without compromising the Bluetooth coexistence policies, thereby enabling optimal performance over both networks. In addition, several power saving modes have been implemented that allow the MAC to consume very little power while maintaining network-wide timing synchronization. The architecture diagram of the MAC is shown in Figure 32.

The following sections provide an overview of the important modules in the MAC.

Figure 32. WLAN MAC Architecture



The CYW4356 WLAN media access controller (MAC) supports features specified in the IEEE 802.11 base standard, and amended by IEEE 802.11n. The key MAC features include:

- Enhanced MAC for supporting IEEE 802.11ac Draft features
- Transmission and reception of aggregated MPDUs (A-MPDU) for high throughput (HT)
- Support for power management schemes, including WMM power-save, power-save multi-poll (PSMP) and multiphase PSMP operation
- Support for immediate ACK and Block-ACK policies
- Interframe space timing support, including RIFS
- Support for RTS/CTS and CTS-to-self frame sequences for protecting frame exchanges
- Back-off counters in hardware for supporting multiple priorities as specified in the WMM specification
- Timing synchronization function (TSF), network allocation vector (NAV) maintenance, and target beacon transmission time (TBTT) generation in hardware
- Hardware offload for AES-CCMP, legacy WPA TKIP, legacy WEP ciphers, WAPI, and support for key management
- Support for coexistence with Bluetooth and other external radios
- Programmable independent basic service set (IBSS) or infrastructure basic service set functionality
- Statistics counters for MIB support

## **PSM**

The programmable state machine (PSM) is a micro-coded engine, which provides most of the low-level control to the hardware, to implement the IEEE 802.11 specification. It is a microcontroller that is highly optimized for flow control operations, which are predominant in implementations of communication protocols. The instruction set and fundamental operations are simple and general, which allows algorithms to be optimized until very late in the design process. It also allows for changes to the algorithms to track evolving IEEE 802.11 specifications.

The PSM fetches instructions from the microcode memory. It uses the shared memory to obtain operands for instructions, as a data store, and to exchange data between both the host and the MAC data pipeline (via the SHM bus). The PSM also uses a scratchpad memory (similar to a register bank) to store frequently accessed and temporary variables.

The PSM exercises fine-grained control over the hardware engines, by programming internal hardware registers (IHR). These IHRs are co-located with the hardware functions they control, and are accessed by the PSM via the IHR bus.

The PSM fetches instructions from the microcode memory using an address determined by the program counter, instruction literal, or a program stack. For ALU operations the operands are obtained from shared memory, scratchpad, IHRs, or instruction literals, and the results are written into the shared memory, scratchpad, or IHRs.

There are two basic branch instructions: conditional branches and ALU based branches. To better support the many decision points in the IEEE 802.11 algorithms, branches can depend on either a readily available signals from the hardware modules (branch condition signals are available to the PSM without polling the IHRs), or on the results of ALU operations.

## **WEP**

The wired equivalent privacy (WEP) engine encapsulates all the hardware accelerators to perform the encryption and decryption, and MIC computation and verification. The accelerators implement the following cipher algorithms: legacy WEP, WPA TKIP, WPA2 AES-CCMP.

The PSM determines, based on the frame type and association information, the appropriate cipher algorithm to be used. It supplies the keys to the hardware engines from an on-chip key table. The WEP interfaces with the TXE to encrypt and compute the MIC on transmit frames, and the RXE to decrypt and verify the MIC on receive frames.

## **TXE**

The transmit engine (TXE) constitutes the transmit data path of the MAC. It coordinates the DMA engines to store the transmit frames in the TXFIFO. It interfaces with WEP module to encrypt frames, and transfers the frames across the MAC-PHY interface at the appropriate time determined by the channel access mechanisms.

The data received from the DMA engines are stored in transmit FIFOs. The MAC supports multiple logical queues to support traffic streams that have different QoS priority requirements. The PSM uses the channel access information from the IFS module to schedule a queue from which the next frame is transmitted. Once the frame is scheduled, the TXE hardware transmits the frame based on a precise timing trigger received from the IFS module.

The TXE module also contains the hardware that allows the rapid assembly of MPDUs into an A-MPDU for transmission. The hardware module aggregates the encrypted MPDUs by adding appropriate headers and pad delimiters as needed.

## **RXE**

The receive engine (RXE) constitutes the receive data path of the MAC. It interfaces with the DMA engine to drain the received frames from the RXFIFO. It transfers bytes across the MAC-PHY interface and interfaces with the WEP module to decrypt frames. The decrypted data is stored in the RXFIFO.

The RXE module contains programmable filters that are programmed by the PSM to accept or filter frames based on several criteria such as receiver address, BSSID, and certain frame types.

The RXE module also contains the hardware required to detect A-MPDUs, parse the headers of the containers, and disaggregate them into component MPDUS.

## **IFS**

The IFS module contains the timers required to determine interframe space timing including RIFS timing. It also contains multiple backoff engines required to support prioritized access to the medium as specified by WMM.

The interframe spacing timers are triggered by the cessation of channel activity on the medium, as indicated by the PHY. These timers provide precise timing to the TXE to begin frame transmission. The TXE uses this information to send response frames or perform transmit frame-bursting (RIFS or SIFS separated, as within a TXOP).

The backoff engines (for each access category) monitor channel activity, in each slot duration, to determine whether to continue or pause the backoff counters. When the backoff counters reach 0, the TXE gets notified, so that it may commence frame transmission. In the event of multiple backoff counters decrementing to 0 at the same time, the hardware resolves the conflict based on policies provided by the PSM.

The IFS module also incorporates hardware that allows the MAC to enter a low-power state when operating under the IEEE power save mode. In this mode, the MAC is in a suspended state with its clock turned off. A sleep timer, whose count value is initialized by the PSM, runs on a slow clock and determines the duration over which the MAC remains in this suspended state. Once the timer expires the MAC is restored to its functional state. The PSM updates the TSF timer based on the sleep duration ensuring that the TSF is synchronized to the network.

The IFS module also contains the PTA hardware that assists the PSM in Bluetooth coexistence functions.

## **TSF**

The timing synchronization function (TSF) module maintains the TSF timer of the MAC. It also maintains the target beacon transmission time (TBTT). The TSF timer hardware, under the control of the PSM, is capable of adopting timestamps received from beacon and probe response frames in order to maintain synchronization with the network.

The TSF module also generates trigger signals for events that are specified as offsets from the TSF timer, such as uplink and downlink transmission times used in PSMP.

## **NAV**

The network allocation vector (NAV) timer module is responsible for maintaining the NAV information conveyed through the duration field of MAC frames. This ensures that the MAC complies with the protection mechanisms specified in the standard.

The hardware, under the control of the PSM, maintains the NAV timer and updates the timer appropriately based on received frames. This timing information is provided to the IFS module, which uses it as a virtual carrier-sense indication.

## **MAC-PHY Interface**

The MAC-PHY interface consists of a data path interface to exchange RX/TX data from/to the PHY. In addition, there is an programming interface, which can be controlled either by the host or the PSM to configure and control the PHY.

### **11.2 IEEE 802.11ac Draft PHY**

The CYW4356 WLAN Digital PHY is designed to comply with IEEE 802.11ac Draft and IEEE 802.11a/b/g/n dual-stream specifications to provide wireless LAN connectivity supporting data rates from 1 Mbps to 866.7 Mbps for low-power, high-performance handheld applications.

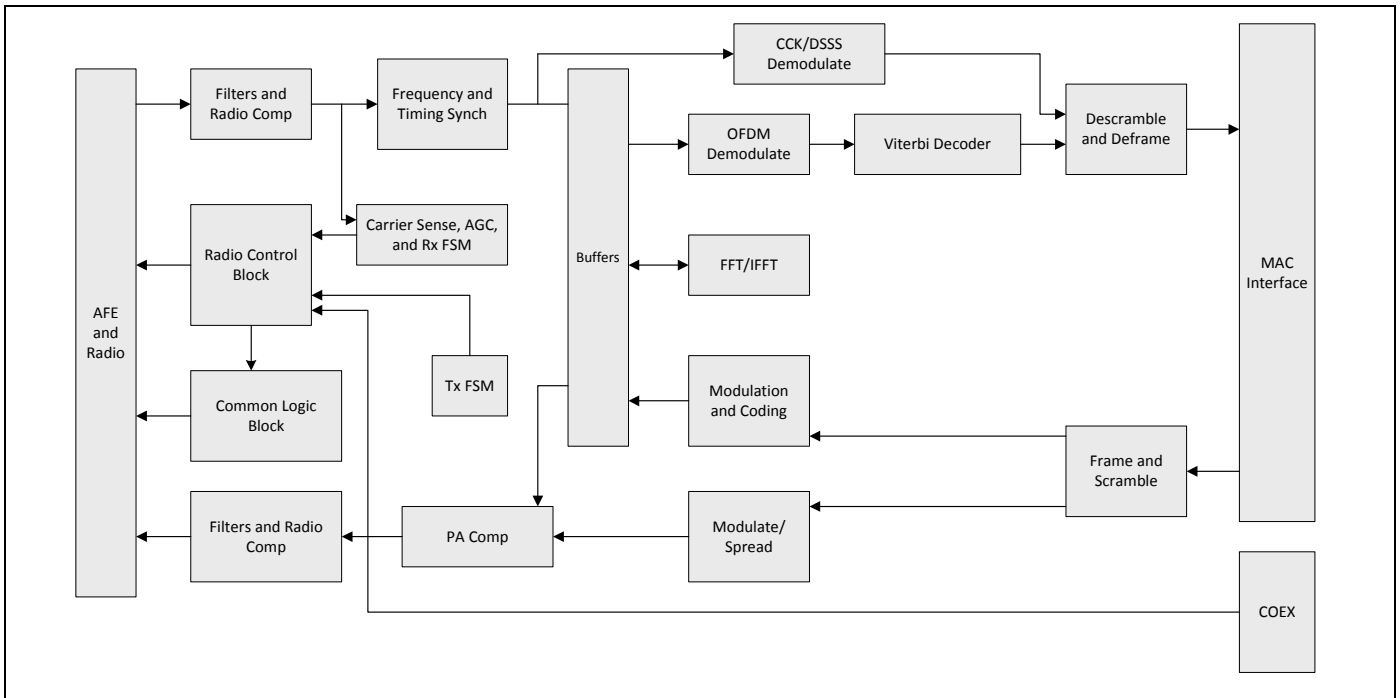
The PHY has been designed to work in the presence of interference, radio nonlinearity, and various other impairments. It incorporates optimized implementations of the filters, FFT and Viterbi decoder algorithms. Efficient algorithms have been designed to achieve maximum throughput and reliability, including algorithms for carrier sense/rejection, frequency/phase/timing acquisition and tracking, channel estimation and tracking. The PHY receiver also contains a robust IEEE 802.11b demodulator. The PHY carrier sense has been tuned to provide high throughput for IEEE 802.11g/11b hybrid networks with Bluetooth coexistence. It has also been designed for sharing an antenna between WL and BT to support simultaneous RX-RX.

The key PHY features include:

- Programmable data rates from MCS0–15 in 20 MHz, 40 MHz, and 80 MHz channels, as specified in IEEE 802.11ac Draft
- Supports Optional Short GI and Green Field modes in TX and RX
- TX and RX LDPC for improved range and power efficiency
- Beamforming support
- All scrambling, encoding, forward error correction, and modulation in the transmit direction and inverse operations in the receive direction.
- Supports IEEE 802.11h/k for worldwide operation
- Advanced algorithms for low power, enhanced sensitivity, range, and reliability

- Algorithms to improve performance in presence of Bluetooth
- Closed loop transmit power control
- Digital RF chip calibration algorithms to handle CMOS RF chip non-idealities
- On-the-fly channel frequency and transmit power selection
- Supports per packet RX antenna diversity
- Available per-packet channel quality and signal strength measurements
- Designed to meet FCC and other worldwide regulatory requirements

**Figure 33. WLAN PHY Block Diagram**





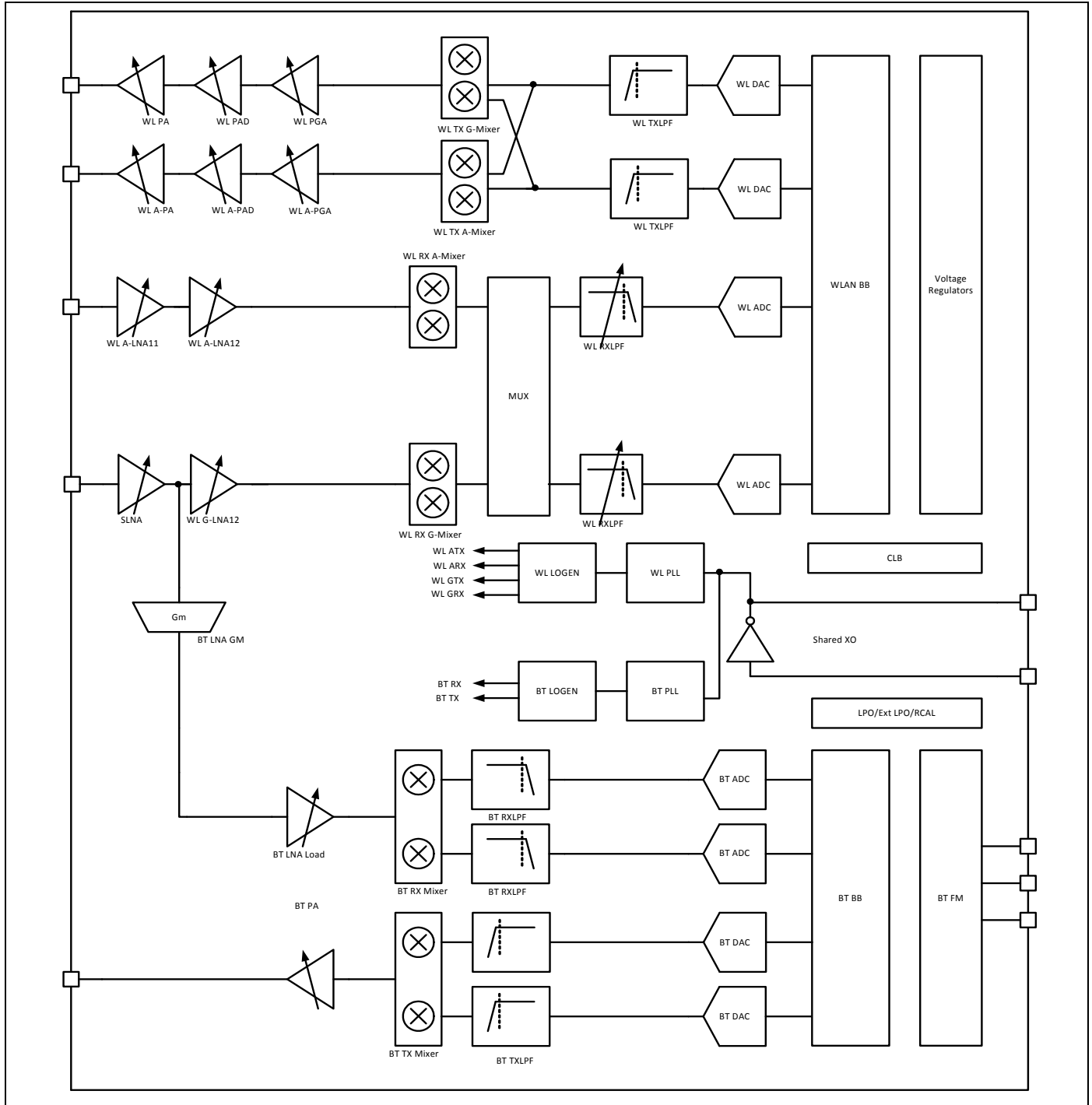
## 12. WLAN Radio Subsystem

The CYW4356 includes an integrated dual-band WLAN RF transceiver that has been optimized for use in 2.4 GHz and 5 GHz Wireless LAN systems. It has been designed to provide low-power, low-cost, and robust communications for applications operating in the globally available 2.4 GHz unlicensed ISM or 5 GHz U-NII bands. The transmit and receive sections include all on-chip filtering, mixing, and gain control functions.

Sixteen RF control signals are available (eight per core) to drive external RF switches and support optional external power amplifiers and low-noise amplifiers for each band. See the reference board schematics for further details.

A block diagram of the radio subsystem (core 0) is shown in [Figure 34](#). Core 1, is identical to Core 0 without the Bluetooth blocks. Note that integrated on-chip baluns (not shown) convert the fully differential transmit and receive paths to single-ended signal pins.

Figure 34. Radio Functional Block Diagram (Core 0)



### **12.1 Receiver Path**

The CYW4356 has a wide dynamic range, direct conversion receiver that employs high order on-chip channel filtering to ensure reliable operation in the noisy 2.4 GHz ISM band or the entire 5 GHz U-NII band. An on-chip low noise amplifier (LNA) in the 2.4 GHz path in core 0 is shared between the Bluetooth and WLAN receivers, whereas the 5 GHz receive path and the core 1 2.4 GHz receive path have dedicated on-chip LNAs. Control signals are available that can support the use of external LNAs for each band, which can increase the receive sensitivity by several dB.

### **12.2 Transmit Path**

Baseband data is modulated and upconverted to the 2.4 GHz ISM or 5 GHz U-NII bands, respectively. Linear on-chip power amplifiers are included, which are capable of delivering high output power while meeting IEEE 802.11ac and IEEE 802.11a/b/g/n specifications, and without the need for external PAs. When using the internal PAs, closed-loop output power control is completely integrated.

### **12.3 Calibration**

The CYW4356 features dynamic and automatic on-chip calibration to continually compensate for temperature and process variations across components. These calibration routines are performed periodically in the course of normal radio operation. Examples of some of the automatic calibration algorithms are baseband filter calibration for optimum transmit and receive performance, and LOFT calibration for carrier leakage reduction. In addition, I/Q Calibration, R Calibration, and VCO Calibration are performed on-chip. No per-board calibration is required in manufacturing test, which helps to minimize the test time and cost in large volume production.

### 13. Pin Information

#### 13.1 Ball Maps

Figure 35 shows the WLBGA ball map.

**Figure 35. CYW4356 A2 WLBGA BALL MAP; 12 × 18 Array; 192 Balls; Bottom View (Balls Facing Up)**

	12	11	10	9	8	7	6	5	4	3	2	1	
A	SR_PVSS	SR_VLX	WL_REG_ON	SDIO_CMD	SDIO_CLK	BT_GPIO_5	BT_GPIO_2	PCIE_REFCLKN	PCIE_REFCLKP	PCIE_TDN	PCIE_TDP		A
B	SR_VDDBATP5V	SR_VDDBATA5V	PMU_AVSS	SDIO_DATA_0	SDIO_DATA_2	VDDC	NC	PCIE_PLL_AVSS	PCIE_RXTX_AVSS	PCIE_PLL_AVDD1P2	PCIE_RXTX_AVDD1P2	PCIE_RDN	B
C	LDO_VDD1P5	VOUT_CLDO	VSSC	SDIO_DATA_1	SDIO_DATA_3	NC	NC	PCIE_PME_L	PCIE_PERST_L	PCIE_TESTP	PCIE_TESTN	PCIE_RDP	C
D	VOUT_BTLD02P5	VOUT_LNLD0	BT_REG_ON	JTAG_SEL		BT_GPIO_3	VSSC	PCIE_CLKREQ_L	VDDC	VSSC			D
E	LDO_VDDBAT5V	VOUT_LDO3P3_B	VDDIO	VDDC	VDDIO_SD	GPIO_7	GPIO_9	BT_USB_DN	BT_VDDC		FM_AUDIOVDD1P2	FM_AOUT1	E
F	VOUT_3P3	GPIO_2	GPIO_1	GPIO_5	GPIO_6	GPIO_8	LPO_IN	BT_USB_DP	CLK_REQ	FM_PLLVDD1P2	FM_AUDIOVSS	FM_AOUT2	F
G	VSSC	GPIO_0	VDDC	GPIO_3	VSSC	AVSS_BBPLL	BT_I2S_DO	BT_I2S_DI	VSSC	FM_PLLVSS	FM_VCOVSS	FM_LNAVCOVDD1P2	G
H	GPIO_10	VDDIO_RF		GPIO_4		AVDD_BBPLL		BT_UART_RXD	BT_PCM_OUT	BT_VDDC	FM_LNAVSS	FM_RFIN	H
J	VDDC	RF_SW_CTRL_9		RF_SW_CTRL_12	VDDC		BT_I2S_CLK	BT_UART_TXD	BT_PCM_IN	BT_HOST_WAKE	BT_VCOVSS	BT_VCOVDD1P2	J
K	RF_SW_CTRL_8		RF_SW_CTRL_13			BT_VDD0	BT_PCM_SYNC	BT_UART_RTS_N	BT_GPIO_4	BT_IFVDD1P2	BT_PLLVDD1P2	BT_LNAVDD1P2	K
L		VSSC	VDDC	RF_SW_CTRL_11	RF_SW_CTRL_15	VSSC	BT_I2S_WS	BT_UART_CTS_N	BT_DEV_WAKE	BT_PLLVSS	BT_PAVSS	BT_RF	L
M	RF_SW_CTRL_10		RF_SW_CTRL_14		RF_SW_CTRL_7	VDDC	BT_PCM_CLK	BT_VDDC	VSSC	BT_IFVSS		BT_PAVDD2P5	M
N	WRF_XTAL_OUT	WRF_XTAL_GND1P2	WRF_XTAL_VDD1P2		RF_SW_CTRL_1	RF_SW_CTRL_3		RF_SW_CTRL_4		WRF_RX2G_GND1P2_CORE0	WRF_LNA_2G_GND1P2_CORE0	WRF_RFIN_2G_CORE0	N
P	WRF_XTAL_IN	WRF_XTAL_VDD1P5		RF_SW_CTRL_2		RF_SW_CTRL_5		RF_SW_CTRL_6	WRF_AFE_GND1P2_CORE0	WRF_TX_GND1P2_CORE0	WRF_PA2G_VBAT_GND3P3_CORE0	WRF_RFOUT_2G_CORE0	P
R	WRF_BUCK_GND1P5_CORE1	WRF_BUCK_VDD1P5_CORE1		WRF_GPIO_OUT_CORE1	WRF_AFE_GND1P2_CORE1	RF_SW_CTRL_0	WRF_LOGEN_GND1P2	WRF_LOGENG_GND1P2	WRF_GPIO_OUT_CORE0	WRF_PADRV_VBAT_VDD3P3_CORE0	WRF_PA2G_VBAT_GND3P3_CORE0	WRF_PA2G_VBAT_VDD3P3_CORE0	R
T	WRF_RX5G_GND1P2_CORE1	WRF_TSSI_A_CORE1	WRF_PADRV_VBAT_GND3P3_CORE1	WRF_PADRV_VBAT_VDD3P3_CORE1	WRF_TX_GND1P2_CORE1	WRF_RX2G_GND1P2_CORE1	WRF_MMD_GND1P2	WRF_MMD_VDD1P2	WRF_PFD_VDD1P2	WRF_PADRV_VBAT_GND3P3_CORE0	WRF_PA5G_VBAT_GND3P3_CORE0	WRF_PA5G_VBAT_VDD3P3_CORE0	T
U	WRF_LNA_5G_GND1P2_CORE1	WRF_PA5G_VBAT_GND3P3_CORE1	WRF_PA5G_VBAT_GND3P3_CORE1	WRF_PA2G_VBAT_GND3P3_CORE1	WRF_PA2G_VBAT_GND3P3_CORE1	WRF_LNA_2G_GND1P2_CORE1	WRF_VCO_GND1P2	WRF_PFD_GND1P2	WRF_BUCK_VDD1P5_CORE0	WRF_TSSI_A_CORE0	WRF_PA5G_VBAT_GND3P3_CORE0	WRF_RFOUT_5G_CORE0	U
V	WRF_RFIN_5G_CORE1	WRF_RFOUT_5G_CORE1	WRF_PA5G_VBAT_VDD3P3_CORE1	WRF_PA2G_VBAT_VDD3P3_CORE1	WRF_RFOUT_2G_CORE1	WRF_RFIN_2G_CORE1	WRF_SYNTH_VBAT_VDD3P3	WRF_CP_GND1P2	WRF_BUCK_GND1P5_CORE0	WRF_RX5G_GND1P2_CORE0	WRF_LNA_5G_GND1P2_CORE0	WRF_RFIN_5G_CORE0	V
	12	11	10	9	8	7	6	5	4	3	2	1	

**13.2 Pin Lists**
**Table 19. Pin List by Pin Number (192-Pin WLBGA Package)**

WLBGA Ball#	Pin Name
A10	WL_REG_ON
A11	SR_VLX
A12	SR_PVSS
A2	PCIE_TDP0
A3	PCIE_TDN0
A4	PCIE_REFCLKP
A5	PCIE_REFCLKN
A6	BT_GPIO_2
A7	BT_GPIO_5
A8	SDIO_CLK
A9	SDIO_CMD
B1	PCIE_RDN0
B10	PMU_AVSS
B11	SR_VDDBATA5V
B12	SR_VDDBATP5V
B2	PCIE_RXTX_AVDD1P2
B3	PCIE_PLL_AVDD1P2
B4	PCIE_RXTX_AVSS
B5	PCIE_PLL_AVSS
B6	NC
B7	VDD/VDDC
B8	SDIO_DATA_2
B9	SDIO_DATA_0
C1	PCIE_RDP0
C10	VSSC/VSS
C11	VOUT_CLDO
C12	LDO_VDD1P5
C2	PCIE_TESTN
C3	PCIE_TESTP
C4	PCIE_PERST_L
C5	PCIE_PME_L
C6	NC
C7	NC
C8	SDIO_DATA_3
C9	SDIO_DATA_1
D10	BT_REG_ON
D11	VOUT_LNLDO
D12	VOUT_BTLDO2P5
D3	VSSC/VSS
D4	VDD/VDDC
D5	PCIE_CLKREQ_L

**Table 19. Pin List by Pin Number (192-Pin WLBGA Package)**

WLBGA Ball#	Pin Name
D6	VSSC/VSS
D7	BT_GPIO_3
D9	JTAG_SEL
E1	FM_AOUT1
E10	VDDIO
E11	VOUT_LDO3P3_B
E12	LDO_VDDBAT5V
E2	FM_AUDIOVDD1P2
E4	BT_VDDC
E5	BT_USB_DN
E6	GPIO_9
E7	GPIO_7
E8	VDDIO_SD
E9	VDD/VDDC
F1	FM_AOUT2
F10	GPIO_1
F11	GPIO_2
F12	VOUT_3P3
F2	FM_AUDIOVSS
F3	FM_PLLVDD1P2
F4	CLK_REQ
F5	BT_USB_DP
F6	LPO_IN
F7	GPIO_8
F8	GPIO_6
F9	GPIO_5
G1	FM_LNAVCOVDD1P2
G10	VDD/VDDC
G11	GPIO_0
G12	VSSC/VSS
G2	FM_VCOVSS
G3	FM_PLLVSS
G4	VSSC/VSS
G5	BT_I2S_DI
G6	BT_I2S_DO
G7	AVSS_BBPLL
G8	VSSC/VSS
G9	GPIO_3
H1	FM_RFIN
H11	VDDIO_RF
H12	GPIO_10

**Table 19. Pin List by Pin Number (192-Pin WLBGA Package)**

WLBGA Ball#	Pin Name
H2	FM_LNAVSS
H3	BT_VDDC
H4	BT_PCM_OUT
H5	BT_UART_RXD
H7	AVDD_BBPLL
H9	GPIO_4
J1	BT_VCOVDD1P2
J11	RF_SW_CTRL_9
J12	VDD/VDDC
J2	BT_VCOVSS
J3	BT_HOST_WAKE
J4	BT_PCM_IN
J5	BT_UART_TXD
J6	BT_I2S_CLK
J8	VDD/VDDC
J9	RF_SW_CTRL_12
K1	BT_LNAVDD1P2
K10	RF_SW_CTRL_13
K12	RF_SW_CTRL_8
K2	BT_PLLVDD1P2
K3	BT_IFVDD1P2
K4	BT_GPIO_4
K5	BT_UART_RTS_L
K6	BT_PCM_SYNC
K7	BT_VDDIO
L1	BT_RF
L10	VDD/VDDC
L11	VSSC/VSS
L2	BT_PAVSS
L3	BT_PLLVSS
L4	BT_DEV_WAKE
L5	BT_UART_CTS_L
L6	BT_I2S_WS
L7	VSSC/VSS
L8	RF_SW_CTRL_15
L9	RF_SW_CTRL_11
M1	BT_PAVDD2P5
M10	RF_SW_CTRL_14
M12	RF_SW_CTRL_10
M3	BT_IFVSS
M4	VSSC/VSS
M5	BT_VDDC

**Table 19. Pin List by Pin Number (192-Pin WLBGA Package)**

WLBGA Ball#	Pin Name
M6	BT_PCM_CLK
M7	VDD/VDDC
M8	RF_SW_CTRL_7
N1	WRF_RFIN_2G_CORE0
N10	WRF_XTAL_VDD1P2
N11	WRF_XTAL_GND1P2
N12	WRF_XTAL_OUT
N2	WRF_LNA_2G_GND1P2_CORE0
N3	WRF_RX2G_GND1P2_CORE0
N5	RF_SW_CTRL_4
N7	RF_SW_CTRL_3
N8	RF_SW_CTRL_1
P1	WRF_RFOUT_2G_CORE0
P11	WRF_XTAL_VDD1P5
P12	WRF_XTAL_IN
P2	WRF_PA2G_VBAT_GND3P3_CORE0
P3	WRF_TX_GND1P2_CORE0
P4	WRF_AFE_GND1P2_CORE0
P5	RF_SW_CTRL_6
P7	RF_SW_CTRL_5
P9	RF_SW_CTRL_2
R1	WRF_PA2G_VBAT_VDD3P3_CORE0
R11	WRF_BUCK_VDD1P5_CORE1
R12	WRF_BUCK_GND1P5_CORE1
R2	WRF_PA2G_VBAT_GND3P3_CORE0
R3	WRF_PADRV_VBAT_VDD3P3_CORE0
R4	WRF_GPIO_OUT_CORE0
R5	WRF_LOGENG_GND1P2
R6	WRF_LOGEN_GND1P2
R7	RF_SW_CTRL_0
R8	WRF_AFE_GND1P2_CORE1
R9	WRF_GPIO_OUT_CORE1
T1	WRF_PA5G_VBAT_VDD3P3_CORE0
T10	WRF_PADRV_VBAT_GND3P3_CORE1
T11	WRF_TSSI_A_CORE1
T12	WRF_RX5G_GND1P2_CORE1
T2	WRF_PA5G_VBAT_GND3P3_CORE0
T3	WRF_PADRV_VBAT_GND3P3_CORE0
T4	WRF_PFD_VDD1P2
T5	WRF_MMD_VDD1P2
T6	WRF_MMD_GND1P2
T7	WRF_RX2G_GND1P2_CORE1

**Table 19. Pin List by Pin Number (192-Pin WLBGA Package)**

WLBGA Ball#	Pin Name
T8	WRF_TX_GND1P2_CORE1
T9	WRF_PADRV_VBAT_VDD3P3_CORE1
U1	WRF_RFOUT_5G_CORE0
U10	WRF_PA5G_VBAT_GND3P3_CORE1
U11	WRF_PA5G_VBAT_GND3P3_CORE1
U12	WRF_LNA_5G_GND1P2_CORE1
U2	WRF_PA5G_VBAT_GND3P3_CORE0
U3	WRF_TSSI_A_CORE0
U4	WRF_BUCK_VDD1P5_CORE0
U5	WRF_PFD_GND1P2
U6	WRF_VCO_GND1P2
U7	WRF_LNA_2G_GND1P2_CORE1
U8	WRF_PA2G_VBAT_GND3P3_CORE1
U9	WRF_PA2G_VBAT_GND3P3_CORE1
V1	WRF_RFIN_5G_CORE0
V10	WRF_PA5G_VBAT_VDD3P3_CORE1
V11	WRF_RFOUT_5G_CORE1
V12	WRF_RFIN_5G_CORE1
V2	WRF_LNA_5G_GND1P2_CORE0
V3	WRF_RX5G_GND1P2_CORE0
V4	WRF_BUCK_GND1P5_CORE0
V5	WRF_CP_GND1P2
V6	WRF_SYNTH_VBAT_VDD3P3
V7	WRF_RFIN_2G_CORE1
V8	WRF_RFOUT_2G_CORE1
V9	WRF_PA2G_VBAT_VDD3P3_CORE1

**Table 20. Pin List by Pin Name (192-Pin WLBGA Package)**

Pin Name	WLBGA Ball#
AVDD_BBPLL	H7
AVSS_BBPLL	G7
BT_DEV_WAKE	L4
BT_GPIO_2	A6
BT_GPIO_5	A7
BT_GPIO_3	D7
BT_GPIO_4	K4
BT_HOST_WAKE	J3
BT_I2S_CLK	J6
BT_I2S_DI	G5
BT_I2S_DO	G6
BT_I2S_WS	L6
BT_IFVDD1P2	K3
BT_IFVSS	M3
BT_LNAVDD1P2	K1
BT_PAVDD2P5	M1
BT_PAVSS	L2
BT_PCM_CLK	M6
BT_PCM_IN	J4
BT_PCM_OUT	H4
BT_PCM_SYNC	K6
BT_PLLVDD1P2	K2
BT_PLLVSS	L3
BT_REG_ON	D10
BT_RF	L1
BT_UART_CTS_L	L5
BT_UART_RTS_L	K5
BT_UART_RXD	H5
BT_UART_TXD	J5
BT_USB_DN	E5
BT_USB_DP	F5
BT_VCOVDD1P2	J1
BT_VCOVSS	J2
BT_VDDC	E4
BT_VDDC	H3
BT_VDDC	M5
BT_VDDIO	K7
CLK_REQ	F4
FM_AOUT1	E1
FM_AOUT2	F1
FM_AUDIOVDD1P2	E2

**Table 20. Pin List by Pin Name (192-Pin WLBGA Package)**

Pin Name	WLBGA Ball#
FM_AUDIOVSS	F2
FM_LNAVCOVDD1P2	G1
FM_LNAVSS	H2
FM_PLLVDD1P2	F3
FM_PLLVSS	G3
FM_RFIN	H1
FM_VCOVSS	G2
GPIO_0	G11
GPIO_1	F10
GPIO_10	H12
GPIO_2	F11
GPIO_3	G9
GPIO_4	H9
GPIO_5	F9
GPIO_6	F8
GPIO_7	E7
GPIO_8	F7
GPIO_9	E6
JTAG_SEL	D9
LDO_VDD1P5	C12
LDO_VDDBAT5V	E12
LPO_IN	F6
NC	B6
NC	C7
NC	C6
PCIE_PME_L	C5
PCIE_CLKREQ_L	D5
PCIE_PERST_L	C4
PCIE_PLL_AVDD1P2	B3
PCIE_PLL_AVSS	B5
PCIE_RDN0	B1
PCIE_RDP0	C1
PCIE_REFCLKN	A5
PCIE_REFCLKP	A4
PCIE_RXTX_AVDD1P2	B2
PCIE_RXTX_AVSS	B4
PCIE_TDN0	A3
PCIE_TDP0	A2
PCIE_TESTN	C2
PCIE_TESTP	C3
PMU_AVSS	B10



**Table 20. Pin List by Pin Name (192-Pin WLBGA Package)**

Pin Name	WLBGA Ball#
RF_SW_CTRL_0	R7
RF_SW_CTRL_1	N8
RF_SW_CTRL_10	M12
RF_SW_CTRL_11	L9
RF_SW_CTRL_12	J9
RF_SW_CTRL_13	K10
RF_SW_CTRL_14	M10
RF_SW_CTRL_15	L8
RF_SW_CTRL_2	P9
RF_SW_CTRL_3	N7
RF_SW_CTRL_4	N5
RF_SW_CTRL_5	P7
RF_SW_CTRL_6	P5
RF_SW_CTRL_7	M8
RF_SW_CTRL_8	K12
RF_SW_CTRL_9	J11
SDIO_CLK	A8
SDIO_CMD	A9
SDIO_DATA_0	B9
SDIO_DATA_1	C9
SDIO_DATA_2	B8
SDIO_DATA_3	C8
SR_PVSS	A12
SR_VDDBATA5V	B11
SR_VDDBATP5V	B12
SR_VLX	A11
VDD/VDDC	B7
VDD/VDDC	D4
VDD/VDDC	E9
VDD/VDDC	G10
VDD/VDDC	J12
VDD/VDDC	J8
VDD/VDDC	L10
VDD/VDDC	M7
VDDIO	E10
VDDIO_RF	H11
VDDIO_SD	E8
VOUT_3P3	F12
VOUT_BTLDO2P5	D12
VOUT_CLDO	C11
VOUT_LDO3P3_B	E11
VOUT_LNLDO	D11

**Table 20. Pin List by Pin Name (192-Pin WLBGA Package)**

Pin Name	WLBGA Ball#
VSSC/VSS	C10
VSSC/VSS	D3
VSSC/VSS	D6
VSSC/VSS	G12
VSSC/VSS	G4
VSSC/VSS	G8
VSSC/VSS	L11
VSSC/VSS	L7
VSSC/VSS	M4
WL_REG_ON	A10
WRF_AFE_GND1P2_CORE0	P4
WRF_AFE_GND1P2_CORE1	R8
WRF_BUCK_GND1P5_CORE0	V4
WRF_BUCK_GND1P5_CORE1	R12
WRF_BUCK_VDD1P5_CORE0	U4
WRF_BUCK_VDD1P5_CORE1	R11
WRF_CP_GND1P2	V5
WRF_GPIO_OUT_CORE0	R4
WRF_GPIO_OUT_CORE1	R9
WRF_LNA_2G_GND1P2_CORE0	N2
WRF_LNA_2G_GND1P2_CORE1	U7
WRF_LNA_5G_GND1P2_CORE0	V2
WRF_LNA_5G_GND1P2_CORE1	U12
WRF_LOGEN_GND1P2	R6
WRF_LOGENG_GND1P2	R5
WRF_MMD_GND1P2	T6
WRF_MMD_VDD1P2	T5
WRF_PA2G_VBAT_GND3P3_CORE0	P2
WRF_PA2G_VBAT_GND3P3_CORE0	R2
WRF_PA2G_VBAT_GND3P3_CORE1	U8
WRF_PA2G_VBAT_GND3P3_CORE1	U9
WRF_PA2G_VBAT_VDD3P3_CORE0	R1
WRF_PA2G_VBAT_VDD3P3_CORE1	V9
WRF_PA5G_VBAT_GND3P3_CORE0	T2
WRF_PA5G_VBAT_GND3P3_CORE0	U2
WRF_PA5G_VBAT_GND3P3_CORE1	U10
WRF_PA5G_VBAT_GND3P3_CORE1	U11
WRF_PA5G_VBAT_VDD3P3_CORE0	T1
WRF_PA5G_VBAT_VDD3P3_CORE1	V10
WRF_PADRV_VBAT_GND3P3_CORE0	T3
WRF_PADRV_VBAT_GND3P3_CORE1	T10

**Table 20. Pin List by Pin Name (192-Pin WLBGA Package)**

Pin Name	WLBGA Ball#
WRF_PADRV_VBAT_VDD3P3_CORE0	R3
WRF_PADRV_VBAT_VDD3P3_CORE1	T9
WRF_PFD_GND1P2	U5
WRF_PFD_VDD1P2	T4
WRF_RFIN_2G_CORE0	N1
WRF_RFIN_2G_CORE1	V7
WRF_RFIN_5G_CORE0	V1
WRF_RFIN_5G_CORE1	V12
WRF_RFOUT_2G_CORE0	P1
WRF_RFOUT_2G_CORE1	V8
WRF_RFOUT_5G_CORE0	U1
WRF_RFOUT_5G_CORE1	V11
WRF_RX2G_GND1P2_CORE0	N3
WRF_RX2G_GND1P2_CORE1	T7
WRF_RX5G_GND1P2_CORE0	V3
WRF_RX5G_GND1P2_CORE1	T12
WRF_SYNTH_VBAT_VDD3P3	V6
WRF_TSSI_A_CORE0	U3
WRF_TSSI_A_CORE1	T11
WRF_TX_GND1P2_CORE0	P3
WRF_TX_GND1P2_CORE1	T8
WRF_VCO_GND1P2	U6
WRF_XTAL_GND1P2	N11
WRF_XTAL_IN	P12
WRF_XTAL_OUT	N12
WRF_XTAL_VDD1P2	N10
WRF_XTAL_VDD1P5	P11

**Table 21. 395-Bump WLCSP Coordinates**

No.	Net Name	Coordinates (0,0 center of die)			
		Bump Side		Top Side	
		X	Y	X	Y
1	PCIE_RXTX_AVSS	2300.51	3659.87	-2300.51	3659.87
2	PCIE_PLL_AVSS	1966.81	3659.87	-1966.81	3659.87
3	PCIE_REFCLKP	1966.81	3434.87	-1966.81	3434.87
4	PCIE_REFCLKN	1800.31	3547.37	-1800.31	3547.37
5	PCIE_TDN0	2134.01	3547.37	-2134.01	3547.37
6	PCIE_TDP0	2134.01	3322.37	-2134.01	3322.37
7	PCIE_RXTX_AVDD1P2	2134.01	3068.53	-2134.01	3068.53
8	PCIE_RDP0	2300.51	3209.87	-2300.51	3209.87
9	PCIE_RDN0	2300.51	3434.87	-2300.51	3434.87
10	PCIE_PLL_AVSS	1966.81	3209.87	-1966.81	3209.87
11	PCIE_PLL_AVDD1P2	1800.31	3322.37	-1800.31	3322.37
12	NC	508.44	3481.00	-508.44	3481.00
13	NC	768.62	3062.57	-768.62	3062.57
14	NC	508.44	3281.00	-508.44	3281.00
15	NC	1177.22	3062.57	-1177.22	3062.57
16	NC	972.92	3062.57	-972.92	3062.57
17	NC	553.11	3681.00	-553.11	3681.00
18	NC	753.11	3681.00	-753.11	3681.00
19	NC	773.17	3481.00	-773.17	3481.00
20	NC	773.17	3281.00	-773.17	3281.00
21	NC	974.72	3481.00	-974.72	3481.00
22	NC	974.72	3281.00	-974.72	3281.00
23	NC	982.37	3681.00	-982.37	3681.00
24	NC	1176.88	3281.00	-1176.88	3281.00
25	NC	1176.88	3481.00	-1176.88	3481.00
26	NC	1186.67	3681.00	-1186.67	3681.00
27	NC	526.91	3062.57	-526.91	3062.57
28	NC	1177.22	2860.07	-1177.22	2860.07
29	NC	768.62	2860.07	-768.62	2860.07
30	GND	1601.79	3595.19	-1601.79	3595.19
31	NC	1601.79	2792.39	-1601.79	2792.39
32	GND	1401.09	3394.49	-1401.09	3394.49
33	NC	1601.79	3394.49	-1601.79	3394.49
34	GND	1601.79	2993.09	-1601.79	2993.09
35	NC	1601.79	3193.79	-1601.79	3193.79
36	GND	1401.09	2792.39	-1401.09	2792.39
37	GND	1401.09	3595.19	-1401.09	3595.19
38	NC	1401.09	2993.09	-1401.09	2993.09
39	GND	1401.09	3193.79	-1401.09	3193.79

**Table 21. 395-Bump WLCSP Coordinates (Cont.)**

No.	Net Name	Coordinates (0,0 center of die)			
		Bump Side		Top Side	
		X	Y	X	Y
40	BT_PAVSS	2217.95	-736.50	-2217.95	-736.50
41	BT_AGPIO	2017.95	-1298.03	-2017.95	-1298.03
42	BT_IFVDD1P2	1768.91	-1298.03	-1768.91	-1298.03
43	BT_IFVSS	1568.92	-1298.03	-1568.92	-1298.03
44	BT_LNAVDD1P2	2228.18	-392.72	-2228.18	-392.72
45	BT_LNAVSS	1843.60	-524.82	-1843.60	-524.82
46	BT_PAVDD2P5	2176.03	-1164.53	-2176.03	-1164.53
47	BT_PLLVDD1P2	1768.91	-223.55	-1768.91	-223.55
48	BT_PLLVSS	1568.92	-223.55	-1568.92	-223.55
49	BT_RF	2252.39	-936.50	-2252.39	-936.50
50	BT_VCOVDD1P2	2227.01	-189.65	-2227.01	-189.65
51	BT_VCOVSS	1967.62	-45.40	-1967.62	-45.40
52	FM_AUDIOVDD1P2	2044.00	931.81	-2044.00	931.81
53	FM_AUDIOAVSS	2044.00	1143.58	-2044.00	1143.58
54	FM_AOUT1	2244.00	1143.58	-2244.00	1143.58
55	FM_AOUT2	2244.00	931.81	-2244.00	931.81
56	FM_IFVDD1P2	1614.95	371.79	-1614.95	371.79
57	FM_IFVSS	1614.95	171.80	-1614.95	171.80
58	FM_PLLVSS	1793.21	871.61	-1793.21	871.61
59	FM_PLLVDD1P2	1686.40	695.87	-1686.40	695.87
60	FM_RFAUX	2273.40	68.08	-2273.40	68.08
61	FM_RFIN	2260.02	313.69	-2260.02	313.69
62	FM_LNAVDD1P2	2060.02	354.59	-2060.02	354.59
63	FM_LNAVSS	2060.02	154.59	-2060.02	154.59
64	FM_VCOVDD1P2	2273.40	731.81	-2273.40	731.81
65	FM_VCOVSS	2273.40	531.81	-2273.40	531.81
66	RF_SW_CTRL_0	-2202.33	-1494.00	2202.33	-1494.00
67	VDDC	-661.10	-1355.99	661.10	-1355.99
68	VSSC	740.99	2052.00	-740.99	2052.00
69	VSSC	-616.50	-408.01	616.50	-408.01
70	VSSC	-459.00	-198.00	459.00	-198.00
71	VSSC	-546.71	-1008.00	546.71	-1008.00
72	VSSC	-546.71	-708.00	546.71	-708.00
73	VSSC	-459.00	252.00	459.00	252.00
74	VDDC	-661.10	-21.01	661.10	-21.01
75	VSSC	740.99	2352.00	-740.99	2352.00
76	VDDIO_SD	-405.00	2299.50	405.00	2299.50
77	SDIO_DATA_1	-337.05	2531.57	337.05	2531.57
78	SDIO_CLK	-337.05	2731.57	337.05	2731.57
79	SDIO_DATA_3	-337.05	2931.58	337.05	2931.58

**Table 21. 395-Bump WLCSP Coordinates (Cont.)**

No.	Net Name	Coordinates (0,0 center of die)			
		Bump Side		Top Side	
		X	Y	X	Y
80	SDIO_DATA_2	-337.05	3131.59	337.05	3131.59
81	SDIO_CMD	-337.05	3331.59	337.05	3331.59
82	SDIO_DATA_0	-337.05	3531.60	337.05	3531.60
83	VSSC	-316.50	-408.01	316.50	-408.01
84	VSSC	-266.51	-1008.00	266.51	-1008.00
85	VSSC	-266.51	-708.00	266.51	-708.00
86	RF_SW_CTRL_4	-2072.12	-1125.00	2072.12	-1125.00
87	VDDC	-261.11	-21.01	261.11	-21.01
88	VSSC	-259.00	1651.99	259.00	1651.99
89	VSSC	-159.00	252.00	159.00	252.00
90	VSSC	-159.00	552.00	159.00	552.00
91	VSSC	-159.00	851.99	159.00	851.99
92	VSSC	-159.00	1151.99	159.00	1151.99
93	VSSC	-159.00	1451.99	159.00	1451.99
94	VSSC	-159.00	2052.00	159.00	2052.00
95	VSSC	-459.00	552.00	459.00	552.00
96	GND	-67.05	2286.36	67.05	2286.36
97	GND	-67.05	2486.57	67.05	2486.57
98	VDDC_98	-67.05	2686.57	67.05	2686.57
99	NC	-67.05	2886.58	67.05	2886.58
100	NC	-67.05	3086.59	67.05	3086.59
101	NC	-67.05	3286.59	67.05	3286.59
102	VDDC_102	-67.05	3486.60	67.05	3486.60
103	VDDC	-61.11	-1220.99	61.11	-1220.99
104	VSSC	-61.11	-1008.00	61.11	-1008.00
105	VSSC	-61.11	-708.00	61.11	-708.00
106	VSSC	-61.11	-408.01	61.11	-408.01
107	VDDC	-61.11	-21.01	61.11	-21.01
108	VDDC	-61.11	1843.97	61.11	1843.97
109	VDDC	138.89	-1220.99	-138.89	-1220.99
110	VDDC	138.89	-1021.00	-138.89	-1021.00
111	VDDC	138.89	-821.00	-138.89	-821.00
112	VDDC	-261.11	-1220.99	261.11	-1220.99
113	VDDC	138.89	-421.00	-138.89	-421.00
114	VDDC	138.89	-221.00	-138.89	-221.00
115	VDDC	138.89	-21.01	-138.89	-21.01
116	VSSC	140.99	252.00	-140.99	252.00
117	VSSC	140.99	552.00	-140.99	552.00
118	VSSC	140.99	851.99	-140.99	851.99
119	VSSC	140.99	1151.99	-140.99	1151.99

**Table 21. 395-Bump WLCSP Coordinates (Cont.)**

No.	Net Name	Coordinates (0,0 center of die)			
		Bump Side		Top Side	
		X	Y	X	Y
120	VSSC	140.99	1451.99	-140.99	1451.99
121	VSSC	140.99	1651.99	-140.99	1651.99
122	VSSC	140.99	2052.00	-140.99	2052.00
123	PACKAGEOPTION_4	140.99	2352.00	-140.99	2352.00
124	BT_VSSC	768.37	-1186.86	-768.37	-1186.86
125	BT_VSSC	816.40	21.84	-816.40	21.84
126	BT_VSSC	599.69	-715.49	-599.69	-715.49
127	VDDC	338.89	443.99	-338.89	443.99
128	VDDC	338.89	643.99	-338.89	643.99
129	VDDC	338.89	1843.97	-338.89	1843.97
130	VSSC	-459.00	851.99	459.00	851.99
131	PACKAGEOPTION_2	440.99	2352.00	-440.99	2352.00
132	PACKAGEOPTION_3	440.99	2592.00	-440.99	2592.00
133	BT_VSSC	468.37	-1186.86	-468.37	-1186.86
134	VDDC	538.88	643.99	-538.88	643.99
135	VDDC	538.88	843.98	-538.88	843.98
136	VDDC	538.88	1043.98	-538.88	1043.98
137	VDDC	538.88	1243.98	-538.88	1243.98
138	VDDC	538.88	1443.98	-538.88	1443.98
139	VDDC	538.88	1643.98	-538.88	1643.98
140	VDDC	538.88	1843.97	-538.88	1843.97
141	BT_VDDC_ISO_1	601.19	-970.04	-601.19	-970.04
142	BT_VDDC_ISO_2	620.91	-500.07	-620.91	-500.07
143	AVDD_BBPLL	655.50	168.14	-655.50	168.14
144	AVSS_BBPLL	655.50	437.48	-655.50	437.48
145	BT_VDDC	1480.37	555.67	-1480.37	555.67
146	PACKAGEOPTION_1	740.99	2592.00	-740.99	2592.00
147	BT_VDDC	1480.37	780.66	-1480.37	780.66
148	BT_VDDIO	830.29	-445.06	-830.29	-445.06
149	BT_VDDIO	840.29	-724.53	-840.29	-724.53
150	BT_VDDIO	865.28	-245.06	-865.28	-245.06
151	BT_VDDIO	915.28	-973.39	-915.28	-973.39
152	PACKAGEOPTION_0	1040.99	2592.00	-1040.99	2592.00
153	BT_GPIO_5	1048.37	420.67	-1048.37	420.67
154	BT_GPIO_3	1048.37	620.67	-1048.37	620.67
155	BT_GPIO_2	1048.37	820.67	-1048.37	820.67
156	BT_I2S_DI	1444.06	1426.01	-1444.06	1426.01
157	BT_UART_TXD	1444.06	1643.00	-1444.06	1643.00
158	BT_I2S_WS	1143.51	1940.00	-1143.51	1940.00
159	LPO_IN	1143.51	2237.00	-1143.51	2237.00

**Table 21. 395-Bump WLCSP Coordinates (Cont.)**

No.	Net Name	Coordinates (0,0 center of die)			
		Bump Side		Top Side	
		X	Y	X	Y
160	OTP_VDD33	1348.51	2444.00	-1348.51	2444.00
161	BT_CLK_REQ	1644.06	1426.01	-1644.06	1426.01
162	BT_UART_RXD	1644.06	1643.00	-1644.06	1643.00
163	BT_PCM_SYNC	1343.51	1940.00	-1343.51	1940.00
164	BT_USB_DN	1343.51	2237.00	-1343.51	2237.00
165	PCIE_PME_L	1548.50	2444.00	-1548.50	2444.00
166	BT_TM1	1844.06	1346.00	-1844.06	1346.00
167	BT_I2S_CLK	1844.06	1643.00	-1844.06	1643.00
168	BT_GPIO_4	1543.51	1940.00	-1543.51	1940.00
169	BT_USB_DP	1543.51	2237.00	-1543.51	2237.00
170	BT_HOST_WAKE	2044.05	1346.00	-2044.05	1346.00
171	BT_I2S_DO	2044.05	1643.00	-2044.05	1643.00
172	BT_UART_CTS_N	1743.51	1940.00	-1743.51	1940.00
173	BT_PCM_IN	1743.51	2237.00	-1743.51	2237.00
174	PCIE_CLKREQ_L	1858.50	2534.00	-1858.50	2534.00
175	RF_SW_CTRL_1	-2002.32	-1494.00	2002.32	-1494.00
176	BT_DEV_WAKE	2244.05	1346.00	-2244.05	1346.00
177	BT_PCM_OUT	2244.05	1643.00	-2244.05	1643.00
178	BT_UART_RTS_N	1943.51	1940.00	-1943.51	1940.00
179	BT_PCM_CLK	1943.51	2237.00	-1943.51	2237.00
180	PERST_L	2058.50	2534.00	-2058.50	2534.00
181	RF_SW_CTRL_8	-1945.91	-806.00	1945.91	-806.00
182	GPIO_13	-2040.71	516.01	2040.71	516.01
183	RF_SW_CTRL_5	-1872.11	-1125.00	1872.11	-1125.00
184	RF_SW_CTRL_12	-1760.12	-327.01	1760.12	-327.01
185	GPIO_10	-1959.30	229.01	1959.30	229.01
186	RF_SW_CTRL_2	-1802.31	-1494.00	1802.31	-1494.00
187	RF_SW_CTRL_9	-1745.90	-806.00	1745.90	-806.00
188	GPIO_14	-1840.71	516.01	1840.71	516.01
189	GPIO_7	-1853.50	-18.00	1853.50	-18.00
190	RF_SW_CTRL_6	-1672.10	-1125.00	1672.10	-1125.00
191	RF_SW_CTRL_13	-1560.11	-327.01	1560.11	-327.01
192	GPIO_11	-1759.91	279.00	1759.91	279.00
193	RF_SW_CTRL_3	-1602.31	-1494.00	1602.31	-1494.00
194	RF_SW_CTRL_10	-1545.89	-806.00	1545.89	-806.00
195	GPIO_15	-1640.70	516.01	1640.70	516.01
196	GPIO_8	-1593.91	22.00	1593.91	22.00
197	RF_SW_CTRL_7	-1472.09	-1125.00	1472.09	-1125.00
198	RF_SW_CTRL_14	-1360.11	-327.01	1360.11	-327.01
199	GPIO_12	-1559.91	279.00	1559.91	279.00

**Table 21. 395-Bump WLCSP Coordinates (Cont.)**

No.	Net Name	Coordinates (0,0 center of die)			
		Bump Side		Top Side	
		X	Y	X	Y
200	VSSC	-459.00	1151.99	459.00	1151.99
201	VSSC	-459.00	1451.99	459.00	1451.99
202	RF_SW_CTRL_11	-1346.09	-756.00	1346.09	-756.00
203	VDDC	-459.00	1651.99	459.00	1651.99
204	VDDC	-1345.37	1017.54	1345.37	1017.54
205	GPIO_9	-1393.90	22.00	1393.90	22.00
206	VDDIO	-1215.90	576.00	1215.90	576.00
207	RF_SW_CTRL_15	-1160.10	-327.01	1160.10	-327.01
208	VDDC	-1261.10	1843.97	1261.10	1843.97
209	VDDC	-1061.11	-1156.00	1061.11	-1156.00
210	VDDC	-1061.11	-776.00	1061.11	-776.00
211	VDDC	-1061.10	-1355.99	1061.10	-1355.99
212	VDDC_ISO_PHY	-1402.10	-1494.00	1402.10	-1494.00
213	VDDC	-1180.10	-587.00	1180.10	-587.00
214	VDDC_ISO_PHY	-1151.11	-956.00	1151.11	-956.00
215	VDDC_ISO_DIG	-1058.99	2052.00	1058.99	2052.00
216	VDDC_ISO_DIG	-816.10	1843.97	816.10	1843.97
217	VSSC	-459.00	2052.00	459.00	2052.00
218	GPIO_0	-996.05	2877.58	996.05	2877.58
219	GPIO_1	-996.05	3077.59	996.05	3077.59
220	GPIO_2	-996.05	3277.59	996.05	3277.59
221	GPIO_3	-996.05	3477.60	996.05	3477.60
222	VDDIO	-990.90	576.00	990.90	576.00
223	VDDIO_RF	-960.10	-117.00	960.10	-117.00
224	VDDC	-1061.10	1843.97	1061.10	1843.97
225	VDDC_ISO_PHY	-1061.10	843.98	1061.10	843.98
226	VDDC_ISO_PHY	-1058.99	1151.99	1058.99	1151.99
227	VDDIO_RF	-852.10	-387.00	852.10	-387.00
228	VDDC	-461.11	-1355.99	461.11	-1355.99
229	GPIO_4	-769.05	3196.59	769.05	3196.59
230	VDDIO_PCIE	-759.00	252.00	759.00	252.00
231	VDDIO	-759.00	552.00	759.00	552.00
232	VSSC	-1359.90	279.00	1359.90	279.00
233	VSSC	-1319.39	2052.00	1319.39	2052.00
234	VSSC	-1358.99	2302.00	1358.99	2302.00
235	VSSC	-1351.11	-956.00	1351.11	-956.00
236	GPIO_6	-751.05	2996.59	751.05	2996.59
237	GPIO_5	-751.05	3396.60	751.05	3396.60
238	VDDIO_SD	-745.50	2352.00	745.50	2352.00
239	JTAG_SEL	-733.05	2796.58	733.05	2796.58



**Table 21. 395-Bump WLCSP Coordinates (Cont.)**

No.	Net Name	Coordinates (0,0 center of die)			
		Bump Side		Top Side	
		X	Y	X	Y
240	VDDC_ISO_PHY	-729.00	-220.50	729.00	-220.50
241	VDDC	-951.31	-956.00	951.31	-956.00
242	VDDC	-861.10	-1355.99	861.10	-1355.99
243	VSSC	-1440.90	576.00	1440.90	576.00
244	VSSC	-1159.90	-98.00	1159.90	-98.00
245	VSSC	-1159.90	279.00	1159.90	279.00
246	VDDC	-616.10	1843.97	616.10	1843.97
247	WRF_SYNTH_VBAT_VDD3P3	75.91	-3598.00	-75.91	-3598.00
248	WRF_XTAL_GND1P2	-2003.12	-1834.98	2003.12	-1834.98
249	WRF_XTAL_VDD1P5	-2003.12	-2065.65	2003.12	-2065.65
250	WRF_VCO_GND1P2	198.52	-3109.71	-198.52	-3109.71
251	WRF_XTAL_IN	-2205.82	-2065.65	2205.82	-2065.65
252	WRF_LOGEN_GND1P2	126.11	-2303.63	-126.11	-2303.63
253	WRF_XTAL_OUT	-2205.82	-1818.42	2205.82	-1818.42
254	WRF_XTAL_VDD1P2	-1807.98	-1960.54	1807.98	-1960.54
255	WRF_TX_GND1P2_CORE1	-437.83	-2417.93	437.83	-2417.93
256	WRF_BUCK_GND1P5_CORE1	-2137.36	-2823.85	2137.36	-2823.85
257	WRF_RX5G_GND1P2_CORE1	-1968.14	-2944.01	1968.14	-2944.01
258	WRF_GPIO_OUT_CORE1	-877.08	-2398.01	877.08	-2398.01
259	WRF_RX2G_GND1P2_CORE1	-167.27	-2716.52	167.27	-2716.52
260	WRF_RFIN_5G_CORE1	-2253.44	-3538.14	2253.44	-3538.14
261	WRF_RFIN_2G_CORE1	-201.47	-3598.00	201.47	-3598.00
262	WRF_PFD_VDD1P2	901.40	-2994.96	-901.40	-2994.96
263	WRF_PFD_GND1P2	818.12	-3198.01	-818.12	-3198.01
264	WRF_PADRV_VBAT_VDD3P3_CORE1	-1090.70	-2792.61	1090.70	-2792.61
265	WRF_PADRV_VBAT_GND3P3_CORE1	-1401.46	-2798.01	1401.46	-2798.01
266	WRF_PA5G_VBAT_VDD3P3_CORE1	-1401.46	-3679.00	1401.46	-3679.00
267	WRF_AFE_GND1P2_CORE1	-631.56	-2293.35	631.56	-2293.35
268	WRF_PA5G_VBAT_GND3P3_CORE0	1825.51	-2798.01	-1825.51	-2798.01
269	WRF_PA5G_VBAT_VDD3P3_CORE0	2297.50	-2998.01	-2297.50	-2998.01
270	WRF_MMD_VDD1P2	692.41	-2994.96	-692.41	-2994.96
271	WRF_MMD_GND1P2	499.12	-2798.01	-499.12	-2798.01
272	WRF_PA2G_VBAT_GND3P3_CORE0	1744.51	-1940.22	-1744.51	-1940.22
273	WRF_LNA_5G_GND1P2_CORE0	1877.39	-3673.49	-1877.39	-3673.49
274	WRF_CP_GND1P2	539.26	-3598.00	-539.26	-3598.00
275	WRF_LNA_2G_GND1P2_CORE0	1798.51	-1598.02	-1798.51	-1598.02
276	WRF_TSSI_A_CORE1	-1839.15	-2716.77	1839.15	-2716.77
277	WRF_BUCK_VDD1P5_CORE0	1024.35	-3433.91	-1024.35	-3433.91
278	WRF_LOGENG_GND1P2	770.31	-2353.01	-770.31	-2353.01
279	WRF_RFOUT_2G_CORE1	-601.47	-3679.00	601.47	-3679.00

**Table 21. 395-Bump WLCSP Coordinates (Cont.)**

No.	Net Name	Coordinates (0,0 center of die)			
		Bump Side		Top Side	
		X	Y	X	Y
280	WRF_RFOUT_5G_CORE0	2288.50	-3198.01	-2288.50	-3198.01
281	WRF_AFE_GND1P2_CORE0	880.13	-2028.11	-880.13	-2028.11
282	WRF_LNA_2G_GND1P2_CORE1	-201.47	-3198.01	201.47	-3198.01
283	WRF_LNA_5G_GND1P2_CORE1	-2276.94	-3276.89	2276.94	-3276.89
284	WRF_PA2G_VBAT_GND3P3_CORE1	-543.68	-3144.01	543.68	-3144.01
285	WRF_PA2G_VBAT_VDD3P3_CORE1	-801.47	-3697.00	801.47	-3697.00
286	WRF_PA5G_VBAT_GND3P3_CORE1	-1801.46	-3225.01	1801.46	-3225.01
287	WRF_PA5G_VBAT_VDD3P3_CORE0	2279.50	-2798.01	-2279.50	-2798.01
288	WRF_PADRV_VBAT_GND3P3_CORE0	1398.51	-2798.01	-1398.51	-2798.01
289	WRF_PADRV_VBAT_VDD3P3_CORE0	1393.11	-2487.25	-1393.11	-2487.25
290	WRF_RFIN_2G_CORE0	2198.50	-1598.02	-2198.50	-1598.02
291	WRF_RX2G_GND1P2_CORE0	1317.02	-1563.82	-1317.02	-1563.82
292	WRF_RX5G_GND1P2_CORE0	1544.51	-3364.69	-1544.51	-3364.69
293	WRF_TX_GND1P2_CORE0	1018.43	-1834.38	-1018.43	-1834.38
294	WRF_TSSI_A_CORE0	1317.27	-3235.69	-1317.27	-3235.69
295	WRF_BUCK_GND1P5_CORE0	1424.35	-3533.90	-1424.35	-3533.90
296	WRF_BUCK_VDD1P5_CORE1	-2237.36	-2423.85	2237.36	-2423.85
297	WRF_GPIO_OUT_CORE0	998.51	-2273.63	-998.51	-2273.63
298	WRF_RFOUT_2G_CORE0	2279.50	-1998.02	-2279.50	-1998.02
299	WRF_RFOUT_5G_CORE1	-1801.46	-3688.00	1801.46	-3688.00
300	WRF_PA2G_VBAT_GND3P3_CORE0	1714.63	-2523.25	-1714.63	-2523.25
301	WRF_PA2G_VBAT_GND3P3_CORE1	-1126.70	-3114.13	1126.70	-3114.13
302	WRF_RFIN_5G_CORE0	2138.64	-3649.99	-2138.64	-3649.99
303	WRF_PA5G_VBAT_GND3P3_CORE0	1825.51	-3198.01	-1825.51	-3198.01
304	WRF_PA5G_VBAT_GND3P3_CORE1	-1401.46	-3225.01	1401.46	-3225.01
305	WRF_PA2G_VBAT_VDD3P3_CORE0	2279.50	-2398.01	-2279.50	-2398.01
306	WRF_PA2G_VBAT_VDD3P3_CORE0	2297.50	-2198.02	-2297.50	-2198.02
307	WRF_RX2G_GND1P2_CORE0	1488.79	-1700.51	-1488.79	-1700.51
308	WRF_BUCK_VDD1P5_CORE0	1024.35	-3633.90	-1024.35	-3633.90
309	WRF_BUCK_VDD1P5_CORE0	1224.35	-3633.90	-1224.35	-3633.90
310	WRF_BUCK_VDD1P5_CORE0	1224.35	-3433.91	-1224.35	-3433.91
311	WRF_BUCK_VDD1P5_CORE1	-2037.36	-2423.85	2037.36	-2423.85
312	WRF_BUCK_VDD1P5_CORE1	-2037.36	-2623.85	2037.36	-2623.85
313	WRF_BUCK_VDD1P5_CORE1	-2237.36	-2623.85	2237.36	-2623.85
314	WRF_PA5G_VBAT_VDD3P3_CORE1	-1601.46	-3697.00	1601.46	-3697.00
315	WRF_PA2G_VBAT_VDD3P3_CORE1	-1001.47	-3679.00	1001.47	-3679.00
316	WRF_LOGEN_GND1P2	326.11	-2303.63	-326.11	-2303.63
317	WRF_RX2G_GND1P2_CORE1	-303.96	-2888.29	303.96	-2888.29
318	WRF_CP_GND1P2	339.26	-3598.00	-339.26	-3598.00
319	WL_REG_ON	-1710.77	3277.01	1710.77	3277.01

**Table 21. 395-Bump WLCSP Coordinates (Cont.)**

No.	Net Name	Coordinates (0,0 center of die)			
		Bump Side		Top Side	
		X	Y	X	Y
320	BT_REG_ON	-1569.35	1721.37	1569.35	1721.37
321	LDO_VDDBAT5V	-1852.20	1721.37	1852.20	1721.37
322	LDO_VDDBAT5V	-1852.20	1438.53	1852.20	1438.53
323	LDO_VDDBAT5V	-1852.20	1155.69	1852.20	1155.69
324	VOUT_3P3	-1993.62	1297.11	1993.62	1297.11
325	VOUT_3P3	-2135.04	1155.69	2135.04	1155.69
326	VDDIO_PMU	-1710.77	1297.11	1710.77	1297.11
327	LDO_VDDBAT5V	-1852.20	872.84	1852.20	872.84
328	LDO_VDDBAT5V	-2135.04	872.84	2135.04	872.84
329	LDO_VDDBAT5V	-2276.46	1014.26	2276.46	1014.26
330	VOUT_3P3_SENSE	-2276.46	1297.11	2276.46	1297.11
331	LDO_VDDBAT5V	-1710.77	1862.79	1710.77	1862.79
332	VOUT_3P3	-1993.62	1579.95	1993.62	1579.95
333	VSSC	-1569.35	1155.69	1569.35	1155.69
334	VSSC	-1569.35	1438.53	1569.35	1438.53
335	PMU_AVSS	-1569.35	2287.06	1569.35	2287.06
336	SR_VLX	-1569.35	2852.74	1569.35	2852.74
337	SR_VLX	-1569.35	3135.59	1569.35	3135.59
338	SR_PVSS	-1852.20	3135.59	1852.20	3135.59
339	SR_VLX	-1852.20	2852.74	1852.20	2852.74
340	SR_VDDBATA5V	-1852.20	2569.90	1852.20	2569.90
341	VOUT_CLDO	-1852.20	2287.06	1852.20	2287.06
342	LDO_VDD1P5	-1852.20	2004.21	1852.20	2004.21
343	LDO_VDDBAT5V	-1993.62	1014.26	1993.62	1014.26
344	VOUT_3P3	-2135.04	1438.53	2135.04	1438.53
345	LDO_VDDBAT5V	-2135.04	1721.37	2135.04	1721.37
346	VOUT_LDO3P3_B	-2135.04	2004.21	2135.04	2004.21
347	LDO_VDD1P5	-2135.04	2287.06	2135.04	2287.06
348	SR_VDDBATP5V	-2135.04	2569.90	2135.04	2569.90
349	SR_PVSS	-2135.04	3135.59	2135.04	3135.59
350	VDDIO_PMU	-1710.77	1579.95	1710.77	1579.95
351	VOUT_LNLDO	-1710.77	2145.64	1710.77	2145.64
352	VOUT_CLDO	-1710.77	2428.48	1710.77	2428.48
353	SR_VLX	-1710.77	2711.32	1710.77	2711.32
354	SR_VLX	-1710.77	2994.17	1710.77	2994.17
355	VOUT_LDO3P3_B	-1993.62	1862.79	1993.62	1862.79
356	LDO_VDD1P5	-1993.62	2145.64	1993.62	2145.64
357	VOUT_CLDO	-1993.62	2428.48	1993.62	2428.48
358	SR_VDDBATP5V	-1993.62	2711.32	1993.62	2711.32
359	SR_VLX	-1993.62	2994.17	1993.62	2994.17

**Table 21. 395-Bump WLCSP Coordinates (Cont.)**

No.	Net Name	Coordinates (0,0 center of die)			
		Bump Side		Top Side	
		X	Y	X	Y
360	SR_PVSS	-1993.62	3277.01	1993.62	3277.01
361	VOUT_3P3	-2276.46	1862.79	2276.46	1862.79
362	VOUT_BTLDO2P5	-2276.46	2145.64	2276.46	2145.64
363	LDO_VDD1P5	-2276.46	2428.48	2276.46	2428.48
364	SR_PVSS	-2276.46	3277.01	2276.46	3277.01
365	VOUT_3P3	-2276.46	1579.95	2276.46	1579.95
366	SR_VDDBATP5V	-2276.46	2711.32	2276.46	2711.32
367	PCIE_TESTP	1800.31	3068.53	-1800.31	3068.53
368	PCIE_TESTN	1966.81	2956.03	-1966.81	2956.03
369	BT_VDDC	1480.37	1005.66	-1480.37	1005.66
370	BT_VDDC	1480.37	1225.66	-1480.37	1225.66
371	BT_VDDC	1408.19	248.05	-1408.19	248.05
372	BT_VDDC	1322.34	55.02	-1322.34	55.02
373	BT_VDDC	1060.28	-1186.86	-1060.28	-1186.86
374	BT_VDDC	666.40	-198.15	-666.40	-198.15
375	BT_VDDC	617.61	-1324.61	-617.61	-1324.61
376	BT_VSSC	338.89	-475.07	-338.89	-475.07
377	BT_VSSC	1040.28	-724.53	-1040.28	-724.53
378	BT_VSSC	1063.38	1020.66	-1063.38	1020.66
379	BT_VSSC	1063.38	1320.66	-1063.38	1320.66
380	BT_VSSC	1273.37	505.67	-1273.37	505.67
381	BT_VSSC	1273.37	705.66	-1273.37	705.66
382	BT_VSSC	1273.37	1005.66	-1273.37	1005.66
383	BT_VSSC	1273.37	1225.66	-1273.37	1225.66
384	VSSC	440.99	2052.00	-440.99	2052.00
385	VSSC	-1293.24	-1317.60	1293.24	-1317.60
386	VSSC	-1202.10	-1504.00	1202.10	-1504.00
387	VSSC	-1058.99	1451.99	1058.99	1451.99
388	VSSC	-1058.99	2302.00	1058.99	2302.00
389	VSSC	-959.90	279.00	959.90	279.00
390	VSSC	-759.00	851.99	759.00	851.99
391	VSSC	-759.00	1151.99	759.00	1151.99
392	VSSC	-759.00	1451.99	759.00	1451.99
393	VSSC	-759.00	2052.00	759.00	2052.00
394	VSSC	-746.31	-956.00	746.31	-956.00
395	VSSC	-746.31	-756.00	746.31	-756.00

### 13.3 Signal Descriptions

The signal name, type, and description of each pin in the CYW4356 is listed in [Table 22](#) and [Table 23](#). The symbols shown under Type indicate pin directions (I/O = bidirectional, I = input, O = output) and the internal pull-up/pull-down characteristics (PU = weak internal pull-up resistor and PD = weak internal pull-down resistor), if any.

**Table 22. WLCSP Signal Descriptions**

Bump#	Signal Name	Type	Description
<b>WLAN and Bluetooth Receive RF Signal Interface</b>			
290	WRF_RFIN_2G_CORE0	I	2.4 GHz Bluetooth and WLAN CORE0 receiver shared input
261	WRF_RFIN_2G_CORE1	I	2.4 GHz Bluetooth and WLAN CORE1 receiver shared input
302	WRF_RFIN_5G_CORE0	I	5 GHz WLAN CORE0 receiver input
260	WRF_RFIN_5G_CORE1	I	5 GHz WLAN CORE1 receiver input
298	WRF_RFOUT_2G_CORE0	O	2.4 GHz WLAN CORE0 PA output
279	WRF_RFOUT_2G_CORE1	O	2.4 GHz WLAN CORE1 PA output
280	WRF_RFOUT_5G_CORE0	O	5 GHz WLAN CORE0 PA output
299	WRF_RFOUT_5G_CORE1	O	5 GHz WLAN CORE1 PA output
294	WRF_TSSI_A_CORE0	I	5 GHz TSSI CORE0 input from an optional external power amplifier/power detector.
276	WRF_TSSI_A_CORE1	I	5 GHz TSSI CORE1 input from an optional external power amplifier/power detector.
297	WRF_GPIO_OUT_CORE0	I/O	GPIO or 2.4 GHz TSSI CORE0 input from an optional external power amplifier/power detector
258	WRF_GPIO_OUT_CORE1	I/O	GPIO or 2.4 GHz TSSI CORE1 input from an optional external power amplifier/power detector
<b>RF Switch Control Lines</b>			
66	RF_SW_CTRL_0	O	Programmable RF switch control lines. The control lines are programmable via the driver and NVRAM file.
175	RF_SW_CTRL_1	O	
186	RF_SW_CTRL_2	O	
193	RF_SW_CTRL_3	O	
86	RF_SW_CTRL_4	O	
183	RF_SW_CTRL_5	O	
190	RF_SW_CTRL_6	O	
197	RF_SW_CTRL_7	O	
181	RF_SW_CTRL_8	O	
187	RF_SW_CTRL_9	O	
194	RF_SW_CTRL_10	O	
202	RF_SW_CTRL_11	O	
184	RF_SW_CTRL_12	O	
191	RF_SW_CTRL_13	O	
198	RF_SW_CTRL_14	O	
207	RF_SW_CTRL_15	O	
<b>WLAN PCI Express Interface</b>			
174	PCIE_CLKREQ_L	OD	PCIe clock request signal which indicates when the REFCLK to the PCIe interface can be gated. 1 = the clock can be gated 0 = the clock is required

**Table 22. WLCSP Signal Descriptions (Cont.)**

Bump#	Signal Name	Type	Description
180	PCIE_PERST_L	I (PU)	PCIe System Reset. This input is the PCIe reset as defined in the PCIe base specification version 1.1.
9	PCIE_RDN0	I	Receiver differential pair (×1 lane)
8	PCIE_RDP0	I	
4	PCIE_REFCLKN	I	PCIe Differential Clock inputs (negative and positive). 100 MHz differential.
3	PCIE_REFCLKP	I	
5	PCIE_TDN0	O	Transmitter differential pair (×1 lane)
6	PCIE_TDP0	O	
165	PCIE_PME_L	OD	PCI power management event output. Used to request a change in the device or system power state. The assertion and deassertion of this signal is asynchronous to the PCIe reference clock. This signal has an open-drain output structure, as per the PCI Bus Local Bus Specification, revision 2.3.
367	PCIE_TESTP	–	PCIe test pin
368	PCIE_TESTN	–	
<b>WLAN SDIO Bus Interface</b>			
These signals can support alternate functionality depending on package and host interface mode. See <a href="#">Table 27</a> .			
78	SDIO_CLK	I	SDIO clock input
81	SDIO_CMD	I/O	SDIO command line
82	SDIO_DATA_0	I/O	SDIO data line 0
77	SDIO_DATA_1	I/O	SDIO data line 1
80	SDIO_DATA_2	I/O	SDIO data line 2
79	SDIO_DATA_3	I/O	SDIO data line 3
<b>WLAN GPIO Interface</b>			
The GPIO signals can be multiplexed via software and the JTAG_SEL pin to support other functions. See <a href="#">Table 24</a> and <a href="#">Table 27</a> for additional details.			
218	GPIO_0	I/O	Programmable GPIO pins
219	GPIO_1	I/O	
220	GPIO_2	I/O	
221	GPIO_3	I/O	
229	GPIO_4	I/O	
237	GPIO_5	I/O	
236	GPIO_6	I/O	
189	GPIO_7	I/O	
196	GPIO_8	I/O	
205	GPIO_9	I/O	
185	GPIO_10	I/O	
192	GPIO_11	I/O	
199	GPIO_12	I/O	
182	GPIO_13	I/O	
188	GPIO_14	I/O	
195	GPIO_15	I/O	

**Table 22. WLCSP Signal Descriptions (Cont.)**

Bump#	Signal Name	Type	Description
<b>JTAG Interface</b>			
239	JTAG_SEL	I/O	JTAG select: pull high to select the JTAG interface. If the JTAG interface is not used this pin may be left floating or connected to ground. <b>Note:</b> See <a href="#">Table 27</a> for the JTAG signal pins.
<b>Clocks</b>			
251	WRF_XTAL_IN	I	XTAL oscillator input
253	WRF_XTAL_OUT	O	XTAL oscillator output
159	LPO_IN	I	External sleep clock input (32.768 kHz)
161	CLK_REQ	O	Reference clock request (shared by BT and WLAN). If not used, this can be no-connect.
<b>Bluetooth/FM Transceiver</b>			
49	BT_RF	O	Bluetooth PA output
61	FM_RFIN	I	FM radio antenna port
60	FM_RFAUX	I	FM radio auxiliary antenna port
54	FM_AOUT1	O	FM DAC output 1
55	FM_AOUT2	O	FM DAC output 2
<b>Bluetooth PCM</b>			
179	BT_PCM_CLK	I/O	PCM clock; can be master (output) or slave (input)
173	BT_PCM_IN	I	PCM data input
177	BT_PCM_OUT	O	PCM data output
163	BT_PCM_SYNC	I/O	PCM sync; can be master (output) or slave (input).
<b>Bluetooth USB Interface</b>			
164	BT_USB_DN	I/O	USB (Host) data negative. Negative terminal of the USB transceiver.
169	BT_USB_DP	I/O	USB (Host) data positive. Positive terminal of the USB transceiver.
<b>Bluetooth UART</b>			
172	BT_UART_CTS_L	I	UART clear-to-send. Active-low clear-to-send signal for the HCI UART interface.
178	BT_UART_RTS_L	O	UART request-to-send. Active-low request-to-send signal for the HCI UART interface. BT LED control pin.
162	BT_UART_RXD	I	UART serial input. Serial data input for the HCI UART interface.
157	BT_UART_TXD	O	UART serial output. Serial data output for the HCI UART interface.
<b>Bluetooth/FM I<sup>2</sup>S</b>			
167	BT_I2S_CLK	I/O	I <sup>2</sup> S clock, can be master (output) or slave (input).
171	BT_I2S_DO	I/O	I <sup>2</sup> S data output
156	BT_I2S_DI	I/O	I <sup>2</sup> S data input
158	BT_I2S_WS	I/O	I <sup>2</sup> S WS; can be master (output) or slave (input).
<b>Bluetooth GPIOs</b>			
155	BT_GPIO_2	I/O	Bluetooth general-purpose I/O

**Table 22. WLCSP Signal Descriptions (Cont.)**

Bump#	Signal Name	Type	Description
154	BT_GPIO_3	I/O	Bluetooth general-purpose I/O
168	BT_GPIO_4	I/O	Bluetooth general-purpose I/O
153	BT_GPIO_5	I/O	Bluetooth general-purpose I/O
<b>Miscellaneous</b>			
319	WL_REG_ON	I	Used by PMU to power up or power down the internal CYW4356 regulators used by the WLAN section. Also, when deasserted, this pin holds the WLAN section in reset. This pin has an internal 200 kΩ pull-down resistor that is enabled by default. It can be disabled through programming.
320	BT_REG_ON	I	Used by PMU to power up or power down the internal CYW4356 regulators used by the Bluetooth/FM section. Also, when deasserted, this pin holds the Bluetooth/FM section in reset. This pin has an internal 200 kΩ pull-down resistor that is enabled by default. It can be disabled through programming.
176	BT_DEV_WAKE	I/O	Bluetooth DEV_WAKE
170	BT_HOST_WAKE	I/O	Bluetooth HOST_WAKE
12–29, 99–101, 31, 33, 35, 38	NC	NC	Do not connect these pins to anything. Leave them floating.
<b>Integrated Voltage Regulators</b>			
340	SR_VDDBATA5V	I	Quiet VBAT
348	SR_VDDBATP5V	I	Power VBAT
336	SR_VLX	O	Cbuck switching regulator output. Refer to <a href="#">Table 44</a> for details of the inductor and capacitor required on this output.
342	LDO_VDD1P5	I	LNLDO input
327	LDO_VDDBAT5V	I	LDO VBAT.
249	WRF_XTAL_VDD1P5	I	XTAL LDO input (1.35V)
254	WRF_XTAL_VDD1P2	O	XTAL LDO output (1.2V)
351	VOUT_LNLDO	O	Output of LNLDO
341	VOUT_CLDO	O	Output of core LDO
362	VOUT_BTLDO2P5	O	Output of BT LDO
346	VOUT_LDO3P3_B	O	Output of 3.3V LDO
324	VOUT_3P3	O	LDO 3.3V output
330	VOUT_3P3_SENSE	O	Voltage sense pin for LDO 3.3V output
<b>Bluetooth Supplies</b>			
46	BT_PAVDD2P5	PWR	Bluetooth PA power supply
44	BT_LNAVDD1P2	PWR	Bluetooth LNA power supply
42	BT_IFVDD1P2	PWR	Bluetooth IF block power supply
47	BT_PLLVDD1P2	PWR	Bluetooth RF PLL power supply
50	BT_VCOVDD1P2	PWR	Bluetooth RF power supply
148, 149, 150, 151	BT_VDDIO	PWR	Core supply



**Table 22. WLCSP Signal Descriptions (Cont.)**

Bump#	Signal Name	Type	Description
<b>FM Transceiver Supplies</b>			
–	FM_LNAVCOVDD1P2	PWR	FM LNA and VCO 1.2V power supply
62	FM_LNAVDD1P2	PWR	FM LNA 1.2V power supply
64	FM_VCOVDD1P2	PWR	FM VCO 1.2V power supply
59	FM_PLLVDD1P2	PWR	FM PLL 1.2V power supply
52	FM_AUDIOVDD1P2	PWR	FM AUDIO power supply
<b>WLAN Supplies</b>			
277	WRF_BUCK_VDD1P5_CORE0	PWR	Internal capacitor-less CORE0 LDO supply
296	WRF_BUCK_VDD1P5_CORE1	PWR	Internal capacitor-less CORE1 LDO supply
262	WRF_SYNTH_VBAT_VDD3P3	PWR	Synth VDD 3.3V supply
289	WRF_PADRV_VBAT_VDD3P3_CORE0	PWR	CORE0 PA Driver VBAT supply
264	WRF_PADRV_VBAT_VDD3P3_CORE1	PWR	CORE1 PA Driver VBAT supply
269	WRF_PA5G_VBAT_VDD3P3_CORE0	PWR	5 GHz CORE0 PA 3.3V VBAT supply
266	WRF_PA5G_VBAT_VDD3P3_CORE1	PWR	5 GHz CORE1 PA 3.3V VBAT supply
305	WRF_PA2G_VBAT_VDD3P3_CORE0	PWR	2 GHz CORE0 PA 3.3V VBAT supply
285	WRF_PA2G_VBAT_VDD3P3_CORE1	PWR	2 GHz CORE1 PA 3.3V VBAT supply
270	WRF_MMD_VDD1P2	PWR	1.2V supply
262	WRF_PFD_VDD1P2	PWR	1.2V supply

**Table 22. WLCSP Signal Descriptions (Cont.)**

Bump#	Signal Name	Type	Description
<b>Miscellaneous Supplies</b>			
160	OTP_VDD33	PWR	OTP 3.3V supply
67, 74, 87, 103, 107– 115, 127– 129, 134– 140, 203, 204, 208– 211, 213, 224, 228, 241, 242, 246	VDDC	PWR	1.2V core supply for WLAN
206, 222, 231	VDDIO	PWR	1.8V–3.3V supply for WLAN. Must be directly connected to PMU_VDDIO and BT_VDDIO on the PCB.
145, 147, 369–375,	BT_VDDC	PWR	1.2V core supply for BT
326	VDDIO_PMU	PWR	1.8V–3.3V supply for PMU controls. Must be directly connected to VDDIO and BT_VDDIO on the PCB.
76	VDDIO_SD	PWR	1.8V–3.3V supply for SDIO pads and PCIe out-of-band signals.
223	VDDIO_RF	PWR	IO supply for RF switch control pads (3.3V).
98	VDDC_98	PWR	1.2V supply from VOUT_CLDO (341, 352, 357).
102	VDDC_102	PWR	1.2V supply from VOUT_CLDO (341, 352, 357).
143	AVDD_BBPLL	PWR	Baseband PLL supply.
11	PCIE_PLL_AVDD1P2	PWR	1.2V supply for PCIe PLL. (This pin should be left unconnected (NC) for SDIO operation.)
7	PCIE_RXTX_AVDD1P2	PWR	1.2V supply for PCIe TX and RX. (This pin should be left unconnected (NC) for SDIO operation.)
230	VDDIO_PCIE	PWR	Supply the same voltage to this pin as that used for the PCIe out-of-band signals (that is, PCIE_PME_L).
<b>Ground</b>			
250	WRF_VCO_GND1P2	GND	VCO/LOGEN ground
281	WRF_AFE_GND1P2_CORE0	GND	CORE0 AFE ground
267	WRF_AFE_GND1P2_CORE1	GND	CORE1 AFE ground
295	WRF_BUCK_GND1P5_CORE0	GND	Internal capacitor-less CORE0 LDO ground
256	WRF_BUCK_GND1P5_CORE1	GND	Internal capacitor-less CORE1 LDO ground
275	WRF_LNA_2G_GND1P2_CORE0	GND	2 GHz internal CORE0 LNA ground
282	WRF_LNA_2G_GND1P2_CORE1	GND	2 GHz internal CORE1 LNA ground
273	WRF_LNA_5G_GND1P2_CORE0	GND	5 GHz internal CORE0 LNA ground
283	WRF_LNA_5G_GND1P2_CORE1	GND	5 GHz internal CORE1 LNA ground
293	WRF_TX_GND1P2_CORE0	GND	TX CORE0 ground
255	WRF_TX_GND1P2_CORE1	GND	TX CORE1 ground
288	WRF_PADRV_VBAT_GND3P3_CORE0	GND	PAD CORE0 ground
265	WRF_PADRV_VBAT_GND3P3_CORE1	GND	PAD CORE1 ground
248	WRF_XTAL_GND1P2	GND	XTAL ground
291, 307	WRF_RX2G_GND1P2_CORE0	GND	RX 2GHz CORE0 ground

**Table 22. WLCSP Signal Descriptions (Cont.)**

Bump#	Signal Name	Type	Description
259, 317	WRF_RX2G_GND1P2_CORE1	GND	RX 2GHz CORE1 ground
292	WRF_RX5G_GND1P2_CORE0	GND	RX 5GHz CORE0 ground
257	WRF_RX5G_GND1P2_CORE1	GND	RX 5GHz CORE1 ground
252, 316	WRF_LOGEN_GND1P2	GND	LOGEN ground
278	WRF_LOGENG_GND1P2	GND	LOGEN ground
268, 030	WRF_PA5G_VBAT_GND3P3_CORE0	GND	5 GHz PA CORE0 ground
286, 304	WRF_PA5G_VBAT_GND3P3_CORE1	GND	5 GHz PA CORE1 ground
272, 300	WRF_PA2G_VBAT_GND3P3_CORE0	GND	2 GHz PA CORE0 ground
284, 301	WRF_PA2G_VBAT_GND3P3_CORE1	GND	2 GHz PA CORE1 ground
271	WRF_MMD_GND1P2	GND	Ground
274, 318	WRF_CP_GND1P2	GND	Ground
263	WRF_PFD_GND1P2	GND	Ground
68–73, 75, 83–85, 88–95, 104–106, 116–122, 130, 200, 201, 217, 232–235, 254–245, 333, 334, 384–395	VSSC	GND	Core ground for WLAN and BT
338, 349, 360, 364	SR_PVSS	GND	Power ground
335	PMU_AVSS	GND	Quiet ground
30, 32, 34, 36, 37, 39, 96, 97	GND	GND	–
40	BT_PAVSS	GND	Bluetooth PA ground
43	BT_IFVSS	GND	Bluetooth IF block ground
48	BT_PLLVSS	GND	Bluetooth PLL ground
51	BT_VCOVSS	GND	Bluetooth VCO ground
65	FM_VCOVSS	GND	FM VCO ground
63	FM_LNAVSS	GND	FM LNA ground
58	FM_PLLVSS	GND	FM PLL ground
53	FM_AUDIOVSS	GND	FM AUDIO ground
144	AVSS_BBPLL	GND	Baseband PLL ground
10	PCIE_AVSS	GND	PCIE ground
1	PCIE_RXTX_AVSS	GND	PCIE ground
2	PCIE_PLL_AVSS	GND	PCIE ground
17, 18, 23, 26	RGND	GND	Ground
–	BTRGND	GND	Ground

**Table 23. WLBGA Signal Descriptions**

Ball#	Signal Name	Type	Description
<b>WLAN and Bluetooth Receive RF Signal Interface</b>			
N1	WRF_RFIN_2G_CORE0	I	2.4 GHz Bluetooth and WLAN CORE0 receiver shared input
V7	WRF_RFIN_2G_CORE1	I	2.4 GHz Bluetooth and WLAN CORE1 receiver shared input
V1	WRF_RFIN_5G_CORE0	I	5 GHz WLAN CORE0 receiver input
V12	WRF_RFIN_5G_CORE1	I	5 GHz WLAN CORE1 receiver input
P1	WRF_RFOUT_2G_CORE0	O	2.4 GHz WLAN CORE0 PA output
V8	WRF_RFOUT_2G_CORE1	O	2.4 GHz WLAN CORE1 PA output
U1	WRF_RFOUT_5G_CORE0	O	5 GHz WLAN CORE0 PA output
V11	WRF_RFOUT_5G_CORE1	O	5 GHz WLAN CORE1 PA output
U3	WRF_TSSI_A_CORE0	I	5 GHz TSSI CORE0 input from an optional external power amplifier/power detector.
T11	WRF_TSSI_A_CORE1	I	5 GHz TSSI CORE1 input from an optional external power amplifier/power detector.
R4	WRF_GPIO_OUT_CORE0	I/O	GPIO or 2.4 GHz TSSI CORE0 input from an optional external power amplifier/power detector
R9	WRF_GPIO_OUT_CORE1	I/O	GPIO or 2.4 GHz TSSI CORE1 input from an optional external power amplifier/power detector
<b>RF Switch Control Lines</b>			
R7	RF_SW_CTRL_0	O	Programmable RF switch control lines. The control lines are programmable via the driver and NVRAM file.
N8	RF_SW_CTRL_1	O	
P9	RF_SW_CTRL_2	O	
N7	RF_SW_CTRL_3	O	
N5	RF_SW_CTRL_4	O	
P7	RF_SW_CTRL_5	O	
P5	RF_SW_CTRL_6	O	
M8	RF_SW_CTRL_7	O	
K12	RF_SW_CTRL_8	O	
J11	RF_SW_CTRL_9	O	
M12	RF_SW_CTRL_10	O	
L9	RF_SW_CTRL_11	O	
J9	RF_SW_CTRL_12	O	
K10	RF_SW_CTRL_13	O	
M10	RF_SW_CTRL_14	O	
L8	RF_SW_CTRL_15	O	
<b>WLAN PCI Express Interface</b>			
D5	PCIE_CLKREQ_L	OD	PCIe clock request signal which indicates when the REFCLK to the PCIe interface can be gated. 1 = the clock can be gated 0 = the clock is required
C4	PCIE_PERST_L	I (PU)	PCIe System Reset. This input is the PCIe reset as defined in the PCIe base specification version 1.1.

**Table 23. WLBGA Signal Descriptions (Cont.)**

Ball#	Signal Name	Type	Description
B1	PCIE_RDN0	I	Receiver differential pair (×1 lane)
C1	PCIE_RDP0	I	
A5	PCIE_REFCLKN	I	PCIE Differential Clock inputs (negative and positive). 100 MHz differential.
A4	PCIE_REFCLKP	I	
A3	PCIE_TDN0	O	Transmitter differential pair (×1 lane)
A2	PCIE_TDP0	O	
C5	PCIE_PME_L	OD	PCI power management event output. Used to request a change in the device or system power state. The assertion and deassertion of this signal is asynchronous to the PCIe reference clock. This signal has an open-drain output structure, as per the PCI Bus Local Bus Specification, revision 2.3.
C3	PCIE_TESTP	–	PCIe test pin
C2	PCIE_TESTN	–	
<b>WLAN SDIO Bus Interface</b>			
<b>Note:</b> These signals can support alternate functionality depending on package and host interface mode. See <a href="#">Table 27</a> for additional details.			
A8	SDIO_CLK	I	SDIO clock input
A9	SDIO_CMD	I/O	SDIO command line
B9	SDIO_DATA_0	I/O	SDIO data line 0
C9	SDIO_DATA_1	I/O	SDIO data line 1
B8	SDIO_DATA_2	I/O	SDIO data line 2
C8	SDIO_DATA_3	I/O	SDIO data line 3
<b>WLAN GPIO Interface</b>			
<b>Note:</b> The GPIO signals can be multiplexed via software and the JTAG_SEL pin to support other functions. See <a href="#">Table 24</a> and <a href="#">Table 27</a> for additional details.			
G11	GPIO_0	I/O	Programmable GPIO pins
F10	GPIO_1	I/O	
F11	GPIO_2	I/O	
G9	GPIO_3	I/O	
H9	GPIO_4	I/O	
F9	GPIO_5	I/O	
F8	GPIO_6	I/O	
E7	GPIO_7	I/O	
F7	GPIO_8	I/O	
E6	GPIO_9	I/O	
H12	GPIO_10	I/O	
–	GPIO_11	I/O	
–	GPIO_12	I/O	
–	GPIO_13	I/O	
–	GPIO_14	I/O	
–	GPIO_15	I/O	

**Table 23. WLBGA Signal Descriptions (Cont.)**

Ball#	Signal Name	Type	Description
<b>JTAG Interface</b>			
D9	JTAG_SEL	I/O	JTAG select: pull high to select the JTAG interface. If the JTAG interface is not used this pin may be left floating or connected to ground. See <a href="#">Table 27</a> for the JTAG signal pins.
<b>Clocks</b>			
P12	WRF_XTAL_IN	I	XTAL oscillator input
N12	WRF_XTAL_OUT	O	XTAL oscillator output
F6	LPO_IN	I	External sleep clock input (32.768 kHz)
F4	CLK_REQ	O	Reference clock request (shared by BT and WLAN). If not used, this can be no-connect.
<b>Bluetooth/FM Transceiver</b>			
L1	BT_RF	O	Bluetooth PA output
H1	FM_RFIN	I	FM radio antenna port
–	FM_RFAUX	I	FM radio auxiliary antenna port
E1	FM_AOUT1	O	FM DAC output 1
F1	FM_AOUT2	O	FM DAC output 2
<b>Bluetooth PCM</b>			
M6	BT_PCM_CLK	I/O	PCM clock; can be master (output) or slave (input)
J4	BT_PCM_IN	I	PCM data input
H4	BT_PCM_OUT	O	PCM data output
K6	BT_PCM_SYNC	I/O	PCM sync; can be master (output) or slave (input).
<b>Bluetooth USB Interface</b>			
E5	BT_USB_DN	I/O	USB (Host) data negative. Negative terminal of the USB transceiver.
F5	BT_USB_DP	I/O	USB (Host) data positive. Positive terminal of the USB transceiver.
<b>Bluetooth UART</b>			
L5	BT_UART_CTS_L	I	UART clear-to-send. Active-low clear-to-send signal for the HCI UART interface.
K5	BT_UART_RTS_L	O	UART request-to-send. Active-low request-to-send signal for the HCI UART interface. BT LED control pin.
H5	BT_UART_RXD	I	UART serial input. Serial data input for the HCI UART interface.
J5	BT_UART_TXD	O	UART serial output. Serial data output for the HCI UART interface.
<b>Bluetooth/FM I<sup>2</sup>S</b>			
J6	BT_I2S_CLK	I/O	I <sup>2</sup> S clock, can be master (output) or slave (input).
G6	BT_I2S_DO	I/O	I <sup>2</sup> S data output
G5	BT_I2S_DI	I/O	I <sup>2</sup> S data input
L6	BT_I2S_WS	I/O	I <sup>2</sup> S WS; can be master (output) or slave (input).

**Table 23. WLBGA Signal Descriptions (Cont.)**

Ball#	Signal Name	Type	Description
<b>Bluetooth GPIO</b>			
A6	BT_GPIO_2	I/O	Bluetooth general-purpose I/O
D7	BT_GPIO_3	I/O	Bluetooth general-purpose I/O
K4	BT_GPIO_4	I/O	Bluetooth general-purpose I/O
A7	BT_GPIO_5	I/O	Bluetooth general-purpose I/O
<b>Miscellaneous</b>			
A10	WL_REG_ON	I	Used by PMU to power up or power down the internal CYW4356 regulators used by the WLAN section. Also, when deasserted, this pin holds the WLAN section in reset. This pin has an internal 200 kΩ pull-down resistor that is enabled by default. It can be disabled through programming.
D10	BT_REG_ON	I	Used by PMU to power up or power down the internal CYW4356 regulators used by the Bluetooth/FM section. Also, when deasserted, this pin holds the Bluetooth/FM section in reset. This pin has an internal 200 kΩ pull-down resistor that is enabled by default. It can be disabled through programming.
L4	BT_DEV_WAKE	I/O	Bluetooth DEV_WAKE
J3	BT_HOST_WAKE	I/O	Bluetooth HOST_WAKE
<b>Integrated Voltage Regulators</b>			
B11	SR_VDDBATA5V	I	Quiet VBAT
B12	SR_VDDBATP5V	I	Power VBAT
A11	SR_VLX	O	Cbuck switching regulator output. Refer to <a href="#">Table 44</a> for details of the inductor and capacitor required on this output.
C12	LDO_VDD1P5	I	LNLDO input
E12	LDO_VDDBAT5V	I	LDO VBAT.
P11	WRF_XTAL_VDD1P5	I	XTAL LDO input (1.35V)
N10	WRF_XTAL_VDD1P2	O	XTAL LDO output (1.2V)
D11	VOUT_LNLDO	O	Output of LNLDO
C11	VOUT_CLDO	O	Output of core LDO
D12	VOUT_BTLDO2P5	O	Output of BT LDO
E11	VOUT_LDO3P3_B	O	Output of 3.3V LDO
F12	VOUT_3P3	O	LDO 3.3V output
–	VOUT_3P3_SENSE	O	Voltage sense pin for LDO 3.3V output
<b>Bluetooth Supplies</b>			
M1	BT_PAVDD2P5	PWR	Bluetooth PA power supply
K1	BT_LNAVDD1P2	PWR	Bluetooth LNA power supply
K3	BT_IFVDD1P2	PWR	Bluetooth IF block power supply
K2	BT_PLLVDD1P2	PWR	Bluetooth RF PLL power supply
J1	BT_VCOVDD1P2	PWR	Bluetooth RF power supply
K7	BT_VDDIO	PWR	Core supply
<b>FM Transceiver Supplies</b>			
G1	FM_LNAVCOVDD1P2	PWR	FM LNA and VCO 1.2V power supply

**Table 23. WLBGA Signal Descriptions (Cont.)**

Ball#	Signal Name	Type	Description
–	FM_LNAVDD1P2	PWR	FM LNA 1.2V power supply
–	FM_VCOVDD1P2	PWR	FM VCO 1.2V power supply
F3	FM_PLLVDD1P2	PWR	FM PLL 1.2V power supply
E2	FM_AUDIOVDD1P2	PWR	FM AUDIO power supply
<b>WLAN Supplies</b>			
U4	WRF_BUCK_VDD1P5_CORE0	PWR	Internal capacitor-less CORE0 LDO supply
R11	WRF_BUCK_VDD1P5_CORE1	PWR	Internal capacitor-less CORE1 LDO supply
V6	WRF_SYNTH_VBAT_VDD3P3	PWR	Synth VDD 3.3V supply
R3	WRF_PADRV_VBAT_VDD3P3_CORE0	PWR	CORE0 PA Driver VBAT supply
T9	WRF_PADRV_VBAT_VDD3P3_CORE1	PWR	CORE1 PA Driver VBAT supply
T1	WRF_PA5G_VBAT_VDD3P3_CORE0	PWR	5 GHz CORE0 PA 3.3V VBAT supply
V10	WRF_PA5G_VBAT_VDD3P3_CORE1	PWR	5 GHz CORE1 PA 3.3V VBAT supply
R1	WRF_PA2G_VBAT_VDD3P3_CORE0	PWR	2 GHz CORE0 PA 3.3V VBAT supply
V9	WRF_PA2G_VBAT_VDD3P3_CORE1	PWR	2 GHz CORE1 PA 3.3V VBAT supply
T5	WRF_MMD_VDD1P2	PWR	1.2V supply
T4	WRF_PFD_VDD1P2	PWR	1.2V supply
<b>Miscellaneous Supplies</b>			
–	OTP_VDD33	PWR	OTP 3.3V supply
B7, D4, E9, G10, J8, J12, L10, M7	VDDC	PWR	1.2V core supply for WLAN
E10	VDDIO	PWR	1.8V–3.3V supply for WLAN. Must be directly connected to PMU_VDDIO and BT_VDDIO on the PCB.
E4, H3, M5	BT_VDDC	PWR	1.2V core supply for BT
–	VDDIO_PMU	PWR	1.8V–3.3V supply for PMU controls. Must be directly connected to VDDIO and BT_VDDIO on the PCB.
E8	VDDIO_SD	PWR	1.8V–3.3V supply for SDIO pads and PCIe out-of-band signals.
H11	VDDIO_RF	PWR	IO supply for RF switch control pads (3.3V)
H7	AVDD_BBPLL	PWR	Baseband PLL supply
B3	PCIE_PLL_AVDD1P2	PWR	1.2V supply for PCIe PLL. (This pin should be left unconnected (NC) for SDIO operation.)
B2	PCIE_RXTX_AVDD1P2	PWR	1.2V supply for PCIe TX and RX. (This pin should be left unconnected (NC) for SDIO operation.)
<b>Ground</b>			
U6	WRF_VCO_GND1P2	GND	VCO/LOGEN ground
P4	WRF_AFE_GND1P2_CORE0	GND	CORE0 AFE ground
R8	WRF_AFE_GND1P2_CORE1	GND	CORE1 AFE ground
V4	WRF_BUCK_GND1P5_CORE0	GND	Internal capacitor-less CORE0 LDO ground
R12	WRF_BUCK_GND1P5_CORE1	GND	Internal capacitor-less CORE1 LDO ground
N2	WRF_LNA_2G_GND1P2_CORE0	GND	2 GHz internal CORE0 LNA ground



**Table 23. WLBGA Signal Descriptions (Cont.)**

Ball#	Signal Name	Type	Description
U7	WRF_LNA_2G_GND1P2_CORE1	GND	2 GHz internal CORE1 LNA ground
V2	WRF_LNA_5G_GND1P2_CORE0	GND	5 GHz internal CORE0 LNA ground
U12	WRF_LNA_5G_GND1P2_CORE1	GND	5 GHz internal CORE1 LNA ground
P3	WRF_TX_GND1P2_CORE0	GND	TX CORE0 ground
T8	WRF_TX_GND1P2_CORE1	GND	TX CORE1 ground
T3	WRF_PADRV_VBAT_GND3P3_CORE0	GND	PAD CORE0 ground
T10	WRF_PADRV_VBAT_GND3P3_CORE1	GND	PAD CORE1 ground
N11	WRF_XTAL_GND1P2	GND	XTAL ground
N3	WRF_RX2G_GND1P2_CORE0	GND	RX 2GHz CORE0 ground
T7	WRF_RX2G_GND1P2_CORE1	GND	RX 2GHz CORE1 ground
V3	WRF_RX5G_GND1P2_CORE0	GND	RX 5GHz CORE0 ground
T12	WRF_RX5G_GND1P2_CORE1	GND	RX 5GHz CORE1 ground
R6	WRF_LOGEN_GND1P2	GND	LOGEN ground
R5	WRF_LOGENG_GND1P2	GND	LOGEN ground
T2, U2	WRF_PA5G_VBAT_GND3P3_CORE0	GND	5 GHz PA CORE0 ground
U10, U11	WRF_PA5G_VBAT_GND3P3_CORE1	GND	5 GHz PA CORE1 ground
P2, R2	WRF_PA2G_VBAT_GND3P3_CORE0	GND	2 GHz PA CORE0 ground
U8, U9	WRF_PA2G_VBAT_GND3P3_CORE1	GND	2 GHz PA CORE1 ground
T6	WRF_MMD_GND1P2	GND	Ground
V5	WRF_CP_GND1P2	GND	Ground
U5	WRF_PFD_GND1P2	GND	Ground
C10, D3, D6, G4, G8, G12, L7, L11, M4	VSSC	GND	Core ground for WLAN and BT
A12	SR_PVSS	GND	Power ground
B10	PMU_AVSS	GND	Quiet ground
L2	BT_PAVSS	GND	Bluetooth PA ground
M3	BT_IFVSS	GND	Bluetooth IF block ground
L3	BT_PLLVSS	GND	Bluetooth PLL ground
J2	BT_VCOVSS	GND	Bluetooth VCO ground
G2	FM_VCOVSS	GND	FM VCO ground
H2	FM_LNAVSS	GND	FM LNA ground
G3	FM_PLLVSS	GND	FM PLL ground
F2	FM_AUDIOVSS	GND	FM AUDIO ground
G7	AVSS_BBPLL	GND	Baseband PLL ground
–	PCIE_AVSS	GND	PCie ground
B4	PCIE_RXTX_AVSS	GND	PCie ground
B5	PCIE_PLL_AVSS	GND	PCie ground
–	RGND	GND	Ground

**Table 23. WLBGA Signal Descriptions (Cont.)**

Ball#	Signal Name	Type	Description
–	BTRGND	GND	Ground
<b>No Connect</b>			
B6, C6, C7	NC	NC	No connect. Leave floating.

### 13.4 WLAN/BT GPIO Signals and Strapping Options

The pins listed in [Table 24](#) and [Table 25](#) are sampled at power-on reset (POR) to determine the various operating modes. Sampling occurs a few milliseconds after an internal POR or deassertion of the external POR. After the POR, each pin assumes the GPIO or alternative function specified in the signal descriptions table. Each strapping option pin has an internal pull-up (PU) or pull-down (PD) resistor that determines the default mode. To change the mode, connect an external PU resistor to VDDIO or a PD resistor to GND, using a 10 kΩ resistor or less.

**Note:** Refer to the reference board schematics for more information.

**Table 24. WLAN GPIO Functions and Strapping Options**

Pin Name	Default Function	Description
GPIO_4	0	1: SPROM is present 0: SPROM is absent (default). Applicable in PCIe Host mode. In SDIO Host mode, sdioPadVddio is 3.3V while set to 1, and 1.8V while set to 0.
GPIO_[10, 9, 8]	[0,0,0]	Host interface selection: see <a href="#">Table 26</a> .
GPIO_12	1	1 = HTAvailable (default) 0 = ResourceModelnit is ALPAvailable. On PCBs, use a pull-down and tie to ALP clock mode.

**Table 25. BT GPIO Functions and Strapping Options**

Pin Name	Default Function	Description
BT_GPIO4	0	1: BT Serial Flash is present. 0: BT Serial Flash is absent (default)

**Table 26. GPIO\_[10, 9, 8] Host Interface Selection**

GPIO_[10, 9, 8] Bit Setting	WLAN Host Interface Mode	Bluetooth Mode
000	SDIO	BTUART or BTUSB; BT tPorts stand-alone.
010	Not used	BTUART or BTUSB; BT tPorts stand-alone
011	PCIE	BTUART or BTUSB; BT tPorts stand-alone

### 13.5 GPIO Alternative Signal Functions

**Note:** For all new designs, use GPIO\_6 for SECI\_IN instead of GPIO\_4. For existing designs, GPIO\_4 can be still used for SECI\_IN provided the strapping requirements discussed in “WLAN/BT GPIO Signals and Strapping Options” are fully satisfied.

**Table 27. GPIO Alternative Signal Functions**

Pin Names	Test Mode	FAST UART	SPROM	BSC	Miscellaneous-0 (JTAG_SEL = 1)	GCI	Miscellaneous-1	Miscellaneous-2	UART	PWDOG 10	Additional Functionality	
	Function Select											
	0	2	4	5	6	7	8	9	3			
GPIO_0	TEST_GPIO_0	FAST_UART_RX	–	BSC_CLK	–	GCI_GPIO_4	SDIO_SEP_INT	SDIO_SEP_INT_OD	UART_DBG_TX	PWDOG_GPIO_0	WL_HOST_WAKE	
GPIO_1	TEST_GPIO_1	FAST_UART_TX	–	BSC_SDA	RF_DISABLE_L	GCI_GPIO_5	–	–	UART_DBG_RX	PWDOG_GPIO_1	WL_DEV_WAKE	
GPIO_2	TEST_GPIO_2	FAST_UART_CTS_IN	–	N/A	TCK	GCI_GPIO_1	–	–	–	–	–	
GPIO_3	TEST_GPIO_3	FAST_UART_RTS_OUT	–	N/A	TMS	GCI_GPIO_0	–	–	–	–	–	
GPIO_4	TEST_GPIO_4	–	–	N/A	TDI	SECI_IN <sup>a</sup>	–	–	UART_DBG_RX	–	–	
GPIO_5	TEST_GPIO_5	–	–	N/A	TDO	SECI_OUT	–	–	UART_DBG_TX	–	–	
GPIO_6	TEST_GPIO_6	–	–	N/A	TRST_L	GCI_GPIO_2	SECI_IN <sup>a</sup>	–	–	–	–	
GPIO_7	TEST_GPIO_7	FAST_UART_RTS_OUT	SPROM_CS	BSC_SDA	PMU_TEST_O	GCI_GPIO_3	–	UART_DBG_TX	–	PWDOG_GPIO_2	WL_LED (For WLBGA)	
GPIO_8	TEST_GPIO_8	FAST_UART_CTS_IN	SPROM_CLK	BSC_CLK	–	–	–	–	–	PWDOG_GPIO_3	–	
GPIO_9	TEST_GPIO_9	FAST_UART_RX	SPROM_MISO	PALDO_PU	–	SECI_OUT	PALDO_PD	–	–	PWDOG_GPIO_4	–	
GPIO_10	TEST_GPIO_10	FAST_UART_TX	SPROM_MOSI	–	–	GCI_GPIO_4	–	–	–	PWDOG_GPIO_5	–	

**Table 27. GPIO Alternative Signal Functions (Cont.)**

Pin Names	Test Mode	FAST UART	SPROM	BSC	Miscellaneous-0 (JTAG_SEL = 1)	GCI	Miscellaneous-1	Miscellaneous-2	UART	PWDOG 10	Additional Functionality	
	Function Select											
	0	2	4	5	6	7	8	9	3			
GPIO_11	TEST_GPIO_11	FAST_UART_RX	-	PALDO_PU	-	GCI_GPIO_5	PALDO_PD	-	-	-	-	
GPIO_12	TEST_GPIO_12	FAST_UART_TX	-	-	-	GCI_GPIO_1	-	-	-	-	-	
GPIO_13	TEST_GPIO_13	-	-	-	-	GCI_GPIO_0	-	-	-	-	-	
GPIO_14	TEST_GPIO_14	FAST_UART_RTS_OUT	-	-	-	GCI_GPIO_2	-	-	UART_DBG_RX	-	-	
GPIO_15	TEST_GPIO_15	FAST_UART_CTS_IN	-	-	-	GCI_GPIO_3	-	-	UART_DBG_TX	-	-	

**Note:**

- GPIO\_0 and WL\_DEV\_WAKE signals are selected by using software.
- SDIO\_PADVDDIO = 1 (not in straps table) is set to 3.3V by default for all packages.
- GPIO\_7 can be used as WL\_LED in WLPGA package.

a. For all new designs, use GPIO\_6 for SECI\_IN instead of GPIO\_4. For existing designs, GPIO\_4 can be still used for SECI\_IN provided the strapping requirements discussed in “[WLAN/ BT GPIO Signals and Strapping Options](#)” are fully satisfied.

Table 28 defines status for all CYW4356 GPIOs based on the tristate test mode.

**Table 28. GPIO Status Vs. Test Modes**

Test Mode	Function Select	Status for All GPIOs
TRISTATE_IND	12	Input disable
TRISTATE_PDN	13	Pull down
TRISTATE_PUP	14	Pull up
TRISTATE	15	Tristate

13.6 I/O States

The following notations are used in Table 29:

- I: Input signal
- O: Output signal
- I/O: Input/Output signal
- PU = Pulled up
- PD = Pulled down
- NoPull = Neither pulled up nor pulled down
- Where applicable, the default value is shown in bold brackets (for example, [default value])

Table 29. I/O States

Name	I/O	Keeper <sup>a</sup>	Active Mode	Low Power State/Sleep (All Power Present)	Power-down <sup>b</sup> (BT_REG_ON and WL_REG_ON Held Low)	Out-of-Reset; Before SW Down-load (BT_REG_ON High; WL_REG_ON High)	(WL_REG_ON High and BT_REG_ON=0) and VDDIOs Are Present	Power Rail
WL_REG_ON	I	N	I: PD Pull-down can be disabled	I: PD Pull-down can be disabled	I: PD (of 200K)	I: PD (of 200K)	I: PD (of 200K)	–
BT_REG_ON								
CLK_REQ	I/O	Y	Open drain or push-pull Programmable Active high	Open drain or push-pull Programmable Active high	High-Z, NoPull	Open drain Active high	Open drain Active high	BT_VDDIO
BT_HOST_WAKE	I/O	Y	I/O: PU, PD, NoPull Programmable	I/O: PU, PD, NoPull Programmable	High-Z, NoPull	I: PD	I: PD	
BT_DEV_WAKE								
BT_GPIO 5								
BT_GPIO 4								
BT_GPIO 2, 3						I: Floating, but input disabled		
BT_UART_CTS	I	Y	I: NoPull; PU programmable	I: NoPull	High-Z, NoPull	I: PU	I: PU	
BT_UART_RTS	O		O: NoPull	O: NoPull				
BT_UART_RXD	I		I: PU	I: NoPull				
BT_UART_TXD	O		O: NoPull	O: NoPull				
SDIO Data	I/O	N	I/O: PU (SDIO Mode)	I: PU (SDIO Mode)	High-Z, NoPull	I: PU (SDIO Mode)	I: PU (SDIO Mode)	VDDIO_S D
SDIO CMD								
SDIO_CLK								

Table 29. I/O States (Cont.)

Name	I/O	Keeper <sup>a</sup>	Active Mode	Low Power State/Sleep (All Power Present)	Power-down <sup>b</sup> (BT_REG_ON and WL_REG_ON Held Low)	Out-of-Reset; Before SW Down-load (BT_REG_ON High; WL_REG_ON High)	(WL_REG_ON High and BT_REG_ON=0) and VDDIOs Are Present	Power Rail	
BT_PCM_CLK	I/O	Y	I: NoPull <sup>c</sup>	I: NoPull <sup>c</sup>	High-Z, NoPull	I: PD	I: PD	BT_VDDIO	
BT_PCM_IN									
BT_PCM_OUT									
BT_PCM_SYNC									
BT_I2S_WS			I: NoPull <sup>d</sup>	I: NoPull <sup>d</sup>			I: PD		
BT_I2S_CLK									
BT_I2S_DI									
BT_I2S_DO									
GPIO_0	I/O	Y	I/O: PU, PD, NoPull Programmable <b>[NoPull]</b>	I/O: PU, PD, NoPull Programmable <b>[NoPull]</b>	High-Z, NoPull	I: NoPull	I: NoPull	VDDIO	
GPIO_1		Y							
GPIO_2		Y							
GPIO_3		Y							
GPIO_4		Y	I/O: PU, PD, NoPull Programmable <b>[PD]</b>	I/O: PU, PD, NoPull Programmable <b>[PD]</b>			I: PD		I: PD
GPIO_5		Y	I/O: PU, PD, NoPull Programmable <b>[PD]</b>	I/O: PU, PD, NoPull Programmable <b>[PD]</b>			I: NoPull		I: NoPull
GPIO_6		Y	I/O: PU, PD, NoPull Programmable <b>[NoPull]</b>	I/O: PU, PD, NoPull Programmable <b>[NoPull]</b>					
GPIO_7		Y							
GPIO_8		Y	I/O: PU, PD, NoPull <sup>e</sup>	I/O: PU, PD, NoPull <sup>e</sup>			I <sup>e</sup>		I <sup>e</sup>
GPIO_9		Y							
GPIO_10		Y	I/O: PU, PD, NoPull Programmable <b>[PD]</b>	I/O: PU, PD, NoPull Programmable <b>[PD]</b>			I: PD		I: PD
GPIO_11		Y	I/O: PU, PD, NoPull Programmable <b>[NoPull]</b>	I/O: PU, PD, NoPull Programmable <b>[NoPull]</b>			I: NoPull		I: NoPull
GPIO_12		Y	I/O: PU, PD, NoPull Programmable <b>[PU]</b>	I/O: PU, PD, NoPull Programmable <b>[PU]</b>			I: PU		I: PU
GPIO_13		Y	I/O: PU, PD, NoPull Programmable <b>[NoPull]</b>	I/O: PU, PD, NoPull Programmable <b>[NoPull]</b>			I: NoPull		I: NoPull
GPIO_14		Y							
GPIO_15	Y								

**Table 29. I/O States (Cont.)**

Name	I/O	Keeper <sup>a</sup>	Active Mode	Low Power State/Sleep (All Power Present)	Power-down <sup>b</sup> (BT_REG_ON and WL_REG_ON Held Low)	Out-of-Reset; Before SW Down- load (BT_REG_ON High; WL_REG_ON High)	(WL_REG_ON High and BT_REG_ON=0) and VDDIOs Are Present	Power Rail
RF_SW_C- TRL_X		Y	O: NoPull	O: NoPull		O: NoPull	: NoPull	

- a. Keeper column: N = pad has no keeper. Y = pad has a keeper. Keeper is always active except in Power-down state. If there is no keeper, and it is an input and there is Nopull, then the pad should be driven to prevent leakage due to floating pad (for example, SDIO\_CLK).
- b. In the Power-down state (xx\_REG\_ON=0): High-Z; NoPull => the pad is disabled because power is not supplied.
- c. Depending on whether the PCM interface is enabled and the configuration of PCM is in master or slave mode, it can be either input or output.
- d. Depending on whether the I<sup>2</sup>S interface is enabled and the configuration of I<sup>2</sup>S is in master or slave mode, it can be either input or output.
- e. For WLPGA these GPIOs have a PD in all states. For WLCSP these GPIOs have a PU in all states.

## 14. DC Characteristics

### 14.1 Absolute Maximum Ratings

**Caution!** The absolute maximum ratings in [Table 30](#) indicate levels where permanent damage to the device can occur, even if these limits are exceeded for only a brief duration. Functional operation is not guaranteed under these conditions. Operation at absolute maximum conditions for extended periods can adversely affect long-term reliability of the device.

**Table 30. Absolute Maximum Ratings**

Rating	Symbol	Value	Unit
DC supply for VBAT and PA driver supply <sup>a</sup>	VBAT	-0.5 to +6.0	V
DC supply voltage for digital I/O	VDDIO	-0.5 to 3.9	V
DC supply voltage for RF switch I/Os	VDDIO_RF	-0.5 to 3.9	V
DC input supply voltage for CLDO and LNLDO	-	-0.5 to 1.575	V
DC supply voltage for RF analog	VDDRF	-0.5 to 1.32	V
DC supply voltage for core	VDDC	-0.5 to 1.32	V
WRF_TCXO_VDD	-	-0.5 to 3.63	V
Maximum undershoot voltage for I/O <sup>b</sup>	V <sub>undershoot</sub>	-0.5	V
Maximum overshoot voltage for I/O <sup>b</sup>	V <sub>overshoot</sub>	VDDIO + 0.5	V
Maximum junction temperature	T <sub>j</sub>	125	°C

a. The maximum continuous voltage is 5.25V. Voltage transients up to 6.0V for up to 10 seconds, cumulative duration over the lifetime of the device, are allowed. Voltage transients as high as 5.5V for up to 250 seconds, cumulative duration over the lifetime of the device, are allowed.

b. Duration not to exceed 25% of the duty cycle.

### 14.2 Environmental Ratings

The environmental ratings are shown in [Table 31](#).

**Table 31. Environmental Ratings**

Characteristic	Value	Units	Conditions/Comments
Ambient Temperature (T <sub>A</sub> )	-30 to +85	°C	Functional operation <sup>a</sup>
Storage Temperature	-40 to +125	°C	-
Relative Humidity	Less than 60	%	Storage
	Less than 85	%	Operation

a. Functionality is guaranteed but specifications require derating at extreme temperatures; see the specification tables for details.

### 14.3 Electrostatic Discharge Specifications

Extreme caution must be exercised to prevent electrostatic discharge (ESD) damage. Proper use of wrist and heel grounding straps to discharge static electricity is required when handling these devices. Always store the unused material in its antistatic packaging.

**Table 32. ESD Specifications**

Pin Type	Symbol	Condition	ESD Rating	Unit
ESD, handling reference: NQY00083, Section 3.4, Group D9, Table B	ESD_HAND_HBM	Human body model contact discharge per JEDEC EID/JESD22-A114	1K for WLBGA; 1.5K for WLCSP	V
CDM	ESD_HAND_CDM	Charged device model contact discharge per JEDEC EIA/JESD22-C101	300 for WLBGA; 500 for WLCSP	V



#### 14.4 Recommended Operating Conditions and DC Characteristics

**Caution!** Functional operation is not guaranteed outside of the limits shown in Table 33, and operation outside these limits for extended periods can adversely affect long-term reliability of the device.

**Table 33. Recommended Operating Conditions and DC Characteristics**

Parameter	Symbol	Value			Unit
		Minimum	Typical	Maximum	
DC supply voltage for VBAT	VBAT	3.0 <sup>a</sup>	–	5.25 <sup>b</sup>	V
DC supply voltage for core	VDD	1.14	1.2	1.26	V
DC supply voltage for RF blocks in chip	VDDRF	1.14	1.2	1.26	V
DC supply voltage for TCXO input buffer	WRF_TCXO_VDD	1.62	1.8	1.98	V
DC supply voltage for digital I/O	VDDIO, VDDIO_SD	1.62	–	3.63	V
DC supply voltage for RF switch I/Os	VDDIO_RF	3.13	3.3	3.46	V
External TSSI input	TSSI	0.15	–	0.95	V
Internal POR threshold	Vth_POR	0.4	–	0.7	V
<b>SDIO Interface I/O Pins and PCIe Out-of-band Signals PCIE_PERST_L, PCIE_PME_L, and PCIE_CLKREQ_L</b>					
For VDDIO_SD = 1.8V:					
Input high voltage	VIH	1.27	–	–	V
Input low voltage	VIL	–	–	0.58	V
Output high voltage @ 2 mA	VOH	1.40	–	–	V
Output low voltage @ 2 mA	VOL	–	–	0.45	V
For VDDIO_SD = 3.3V:					
Input high voltage	VIH	0.625 × VDDIO	–	–	V
Input low voltage	VIL	–	–	0.25 × VDDIO	V
Output high voltage @ 2 mA	VOH	0.75 × VDDIO	–	–	V
Output low voltage @ 2 mA	VOL	–	–	0.125 × VDDIO	V
<b>Other Digital I/O Pins</b>					
For VDDIO = 1.8V:					
Input high voltage	VIH	0.65 × VDDIO	–	–	V
Input low voltage	VIL	–	–	0.35 × VDDIO	V
Output high voltage @ 2 mA	VOH	VDDIO – 0.45	–	–	V
Output low voltage @ 2 mA	VOL	–	–	0.45	V
For VDDIO = 3.3V:					
Input high voltage	VIH	2.00	–	–	V
Input low voltage	VIL	–	–	0.80	V
Output high voltage @ 2 mA	VOH	VDDIO – 0.4	–	–	V
Output low Voltage @ 2 mA	VOL	–	–	0.40	V
<b>RF Switch Control Output Pins<sup>c</sup></b>					
For VDDIO_RF = 3.3V:					
Output high voltage @ 2 mA	VOH	VDDIO – 0.4	–	–	V

**Table 33. Recommended Operating Conditions and DC Characteristics (Cont.)**

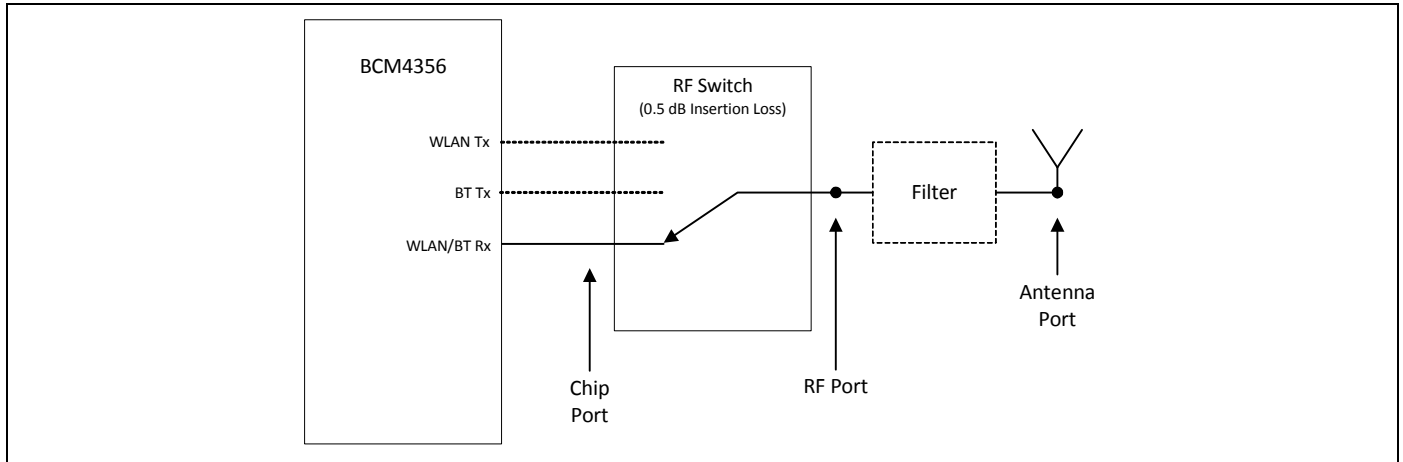
Parameter	Symbol	Value			Unit
		Minimum	Typical	Maximum	
Output low voltage @ 2 mA	VOL	–	–	0.40	V
Input capacitance	C <sub>IN</sub>	–	–	5	pF

- a. The CYW4356 is functional across this range of voltages. Optimal RF performance specified in the data sheet, however, is guaranteed only for 3.13V < VBAT < 4.8V.
- b. The maximum continuous voltage is 5.25V. Voltage transients up to 6.0V for up to 10 seconds, cumulative duration over the lifetime of the device, are allowed. Voltage transients as high as 5.5V for up to 250 seconds, cumulative duration over the lifetime of the device, are allowed.
- c. Programmable 2 mA to 16 mA drive strength. Default is 10 mA.

## 15. Bluetooth RF Specifications

Unless otherwise stated, limit values apply for the conditions specified in [Table 31](#) and [Table 33](#). Typical values apply for an ambient temperature of +25°C.

**Figure 36. RF Port Location for Bluetooth Testing**



**Note:** All Bluetooth specifications are measured at the chip port unless otherwise specified.

**Table 34. Bluetooth Receiver RF Specifications**

Parameter	Conditions	Minimum	Typical	Maximum	Unit
<b>Note:</b> The specifications in this table are measured at the chip port output unless otherwise specified.					
<b>General</b>					
Frequency range	–	2402	–	2480	MHz
RX sensitivity	GFSK, 0.1% BER, 1 Mbps	–	–93.5	–	dBm
	$\pi/4$ -DQPSK, 0.01% BER, 2 Mbps	–	–95.5	–	dBm
	8-DPSK, 0.01% BER, 3 Mbps	–	–89.5	–	dBm
Input IP3	–	–16	–	–	dBm
Maximum input at antenna	–	–	–	–20	dBm
<b>RX LO Leakage</b>					
2.4 GHz band	–	–	–90.0	–80.0	dBm
<b>Interference Performance<sup>a</sup></b>					
C/I co-channel	GFSK, 0.1% BER	–	8	11	dB
C/I 1 MHz adjacent channel	GFSK, 0.1% BER	–	–7	0	dB
C/I 2 MHz adjacent channel	GFSK, 0.1% BER	–	–38	–30	dB
C/I $\geq$ 3 MHz adjacent channel	GFSK, 0.1% BER	–	–56	–40	dB
C/I image channel	GFSK, 0.1% BER	–	–31	–9	dB
C/I 1 MHz adjacent to image channel	GFSK, 0.1% BER	–	–46	–20	dB
C/I co-channel	$\pi/4$ -DQPSK, 0.1% BER	–	9	13	dB
C/I 1 MHz adjacent channel	$\pi/4$ -DQPSK, 0.1% BER	–	–11	0	dB
C/I 2 MHz adjacent channel	$\pi/4$ -DQPSK, 0.1% BER	–	–39	–30	dB
C/I $\geq$ 3 MHz adjacent channel	$\pi/4$ -DQPSK, 0.1% BER	–	–55	–40	dB
C/I image channel	$\pi/4$ -DQPSK, 0.1% BER	–	–23	–7	dB
C/I 1 MHz adjacent to image channel	$\pi/4$ -DQPSK, 0.1% BER	–	–43	–20	dB
C/I co-channel	8-DPSK, 0.1% BER	–	17	21	dB
C/I 1 MHz adjacent channel	8-DPSK, 0.1% BER	–	–4	5	dB
C/I 2 MHz adjacent channel	8-DPSK, 0.1% BER	–	–37	–25	dB
C/I $\geq$ 3 MHz adjacent channel	8-DPSK, 0.1% BER	–	–53	–33	dB
C/I Image channel	8-DPSK, 0.1% BER	–	–16	0	dB
C/I 1 MHz adjacent to image channel	8-DPSK, 0.1% BER	–	–37	–13	dB
<b>Out-of-Band Blocking Performance (CW)</b>					
30–2000 MHz	0.1% BER	–	–10.0	–	dBm
2000–2399 MHz	0.1% BER	–	–27	–	dBm
2498–3000 MHz	0.1% BER	–	–27	–	dBm
3000 MHz–12.75 GHz	0.1% BER	–	–10.0	–	dBm
<b>Out-of-Band Blocking Performance, Modulated Interferer</b>					
GFSK (1 Mbps) <sup>b</sup>					
698–716 MHz	WCDMA	–	–13.5	–	dBm
776–849 MHz	WCDMA	–	–13.8	–	dBm
824–849 MHz	GSM850	–	–13.5	–	dBm
824–849 MHz	WCDMA	–	–14.3	–	dBm
880–915 MHz	E-GSM	–	–13.1	–	dBm
880–915 MHz	WCDMA	–	–13.1	–	dBm

**Table 34. Bluetooth Receiver RF Specifications (Cont.)**

Parameter	Conditions	Minimum	Typical	Maximum	Unit
1710–1785 MHz	GSM1800	–	–18.1	–	dBm
1710–1785 MHz	WCDMA	–	–17.4	–	dBm
1850–1910 MHz	GSM1900	–	–19.4	–	dBm
1850–1910 MHz	WCDMA	–	–18.8	–	dBm
1880–1920 MHz	TD-SCDMA	–	–19.7	–	dBm
1920–1980 MHz	WCDMA	–	–19.6	–	dBm
2010–2025 MHz	TD-SCDMA	–	–20.4	–	dBm
2500–2570 MHz	WCDMA	–	–20.4	–	dBm
2500–2570 MHz <sup>c</sup>	Band 7	–	–30.5	–	dBm
2300–2400 MHz <sup>d</sup>	Band 40	–	–34.0	–	dBm
2570–2620 MHz <sup>e</sup>	Band 38	–	–30.8	–	dBm
2545–2575 MHz <sup>f</sup>	XGP Band	–	–29.5	–	dBm
<b><math>\pi/4</math>-DPSK (2 Mbps)<sup>b</sup></b>					
698–716 MHz	WCDMA	–	–9.8	–	dBm
776–794 MHz	WCDMA	–	–9.7	–	dBm
824–849 MHz	GSM850	–	–10.7	–	dBm
824–849 MHz	WCDMA	–	–11.4	–	dBm
880–915 MHz	E-GSM	–	–10.4	–	dBm
880–915 MHz	WCDMA	–	–10.2	–	dBm
1710–1785 MHz	GSM1800	–	–15.8	–	dBm
1710–1785 MHz	WCDMA	–	–15.4	–	dBm
1850–1910 MHz	GSM1900	–	–16.6	–	dBm
1850–1910 MHz	WCDMA	–	–16.4	–	dBm
1880–1920 MHz	TD-SCDMA	–	–17.9	–	dBm
1920–1980 MHz	WCDMA	–	–16.8	–	dBm
2010–2025 MHz	TD-SCDMA	–	–18.6	–	dBm
2500–2570 MHz	WCDMA	–	–20.4	–	dBm
2500–2570 MHz <sup>c</sup>	Band 7	–	–31.9	–	dBm
2300–2400 MHz <sup>d</sup>	Band 40	–	–35.3	–	dBm
2570–2620 MHz <sup>e</sup>	Band 38	–	–31.8	–	dBm
2545–2575 MHz <sup>f</sup>	XGP Band	–	–31.1	–	dBm
<b>8-DPSK (3 Mbps)<sup>b</sup></b>					
698–716 MHz	WCDMA	–	–12.6	–	dBm
776–794 MHz	WCDMA	–	–12.6	–	dBm
824–849 MHz	GSM850	–	–12.7	–	dBm
824–849 MHz	WCDMA	–	–13.7	–	dBm
880–915 MHz	E-GSM	–	–12.8	–	dBm
880–915 MHz	WCDMA	–	–12.6	–	dBm
1710–1785 MHz	GSM1800	–	–18.1	–	dBm
1710–1785 MHz	WCDMA	–	–17.4	–	dBm
1850–1910 MHz	GSM1900	–	–19.1	–	dBm
1850–1910 MHz	WCDMA	–	–18.6	–	dBm

**Table 34. Bluetooth Receiver RF Specifications (Cont.)**

Parameter	Conditions	Minimum	Typical	Maximum	Unit
1880–1920 MHz	TD-SCDMA	–	–19.3	–	dBm
1920–1980 MHz	WCDMA	–	–18.9	–	dBm
2010–2025 MHz	TD-SCDMA	–	–20.4	–	dBm
2500–2570 MHz	WCDMA	–	–21.4	–	dBm
2500–2570 MHz <sup>c</sup>	Band 7	–	–31.0	–	dBm
2300–2400 MHz <sup>d</sup>	Band 40	–	–34.5	–	dBm
2570–2620 MHz <sup>e</sup>	Band 38	–	–31.2	–	dBm
2545–2575 MHz <sup>f</sup>	XGP Band	–	–30.0	–	dBm
<b>Spurious Emissions</b>					
30 MHz–1 GHz		–	–95	–62	dBm
1–12.75 GHz		–	–70	–47	dBm
851–894 MHz		–	–147	–	dBm/Hz
925–960 MHz		–	–147	–	dBm/Hz
1805–1880 MHz		–	–147	–	dBm/Hz
1930–1990 MHz		–	–147	–	dBm/Hz
2110–2170 MHz		–	–147	–	dBm/Hz

- a. The maximum value represents the actual Bluetooth specification required for Bluetooth qualification as defined in the version 4.1 specification.
- b. Bluetooth reference level for the wanted signal at the Bluetooth Chip port = at 3 dB desense for each data rate.
- c. Interferer: 2560 MHz, BW=10 MHz; measured at 2480 MHz.
- d. Interferer: 2360 MHz, BW=10 MHz; measured at 2402 MHz.
- e. Interferer: 2380 MHz, BW=10 MHz; measured at 2480 MHz.
- f. Interferer: 2355 MHz, BW=10 MHz; measured at 2480 MHz.

**Table 35. Bluetooth Transmitter RF Specifications**

Parameter	Conditions	Minimum	Typical	Maximum	Unit
<b>Note:</b> The specifications in this table are measured at the Chip port output unless otherwise specified.					
<b>General</b>					
Frequency range		2402	–	2480	MHz
Basic rate (GFSK) TX power at Bluetooth		–	13.0	–	dBm
QPSK TX power at Bluetooth		–	10.0	–	dBm
8PSK TX power at Bluetooth		–	10.0	–	dBm
Power control step		2	4	8	dB
Output power is with TCA and TSSI enabled.					
<b>GFSK In-Band Spurious Emissions</b>					
–20 dBc BW	–	–	0.93	1	MHz
<b>EDR In-Band Spurious Emissions</b>					
1.0 MHz <  M – N  < 1.5 MHz	M – N = the frequency range for which the spurious emission is measured relative to the transmit center frequency.	–	–38	–26.0	dBc
1.5 MHz <  M – N  < 2.5 MHz		–	–31	–20.0	dBm
M – N  ≥ 2.5 MHz <sup>a</sup>		–	–43	–40.0	dBm

**Table 35. Bluetooth Transmitter RF Specifications (Cont.)**

Parameter	Conditions	Minimum	Typical	Maximum	Unit
<b>Out-of-Band Spurious Emissions</b>					
30 MHz to 1 GHz	–	–	–	–36.0 <sup>b,c</sup>	dBm
1 GHz to 12.75 GHz	–	–	–	–30.0 <sup>b,d,e</sup>	dBm
1.8 GHz to 1.9 GHz	–	–	–	–47.0	dBm
5.15 GHz to 5.3 GHz	–	–	–	–47.0	dBm
<b>GPS Band Spurious Emissions</b>					
Spurious emissions	–	–	–103	–	dBm
<b>Out-of-Band Noise Floor<sup>f</sup></b>					
65–108 MHz	FM RX	–	–147	–	dBm/Hz
776–794 MHz	CDMA2000	–	–147	–	dBm/Hz
869–960 MHz	cdmaOne, GSM850	–	–147	–	dBm/Hz
925–960 MHz	E-GSM	–	–147	–	dBm/Hz
1570–1580 MHz	GPS	–	–146	–	dBm/Hz
1805–1880 MHz	GSM1800	–	–145	–	dBm/Hz
1930–1990 MHz	GSM1900, cdmaOne, WCDMA	–	–144	–	dBm/Hz
2110–2170 MHz	WCDMA	–	–141	–	dBm/Hz
2500–2570 MHz	Band 7	–	–140	–	dBm
2300–2400 MHz	Band 40	–	–140	–	dBm
2570–2620 MHz	Band 38	–	–140	–	dBm
2545–2575 MHz	XGP Band	–	–140	–	dBm

- a. The typical number is measured at ± 3 MHz offset.
- b. The maximum value represents the value required for Bluetooth qualification as defined in the v4.1 specification.
- c. The spurious emissions during Idle mode are the same as specified in [Table 35](#).
- d. Specified at the Bluetooth Antenna port.
- e. Meets this specification using a front-end band-pass filter.
- f. Transmitted power in cellular and FM bands at the Bluetooth Antenna port. See [Figure 36](#) for location of the port.

**Table 36. Local Oscillator Performance**

Parameter	Minimum	Typical	Maximum	Unit
<b>LO Performance</b>				
Lock time	–	72	–	µs
Initial carrier frequency tolerance	–	±25	±75	kHz
<b>Frequency Drift</b>				
DH1 packet	–	±8	±25	kHz
DH3 packet	–	±8	±40	kHz
DH5 packet	–	±8	±40	kHz
Drift rate	–	5	20	kHz/50 µs
<b>Frequency Deviation</b>				
00001111 sequence in payload <sup>a</sup>	140	155	175	kHz
10101010 sequence in payload <sup>b</sup>	115	140	–	kHz
Channel spacing	–	1	–	MHz

- a. This pattern represents an average deviation in payload.
- b. Pattern represents the maximum deviation in payload for 99.9% of all frequency deviations.

**Table 37. BLE RF Specifications**

Parameter	Conditions	Minimum	Typical	Maximum	Unit
Frequency range	–	2402		2480	MHz
RX sense <sup>a</sup>	GFSK, 0.1% BER, 1 Mbps	–	–95.5	–	dBm
TX power <sup>b</sup>	–	–	8.5	–	dBm
Mod Char: delta F1 average	–	225	255	275	kHz
Mod Char: delta F2 max. <sup>c</sup>	–	99.9	–	–	%
Mod Char: ratio	–	0.8	0.95	–	%

- a. Dirty TX is On.
- b. BLE TX power can be increased to compensate for front-end losses such as BPF, diplexer, switch, etc.). The output is capped at 12 dBm out. The BLE TX power at the antenna port cannot exceed the 10 dBm specification limit.
- c. At least 99.9% of all delta F2 max. frequency values recorded over 10 packets must be greater than 185 kHz.



## 16. FM Receiver Specifications

Unless otherwise stated, limit values apply for the conditions specified in Table 31 and Table 33. Typical values apply for an ambient temperature +25°C.

**Table 38. FM Receiver Specifications**

Parameter	Conditions <sup>a</sup>	Minimum	Typical	Maximum	Units
<b>RF Parameters</b>					
Operating frequency <sup>b</sup>	Frequencies inclusive	65	–	108	MHz
Sensitivity <sup>c</sup>	FM only SNR ≥ 26 dB	–	0	–	dBμV EMF
		–	1	–	μV EMF
		–	–6	–	dBμV
Receiver adjacent channel selectivity <sup>c,d</sup>	Measured for 30 dB SNR at the audio output. Wanted Signal: 23 dBμV EMF (14.1 μV EMF), at ± 200 kHz.	–	51	–	dB
	At ± 400 kHz	–	62	–	dB
Intermediate signal plus noise-to-noise ratio (S+N)/N, stereo <sup>c</sup>	Vin = 20 dBμV EMF (10 μV EMF)	45	53	–	dB
Intermodulation performance <sup>c,d</sup>	Blocker level increased until desired at 30 dB SNR Wanted Signal: 33 dBμV EMF (45 μV EMF) Modulated Interferer: At $f_{Wanted} + 400$ kHz and $+4$ MHz CW Interferer: At $f_{Wanted} \pm 800$ kHz and $\pm 8$ MHz	–	55	–	dBc
AM suppression, mono <sup>c</sup>	Vin = 23 dBμV EMF (14.1 μV EMF) AM at 400 Hz with $m = 0.3$ No A-weighted or any other filtering applied.	40	–	–	dB
<b>RDS</b>					
RDS sensitivity <sup>e, f</sup>	RDS deviation = 1.2 kHz	–	16	–	dBμV EMF
		–	6.3	–	μV EMF
		–	10	–	dBμV
	RDS deviation = 2 kHz	–	12	–	dBμV EMF
		–	4	–	μV EMF
		–	6	–	dBμV
RDS selectivity <sup>f</sup>	Wanted Signal: 33 dBμV EMF (45 μV EMF), 2 kHz RDS deviation Interferer: $\Delta f = 40$ kHz, $f_{mod} = 1$ kHz				
	± 200 kHz	–	49	–	dB
	± 300 kHz	–	52	–	dB
	± 400 kHz	–	52	–	dB
RF input impedance		1.5	–	–	kΩ
Antenna tuning capacitor		2.5	–	30	pF
Maximum input level <sup>c</sup>	SNR > 26 dB	–	–	113	dBμV EMF
		–	–	446	mV EMF
		–	–	107	dBμV

**Table 38. FM Receiver Specifications (Cont.)**

Parameter	Conditions <sup>a</sup>	Minimum	Typical	Maximum	Units
RF conducted emissions (measured into a 50Ω load)	Local oscillator breakthrough measured on the reference port	–	–	–55	dBm
	869–894 MHz, 925–960 MHz, 1805–1880 MHz, 1930–1990 MHz. GPS	–	–	–90	dBm
RF blocking levels at the FM antenna input 40 dB SNR (assumes a 50Ω at the radio input and excludes spurs)	GSM850, E-GSM (std), BW = 0.2 MHz, 824–849 MHz, 880–915 MHz	–	7	–	dBm
	GSM850, E-GSM (edge), BW = 0.2 MHz, 824–849 MHz, 880–915 MHz	–	–1	–	dBm
	GSM DCS 1800, PCS 1900 (std/edge), BW = 0.2 MHz, 1710–1785 MHz, 1850–1910 MHz	–	12	–	dBm
	WCDMA: II(I), III(IV, X), BW = 5 MHz, 1850–1980 MHz (1920–1980 MHz), 1710–1785 MHz (1710–1755 MHz, 1710–1770 MHz)	–	12	–	dBm
	WCDMA: V(VI), VIII, XII, XIII, XIV, BW = 5 MHz, 824–849 MHz (830–840 MHz), 880–915 MHz	–	5	–	dBm
	CDMA2000, cdmaOne, BW = 1.25 MHz, 824–849 MHz, 887–925 MHz, 776–794 MHz	–	0	–	dBm
	CDMA2000, cdmaOne, BW = 1.25 MHz, 1850–1910 MHz, 1750–1780 MHz, 1920–1980 MHz	–	12	–	dBm
	Bluetooth, BW = 1 MHz, 2402–2480 MHz	–	11	–	dBm
	IEEE 802.11g/b, BW = 20 MHz, 2400–2483.5 MHz	–	11	–	dBm
	IEEE 802.11a, BW = 20 MHz, 4915–5825 MHz	–	6	–	dBm
2500–2570 MHz	Band 7	–	11	–	dBm
2300–2400 MHz	Band 40	–	11	–	dBm
2570–2620 MHz	Band 38	–	11	–	dBm
2545–2575 MHz	XGP Band	–	11	–	dBm
<b>Tuning</b>					
Frequency step	–	10	–	–	kHz
Settling time	Single-frequency switch in any direction to a frequency within the bands 88–108 MHz or 76–90 MHz. Time measured to within 5 kHz of the final frequency.	–	150	–	μs

**Table 38. FM Receiver Specifications (Cont.)**

Parameter	Conditions <sup>a</sup>	Minimum	Typical	Maximum	Units
Search time	Total time for an automatic search to sweep from 88–108 MHz or 76–90 MHz (and reverse direction) assuming no channels are found.	–	–	8	sec
<b>General Audio</b>					
Audio output level <sup>g</sup>	–	–14.5	–	–12.5	dBFS
Maximum audio output level <sup>h</sup>	–	–	–	0	dBFS
Audio DAC output level <sup>g</sup>	–	72	–	88	mV rms
Maximum DAC audio output level <sup>h</sup>	–	–	333	–	mV rms
Audio DAC output level difference <sup>i</sup>	–	–1	–	1	dB
Left and right AC mute	FM input signal fully muted with DAC enabled	60	–	–	dB
Left and right hard mute	FM input signal fully muted with DAC disabled	80	–	–	dB
Soft mute attenuation and start level	Muting is performed dynamically proportional to the FM wanted input signal C/N. The muting characteristic is fully programmable. Refer to “Audio Features” for further details.	–	–	–	–
Maximum signal plus noise-to-noise ratio (S + N)/N, mono <sup>l</sup>	–	–	69	–	dB
Maximum signal plus noise-to-noise ratio (S + N)/N, stereo <sup>g</sup>	–	–	64	–	dB
Total harmonic distortion, mono	Vin = 66 dB $\mu$ V EMF (2 mV EMF), $\Delta$ f = 75 kHz, fmod = 400 Hz	–	–	0.8	%
	$\Delta$ f = 75 kHz, fmod = 1 kHz	–	–	0.8	%
	$\Delta$ f = 75 kHz, fmod = 3 kHz	–	–	0.8	%
	$\Delta$ f = 100 kHz, fmod = 1 kHz	–	–	1.0	%
Total harmonic distortion, stereo	Vin = 66 dB $\mu$ V EMF (2 mV EMF) $\Delta$ f = 67.5 kHz, fmod = 1 kHz, $\Delta$ f Pilot = 7.5 kHz, L = R	–	–	1.5	%
Audio spurious products <sup>i</sup>	Range from 300 Hz to 15 kHz, with respect to 1 kHz tone	–	–	–60	dBc
Audio bandwidth, upper (–3 dB point)	Vin = 66 dB $\mu$ V EMF (2 mV EMF) $\Delta$ f = 8 kHz, for 50 $\mu$ s	15	–	–	kHz
Audio bandwidth, lower (–3 dB point)	–	–	–	20	Hz
Audio in-band ripple	100 Hz to 13 kHz, Vin = 66 dB $\mu$ V EMF (2 mV EMF) $\Delta$ f = 8 kHz, for 50 $\mu$ s	–0.5	–	0.5	dB
Deemphasis time constant tolerance	With respect to 50 and 75 $\mu$ s	–	–	$\pm$ 5	%
RSSI range	With 1 dB resolution and $\pm$ 5 dB accuracy at room temp	3	–	83	dB $\mu$ V EMF
		1.41	–	14.1m	$\mu$ V EMF
		–3	–	77	dBuV
<b>Stereo Decoder</b>					
Stereo channel separation	Forced Stereo mode Vin = 66 dB $\mu$ V EMF (2 mV EMF), $\Delta$ f = 67.5 kHz, fmod = 1 kHz, $\Delta$ f Pilot = 6.75 kHz R = 0, L = 1	–	48	–	dB

**Table 38. FM Receiver Specifications (Cont.)**

Parameter	Conditions <sup>a</sup>	Minimum	Typical	Maximum	Units
Mono stereo blend and switching	Blending and switching is dynamically proportional to the FM wanted input signal C/N. The blending and switching characteristics are fully programmable. Refer to "Audio Features" on page 43 for further details.				
Pilot suppression	V <sub>in</sub> = 66 dB $\mu$ V EMF (2 mV EMF), $\Delta$ f = 75 kHz, f <sub>mod</sub> = 1 kHz	46	–	–	dB
<b>Pause detection</b>					
Audio level at which a pause is detected	Relative to 1 kHz tone, $\Delta$ f = 22.5 kHz	–	–	–	–
	Four values in 3 dB steps	–21	–	–12	dB
Audio pause duration	Four values	20	–	40	ms

- a. Following conditions are applied to all relevant tests unless otherwise indicated: Preemphasis and deemphasis of 50  $\mu$ s, R = L for mono, DAC Load  $\geq$  20 k $\Omega$ , BAF = 300 Hz to 15 kHz, and A-weighted filtering applied.
- b. Contact Cypress regarding applications that operate between 65 and 76 MHz.
- c. Wanted Signal:  $\Delta$ f = 22.5 kHz, and f<sub>mod</sub> = 1 kHz.
- d. Interferer:  $\Delta$ f = 22.5 kHz, and f<sub>mod</sub> = 1 kHz.
- e. RDS sensitivity numbers are for 87.5–108 MHz only.
- f. V<sub>in</sub> =  $\Delta$ f = 32 kHz, f<sub>mod</sub> = 1 kHz,  $\Delta$ f Pilot = 7.5 kHz, and 95% of blocks decoded with no errors after correction.
- g. V<sub>in</sub> = 66 dB $\mu$ V EMF (2 mV EMF),  $\Delta$ f = 22.5 kHz, f<sub>mod</sub> = 1 kHz, and  $\Delta$ f Pilot = 6.75 kHz.
- h. V<sub>in</sub> = 66 dB $\mu$ V EMF (2 mV EMF),  $\Delta$ f = 100 kHz, f<sub>mod</sub> = 1 kHz, and  $\Delta$ f Pilot = 6.75 kHz.
- i. V<sub>in</sub> = 66 dB $\mu$ V EMF (2 mV EMF),  $\Delta$ f = 22.5 kHz, and f<sub>mod</sub> = 1 kHz.

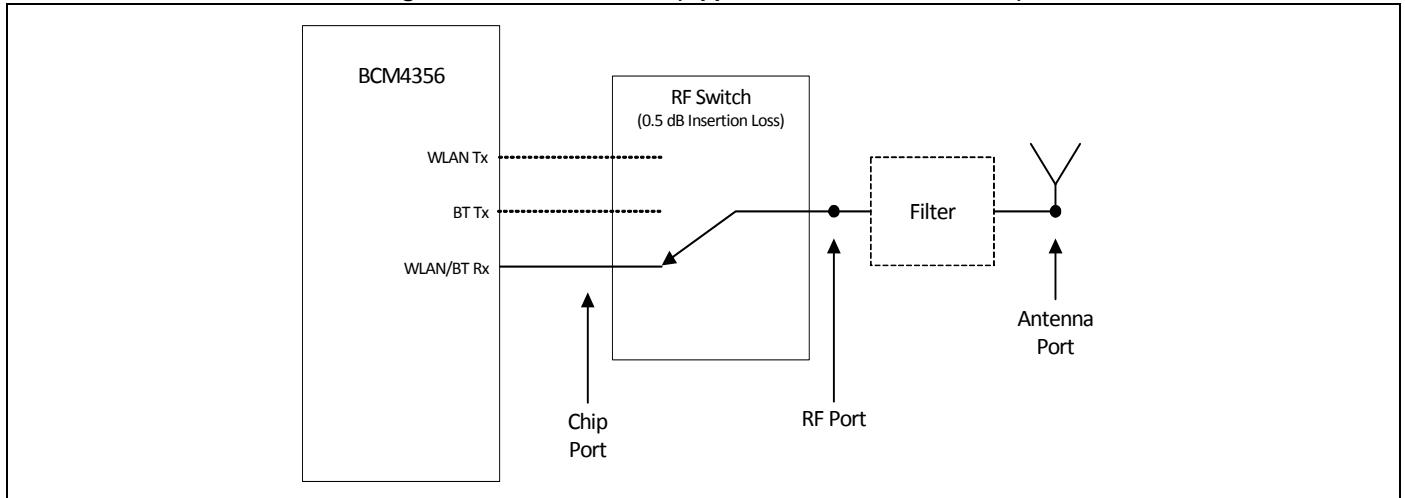
## 17. WLAN RF Specifications

### 17.1 Introduction

The CYW4356 includes an integrated dual-band direct conversion radio that supports the 2.4 GHz and the 5 GHz bands. This section describes the RF characteristics of the 2.4 GHz and 5 GHz radios.

Unless otherwise stated, limit values apply for the conditions specified in [Table 31](#) and [Table 33](#). Typical values apply for an ambient temperature +25°C.

**Figure 37. Port Locations (Applies to 2.4 GHz and 5 GHz)**



### 17.2 2.4 GHz Band General RF Specifications

**Table 39. 2.4 GHz Band General RF Specifications**

Item	Condition	Minimum	Typical	Maximum	Unit
TX/RX switch time	Including TX ramp down	–	–	5	μs
RX/TX switch time	Including TX ramp up	–	–	2	μs
Power-up and power-down ramp time	DSSS/CCK modulations	–	–	< 2	μs

**17.3 WLAN 2.4 GHz Receiver Performance Specifications**

**Note:** The values in Table 40 are specified at the RF port unless otherwise noted.

**Table 40. WLAN 2.4 GHz Receiver Performance Specifications**

Parameter	Condition/Notes	Minimum	Typical	Maximum	Unit
Frequency range	–	2400	–	2500	MHz
RX sensitivity IEEE 802.11b <sup>a</sup>	1 Mbps DSSS	–	–96.4	–	dBm
	2 Mbps DSSS	–	–94.5	–	dBm
	5.5 Mbps DSSS	–	–91.7	–	dBm
	11 Mbps DSSS	–	–89.4	–	dBm
SISO RX sensitivity IEEE 802.11g (10% PER for 1024 octet PSDU) <sup>a</sup>	6 Mbps OFDM	–	–93.5	–	dBm
	9 Mbps OFDM	–	–92.1	–	dBm
	12 Mbps OFDM	–	–91.2	–	dBm
	18 Mbps OFDM	–	–88.6	–	dBm
	24 Mbps OFDM	–	–85.3	–	dBm
	36 Mbps OFDM	–	–82	–	dBm
	48 Mbps OFDM	–	–77.3	–	dBm
	54 Mbps OFDM	–	–75.8	–	dBm
MIMO RX sensitivity IEEE 802.11g (10% PER for 1024 octet PSDU) <sup>a</sup>	6 Mbps OFDM	–	–94.5	–	dBm/core
	9 Mbps OFDM	–	–94	–	dBm/core
	12 Mbps OFDM	–	–93.2	–	dBm/core
	18 Mbps OFDM	–	–91.6	–	dBm/core
	24 Mbps OFDM	–	–88.3	–	dBm/core
	36 Mbps OFDM	–	–85	–	dBm/core
	48 Mbps OFDM	–	–80.3	–	dBm/core
	54 Mbps OFDM	–	–78.8	–	dBm/core
SISO RX sensitivity IEEE 802.11n (10% PER for 4096 octet PSDU) <sup>a,b</sup> Defined for default parameters: GF, 800 ns GI, and non-STBC.	20 MHz channel spacing for all MCS rates				
	MCS0	–	–93	–	dBm
	MCS1	–	–90.7	–	dBm
	MCS2	–	–88.2	–	dBm
	MCS3	–	–85.1	–	dBm
	MCS4	–	–81.5	–	dBm
	MCS5	–	–76.9	–	dBm
	MCS6	–	–75.3	–	dBm
MCS7	–	–73.7	–	dBm	

**Table 40. WLAN 2.4 GHz Receiver Performance Specifications (Cont.)**

Parameter	Condition/Notes	Minimum	Typical	Maximum	Unit
MIMO RX sensitivity IEEE 802.11n (10% PER for 4096 octet PSDU) <sup>a,b</sup> Defined for default parameters: GF, 800 ns GI, and non-STBC.	20 MHz channel spacing for all MCS rates				
	MCS0	–	–94.5	–	dBm/core
	MCS1	–	–93.7	–	dBm/core
	MCS2	–	–91.2	–	dBm/core
	MCS3	–	–88.1	–	dBm/core
	MCS4	–	–84.5	–	dBm/core
	MCS5	–	–79.9	–	dBm/core
	MCS6	–	–78.3	–	dBm/core
	MCS7	–	–76.7	–	dBm/core
	MCS8	–	–93	–	dBm/core
SISO RX sensitivity IEEE 802.11n (10% PER for 4096 octet PSDU) <sup>a,b</sup> Defined for default parameters: GF, 800 ns GI, and non-STBC.	40 MHz channel spacing for all MCS rates				
	MCS0	–	–90.8	–	dBm
	MCS1	–	–87.9	–	dBm
	MCS2	–	–85.5	–	dBm
	MCS3	–	–82	–	dBm
	MCS4	–	–78.9	–	dBm
	MCS5	–	–74.2	–	dBm
	MCS6	–	–72.7	–	dBm
	MCS7	–	–71.3	–	dBm
	MIMO RX sensitivity IEEE 802.11n (10% PER for 4096 octet PSDU) <sup>a,b</sup> Defined for default parameters: GF, 800 ns GI, and non-STBC.	40 MHz channel spacing for all MCS rates			
MCS0		–	–92.3	–	dBm/core
MCS1		–	–90.9	–	dBm/core
MCS2		–	–88.5	–	dBm/core
MCS3		–	–85	–	dBm/core
MCS4		–	–81.9	–	dBm/core
MCS5		–	–77.2	–	dBm/core
MCS6		–	–75.7	–	dBm/core
MCS7		–	–74.3	–	dBm/core
MCS8		–	–90.8	–	dBm/core
SISO RX sensitivity IEEE 802.11ac (10% PER for 4096 octet PSDU) <sup>a,b</sup> Defined for default parameters: GF, 800 ns GI, and non-STBC	20 MHz channel spacing for all MCS rates				
	MCS0, Nss 1	–	–92.3	–	dBm
	MCS1, Nss 1	–	–89.9	–	dBm
	MCS2, Nss 1	–	–88.1	–	dBm
	MCS3, Nss 1	–	–84.9	–	dBm
	MCS4, Nss 1	–	–81.4	–	dBm
	MCS5, Nss 1	–	–76.9	–	dBm
	MCS6, Nss 1	–	–75.3	–	dBm
	MCS7, Nss 1	–	–73.6	–	dBm
	MCS8, Nss 1	–	–69.2	–	dBm

**Table 40. WLAN 2.4 GHz Receiver Performance Specifications (Cont.)**

Parameter	Condition/Notes	Minimum	Typical	Maximum	Unit	
MIMO RX sensitivity IEEE 802.11ac (10% PER for 4096 octet PSDU) <sup>a,b</sup> Defined for default parameters: GF, 800 ns GI, and non-STBC	20 MHz channel spacing for all MCS rates					
	MCS0, Nss 1	–	–93.8	–	dBm/core	
	MCS1, Nss 1	–	–92.9	–	dBm/core	
	MCS2, Nss 1	–	–91.1	–	dBm/core	
	MCS3, Nss 1	–	–87.9	–	dBm/core	
	MCS4, Nss 1	–	–84.4	–	dBm/core	
	MCS5, Nss 1	–	–79.9	–	dBm/core	
	MCS6, Nss 1	–	–78.3	–	dBm/core	
	MCS7, Nss 1	–	–76.6	–	dBm/core	
	MCS8, Nss 1	–	–72.2	–	dBm/core	
	MCS0, Nss 2	–	–92	–	dBm/core	
MCS8, Nss 2	–	–68.1	–	dBm/core		
SISO RX sensitivity IEEE 802.11ac (10% PER for 4096 octet PSDU) <sup>a,b</sup> Defined for default parameters: GF, 800 ns GI, and non-STBC.	40 MHz channel spacing for all MCS rates					
	MCS0, Nss 1	–	–89.5	–	dBm	
	MCS1, Nss 1	–	–87	–	dBm	
	MCS2, Nss 1	–	–85.2	–	dBm	
	MCS3, Nss 1	–	–82	–	dBm	
	MCS4, Nss 1	–	–78.8	–	dBm	
	MCS5, Nss 1	–	–74.3	–	dBm	
	MCS6, Nss 1	–	–72.7	–	dBm	
	MCS7, Nss 1	–	–71.3	–	dBm	
	MCS8, Nss 1	–	–66.9	–	dBm	
	MCS9, Nss 1	–	–65.6	–	dBm	
MIMO RX sensitivity IEEE 802.11ac (10% PER for 4096 octet PSDU) <sup>a,b</sup> Defined for default parameters: GF, 800 ns GI, and non-STBC.	40 MHz channel spacing for all MCS rates					
	MCS0, Nss 1	–	–91	–	dBm/core	
	MCS1, Nss 1	–	–90	–	dBm/core	
	MCS2, Nss 1	–	–88.2	–	dBm/core	
	MCS3, Nss 1	–	–85	–	dBm/core	
	MCS4, Nss 1	–	–81.8	–	dBm/core	
	MCS5, Nss 1	–	–77.3	–	dBm/core	
	MCS6, Nss 1	–	–75.7	–	dBm/core	
	MCS7, Nss 1	–	–74.3	–	dBm/core	
	MCS8, Nss 1	–	–69.9	–	dBm/core	
	MCS9, Nss 1	–	–68.6	–	dBm/core	
	MCS0, Nss 2	–	–89	–	dBm/core	
	MCS9, Nss 2	–	–64.2	–	dBm/core	
SISO RX sensitivity IEEE 802.11ac 20/40/80 MHz channel spacing with LDPC (10% PER for 4096 octet PSDU) <sup>a,b</sup> at WLAN RF port. Defined for default parameters: GF, 800 ns GI, LDPC coding, and non-STBC.	MCS7, Nss 1	20 MHz	–	–75.4	–	dBm
	MCS8, Nss 1	20 MHz	–	–72.7	–	dBm
	MCS9, Nss 1	20 MHz	–	–69.4	–	dBm
	MCS7, Nss 1	40 MHz	–	–72.8	–	dBm
	MCS8, Nss 1	40 MHz	–	–68.5	–	dBm
	MCS9, Nss 1	40 MHz	–	–67.3	–	dBm



**Table 40. WLAN 2.4 GHz Receiver Performance Specifications (Cont.)**

Parameter	Condition/Notes		Minimum	Typical	Maximum	Unit
MIMO RX sensitivity IEEE 802.11ac 20/40/80 MHz channel spacing with LDPC (10% PER for 4096 octet PSDU) <sup>a,b</sup> at WLAN RF port. Defined for default parameters: GF, 800 ns GI, LDPC coding, and non-STBC.	MCS7, Nss 2	20 MHz	–	–74	–	dBm/core
	MCS8, Nss 2	20 MHz	–	–71.2	–	dBm/core
	MCS9, Nss 2	20 MHz	–	–68.0	–	dBm/core
	MCS7, Nss 2	40 MHz	–	–71.8	–	dBm/core
	MCS8, Nss 2	40 MHz	–	–67	–	dBm/core
	MCS9, Nss 2	40 MHz	–	–65.5	–	dBm/core
Blocking level for 3 dB RX sensitivity degradation (without external filtering) <sup>c</sup>	776–794 MHz	CDMA2000	–	–24	–	dBm
	824–849 MHz <sup>d</sup>	cdmaOne	–	–25	–	dBm
	824–849 MHz <sup>d</sup>	GSM850	–	–15	–	dBm
	880–915 MHz	E-GSM	–	–16	–	dBm
	1710–1785 MHz	GSM1800	–	–18	–	dBm
	1850–1910 MHz	GSM1800	–	–19	–	dBm
	1850–1910 MHz	cdmaOne	–	–26	–	dBm
	1850–1910 MHz	WCDMA	–	–26	–	dBm
	1920–1980 MHz	WCDMA	–	–28.5	–	dBm
	2500–2570 MHz	Band 7	–	–45	–	dBm
	2300–2400 MHz	Band 40	–	–50	–	dBm
	2570-2620 MHz	Band 38	–	–45	–	dBm
2545-2575 MHz	XGP Band	–	–45	–	dBm	
In-band static CW jammer immunity (fc - 8 MHz < fcw < + 8 MHz)	RX PER < 1%, 54 Mbps OFDM, 1000 octet PSDU for: (RxSense + 23 dB < Rxlevel < max. input level)		–80	–	–	dBm
Input In-Band IP3	Maximum LNA gain		–	–15.5	–	dBm
	Minimum LNA gain		–	–1.5	–	dBm
Maximum Receive Level @ 2.4 GHz	@ 1, 2 Mbps (8% PER, 1024 octets)		–3.5	–	–	dBm
	@ 5.5, 11 Mbps (8% PER, 1024 octets)		–9.5	–	–	dBm
	@ 6–54 Mbps (10% PER, 1024 octets)		–9.5	–	–	dBm
	@ MCS0–7 rates (10% PER, 4095 octets)		–9.5	–	–	dBm
	@ MCS8–9 rates (10% PER, 4095 octets)		–11.5	–	–	dBm
LPF 3 dB Bandwidth	–		9	–	36	MHz
Adjacent channel rejection–DSSS (Difference between interfering and desired signal at 8% PER for 1024 octet PSDU with desired signal level as specified in Condition/Notes)	Desired and interfering signal 30 MHz apart					
	1 Mbps DSSS	–74 dBm	35	–	–	dB
	2 Mbps DSSS	–74 dBm	35	–	–	dB
	Desired and interfering signal 25 MHz apart					
	5.5 Mbps DSSS	–70 dBm	35	–	–	dB
	11 Mbps DSSS	–70 dBm	35	–	–	dB

**Table 40. WLAN 2.4 GHz Receiver Performance Specifications (Cont.)**

Parameter	Condition/Notes		Minimum	Typical	Maximum	Unit
Adjacent channel rejection–OFDM (difference between interfering and desired signal (25 MHz apart) at 10% PER for 1024 octet PSDU with desired signal level as specified in Condition/Notes)	6 Mbps OFDM	–79 dBm	16	–	–	dB
	9 Mbps OFDM	–78 dBm	15	–	–	dB
	12 Mbps OFDM	–76 dBm	13	–	–	dB
	18 Mbps OFDM	–74 dBm	11	–	–	dB
	24 Mbps OFDM	–71 dBm	8	–	–	dB
	36 Mbps OFDM	–67 dBm	4	–	–	dB
	48 Mbps OFDM	–63 dBm	0	–	–	dB
	54 Mbps OFDM	–62 dBm	–1	–	–	dB
Adjacent channel rejection MCS0–9 (Difference between interfering and desired signal (25 MHz apart) at 10% PER for 4096 octet PSDU with desired signal level as specified in Condition/Notes)	MCS0	–79 dBm	16	–	–	dB
	MCS1	–76 dBm	13	–	–	dB
	MCS2	–74 dBm	11	–	–	dB
	MCS3	–71 dBm	8	–	–	dB
	MCS4	–67 dBm	4	–	–	dB
	MCS5	–63 dBm	0	–	–	dB
	MCS6	–62 dBm	–1	–	–	dB
	MCS7	–61 dBm	–2	–	–	dB
	MCS8	–59 dBm	–4	–	–	dB
	MCS9	–57 dBm	–6	–	–	dB
IEEE 802.11ac Adjacent channel rejection MCS0–9 (Difference between interfering and desired signal at 10% PER for 4096 octet PSDU with desired signal level as specified in Condition/Notes)	MCS0	–82 dBm	–	–	–	dB
	MCS1	–80 dBm	–	–	–	dB
	MCS2	–77 dBm	–	–	–	dB
	MCS3	–74 dBm	–	–	–	dB
	MCS4	–70 dBm	–	–	–	dB
	MCS5	–66 dBm	–	–	–	dB
	MCS6	–65 dBm	–	–	–	dB
	MCS7	–64 dBm	–	–	–	dB
	MCS8	–59 dBm	–	–	–	dB
	MCS9	–57 dBm	–	–	–	dB

**Table 40. WLAN 2.4 GHz Receiver Performance Specifications (Cont.)**

Parameter	Condition/Notes		Minimum	Typical	Maximum	Unit
Maximum receiver gain	–	–	–	95	–	dB
Gain control step	–	–	–	3	–	dB
RSSI accuracy <sup>e</sup>	Range –90 dBm to –30 dBm		–5	–	5	dB
	Range above –30 dBm		–8	–	8	dB
Return loss	Zo = 50Ω, across the dynamic range		10	11.5	13	dB
Receiver cascaded noise figure	At maximum gain		–	4	–	dB
General spurs	1–18 GHz		–	–	–60	dBm/MHz

- a. Derate by 1.5 dB for –30°C to –10°C and 55°C to 85°C.
- b. Sensitivity degradations for alternate settings in MCS modes. MM: 0.5 dB drop, and SGI: 2 dB drop.
- c. The cellular standard listed for each band indicates the type of modulation used to generate the interfering signal in that band for the purpose of this test. It is not intended to indicate any specific usage of each band in any specific country.
- d. The blocking levels are valid for channels 1 to 11. (For higher channels, the performance may be lower due to third harmonic signals (3 × 824 MHz) falling within band.)
- e. The minimum and maximum values shown have a 95% confidence level.

**17.4 WLAN 2.4 GHz Transmitter Performance Specifications**

**Note:** The values in [Table 41](#) are specified at the RF port unless otherwise noted.

**Table 41. WLAN 2.4 GHz Transmitter Performance Specifications**

Parameter	Condition/Notes		Min.	Typ.	Max.	Unit
Frequency range	–		2400	–	2500	MHz
Transmitted power in cellular and FM bands (at 18 dBm, 100% duty cycle, 1 Mbps CCK) <sup>a</sup>	76–108 MHz	FM RX	–	–149	–	dBm/Hz
	776–794 MHz	–	–	–162	–	dBm/Hz
	869–960 MHz	cdmaOne, GSM850	–	–162	–	dBm/Hz
	925–960 MHz	E-GSM	–	–162	–	dBm/Hz
	1570–1580 MHz	GPS	–	–152	–	dBm/Hz
	1805–1880 MHz	GSM1800	–	–142	–	dBm/Hz
	1930–1990 MHz	GSM1900, cdmaOne, cdmaOne	–	–143	–	dBm/Hz
	2110–2170 MHz	WCDMA	–	–128	–	dBm/Hz
	2500–2570 MHz	Band 7	–	–92	–	dBm/Hz
	2300–2400 MHz	Band 40	–	–95	–	dBm/Hz
	2570–2620 MHz	Band 38	–	–110	–	dBm/Hz
	2545–2575 MHz	XGP Band	–	–110	–	dBm/Hz
Harmonic level (at 18 dBm with 100% duty cycle)	4.8–5.0 GHz	2nd harmonic	–	–18	–	dBm/MHz
	7.2–7.5 GHz	3rd harmonic	–	–20	–	dBm/MHz
General spurs (at 18 dBm with 100% duty cycle)	1–18 GHz		–	–	–60	dBm/MHz

**Table 41. WLAN 2.4 GHz Transmitter Performance Specifications (Cont.)**

Parameter	Condition/Notes		Min.	Typ.	Max.	Unit
<b>EVM Does Not Exceed</b>						
TX power at RF port for highest power level setting at 25°C with spectral mask and EVM compliance <sup>b</sup>	802.11b (DSSS/CCK)	-9 dB	18	19.5	-	dBm
	OFDM, BPSK	-8 dB	18	19	-	dBm
	OFDM, QPSK	-13 dB	18	19	-	dBm
	OFDM, 16-QAM	-19 dB	16.5	18	-	dBm
	OFDM, 64-QAM (R = 3/4)	-25 dB	15.5	17	-	dBm
	OFDM, 64-QAM (R = 5/6)	-28 dB	14.5	16	-	dBm
	OFDM, 256-QAM (R = 3/4, VHT20)	-30 dB	13.5	15	-	dBm
	OFDM, 256-QAM (R = 5/6, VHT20)	-32 dB	12	13.5	-	dBm
Phase noise	37.4 MHz Crystal, Integrated from 10 kHz to 10 MHz		-	0.45	-	Degrees
TX power control dynamic range	-		10	-	-	dB
Closed-loop TX power variation at highest power level setting	Across full temperature and voltage range. Applies across 10 dBm to 20 dBm output power range.		-	-	±1.5	dB
Carrier suppression	-		15	-	-	dBc
Gain control step	-		-	0.25	-	dB
Return loss at chip port TX	Zo = 50Ω		-	6	-	dB

a. The cellular standards listed only indicate the typical usages of that band in some countries; other standards may also be used within those bands.

b. Derate by 1.5 dB for -30°C to -10°C and 55°C to 85°C, or supply voltages lower than 3.0V. Derate by 3.0 dB for supply voltages of lower than 2.7V, or supply voltages lower than 3.0V at -30°C to -10°C and 55°C to 85°C.

**17.5 WLAN 5 GHz Receiver Performance Specifications**

**Note:** The values in Table 42 are specified at the RF port unless otherwise noted.

**Table 42. WLAN 5 GHz Receiver Performance Specifications**

Parameter	Condition/Notes	Min.	Typ.	Max.	Unit
Frequency range	–	4900	–	5845	MHz
SISO RX sensitivity IEEE 802.11a (10% PER for 1000 octet PSDU) <sup>a</sup>	6 Mbps OFDM	–	–92.5	–	dBm
	9 Mbps OFDM	–	–91.1	–	dBm
	12 Mbps OFDM	–	–90.2	–	dBm
	18 Mbps OFDM	–	–87.6	–	dBm
	24 Mbps OFDM	–	–84.3	–	dBm
	36 Mbps OFDM	–	–81	–	dBm
	48 Mbps OFDM	–	–76.3	–	dBm
	54 Mbps OFDM	–	–74.8	–	dBm
MIMO RX sensitivity IEEE 802.11a (10% PER for 1024 octet PSDU) <sup>a,b</sup>	6 Mbps OFDM	–	–93.5	–	dBm/core
	9 Mbps OFDM	–	–93	–	dBm/core
	12 Mbps OFDM	–	–92.2	–	dBm/core
	18 Mbps OFDM	–	–90.6	–	dBm/core
	24 Mbps OFDM	–	–87.3	–	dBm/core
	36 Mbps OFDM	–	–84	–	dBm/core
	48 Mbps OFDM	–	–79.3	–	dBm/core
	54 Mbps OFDM	–	–75.8	–	dBm/core
SISO RX sensitivity IEEE 802.11n (10% PER for 4096 octet PSDU) <sup>a,b</sup> Defined for default parameters: GF, 800 ns GI, and non-STBC.	20 MHz channel spacing for all MCS rates				
	MCS0	–	–92	–	dBm
	MCS1	–	–89.7	–	dBm
	MCS2	–	–87.2	–	dBm
	MCS3	–	–84.1	–	dBm
	MCS4	–	–80.5	–	dBm
	MCS5	–	–75.9	–	dBm
	MCS6	–	–74.3	–	dBm
	MCS7	–	–72.7	–	dBm
MIMO RX sensitivity IEEE 802.11n (10% PER for 4096 octet PSDU) <sup>a,b</sup> Defined for default parameters: GF, 800 ns GI, and non-STBC.	20 MHz channel spacing for all MCS rates				
	MCS0	–	–93.5	–	dBm/core
	MCS1	–	–92.7	–	dBm/core
	MCS2	–	–90.2	–	dBm/core
	MCS3	–	–87.1	–	dBm/core
	MCS4	–	–83.5	–	dBm/core
	MCS5	–	–78.9	–	dBm/core
	MCS6	–	–77.3	–	dBm/core
	MCS7	–	–75.7	–	dBm/core
	MCS8	–	–92	–	dBm/core
MCS15	–	–72.7	–	dBm/core	

**Table 42. WLAN 5 GHz Receiver Performance Specifications (Cont.)**

Parameter	Condition/Notes	Min.	Typ.	Max.	Unit
SISO RX sensitivity IEEE 802.11n (10% PER for 4096 octet PSDU) <sup>a,b</sup> Defined for default parameters: GF, 800 ns GI, and non-STBC.	40 MHz channel spacing for all MCS rates				
	MCS0	–	–89.8	–	dBm
	MCS1	–	–86.9	–	dBm
	MCS2	–	–84.5	–	dBm
	MCS3	–	–81	–	dBm
	MCS4	–	–77.9	–	dBm
	MCS5	–	–73.2	–	dBm
	MCS6	–	–71.7	–	dBm
MIMO RX sensitivity IEEE 802.11n (10% PER for 4096 octet PSDU) <sup>a,b</sup> Defined for default parameters: GF, 800 ns GI, and non-STBC.	40 MHz channel spacing for all MCS rates				
	MCS0	–	–91.3	–	dBm/core
	MCS1	–	–89.9	–	dBm/core
	MCS2	–	–87.5	–	dBm/core
	MCS3	–	–84	–	dBm/core
	MCS4	–	–80.9	–	dBm/core
	MCS5	–	–76.2	–	dBm/core
	MCS6	–	–74.7	–	dBm/core
	MCS7	–	–73.3	–	dBm/core
	MCS8	–	–89.8	–	dBm/core
MCS15	–	–70.3	–	dBm/core	
SISO RX sensitivity IEEE 802.11ac (10% PER for 4096 octet PSDU) <sup>a,b</sup> Defined for default parameters: GF, 800 ns GI, and non-STBC	20 MHz channel spacing for all MCS rates				
	MCS0, Nss 1	–	–91.3	–	dBm
	MCS1, Nss 1	–	–88.3	–	dBm
	MCS2, Nss 1	–	–86	–	dBm
	MCS3, Nss 1	–	–83	–	dBm
	MCS4, Nss 1	–	–79.4	–	dBm
	MCS5, Nss 1	–	–74.9	–	dBm
	MCS6, Nss 1	–	–73.3	–	dBm
	MCS7, Nss 1	–	–72.6	–	dBm
MCS8, Nss 1	–	–68.2	–	dBm	
MIMO RX sensitivity IEEE 802.11ac (10% PER for 4096 octet PSDU) <sup>a,b</sup> Defined for default parameters: GF, 800 ns GI, and non-STBC	20 MHz channel spacing for all MCS rates				
	MCS0, Nss 1	–	–92.8	–	dBm/core
	MCS1, Nss 1	–	–91.3	–	dBm/core
	MCS2, Nss 1	–	–89	–	dBm/core
	MCS3, Nss 1	–	–86	–	dBm/core
	MCS4, Nss 1	–	–82.4	–	dBm/core
	MCS5, Nss 1	–	–77.9	–	dBm/core
	MCS6, Nss 1	–	–76.3	–	dBm/core
	MCS7, Nss 1	–	–75.6	–	dBm/core
	MCS8, Nss 1	–	–71.2	–	dBm/core
	MCS0, Nss 2	–	–91	–	dBm/core
MCS8, Nss 2	–	–67.1	–	dBm/core	

**Table 42. WLAN 5 GHz Receiver Performance Specifications (Cont.)**

Parameter	Condition/Notes	Min.	Typ.	Max.	Unit
SISO RX sensitivity IEEE 802.11ac (10% PER for 4096 octet PSDU) <sup>a,b</sup> Defined for default parameters: GF, 800 ns GI, and non-STBC.	40 MHz channel spacing for all MCS rates				
	MCS0, Nss 1	–	–88.5	–	dBm
	MCS1, Nss 1	–	–85.5	–	dBm
	MCS2, Nss 1	–	–83.7	–	dBm
	MCS3, Nss 1	–	–80.5	–	dBm
	MCS4, Nss 1	–	–77.5	–	dBm
	MCS5, Nss 1	–	–72.5	–	dBm
	MCS6, Nss 1	–	–71.7	–	dBm
	MCS7, Nss 1	–	–70.3	–	dBm
	MCS8, Nss 1	–	–65.9	–	dBm
MCS9, Nss 1	–	–64.6	–	dBm	
MIMO RX sensitivity IEEE 802.11ac (10% PER for 4096 octet PSDU) <sup>a,b</sup> Defined for default parameters: GF, 800 ns GI, and non-STBC.	40 MHz channel spacing for all MCS rates				
	MCS0, Nss 1	–	–90	–	dBm/core
	MCS1, Nss 1	–	–88.5	–	dBm/core
	MCS2, Nss 1	–	–86.7	–	dBm/core
	MCS3, Nss 1	–	–83.5	–	dBm/core
	MCS4, Nss 1	–	–80.5	–	dBm/core
	MCS5, Nss 1	–	–75.5	–	dBm/core
	MCS6, Nss 1	–	–74.7	–	dBm/core
	MCS7, Nss 1	–	–73.3	–	dBm/core
	MCS8, Nss 1	–	–68.9	–	dBm/core
	MCS9, Nss 1	–	–67.6	–	dBm/core
	MCS0, Nss 2	–	–88	–	dBm/core
MCS9, Nss 2	–	–63.2	–	dBm/core	
SISO RX sensitivity IEEE 802.11ac (10% PER for 4096 octet PSDU) <sup>a,b</sup> Defined for default parameters: GF, 800 ns GI, and non-STBC.	80 MHz channel spacing for all MCS rates				
	MCS0, Nss 1	–	–85	–	dBm
	MCS1, Nss 1	–	–82	–	dBm
	MCS2, Nss 1	–	–80	–	dBm
	MCS3, Nss 1	–	–76.7	–	dBm
	MCS4, Nss 1	–	–73.7	–	dBm
	MCS5, Nss 1	–	–70.5	–	dBm
	MCS6, Nss 1	–	–68	–	dBm
	MCS7, Nss 1	–	–66.5	–	dBm
	MCS8, Nss 1	–	–62.3	–	dBm
MCS9, Nss 1	–	–60.5	–	dBm	

**Table 42. WLAN 5 GHz Receiver Performance Specifications (Cont.)**

Parameter	Condition/Notes		Min.	Typ.	Max.	Unit
MIMO RX sensitivity IEEE 802.11ac (10% PER for 4096 octet PSDU) <sup>a,b</sup> Defined for default parameters: GF, 800 ns GI, and non-STBC.	80 MHz channel spacing for all MCS rates					
	MCS0, Nss 1		–	–86.5	–	dBm/core
	MCS1, Nss 1		–	–85	–	dBm/core
	MCS2, Nss 1		–	–83	–	dBm/core
	MCS3, Nss 1		–	–79.7	–	dBm/core
	MCS4, Nss 1		–	–76.7	–	dBm/core
	MCS5, Nss 1		–	–73.5	–	dBm/core
	MCS6, Nss 1		–	–71	–	dBm/core
	MCS7, Nss 1		–	–69.5	–	dBm/core
	MCS8, Nss 1		–	–65.3	–	dBm/core
	MCS9, Nss 1		–	–63.5	–	dBm/core
	MCS0, Nss 2		–	–84.3	–	dBm/core
MCS9, Nss 2		–	–59.5	–	dBm/core	
SISO RX sensitivity IEEE 802.11ac 20/40/80 MHz channel spacing with LDPC (10% PER for 4096 octet PSDU) <sup>a,b</sup> at WLAN RF port. Defined for default parameters: GF, 800 ns GI, LDPC coding, and non-STBC.	MCS7, Nss 1	20 MHz	–	–74.4	–	dBm
	MCS8, Nss 1	20 MHz	–	–71.7	–	dBm
	MCS9, Nss 1	20 MHz	–	–71.4	–	dBm
	MCS7, Nss 1	40 MHz	–	–71.8	–	dBm
	MCS8, Nss 1	40 MHz	–	–67.5	–	dBm
	MCS9, Nss 1	40 MHz	–	–66.5	–	dBm
	MCS7, Nss 1	80 MHz	–	–68	–	dBm
	MCS8, Nss 1	80 MHz	–	–64.3	–	dBm
	MCS9, Nss 1	80 MHz	–	–62.5	–	dBm
MIMO RX sensitivity IEEE 802.11ac 20/40/80 MHz channel spacing with LDPC (10% PER for 4096 octet PSDU) <sup>a,b</sup> at WLAN RF port. Defined for default parameters: GF, 800 ns GI, LDPC coding, and non-STBC.	MCS7, Nss 2	20 MHz	–	–73	–	dBm/core
	MCS8, Nss 2	20 MHz	–	–70.2	–	dBm/core
	MCS9, Nss 2	20 MHz	–	–66.5	–	dBm/core
	MCS7, Nss 2	40 MHz	–	–70.8	–	dBm/core
	MCS8, Nss 2	40 MHz	–	–66	–	dBm/core
	MCS9, Nss 2	40 MHz	–	–64.7	–	dBm/core
	MCS7, Nss 2	80 MHz	–	–67	–	dBm/core
	MCS8, Nss 2	80 MHz	–	–62.8	–	dBm/core
	MCS9, Nss 2	80 MHz	–	–60.5	–	dBm/core



**Table 42. WLAN 5 GHz Receiver Performance Specifications (Cont.)**

Parameter	Condition/Notes		Min.	Typ.	Max.	Unit
Alternate adjacent channel rejection Blocking level for 3 dB RX sensitivity degradation <sup>c</sup> (without external filtering)	776–794 MHz	CDMA2000	-21	–	–	dBm
	824–849 MHz <sup>d</sup>	cdmaOne	-20	–	–	dBm
	824–849 MHz <sup>d</sup>	GSM850	-12	–	–	dBm
	880–915 MHz	E-GSM	-12	–	–	dBm
	1710–1785 MHz	GSM1800	-15	–	–	dBm
	1850–1910 MHz	GSM1800	-15	–	–	dBm
	1850–1910 MHz	cdmaOne	-20	–	–	dBm
	1850–1910 MHz	WCDMA	-21	–	–	dBm
	1920–1980 MHz	WCDMA	-21	–	–	dBm
	2500–2570 MHz	Band 7	-21	–	–	dBm
	2300–2400 MHz	Band 40	-21	–	–	dBm
	2570–2620 MHz	Band 38	-21	–	–	dBm
	2545–2575 MHz	XGP Band	-21	–	–	dBm

**Table 42. WLAN 5 GHz Receiver Performance Specifications (Cont.)**

Parameter	Condition/Notes		Min.	Typ.	Max.	Unit
Input In-Band IP3	Maximum LNA gain		–	–15.5	–	dBm
	Minimum LNA gain		–	–1.5	–	dBm
Maximum receive level @ 5.24 GHz	@ 6, 9, 12 Mbps		–9.5	–	–	dBm
	@ 18, 24, 36, 48, 54 Mbps		–14.5	–	–	dBm
LPF 3 dB bandwidth	–		9	–	36	MHz
Adjacent channel rejection (Difference between interfering and desired signal (20 MHz apart) at 10% PER for 1000 octet PSDU with desired signal level as specified in Condition/Notes)	6 Mbps OFDM	–79 dBm	16	–	–	dB
	9 Mbps OFDM	–78 dBm	15	–	–	dB
	12 Mbps OFDM	–76 dBm	13	–	–	dB
	18 Mbps OFDM	–74 dBm	11	–	–	dB
	24 Mbps OFDM	–71 dBm	8	–	–	dB
	36 Mbps OFDM	–67 dBm	4	–	–	dB
	48 Mbps OFDM	–63 dBm	0	–	–	dB
	54 Mbps OFDM	–62 dBm	–1	–	–	dB
	65 Mbps OFDM	–61 dBm	–2	–	–	dB
(Difference between interfering and desired signal (40 MHz apart) at 10% PER for 1000 <sup>e</sup> octet PSDU with desired signal level as specified in Condition/Notes)	6 Mbps OFDM	–78.5 dBm	32	–	–	dB
	9 Mbps OFDM	–77.5 dBm	31	–	–	dB
	12 Mbps OFDM	–75.5 dBm	29	–	–	dB
	18 Mbps OFDM	–73.5 dBm	27	–	–	dB
	24 Mbps OFDM	–70.5 dBm	24	–	–	dB
	36 Mbps OFDM	–66.5 dBm	20	–	–	dB
	48 Mbps OFDM	–62.5 dBm	16	–	–	dB
	54 Mbps OFDM	–61.5 dBm	15	–	–	dB
	65 Mbps OFDM	–60.5 dBm	14	–	–	dB
Maximum receiver gain	–		–	95	–	dB
Gain control step	–		–	3	–	dB
RSSI accuracy <sup>f</sup>	Range –90 dBm to –30 dBm		–5	–	5	dB
	Range above –30 dBm		–8	–	8	dB
Return loss	Zo = 50Ω, across the dynamic range		10	–	13	dB
Receiver cascaded noise figure	At maximum gain		–	5	–	dB
General spurs	1–18 GHz		–	–	–65	dBm/MHz

- a. Derate by 1.5 dB for –30°C to –10°C and 55°C to 85°C.
- b. The cellular standard listed for each band indicates the type of modulation used to generate the interfering signal in that band for the purpose of this test. It is not intended to indicate any specific usage of each band in any specific country.
- c. The cellular standard listed for each band indicates the type of modulation used to generate the interfering signal in that band for the purpose of this test. It is not intended to indicate any specific usage of each band in any specific country.
- d. The blocking levels are valid for channels 1 to 11. (For higher channels, the performance may be lower due to third harmonic signals (3 × 824 MHz) falling within band.)
- e. For 65 Mbps, the size is 4096.
- f. The minimum and maximum values shown have a 95% confidence level.

**17.6 WLAN 5 GHz Transmitter Performance Specifications**

Note: The values in Table 43 are specified at the RF port unless otherwise noted.

**Table 43. WLAN 5 GHz Transmitter Performance Specifications**

Parameter	Condition/Notes		Min.	Typ.	Max.	Unit
Frequency range	–		4900	–	5845	MHz
Transmitted power in cellular and FM bands (at 18 dBm) <sup>a</sup>	76–108 MHz	FMRX	–	–162	–	dBm/Hz
	776–794 MHz	–	–	–168	–	dBm/Hz
	869–960 MHz	cdmaOne, GSM850	–	–167	–	dBm/Hz
	1570–1580 MHz	GPS	–	–170	–	dBm/Hz
	1592–1610 MHz	GLONASS	–	–162	–	dBm/Hz
	1805–1880 MHz	GSM1800	–	–169	–	dBm/Hz
	1850–1910 MHz	GSM1900	–	–169	–	dBm/Hz
	1910–1930 MHz	Band 37	–	–168	–	dBm/Hz
	1930–1990 MHz	GSM1900, cdmaOne, WCDMA	–	–168	–	dBm/Hz
	2010–2075 MHz	TDSCDMA	–	–168	–	dBm/Hz
	2110–2170 MHz	WCDMA	–	–160	–	dBm/Hz
	2300–2370 MHz	Band 40	–	–166	–	dBm/Hz
	2370–2400 MHz	Band 40	–	–162	–	dBm/Hz
	2496–2530 MHz	Band 41	–	–165	–	dBm/Hz
2530–2560 MHz	Band 41	–	–165	–	dBm/Hz	
2570–2690 MHz	Band 41	–	–158	–	dBm/Hz	
Harmonic level (at 17 dBm)	9.8–11.570 GHz	2 <sup>nd</sup> harmonic	–	–30	–	dBm/MHz
General spurs	1–18 GHz	–	–	–	–57	dBm/MHz
TX power at RF port for highest power level setting at 25°C with spectral mask and EVM compliance <sup>b</sup>	OFDM, BPSK/QPSK	–13 dB	17.5	18.5	–	dBm
	OFDM, 16-QAM	–19 dB	16	17.5	–	dBm
	OFDM, 64-QAM	–	–	–	–	dBm
	(R = 3/4)	–25 dB	15	16.5	–	dBm
	OFDM, 64-QAM	–	–	–	–	dBm
	(R = 5/6)	–28 dB	14	15.5	–	dBm
	OFDM, 256-QAM (R = 3/4, VHT)	–30 dB	13	14.5	–	dBm
OFDM, 256-QAM (R = 5/6, VHT)	–32 dB	11	12.5	–	dBm	
Phase noise	37.4 MHz Crystal, Integrated from 10 kHz to 10 MHz		–	0.5	–	Degrees
TX power control dynamic range	–		10	–	–	dB
Closed loop TX power variation at highest power level setting	Across full-temperature and voltage range. Applies across 10 to 20 dBm output power range.		–	–	±2.0	dB
Carrier suppression	–		15	–	–	dBc
Gain control step	–		–	0.25	–	dB
Return loss	Zo = 50Ω		–	6	–	dB

a. The cellular standards listed indicate only typical usages of that band in some countries. Other standards may also be used within those bands.

b. Derate by 1.5 dB for –30°C to –10°C and 55°C to 85°C, or supply voltages lower than 3.0V. Derate by 3.0 dB for supply voltages of lower than 2.7V, or supply voltages lower than 3.0V at –30°C to –10°C and 55°C to 85°C.

## 18. Internal Regulator Electrical Specifications

Functional operation is not guaranteed outside of the specification limits provided in this section.

### 18.1 Core Buck Switching Regulator

**Table 44. Core Buck Switching Regulator (CBUCK) Specifications**

Specification	Notes	Min.	Typ.	Max.	Units
Input supply voltage (DC)	DC voltage range inclusive of disturbances.	3.0	3.6	5.25 <sup>a</sup>	V
PWM mode switching frequency	CCM, Load > 100 mA VBAT = 3.6V	2.8	4	5.2	MHz
PWM output current	–	–	–	600	mA
Output current limit	–	–	1400	–	mA
Output voltage range	Programmable, 30 mV steps Default = 1.35V	1.2	1.35	1.5	V
PWM output voltage DC accuracy	Includes load and line regulation. Forced PWM mode	–4	–	4	%
PWM ripple voltage, static	Measure with 20 MHz bandwidth limit. Static Load. Max. ripple based on VBAT = 3.6V, Vout = 1.35V, Fsw = 4 MHz, 2.2 µH inductor L > 1.05 µH, Cap + Board total-ESR < 20 mΩ, Cout > 1.9 µF, ESL < 200pH	–	7	20	mVpp
PWM mode peak efficiency	Peak Efficiency at 200 mA load	78	86	–	%
PFM mode efficiency	10 mA load current	70	81	–	%
Start-up time from power down	VIO already ON and steady. Time from REG_ON rising edge to CLDO reaching 1.2V	–	–	850	µs
External inductor	0806 size, ± 30%, 0.11 ± 25% Ohms	–	2.2	–	µH
External output capacitor	Ceramic, X5R, 0402, ESR < 30 mΩ at 4 MHz, ± 20%, 6.3V	2.0 <sup>b</sup>	4.7	10 <sup>c</sup>	µF
External input capacitor	For SR_VDDBATP5V pin, ceramic, X5R, 0603, ESR < 30 mΩ at 4 MHz, ± 20%, 6.3V, 4.7 µF	0.67 <sup>b</sup>	4.7	–	µF
Input supply voltage ramp-up time	0 to 4.3V	40	–	–	µs

a. The maximum continuous voltage is 5.25V. Voltages up to 6.0V for up to 10 seconds, cumulative duration, over the lifetime of the device are allowed. Voltages as high as 5.5V for up to 250 seconds, cumulative duration, over the lifetime of the device are allowed.

b. Minimum capacitor value refers to the residual capacitor value after taking into account the part-to-part tolerance, DC-bias, temperature, and aging.

c. Total capacitance includes those connected at the far end of the active load.

**18.2 3.3V LDO (LDO3P3)**
**Table 45. LDO3P3 Specifications**

Specification	Notes	Min.	Typ.	Max.	Units
Input supply voltage, $V_{in}$	Min. = $V_o + 0.2V = 3.5V$ dropout voltage requirement must be met under maximum load for performance specifications.	2.3	3.6	5.25 <sup>a</sup>	V
Output current	–	0.2	–	600	mA
Nominal output voltage, $V_o$	Default = 3.3V	–	3.3	–	V
Dropout voltage	At max. load.	–	–	200	mV
Output voltage DC accuracy	Includes line/load regulation.	–5	–	+5	%
Quiescent current	No load	–	100	120	μA
	Maximum load (600 mA)	–	5.8	6	mA
Leakage current	Power-Down mode, junction temperature = 85°C	–	1.5	5	μA
Line regulation	$V_{in}$ from ( $V_o + 0.2V$ ) to 4.8V, max. load	–	–	3.5	mV/V
Load regulation	Load from 1 mA to 450 mA	–	–	0.25	mV/mA
PSRR	$V_{in} \geq V_o + 0.2V$ , $V_o = 3.3V$ , $C_o = 4.7 \mu F$ , Max. load, 100 Hz to 100 kHz	20	–	–	dB
LDO turn-on time	Chip already powered up.	–	160	250	μs
External output capacitor, $C_o$	Ceramic, X5R, 0402, (ESR: 5 mΩ–240 mΩ), ± 10%, 10V	1.0 <sup>b</sup>	4.7	–	μF
External input capacitor	For SR_VDDBATA5V pin (shared with Bandgap) Ceramic, X5R, 0402, (ESR: 30m-200 mΩ), ± 10%, 10V. Not needed if sharing VBAT capacitor 4.7 μF with SR_VDDBATP5V.	–	4.7	–	μF

a. The maximum continuous voltage is 5.25V. Voltages up to 6.0V for up to 10 seconds, cumulative duration, over the lifetime of the device are allowed. Voltages as high as 5.5V for up to 250 seconds, cumulative duration, over the lifetime of the device are allowed.

b. Minimum capacitor value refers to the residual capacitor value after taking into account the part-to-part tolerance, DC-bias, temperature, and aging.

**18.3 3.3V LDO (LDO3P3\_B)**

**Table 46. LDO3P3\_B Specifications**

Specification	Notes	Min.	Typ.	Max.	Units
Input supply voltage, $V_{in}$	Min. = $V_o + 0.2V = 3.5V$ dropout voltage requirement must be met under maximum load for performance specifications.	2.3	3.6	5.25 <sup>a</sup>	V
Output current	–	0.1	–	150	mA
Nominal output voltage, $V_o$	Default = 3.3V	–	3.3	–	V
Dropout voltage	At max. load.	–	–	200	mV
Output voltage DC accuracy	Includes line/load regulation.	–5	–	+5	%
Quiescent current	No load	–	10	16	$\mu A$
Maximum load (150 mA)	–	–	1.38	1.4	mA
Leakage current	Power-Down mode, junction temperature = 85°C	–	1.5	5	$\mu A$
Line regulation	$V_{in}$ from ( $V_o + 0.2V$ ) to 4.8V, max. load	–	–	3.5	mV/V
Load regulation	Load from 1 mA to 450 mA	–	–	0.25	mV/mA
PSRR	$V_{in} \geq V_o + 0.2V$ , $V_o = 3.3V$ , $C_o = 4.7 \mu F$ , Max. load, 100 Hz to 100 kHz	20	–	–	dB
LDO turn-on time	Chip already powered up.	–	–	150	$\mu s$
External output capacitor, $C_o$	Ceramic, X5R, 0402, (ESR: 5 m $\Omega$ –240 m $\Omega$ ), $\pm 10\%$ , 10V	0.7 <sup>b</sup>	2.2	–	$\mu F$
External input capacitor	For SR_VDDBATA5V pin (shared with Bandgap) Ceramic, X5R, 0402	–	4.7	–	$\mu F$

a. The maximum continuous voltage is 5.25V. Voltages up to 6.0V for up to 10 seconds, cumulative duration, over the lifetime of the device are allowed. Voltages as high as 5.5V for up to 250 seconds, cumulative duration, over the lifetime of the device are allowed.

b. Minimum capacitor value refers to the residual capacitor value after taking into account the part-to-part tolerance, DC-bias, temperature, and aging.

**18.4 2.5V LDO (BTLDO2P5)**
**Table 47. BTLDO2P5 Specifications**

Specification	Notes	Min.	Typ.	Max.	Units
Input supply voltage	Min. = 2.5V + 0.2V = 2.7V. Dropout voltage requirement must be met under maximum load for performance specifications.	3.0	3.6	5.25 <sup>a</sup>	V
Nominal output voltage	Default = 2.5V.	–	2.5	–	V
Output voltage programmability	Range	2.2	2.5	2.8	V
	Accuracy at any step (including line/load regulation), load > 0.1 mA.	–5	–	5	%
Dropout voltage	At maximum load.	–	–	200	mV
Output current	–	0.1	–	70	mA
Quiescent current	No load.	–	8	16	μA
	Maximum load at 70 mA.	–	660	700	μA
Leakage current	Power-down mode.	–	1.5	5	μA
Line regulation	V <sub>in</sub> from (V <sub>o</sub> + 0.2V) to 4.8V, maximum load.	–	–	3.5	mV/V
Load regulation	Load from 1 mA to 70 mA, V <sub>in</sub> = 3.6V.	–	–	0.3	mV/mA
PSRR	V <sub>in</sub> ≥ V <sub>o</sub> + 0.2V, V <sub>o</sub> = 2.5V, C <sub>o</sub> = 2.2 μF, maximum load, 100 Hz to 100 kHz.	20	–	–	dB
LDO turn-on time	Chip already powered up.	–	–	150	μs
In-rush current	V <sub>in</sub> = V <sub>o</sub> + 0.15V to 4.8V, C <sub>o</sub> = 2.2 μF, No load.	–	–	250	mA
External output capacitor, C <sub>o</sub>	Ceramic, X5R, 0402, (ESR: 5–240 mΩ), ±10%, 10V	0.7 <sup>b</sup>	2.2	2.64	μF
External input capacitor	For SR_VDDBATA5V pin (shared with Bandgap) ceramic, X5R, 0402, (ESR: 30–200 mΩ), ±10%, 10V. Not needed if sharing VBAT 4.7 μF capacitor with SR_VDDBATP5V.	–	4.7	–	μF

a. The maximum continuous voltage is 5.25V. Voltages up to 6.0V for up to 10 seconds, cumulative duration, over the lifetime of the device are allowed. Voltages as high as 5.5V for up to 250 seconds, cumulative duration, over the lifetime of the device are allowed.

b. The minimum value refers to the residual capacitor value after taking into account part-to-part tolerance, DC-bias, temperature, and aging.

**18.5 CLDO**
**Table 48. CLDO Specifications**

Specification	Notes	Min.	Typ.	Max.	Units
Input supply voltage, $V_{in}$	Min. = $1.2 + 0.15V = 1.35V$ dropout voltage requirement must be met under maximum load.	1.3	1.35	1.5	V
Output current	–	0.2	–	300	mA
Output voltage, $V_o$	Programmable in 25 mV steps. Default = 1.2V	1.1	1.2	1.275	V
Dropout voltage	At max. load	–	–	150	mV
Output voltage DC accuracy	Includes line/load regulation	–4	–	+4	%
Quiescent current	No load	–	24	–	$\mu A$
	300 mA load	–	2.1	–	mA
Line Regulation	$V_{in}$ from ( $V_o + 0.15V$ ) to 1.5V, maximum load	–	–	5	mV/V
Load Regulation	Load from 1 mA to 300 mA	–	0.02	0.05	mV/mA
Leakage Current	Power down	–	–	20	$\mu A$
	Bypass mode	–	1	3	$\mu A$
PSRR	@1 kHz, $V_{in} \geq 1.35V$ , $C_o = 4.7 \mu F$	20	–	–	dB
Start-up Time of PMU	VIO up and steady. Time from the REG_ON rising edge to the CLDO reaching 1.2V.	–	–	700	$\mu s$
LDO Turn-on Time	LDO turn-on time when rest of the chip is up	–	140	180	$\mu s$
External Output Capacitor, $C_o$	Total ESR: 5 m $\Omega$ –240 m $\Omega$	1.32 <sup>a</sup>	4.7	–	$\mu F$
External Input Capacitor	Only use an external input capacitor at the VDD_LDO pin if it is not supplied from CBUCK output.	–	1	2.2	$\mu F$

a. Minimum capacitor value refers to the residual capacitor value after taking into account the part-to-part tolerance, DC-bias, temperature, and aging.



**18.6 LNLDO**
**Table 49. LNLDO Specifications**

Specification	Notes	Min.	Typ.	Max.	Units
Input supply voltage, $V_{in}$	Min. = $1.2V_o + 0.15V = 1.35V$ dropout voltage requirement must be met under maximum load.	1.3	1.35	1.5	V
Output Current	–	0.1	–	150	mA
Output Voltage, $V_o$	Programmable in 25 mV steps. Default = 1.2V	1.1	1.2	1.275	V
Dropout Voltage	At maximum load	–	–	150	mV
Output Voltage DC Accuracy	Includes line/load regulation	–4	–	+4	%
Quiescent current	No load	–	44	–	$\mu A$
	Max. load	–	970	990	$\mu A$
Line Regulation	$V_{in}$ from $(V_o + 0.1V)$ to 1.5V, max. load	–	–	5	mV/V
Load Regulation	Load from 1 mA to 150 mA	–	0.02	0.05	mV/mA
Leakage Current	Power-down	–	–	10	$\mu A$
Output Noise	@30 kHz, 60–150 mA load $C_o = 2.2 \mu F$	–	–	60	nV/rt Hz
	@100 kHz, 60–150 mA load $C_o = 2.2 \mu F$	–	–	35	nV/rt Hz
PSRR	@ 1kHz, Input > 1.35V, $C_o = 2.2 \mu F$ , $V_o = 1.2V$	20	–	–	dB
LDO Turn-on Time	LDO turn-on time when rest of chip is up	–	140	180	$\mu s$
External Output Capacitor, $C_o$	Total ESR (trace/capacitor): 5 m $\Omega$ –240 m $\Omega$	0.5 <sup>a</sup>	2.2	4.7	$\mu F$
External Input Capacitor	Only use an external input capacitor at the VDD_LDO pin if it is not supplied from CBUCK output. Total ESR (trace/capacitor): 30 m $\Omega$ –200 m $\Omega$	–	1	2.2	$\mu F$

a. Minimum capacitor value refers to the residual capacitor value after taking into account the part-to-part tolerance, DC-bias, temperature, and aging.

## 19. System Power Consumption

**Note:** Unless otherwise stated, these values apply for the conditions specified in [Table 33](#).

### 19.1 WLAN Current Consumption

The WLAN current consumption measurements are shown in [Table 50](#). All values in [Table 50](#) are with the Bluetooth core in reset (that is, Bluetooth and FM are OFF).

**Table 50. Typical WLAN Power Consumption**

Mode	Bandwidth (MHz)	Band (GHz)	Vbat = 3.6V mA	Vio = 1.8V $\mu$ A <sup>a</sup>
<b>Sleep Modes</b>				
<b>OFF</b> <sup>b</sup>	–	–	0.003	36
<b>Sleep</b> <sup>c</sup>	–	–	0.005	260
IEEE power save, DTIM 1 1 RX core <sup>d</sup>	20	2.4	1.2	260
IEEE power save, DTIM 3 1 RX core <sup>d</sup>	20	2.4	0.4	260
IEEE power save, DTIM 1 1 RX core <sup>d</sup>	20	5	1.2	260
IEEE power save, DTIM 3 1 RX core <sup>d</sup>	20	5	0.4	260
IEEE power save, DTIM 1 1 RX core <sup>d</sup>	40	5	1.5	260
IEEE power save, DTIM 3 1 RX core <sup>d</sup>	40	5	0.5	260
IEEE power save, DTIM 1 1 RX core <sup>d</sup>	80	5	2.0	260
IEEE power save, DTIM 3 1 RX core <sup>d</sup>	80	5	0.7	260
<b>Active Modes</b>				
<b>Transmit</b>				
CCK 1 chain <sup>e</sup>	20	2.4	450	60
MCS8, Nss 1, HT20, SGI <sup>f, g, h</sup>	20	2.4	330	60
MCS8, Nss 2, HT20, SGI <sup>f, g, h</sup>	20	2.4	610	60
MCS7, SGI <sup>f, g, i</sup>	20	5	310	60
MCS15, SGI <sup>f, g, i</sup>	20	5	620	60
MCS7 <sup>f, g, i</sup>	40	5	340	60
MCS9, Nss 1, SGI <sup>f, g, j</sup>	40	5	300	60
MCS9, Nss 2, SGI <sup>f, g, j</sup>	40	5	590	60
MCS9, Nss 1, SGI <sup>f, g, j</sup>	80	5	330	60
MCS9, Nss 2, SGI <sup>f, g, j</sup>	80	5	610	60
<b>Receive</b>				
1 Mbps, 1 RX core	20	2.4	65	60
1 Mbps, 2 RX cores	20	2.4	87	60
MCS7, HT20 1 RX core <sup>k</sup>	20	2.4	69	60
MCS7, HT20 2 RX cores <sup>k</sup>	20	2.4	92	60
MCS15, HT20 <sup>k</sup>	20	2.4	96	60
CRS 1 RX core <sup>l</sup>	20	2.4	66	60
CRS 2 RX cores <sup>l</sup>	20	2.4	86	60
Receive MCS7, SGI 1 RX core <sup>k</sup>	20	5	84	60
Receive MCS7, SGI 2 RX cores <sup>k</sup>	20	5	111	60
Receiver MCS15, SGI <sup>k</sup>	20	5	116	60
CRS 1 RX core <sup>l</sup>	20	5	79	60
CRS 2 RX cores <sup>l</sup>	20	5	103	60
Receive MCS 7, SGI 1 RX core <sup>k</sup>	40	5	101	60

**Table 50. Typical WLAN Power Consumption (Cont.)**

Mode	Bandwidth (MHz)	Band (GHz)	Vbat = 3.6V mA	Vio = 1.8V $\mu$ A <sup>a</sup>
Receive MCS 7, SGI 2 RX cores <sup>k</sup>	40	5	140	60
Receive MCS 15, SGI <sup>k</sup>	40	5	151	60
CRS 1 RX core <sup>l</sup>	40	5	93	60
CRS 2 RX cores <sup>l</sup>	40	5	128	60
Receive MCS9, Nss 1, SGI <sup>k</sup>	80	5	136	60
Receive MCS9, Nss 1, SGI 2 RX cores <sup>k</sup>	80	5	189	60
Receive MCS9, Nss 2, SGI <sup>k</sup>	80	5	205	60
CRS 1 RX core <sup>l</sup>	80	5	117	60
CRS 2 RX cores <sup>l</sup>	80	5	172	60

- a. Specified with all pins idle (not switching) and not driving any loads.
- b. WL\_REG\_ON and BT\_REG\_ON low.
- c. Idle, not associated, or inter-beacon.
- d. Beacon Interval = 102.4 ms. Beacon duration = 1 ms @1 Mbps. Average current over three DTIM intervals.
- e. Output power per core at RF port = 21 dBm
- f. Duty cycle is 100%.
- g. Measured using packet engine test mode.
- h. Output power per core at RF port = 17 dBm.
- i. Output power per core at RF port = 17.5 dBm.
- j. Output power per core at RF port = 14 dBm.
- k. Duty cycle is 100%. Carrier sense (CS) detect/packet receive.
- l. Carrier sense (CCA) when no carrier is present.

## 19.2 Bluetooth and FM Current Consumption

The Bluetooth, BLE, and FM current consumption measurements are shown in [Table 51](#).

**Note:**

- The WLAN core is in reset (WLAN\_REG\_ON = low) for all measurements provided in [Table 51](#).
- For FM measurements, the Bluetooth core is in Sleep mode.
- The BT current consumption numbers are measured based on GFSK TX output power = 10 dBm.

**Table 51. Bluetooth BLE and FM Current Consumption**

Operating Mode	VBAT (VBAT = 3.6V) Typical	VDDIO (VDDIO = 1.8V) Typical	Units
Sleep	13	198	μA
Standard 1.28s Inquiry Scan	0.217	0.197	mA
P and I Scan <sup>b</sup>	440	194	μA
500 ms Sniff Master	0.168	0.195	mA
500 ms Sniff Slave	0.124	0.190	mA
DM1/DH1 Master	25.3	0.024	mA
DM3/DH3 Master	30.6	0.035	mA
DM5/DH5 Master	31.4	0.037	mA
3DH5 Master	29.2	0.094	mA
SCO HV3 Master	11.45	0.089	mA
HV3 + Sniff + Scan <sup>a</sup>	11.7	0.090	mA
FMRX I <sup>2</sup> S Audio	8.0	–	mA
FMRX Analog Audio only	8.6	–	mA
FMRX I <sup>2</sup> S Audio + RDS	8.0	–	mA
FMRX Analog Audio + RDS	8.6	–	mA
BLE Scan <sup>b</sup>	244	196	μA
BLE Scan 10 ms	21.34	0.013	mA
BLE Adv—Unconnectable 1.00 sec	67	199	μA
BLE Adv—Unconnectable 1.28 sec	55	199	μA
BLE Adv—Unconnectable 2.00 sec	58	199	μA
BLE Connected 7.5 ms	3.95	0.013	mA
BLE Connected 1 sec.	57	198	μA
BLE Connected 1.28 sec.	52	197	μA

a. At maximum class 1 TX power, 500 ms sniff, four attempts (slave), P = 1.28s, and I = 2.56s.

b. No devices present. A 1.28 second interval with a scan window of 11.25 ms.

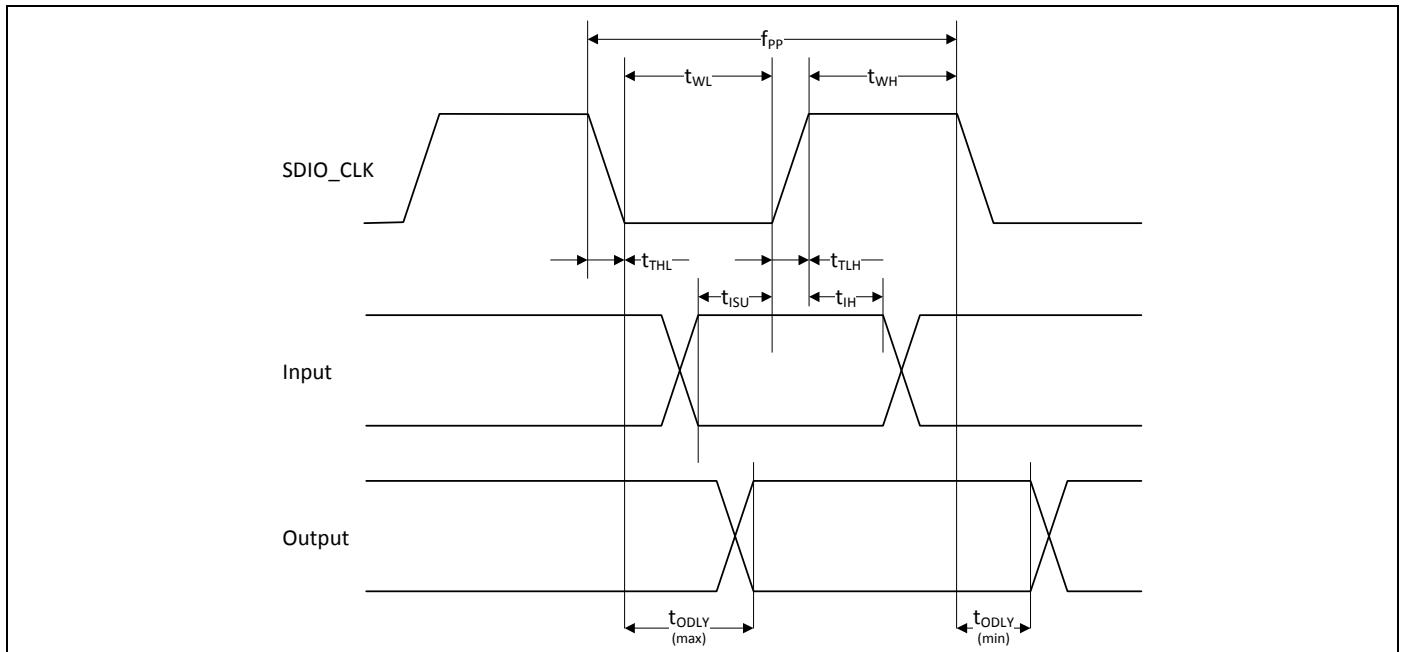
## 20. Interface Timing and AC Characteristics

### 20.1 SDIO Timing

#### 20.1.1 SDIO Default Mode Timing

SDIO default mode timing is shown by the combination of [Figure 38](#) and [Table 52](#).

**Figure 38. SDIO Bus Timing (Default Mode)**



**Table 52. SDIO Bus Timing<sup>a</sup> Parameters (Default Mode)**

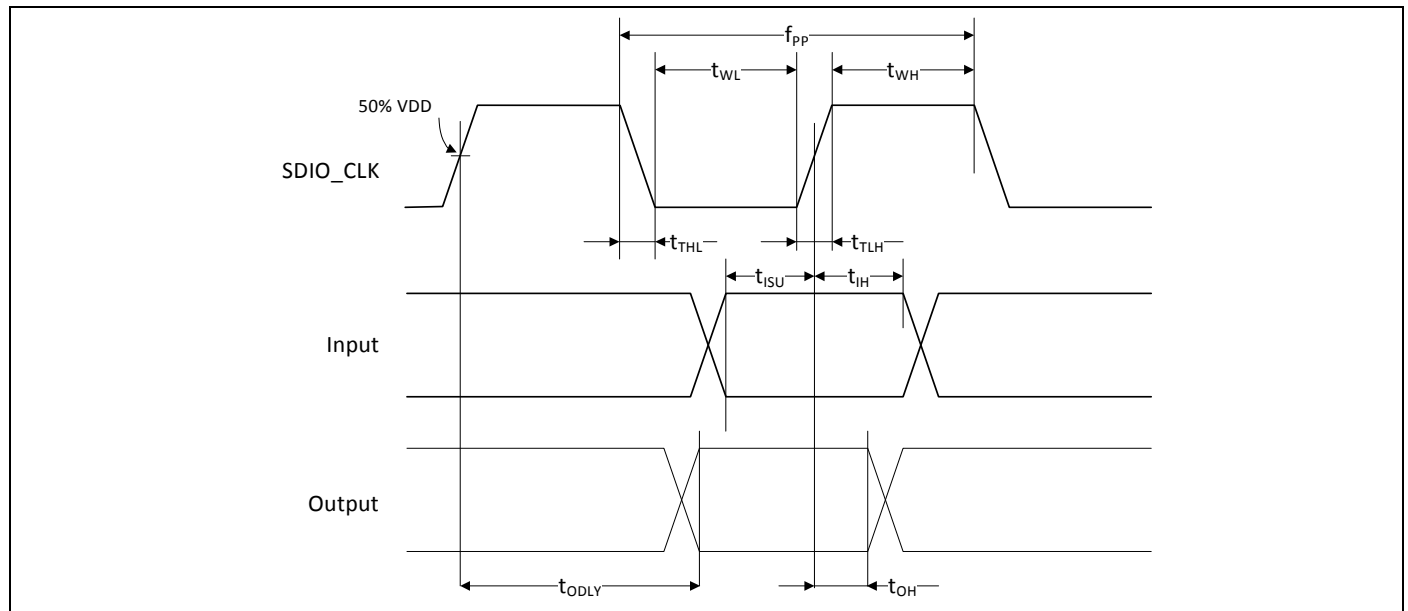
Parameter	Symbol	Minimum	Typical	Maximum	Unit
<b>SDIO CLK (All values are referred to minimum VIH and maximum VIL<sup>b</sup>)</b>					
Frequency – Data Transfer mode	fPP	0	–	25	MHz
Frequency – Identification mode	fOD	0	–	400	kHz
Clock low time	tWL	10	–	–	ns
Clock high time	tWH	10	–	–	ns
Clock rise time	tTLH	–	–	10	ns
Clock low time	tTHL	–	–	10	ns
<b>Inputs: CMD, DAT (referenced to CLK)</b>					
Input setup time	tISU	5	–	–	ns
Input hold time	tIH	5	–	–	ns
<b>Outputs: CMD, DAT (referenced to CLK)</b>					
Output delay time – Data Transfer mode	tODLY	0	–	14	ns
Output delay time – Identification mode	tODLY	0	–	50	ns

a. Timing is based on  $CL \leq 40pF$  load on CMD and Data.  
b. Min. (Vih) =  $0.7 \times VDDIO$  and max. (Vil) =  $0.2 \times VDDIO$ .

**20.1.2 SDIO High-Speed Mode Timing**

SDIO high-speed mode timing is shown by the combination of [Figure 39](#) and [Table 53](#).

**Figure 39. SDIO Bus Timing (High-Speed Mode)**



**Table 53. SDIO Bus Timing<sup>a</sup> Parameters (High-Speed Mode)**

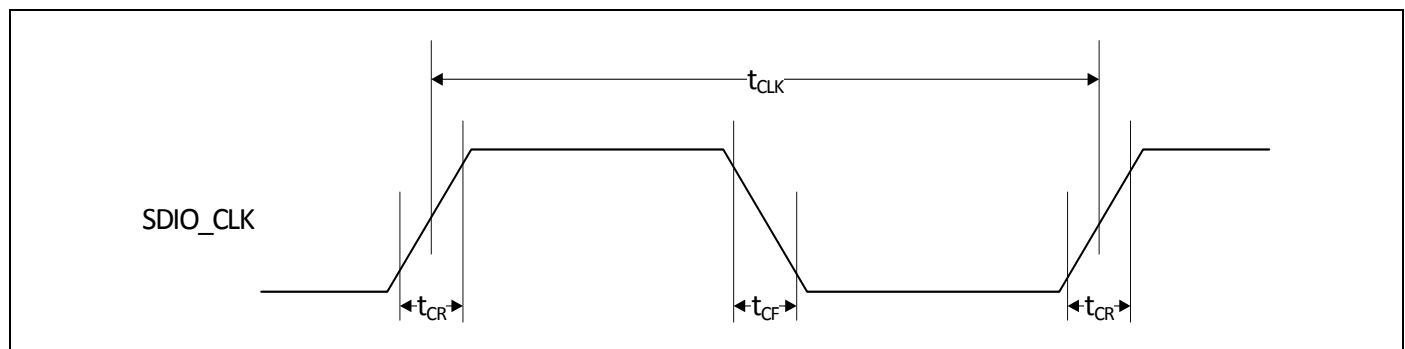
Parameter	Symbol	Minimum	Typical	Maximum	Unit
<b>SDIO CLK (all values are referred to minimum VIH and maximum VIL<sup>b</sup>)</b>					
Frequency – Data Transfer Mode	fPP	0	–	50	MHz
Frequency – Identification Mode	fOD	0	–	400	kHz
Clock low time	tWL	7	–	–	ns
Clock high time	tWH	7	–	–	ns
Clock rise time	tTLH	–	–	3	ns
Clock low time	tTHL	–	–	3	ns
<b>Inputs: CMD, DAT (referenced to CLK)</b>					
Input setup Time	tISU	6	–	–	ns
Input hold Time	tIH	2	–	–	ns
<b>Outputs: CMD, DAT (referenced to CLK)</b>					
Output delay time – Data Transfer Mode	tODLY	–	–	14	ns
Output hold time	tOH	2.5	–	–	ns
Total system capacitance (each line)	CL	–	–	40	pF

a. Timing is based on CL ≤ 40pF load on CMD and Data.

b. Min. (Vih) = 0.7 × VDDIO and max. (Vil) = 0.2 × VDDIO.

### 20.1.3 SDIO Bus Timing Specifications in SDR Modes

#### Clock Timing

**Figure 40. SDIO Clock Timing (SDR Modes)**

**Table 54. SDIO Bus Clock Timing Parameters (SDR Modes)**

Parameter	Symbol	Minimum	Maximum	Unit	Comments
–	$t_{CLK}$	40	–	ns	SDR12 mode
		20	–	ns	SDR25 mode
		10	–	ns	SDR50 mode
		4.8	–	ns	SDR104 mode
–	$t_{CR}, t_{CF}$	–	$0.2 \times t_{CLK}$	ns	$t_{CR}, t_{CF} < 2.00$ ns (max.) @100 MHz, $C_{CARD} = 10$ pF $t_{CR}, t_{CF} < 0.96$ ns (max.) @208 MHz, $C_{CARD} = 10$ pF
Clock duty	–	30	70	%	–

Device Input Timing

Figure 41. SDIO Bus Input Timing (SDR Modes)

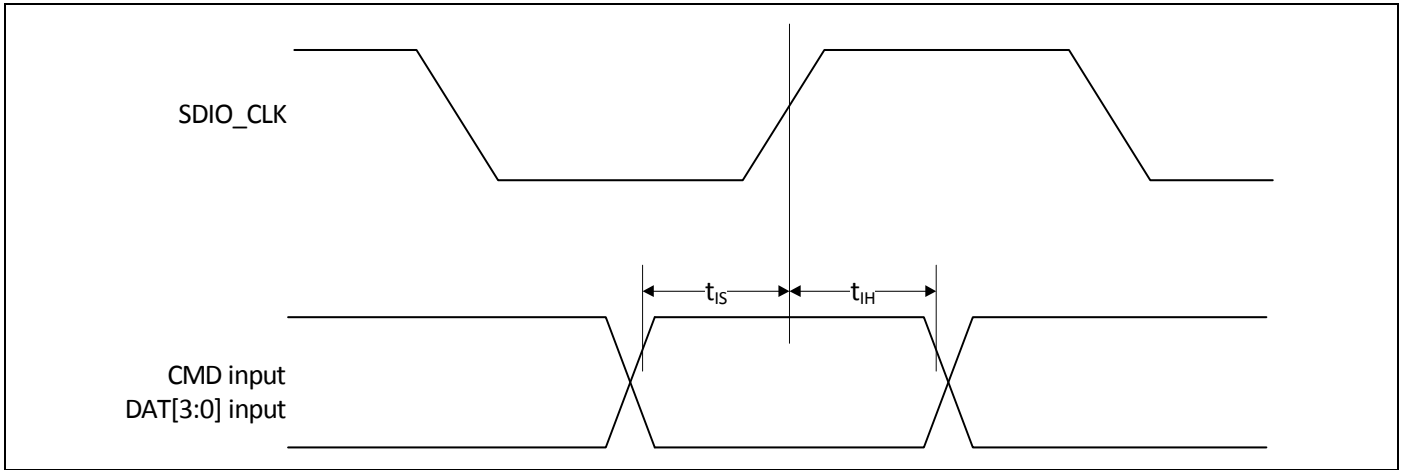


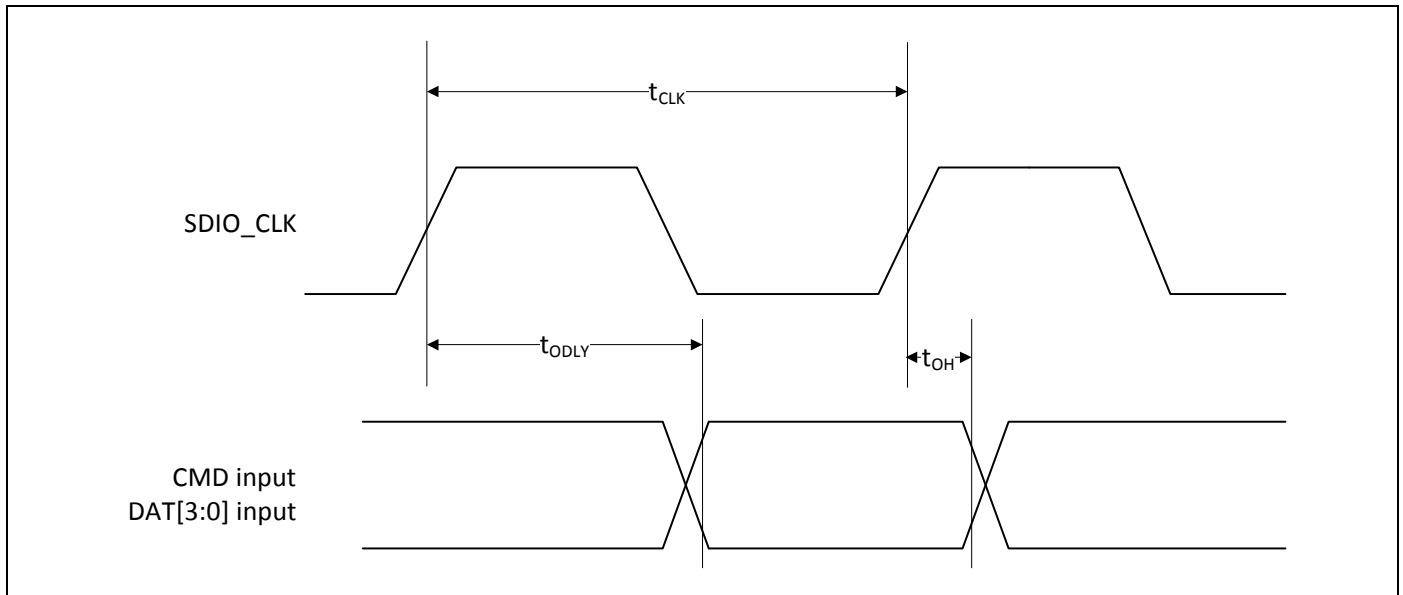
Table 55. SDIO Bus Input Timing Parameters (SDR Modes)

Symbol	Minimum	Maximum	Unit	Comments
<b>SDR104 Mode</b>				
$t_{IS}$	1.4	–	ns	$C_{CARD} = 10 \text{ pF}$ , $V_{CT} = 0.975V$
$t_{IH}$	0.80	–	ns	$C_{CARD} = 5 \text{ pF}$ , $V_{CT} = 0.975V$
<b>SDR50 Mode</b>				
$t_{IS}$	3.00	–	ns	$C_{CARD} = 10 \text{ pF}$ , $V_{CT} = 0.975V$
$t_{IH}$	0.80	–	ns	$C_{CARD} = 5 \text{ pF}$ , $V_{CT} = 0.975V$



**Device Output Timing**

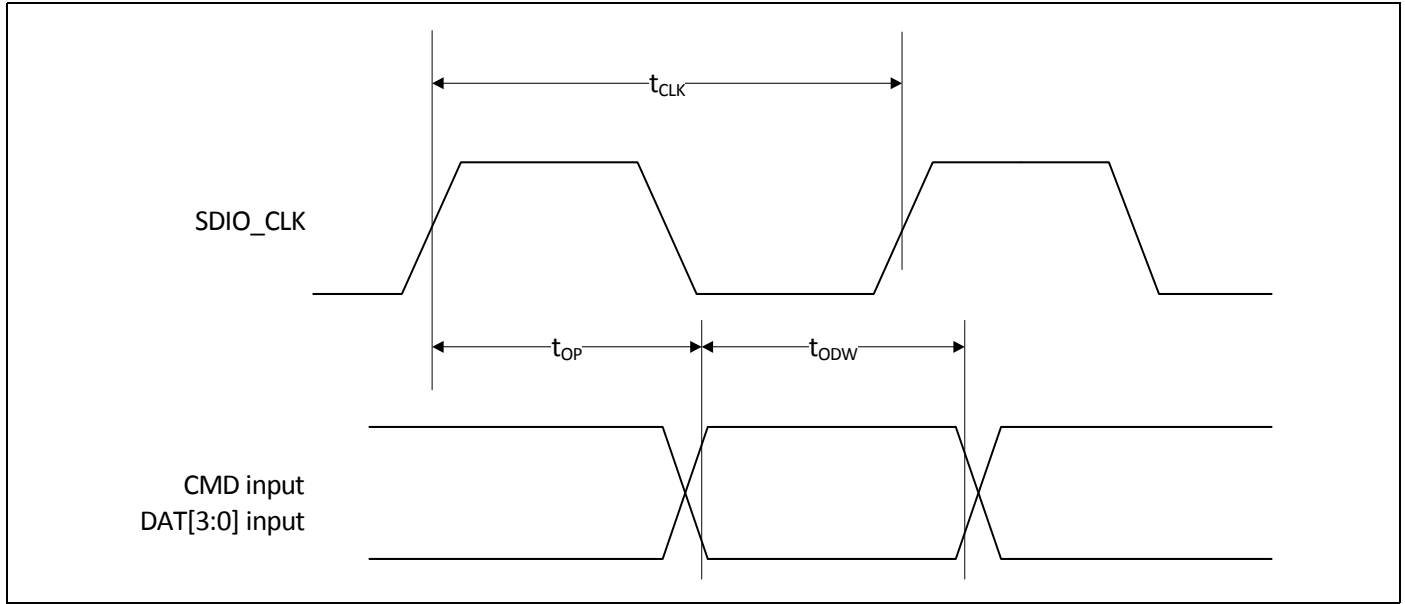
**Figure 42. SDIO Bus Output Timing (SDR Modes up to 100 MHz)**



**Table 56. SDIO Bus Output Timing Parameters (SDR Modes up to 100 MHz)**

Symbol	Minimum	Maximum	Unit	Comments
$t_{ODLY}$	–	7.5	ns	$t_{CLK} \geq 10$ ns $C_L = 30$ pF using driver type B for SDR50
$t_{ODLY}$	–	14.0	ns	$t_{CLK} \geq 20$ ns $C_L = 40$ pF using for SDR12, SDR25
$t_{OH}$	1.5	–	ns	Hold time at the $t_{ODLY}$ (min.) $C_L = 15$ pF

**Figure 43. SDIO Bus Output Timing (SDR Modes 100 MHz to 208 MHz)**

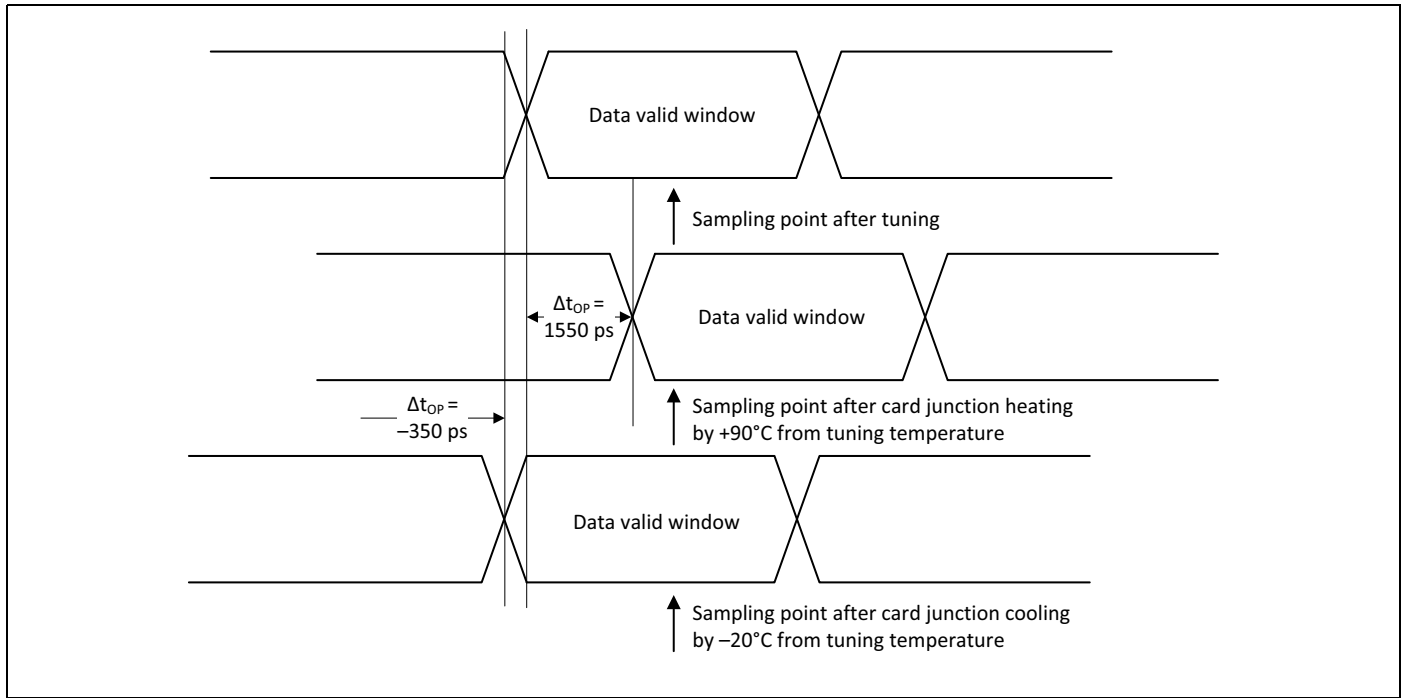


**Table 57. SDIO Bus Output Timing Parameters (SDR Modes 100 MHz to 208 MHz)**

Symbol	Minimum	Maximum	Unit	Comments
$t_{OP}$	0	2	UI	Card output phase
$\Delta t_{OP}$	-350	+1550	ps	Delay variation due to temp change after tuning
$t_{ODW}$	0.60	-	UI	$t_{ODW}=2.88$ ns @208 MHz

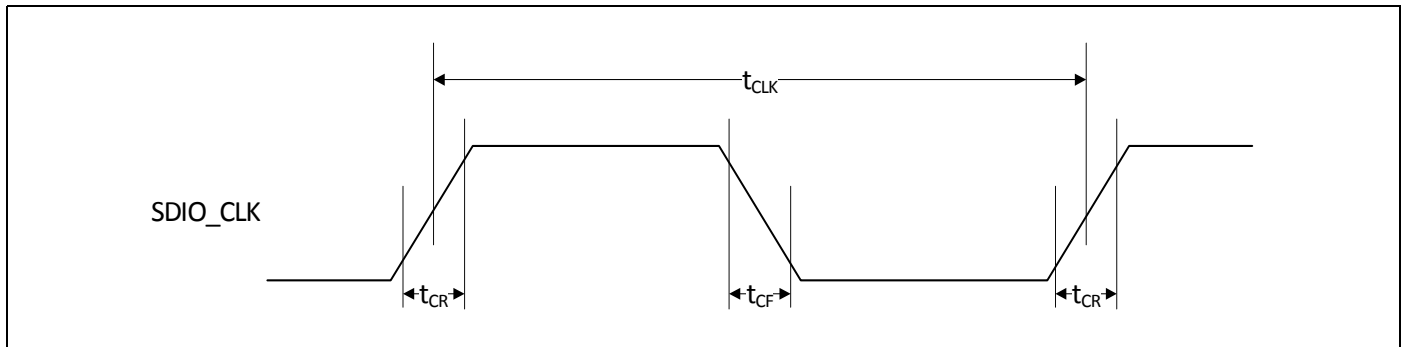
- $\Delta t_{OP} = +1550$  ps for junction temperature of  $\Delta t_{OP} = 90$  degrees during operation
- $\Delta t_{OP} = -350$  ps for junction temperature of  $\Delta t_{OP} = -20$  degrees during operation
- $\Delta t_{OP} = +2600$  ps for junction temperature of  $\Delta t_{OP} = -20$  to  $+125$  degrees during operation

**Figure 44.  $\Delta t_{OP}$  Consideration for Variable Data Window (SDR 104 Mode)**



20.1.4 SDIO Bus Timing Specifications in DDR50 Mode

**Figure 45. SDIO Clock Timing (DDR50 Mode)**



**Table 58. SDIO Bus Clock Timing Parameters (DDR50 Mode)**

Parameter	Symbol	Minimum	Maximum	Unit	Comments
–	$t_{CLK}$	20	–	ns	DDR50 mode
–	$t_{CR}, t_{CF}$	–	$0.2 \times t_{CLK}$	ns	$t_{CR}, t_{CF} < 4.00 \text{ ns (max.) @50 MHz, } C_{CARD} = 10 \text{ pF}$
Clock duty	–	45	55	%	–

Data Timing, DDR50 Mode

Figure 46. SDIO Data Timing (DDR50 Mode)

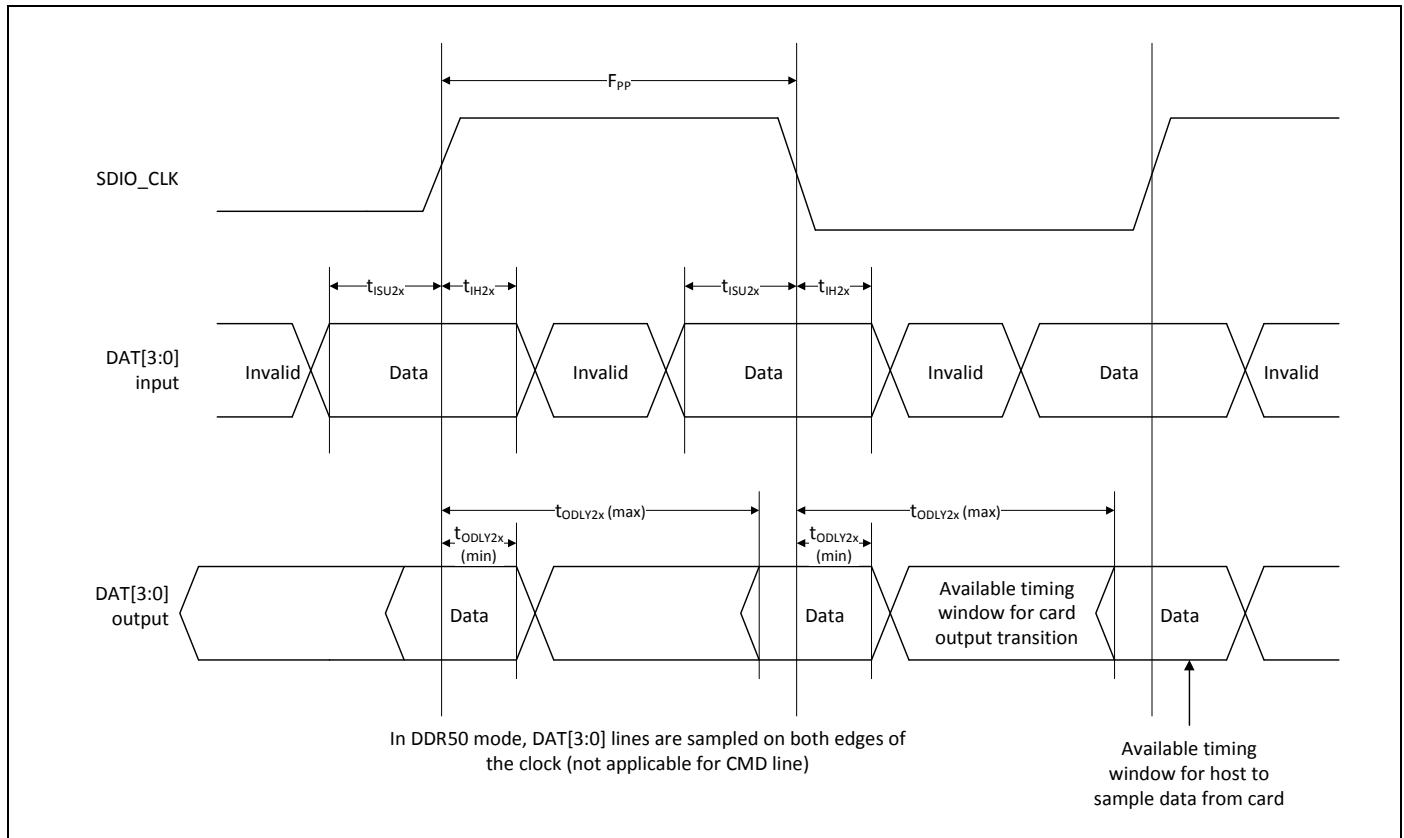


Table 59. SDIO Bus Timing Parameters (DDR50 Mode)

Parameter	Symbol	Minimum	Maximum	Unit	Comments
<b>Input CMD</b>					
Input setup time	$t_{ISU}$	6	–	ns	$C_{CARD} < 10pF$ (1 Card)
Input hold time	$t_{IH}$	0.8	–	ns	$C_{CARD} < 10pF$ (1 Card)
<b>Output CMD</b>					
Output delay time	$t_{ODLY}$	–	13.7	ns	$C_{CARD} < 30pF$ (1 Card)
Output hold time	$t_{OH}$	1.5	–	ns	$C_{CARD} < 15pF$ (1 Card)
<b>Input DAT</b>					
Input setup time	$t_{ISU2x}$	3	–	ns	$C_{CARD} < 10pF$ (1 Card)
Input hold time	$t_{IH2x}$	0.8	–	ns	$C_{CARD} < 10pF$ (1 Card)
<b>Output DAT</b>					
Output delay time	$t_{ODLY2x}$	–	7.5	ns	$C_{CARD} < 25pF$ (1 Card)
Output hold time	$t_{ODLY2x}$	1.5	–	ns	$C_{CARD} < 15pF$ (1 Card)

**20.2 PCI Express Interface Parameters**

**Table 60. PCI Express Interface Parameters**

Parameter	Symbol	Comments	Minimum	Typical	Maximum	Unit
<b>General<sup>a</sup></b>						
Baud rate	BPS	–	–	5	–	Gbaud
Reference clock peak-to-peak differential amplitude <sup>b</sup>	Vref	LVPECL	0.95	–	–	V
<b>Receiver</b>						
Differential termination	ZRX-DIFF-DC	Differential termination	80	100	120	Ω
DC impedance	ZRX-DC	DC common-mode impedance	40	50	60	Ω
Powered down termination (POS)	ZRX-HIGH-IMP-DC-POS	Power-down or RESET high impedance	100k	–	–	Ω
Powered down termination (NEG)	ZRX-HIGH-IMP-DC-NEG	Power-down or RESET high impedance	1k	–	–	Ω
Input voltage	VRX-DIFFp-p	AC coupled, differential p-p	175	–	–	mV
Jitter tolerance	TRX-EYE	Minimum receiver eye width	0.4	–	–	UI
Differential return loss	RLRX-DIFF	Differential return loss	10	–	–	dB
Common-mode return loss	RLRX-CM	Common-mode return loss	6	–	–	dB
Unexpected electrical idle enter detect threshold integration time	TRX-IDEL-DET-DIFF-ENTERTIME	An unexpected electrical idle must be recognized no longer than this time to signal an unexpected idle condition.	–	–	10	ms
Signal detect threshold	VRX-IDLE-DET-DIFFp-p	Electrical idle detect threshold	65	–	175	mV
<b>Transmitter</b>						
Output voltage	VTX-DIFFp-p	Differential p-p, programmable in 16 steps	0.8	–	1200	mV
Output voltage rise time	VTX-RISE	20% to 80%	0.125 (2.5 GT/s) 0.15 (5 GT/s)	–	–	UI
Output voltage fall time	VTX-FALL	80% to 20%	0.125 (2.5 GT/s) 0.15 (5 GT/s)	–	–	UI
RX detection voltage swing	VTX-RCV-DETECT	The amount of voltage change allowed during receiver detection.	–	–	600	mV
TX AC peak common-mode voltage (5 GT/s)	VTX-CM-AC-PP	TX AC common mode voltage (5 GT/s)	–	–	100	mV
TX AC peak common-mode voltage (2.5 GT/s)	VTX-CM-AC-P	TX AC common mode voltage (2.5 GT/s)	–	–	20	mV

**Table 60. PCI Express Interface Parameters (Cont.)**

Parameter	Symbol	Comments	Minimum	Typical	Maximum	Unit
Absolute delta of DC common-model voltage during L0 and electrical idle	VTX-CM-DC-ACTIVE-IDLE-DELTA	Absolute delta of DC common-model voltage during L0 and electrical idle.	0	–	100	mV
Absolute delta of DC common-model voltage between D+ and D-	VTX-CM-DC-LINE-DELTA	DC offset between D+ and D-	0	–	25	mV
Electrical idle differential peak output voltage	VTX-IDLE-DIFF-AC-p	Peak-to-peak voltage	0	–	20	mV
TX short circuit current	ITX-SHORT	Current limit when TX output is shorted to ground.	–	–	90	mA
DC differential TX termination	ZTX-DIFF-DC	Low impedance defined during signaling (parameter is captured for 5.0 GHz by RLTX-DIFF)	80	–	120	Ω
Differential return loss	RLTX-DIFF	Differential return loss	10 (min.) for 0.05:1.25 GHz	–	–	dB
Common-mode return loss	RLTX-CM	Common-mode return loss	6	–	–	dB
TX eye width	TTX-EYE	Minimum TX eye width	0.75	–	–	UI

a. For out-of-band PCIe signal specifications, refer to [Table 33](#).

b. The reference clock inputs comply with the requirements of the *PCI Express CEM v2.0 Specification* (see [References](#)).

## 20.3 JTAG Timing

**Table 61. JTAG Timing Characteristics**

Signal Name	Period	Output Maximum	Output Minimum	Setup	Hold
TCK	125 ns	–	–	–	–
TDI	–	–	–	20 ns	0 ns
TMS	–	–	–	20 ns	0 ns
TDO	–	100 ns	0 ns	–	–
JTAG_TRST	250 ns	–	–	–	–

## 21. Power-Up Sequence and Timing

### 21.1 Sequencing of Reset and Regulator Control Signals

The CYW4356 has two signals that allow the host to control power consumption by enabling or disabling the Bluetooth, WLAN, and internal regulator blocks. These signals are described below. Additionally, diagrams are provided to indicate proper sequencing of the signals for various operational states (see Figure 47, Figure 48, and Figure 49 and Figure 50). The timing values indicated are minimum required values; longer delays are also acceptable.

#### 21.1.1 Description of Control Signals

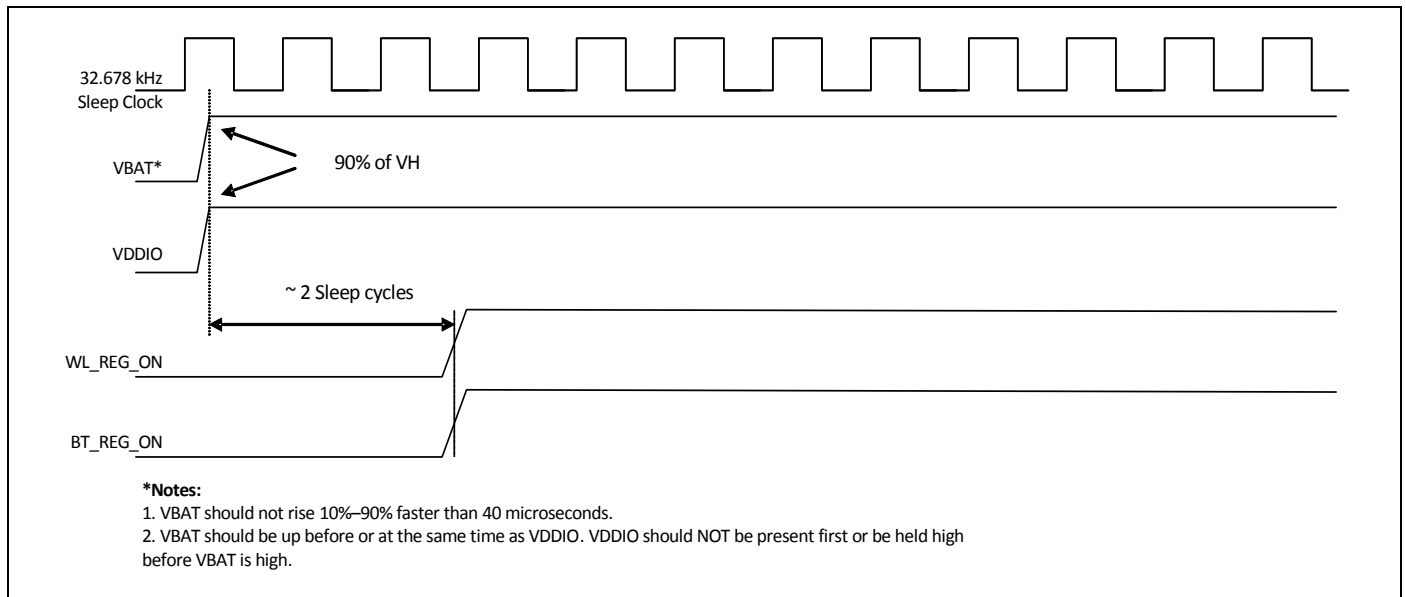
- **WL\_REG\_ON:** Used by the PMU to power up the WLAN section. It is also OR-gated with the BT\_REG\_ON input to control the internal CYW4356 regulators. When this pin is high, the regulators are enabled and the WLAN section is out of reset. When this pin is low the WLAN section is in reset. If both the BT\_REG\_ON and WL\_REG\_ON pins are low, the regulators are disabled.
- **BT\_REG\_ON:** Used by the PMU (OR-gated with WL\_REG\_ON) to power up the internal CYW4356 regulators. If both the BT\_REG\_ON and WL\_REG\_ON pins are low, the regulators are disabled. When this pin is low and WL\_REG\_ON is high, the BT section is in reset.

**Note:**

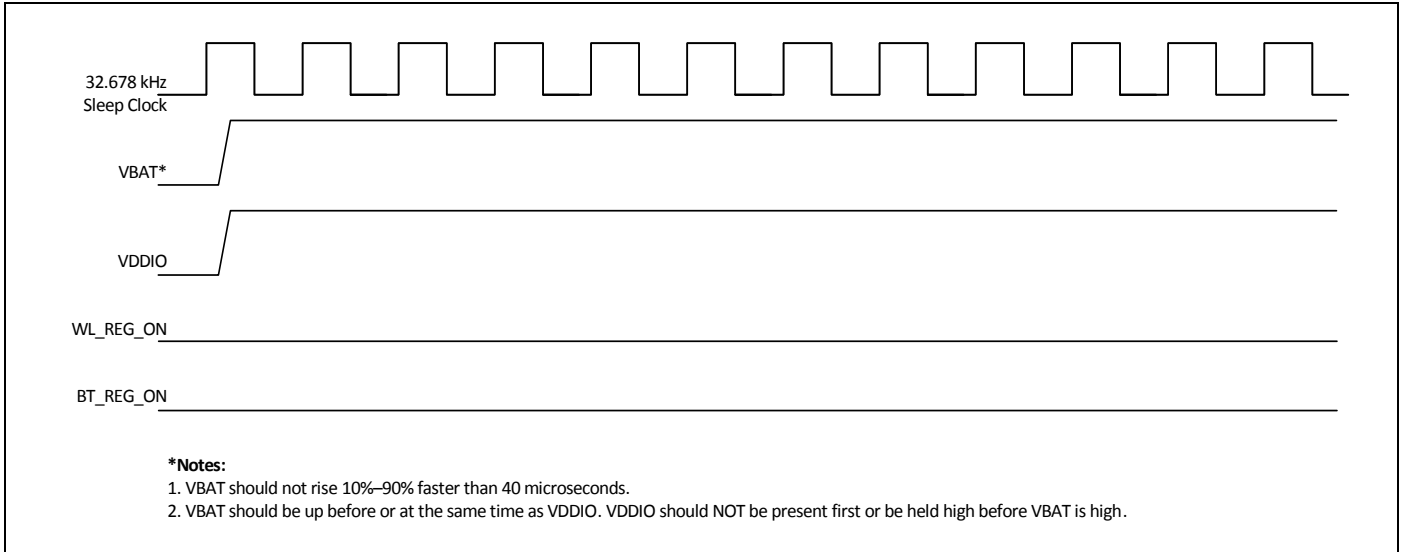
- For both the WL\_REG\_ON and BT\_REG\_ON pins, there should be at least a 10 ms time delay between consecutive toggles (where both signals have been driven low). This is to allow time for the CBUCK regulator to discharge. If this delay is not followed, then there may be a VDDIO in-rush current on the order of 36 mA during the next PMU cold start.
- The reset requirements for the Bluetooth core are also applicable for the FM core. In other words, if FM is to be used, then the Bluetooth core must be enabled.
- The CYW4356 has an internal power-on reset (POR) circuit. The device will be held in reset for a maximum of 110 ms after VDDC and VDDIO have both passed the POR threshold. Wait at least 150 ms after VDDC and VDDIO are available before initiating SDIO accesses.
- VBAT should not rise 10%–90% faster than 40 microseconds. VBAT should be up before or at the same time as VDDIO. VDDIO should NOT be present first or be held high before VBAT is high.

#### 21.1.2 Control Signal Timing Diagrams

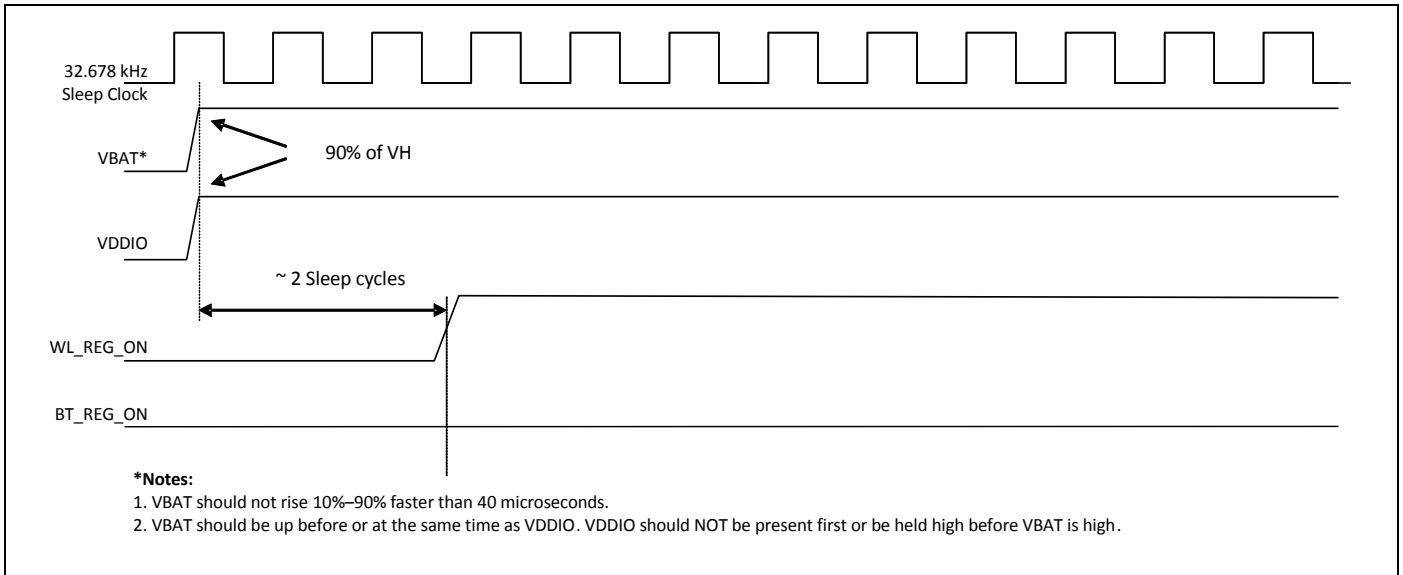
**Figure 47. WLAN = ON, Bluetooth = ON**



**Figure 48. WLAN = OFF, Bluetooth = OFF**

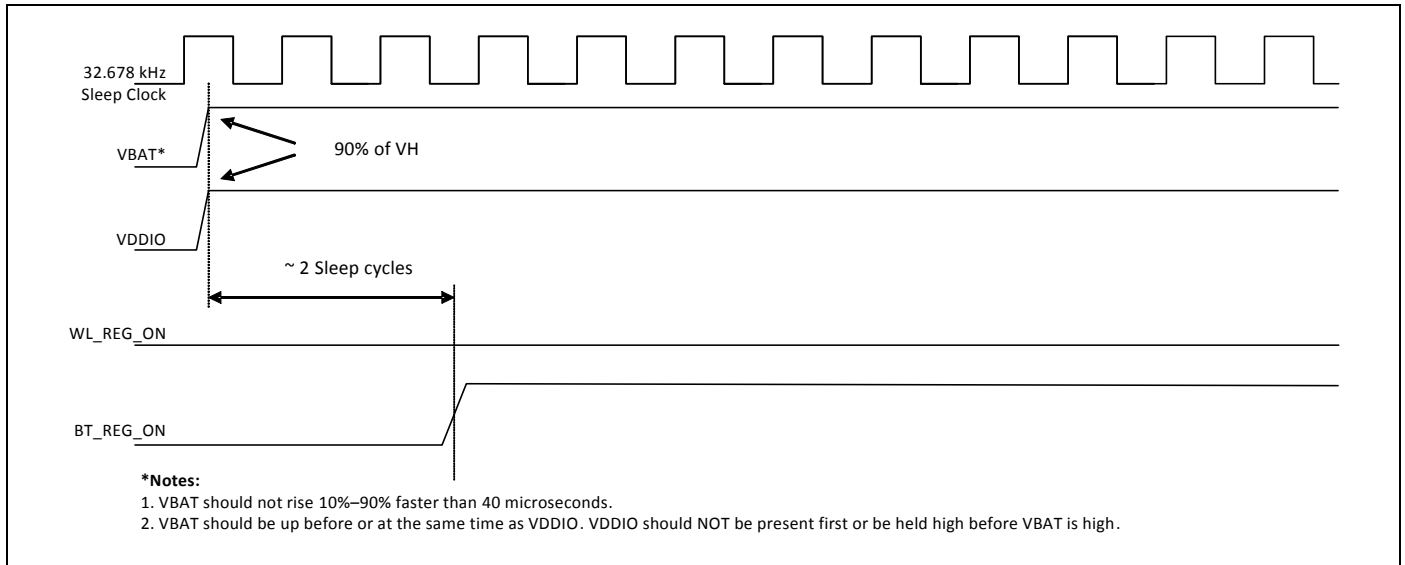


**Figure 49. WLAN = ON, Bluetooth = OFF**





**Figure 50. WLAN = OFF, Bluetooth = ON**



21.1.3 Power-up Sequences

Figure 51 shows the WLAN boot-up sequence from power-up to firmware download.

Figure 51. WLAN Boot-Up Sequence

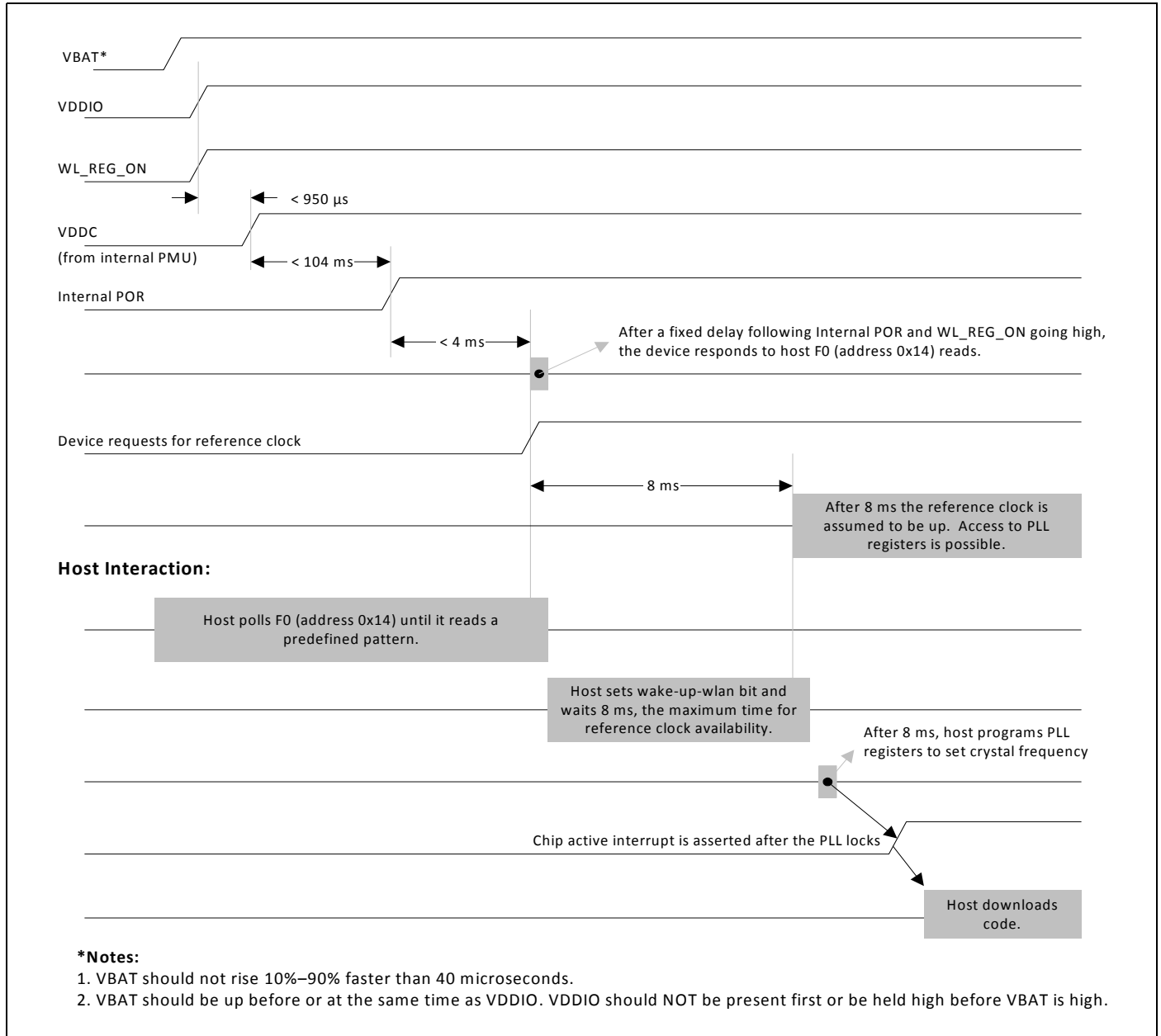


Figure 52 and Table 62 show the WLAN/PCIe power-up timing.

Figure 52. WLAN/PCIe Power-Up Timing

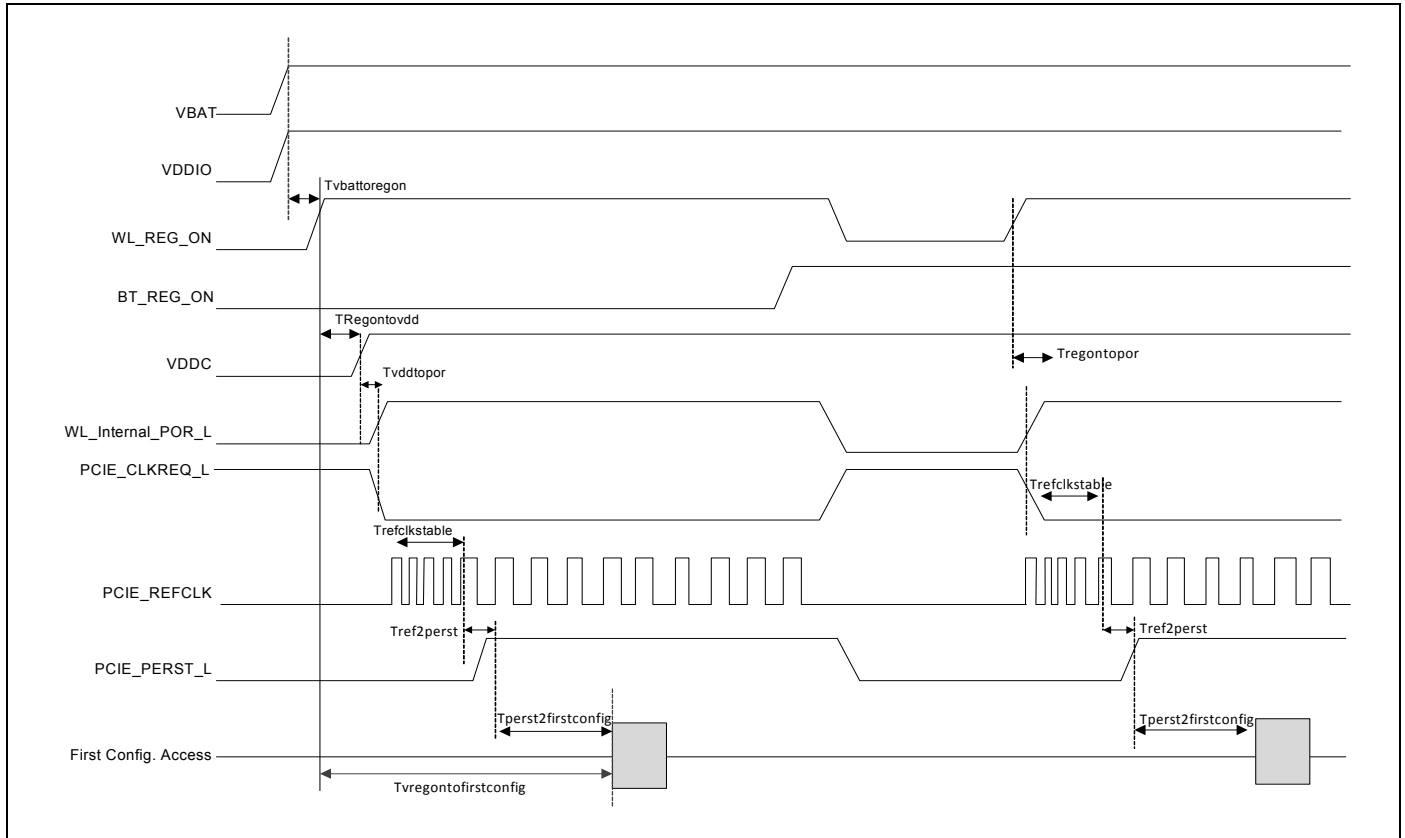


Table 62. Timing Parameters WL\_REG\_ON to Perst# Deassertion to FirstConfigAccess

Timing Parameter	Typical Value	Maximum Value
$T_{vbattoregon}$	100 $\mu$ s	—
$T_{regontovdd}$ (1.2V)	1 ms	—
$T_{vddtopor}$	57 ms	—
$T_{refclkstable}$	10 ms	—
$T_{ref2perst}$	100 $\mu$ s	—
$T_{perst2firstconfig}$	6 ms	—
$T_{vregontofirstconfig}$	—	100 ms

## 22. Package Information

### 22.1 Package Thermal Characteristics

The information in [Table 63](#) and [Table 64](#) is based on the following conditions:

- No heat sink,  $T_A = 70^\circ\text{C}$ . This is an estimate, based on a 4-layer PCB that conforms to EIA/JESD51-7 (101.6 mm × 101.6 mm × 1.6 mm) and  $P = 1.53\text{W}$  continuous dissipation.
- Absolute junction temperature limits are maintained through active thermal monitoring and driver-based techniques that may include duty-cycle limiting or turning off one of the TX chains, or both.

**Table 63. WLCSP Package Thermal Characteristics**

Characteristic	WLCSP
$\theta_{JA}$ ( $^\circ\text{C}/\text{W}$ ) (value in still air)	26.86
$\theta_{JB}$ ( $^\circ\text{C}/\text{W}$ )	2.23
$\theta_{JC}$ ( $^\circ\text{C}/\text{W}$ )	1.09
$\psi_{JT}$ ( $^\circ\text{C}/\text{W}$ )	2.48
$\psi_{JB}$ ( $^\circ\text{C}/\text{W}$ )	11.61
Maximum Junction Temperature $T_j$ ( $^\circ\text{C}$ )	125
Maximum Power Dissipation (W)	1.53

**Table 64. WLBGA Package Thermal Characteristics**

Characteristic	WLBGA
$\theta_{JA}$ ( $^\circ\text{C}/\text{W}$ ) (value in still air)	26.80
$\theta_{JB}$ ( $^\circ\text{C}/\text{W}$ )	1.66
$\theta_{JC}$ ( $^\circ\text{C}/\text{W}$ )	1.16
$\psi_{JT}$ ( $^\circ\text{C}/\text{W}$ )	1.85
$\psi_{JB}$ ( $^\circ\text{C}/\text{W}$ )	7.93
Maximum Junction Temperature $T_j$ ( $^\circ\text{C}$ )	125
Maximum Power Dissipation (W)	1.53

### 22.2 Junction Temperature Estimation and $\psi_{JT}$ Versus $\theta_{JC}$

The package thermal characterization parameter  $\psi_{JT}$  ( $\psi_{JT}$ ) yields a better estimation of actual junction temperature ( $T_j$ ) than using the junction-to-case thermal resistance parameter  $\theta_{JC}$  ( $\theta_{JC}$ ). The reason for this is that  $\theta_{JC}$  is based on the assumption that all the power is dissipated through the top surface of the package case. In actual applications, however, some of the power is dissipated through the bottom and sides of the package.  $\psi_{JT}$  takes into account the power dissipated through the top, bottom, and sides of the package. The equation for calculating the device junction temperature is:

$$T_j = T_T + P \times \psi_{JT}$$

Where:

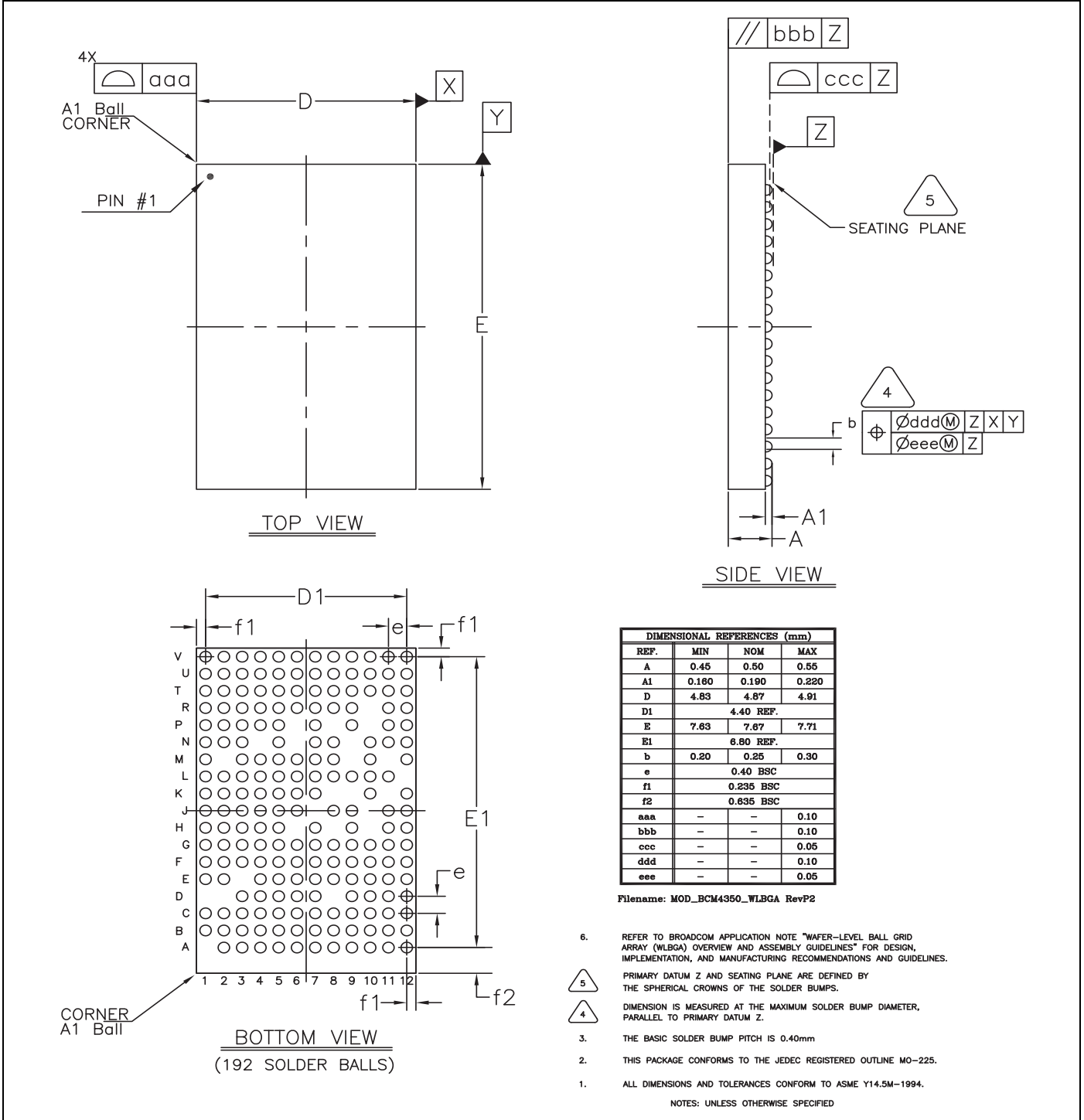
- $T_j$  = Junction temperature at steady-state condition ( $^\circ\text{C}$ )
- $T_T$  = Package case top center temperature at steady-state condition ( $^\circ\text{C}$ )
- $P$  = Device power dissipation (Watts)
- $\psi_{JT}$  = Package thermal characteristics; no airflow ( $^\circ\text{C}/\text{W}$ )

### 22.3 Environmental Characteristics

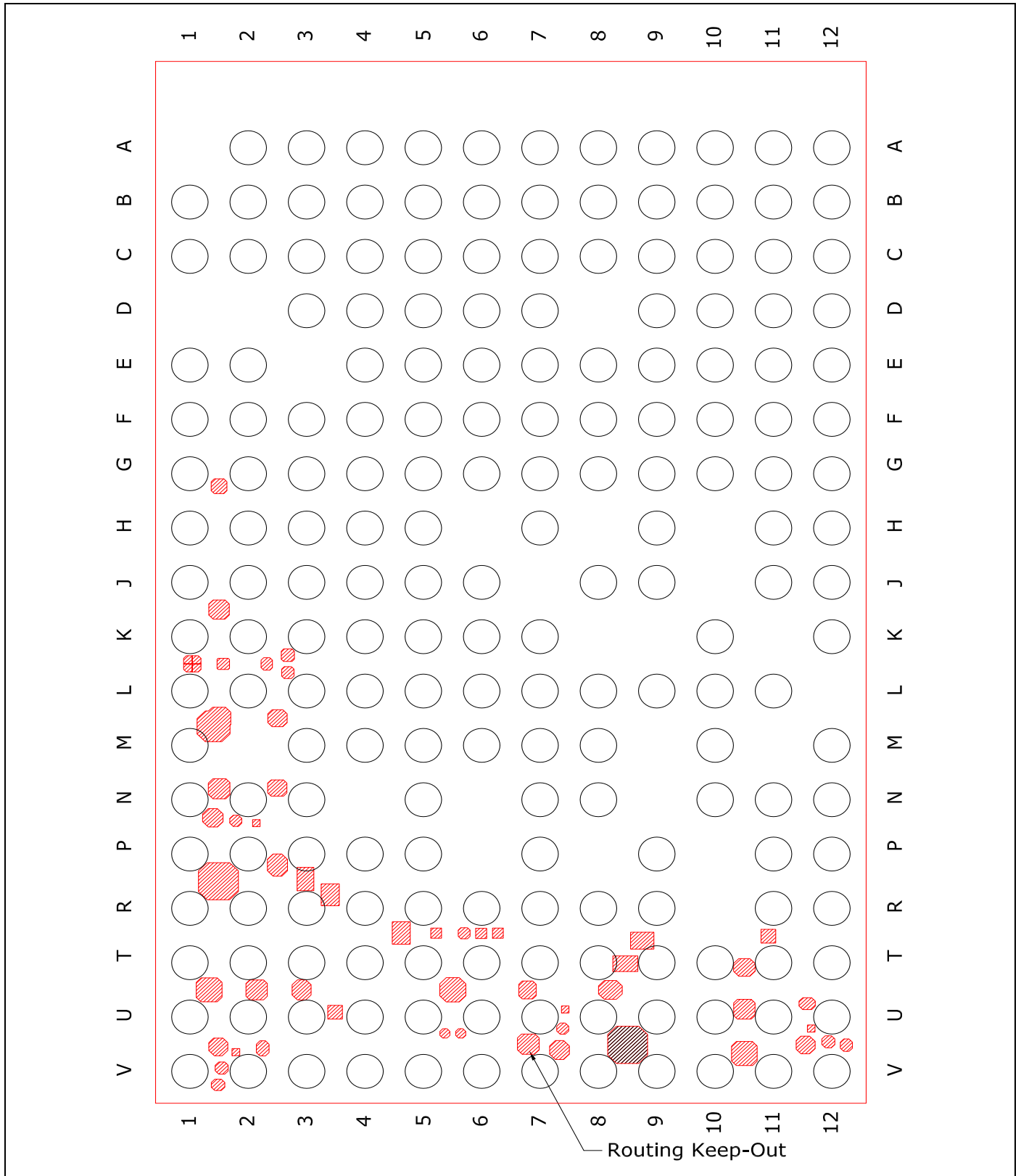
For environmental characteristics data, see [Table 31](#).

23. Mechanical Information

Figure 53. 192-Ball WLBGA Package Mechanical Information



**Figure 54. WLBGA Keep-Out Areas for PCB Layout (Top View, Balls Facing Down)**



**Figure 55. 395-Bump WLCSP Package**

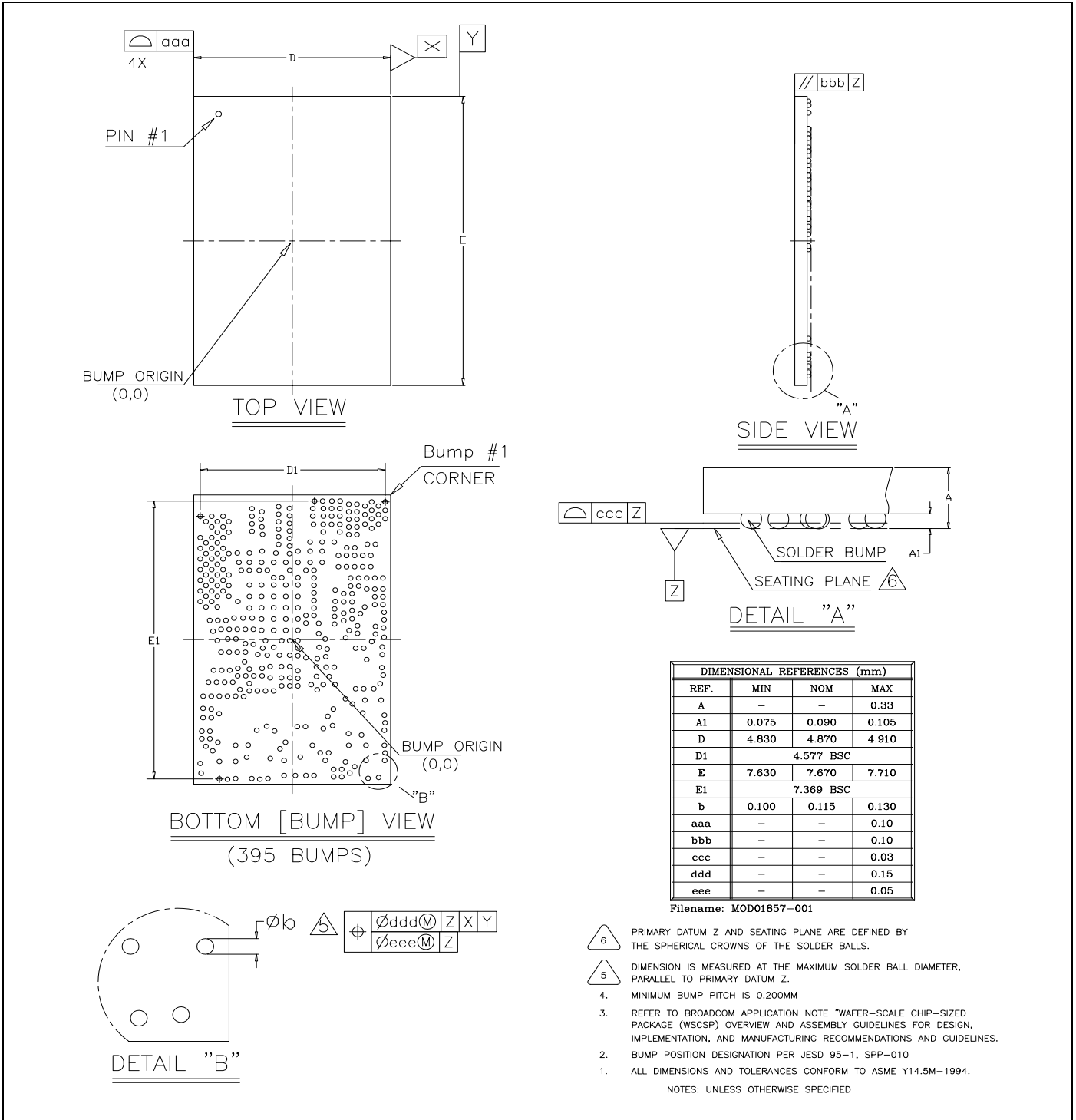
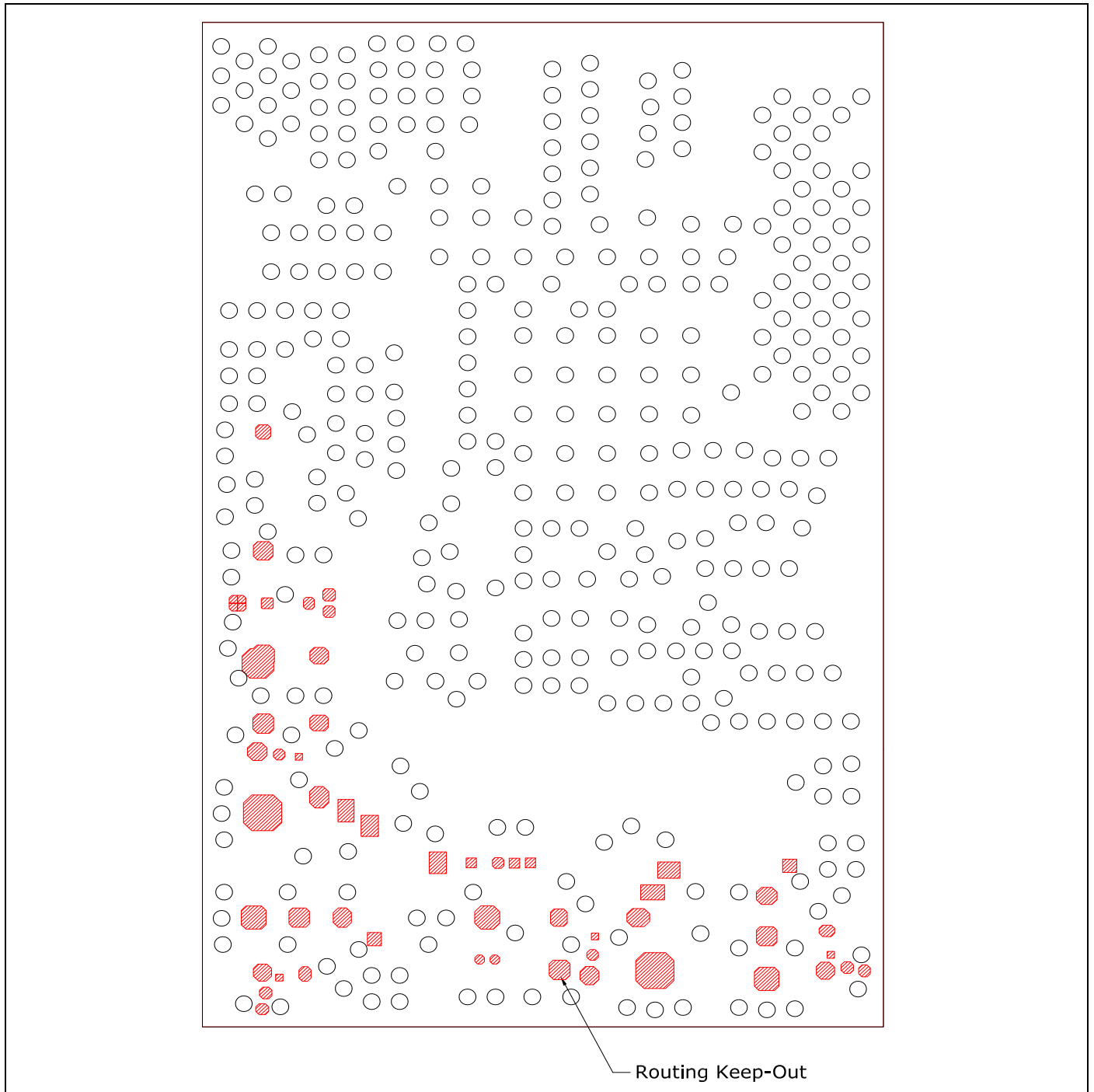


Figure 56. WLCSP Keep-Out Areas for PCB Layout (Top View, Balls Facing Down)





## 24. Ordering Information

Part Number	Package	Description	Operating Ambient Temperature
BCM4356XKUBG	192-ball WLPGA (4.87 mm × 7.67 mm, 0.4 mm pitch)	Dual-band 2.4 GHz and 5 GHz WLAN + BT 4.1 + FMRX + A4WP	–30°C to +85°C (–22°F to 185°F)
BCM4356XKWBG	395-bump WLCSP (4.87 mm × 7.67 mm, 0.2 mm pitch)	Dual-band 2.4 GHz and 5 GHz WLAN + BT 4.1 + FMRX + A4WP	–30°C to +85°C (–22°F to 185°F)

## 25. Additional Information

### 25.1 Acronyms and Abbreviations

In most cases, acronyms and abbreviations are defined on first use.

For a comprehensive list of acronyms and other terms used in Cypress documents, go to:

<http://www.cypress.com/glossary>

### 25.2 References

The references in this section may be used in conjunction with this document.

**Note:** Cypress provides customer access to technical documentation and software through its Cypress Developer Community and Downloads and Support site (see [IoT Resources](#)).

For Cypress documents, replace the “xx” in the document number with the largest number available in the repository to ensure that you have the most current version of the document.

Document (or Item) Name	Number	Source
Bluetooth MWS Coexistence 2-wire Transport Interface Specification	–	<a href="http://www.bluetooth.com">www.bluetooth.com</a>
A4WP Wireless Power Transfer System Baseline System Specification (BSS) January 2, 2013	–	<a href="http://www.a4wp.org">www.a4wp.org</a>
PCI Express CEM v2.0 Specification	–	<a href="http://www.pcisig.com">www.pcisig.com</a>

## 26. IoT Resources

Cypress provides a wealth of data at <http://www.cypress.com/internet-things-iot> to help you to select the right IoT device for your design, and quickly and effectively integrate the device into your design. Cypress provides customer access to a wide range of information, including technical documentation, schematic diagrams, product bill of materials, PCB layout information, and software updates. Customers can acquire technical documentation and software from the Cypress Support Community website (<http://community.cypress.com/>).

**Document History**

Document Title: CYW4356 Single-Chip 5G WiFi IEEE 802.11ac 2x2 MAC/Baseband/Radio with Integrated Bluetooth 4.1, FM Receiver, and Wireless Charging				
Document Number: 002-15053				
Revision	ECN	Orig. of Change	Submission Date	Description of Change
**	–	–	04/01/2014	4356-DS100-R Initial release
*A	–	–	04/24/2014	4356-DS101-R • Refer to the released document for earlier revision history.
*B	–	–	06/25/2014	4356-DS102-R <b>Updated:</b> • Pin name PCI_PME_L to PCIE_PME_L. • “BCM4356 PMU Features”. • Table 59: “PCI Express Interface Parameters” <b>Added:</b> • “Electrostatic Discharge Specifications”.
*C	–	–	05/08/2015	4356-DS103-R <b>Updated:</b> • From Advance to Preliminary Datasheet. • <a href="#">Features</a> • <a href="#">Power-Off Shutdown</a> • <a href="#">Table 5. External 32.768 kHz Sleep Clock Specifications.</a> • <a href="#">Table 22. WLCSP Signal Descriptions.</a> • <a href="#">Table 23. WLBGA Signal Descriptions.</a> • <a href="#">Table 27. GPIO Alternative Signal Functions.</a> • <a href="#">Table 33. Recommended Operating Conditions and DC Characteristics.</a> • <a href="#">Table 40. WLAN 2.4 GHz Receiver Performance Specifications.</a> • <a href="#">Table 41. WLAN 2.4 GHz Transmitter Performance Specifications.</a> • <a href="#">Table 42. WLAN 5 GHz Receiver Performance Specifications.</a> • <a href="#">Table 43. WLAN 5 GHz Transmitter Performance Specifications.</a> • <a href="#">Table 50. Typical WLAN Power Consumption.</a> • <a href="#">Table 60. PCI Express Interface Parameters.</a> • <a href="#">Figure 54. WLBGA Keep-Out Areas for PCB Layout (Top View, Balls Facing Down).</a> <b>Added:</b> • <a href="#">Figure 52. WLAN/PCIe Power-Up Timing.</a> • <a href="#">Table 62. Timing Parameters WL_REG_ON to Perst# Deassertion to FirstConfig-Access.</a> <b>Removed:</b> • Note removed from the data sheet “Values in this data sheet are design goals and are subject to change based on the results of device characterization.”
*D	5491748	UTSV	11/14/2016	Updated to Cypress Template. Added Cypress Part Numbering Scheme.

## Sales, Solutions, and Legal Information

### Worldwide Sales and Design Support

Cypress maintains a worldwide network of offices, solution centers, manufacturer’s representatives, and distributors. To find the office closest to you, visit us at [Cypress Locations](#).

#### Products

ARM® Cortex® Microcontrollers	<a href="http://cypress.com/arm">cypress.com/arm</a>
Automotive	<a href="http://cypress.com/automotive">cypress.com/automotive</a>
Clocks & Buffers	<a href="http://cypress.com/clocks">cypress.com/clocks</a>
Interface	<a href="http://cypress.com/interface">cypress.com/interface</a>
Internet of Things	<a href="http://cypress.com/iot">cypress.com/iot</a>
Lighting & Power Control	<a href="http://cypress.com/powerpsoc">cypress.com/powerpsoc</a>
Memory	<a href="http://cypress.com/memory">cypress.com/memory</a>
PSoC	<a href="http://cypress.com/psoc">cypress.com/psoc</a>
Touch Sensing	<a href="http://cypress.com/touch">cypress.com/touch</a>
USB Controllers	<a href="http://cypress.com/usb">cypress.com/usb</a>
Wireless/RF	<a href="http://cypress.com/wireless">cypress.com/wireless</a>

#### PSoC® Solutions

[PSoC 1](#) | [PSoC 3](#) | [PSoC 4](#) | [PSoC 5LP](#)

#### Cypress Developer Community

[Forums](#) | [WICED IoT Forums](#) | [Projects](#) | [Video](#) | [Blogs](#) | [Training](#) | [Components](#)

#### Technical Support

[cypress.com/support](http://cypress.com/support)

© Cypress Semiconductor Corporation, 2014-2016. This document is the property of Cypress Semiconductor Corporation and its subsidiaries, including Spansion LLC (“Cypress”). This document, including any software or firmware included or referenced in this document (“Software”), is owned by Cypress under the intellectual property laws and treaties of the United States and other countries worldwide. Cypress reserves all rights under such laws and treaties and does not, except as specifically stated in this paragraph, grant any license under its patents, copyrights, trademarks, or other intellectual property rights. If the Software is not accompanied by a license agreement and you do not otherwise have a written agreement with Cypress governing the use of the Software, then Cypress hereby grants you a personal, non-exclusive, nontransferable license (without the right to sublicense) (1) under its copyright rights in the Software (a) for Software provided in source code form, to modify and reproduce the Software solely for use with Cypress hardware products, only internally within your organization, and (b) to distribute the Software in binary code form externally to end users (either directly or indirectly through resellers and distributors), solely for use on Cypress hardware product units, and (2) under those claims of Cypress’s patents that are infringed by the Software (as provided by Cypress, unmodified) to make, use, distribute, and import the Software solely for use with Cypress hardware products. Any other use, reproduction, modification, translation, or compilation of the Software is prohibited.

TO THE EXTENT PERMITTED BY APPLICABLE LAW, CYPRESS MAKES NO WARRANTY OF ANY KIND, EXPRESS OR IMPLIED, WITH REGARD TO THIS DOCUMENT OR ANY SOFTWARE OR ACCOMPANYING HARDWARE, INCLUDING, BUT NOT LIMITED TO, THE IMPLIED WARRANTIES OF MERCHANTABILITY AND FITNESS FOR A PARTICULAR PURPOSE. To the extent permitted by applicable law, Cypress reserves the right to make changes to this document without further notice. Cypress does not assume any liability arising out of the application or use of any product or circuit described in this document. Any information provided in this document, including any sample design information or programming code, is provided only for reference purposes. It is the responsibility of the user of this document to properly design, program, and test the functionality and safety of any application made of this information and any resulting product. Cypress products are not designed, intended, or authorized for use as critical components in systems designed or intended for the operation of weapons, weapons systems, nuclear installations, life-support devices or systems, other medical devices or systems (including resuscitation equipment and surgical implants), pollution control or hazardous substances management, or other uses where the failure of the device or system could cause personal injury, death, or property damage (“Unintended Uses”). A critical component is any component of a device or system whose failure to perform can be reasonably expected to cause the failure of the device or system, or to affect its safety or effectiveness. Cypress is not liable, in whole or in part, and you shall and hereby do release Cypress from any claim, damage, or other liability arising from or related to all Unintended Uses of Cypress products. You shall indemnify and hold Cypress harmless from and against all claims, costs, damages, and other liabilities, including claims for personal injury or death, arising from or related to any Unintended Uses of Cypress products.

Cypress, the Cypress logo, Spansion, the Spansion logo, and combinations thereof, WICED, PSoC, CapSense, EZ-USB, F-RAM, and Traveo are trademarks or registered trademarks of Cypress in the United States and other countries. For a more complete list of Cypress trademarks, visit [cypress.com](http://cypress.com). Other names and brands may be claimed as property of their respective owners.