

EZ-USB[®] FX3 SuperSpeed USB Controller

Features

- Universal serial bus (USB) integration
 - USB 3.0 and USB 2.0 peripheral compliant with USB3.0 specification 1.0
 - 5-Gbps USB3.0 PHY compliant with PIPE 3.0
 - High-speed On-The-Go (HS-OTG) host and peripheral compliant with On-The-Go Supplement Version 2.0
 - Thirty-two physical endpoints
 - Support for battery charging Spec 1.1 and accessory charger adaptor (ACA) detection
- General programmable interface (GPIF™ II)
 - Programmable 100-MHz GPIF II interface enables connectivity to wide range of external devices
 - 8-/16-/32-bit data bus
 - Up to 16 configurable control signals
- Fully accessible 32-bit CPU
 - ARM926EJ Core with 200MHz operation
 - 512 kB Embedded SRAM
- Additional connectivity to following peripherals
 - I²C master controller at 1 MHz
 - I²S master (transmitter only) at sampling frequencies 32 kHz, 44.1 kHz, 48 kHz
 - UART support up to 4 Mbps
 - SPI master at 33 MHz
- Selectable clock input frequencies
 - 19.2, 26, 38.4, and 52 MHz
 - 19.2 MHz crystal input support

- Ultra low-power in core power-down mode
 - Less than 60 µA with VBATT ON and 20 µA with VBATT off
- Independent power domains for core and I/O
 - Core operation at 1.2 V
 - I²S, UART and SPI operation at 1.8 to 3.3V
 - I²C operation at 1.2 V
- 10 × 10 mm, 0.8 mm pitch Pb-free ball grid array (BGA) package
- EZ USB[®] software and DVK for easy code development

Applications

- Digital video camcorders
- Digital still cameras
- Printers
- Scanners
- Video capture cards
- Test and measurement equipment
- Surveillance cameras
- Personal navigation devices
- Medical imaging devices
- Video IP phones
- Portable media players
- Industrial cameras

Logic Block Diagram

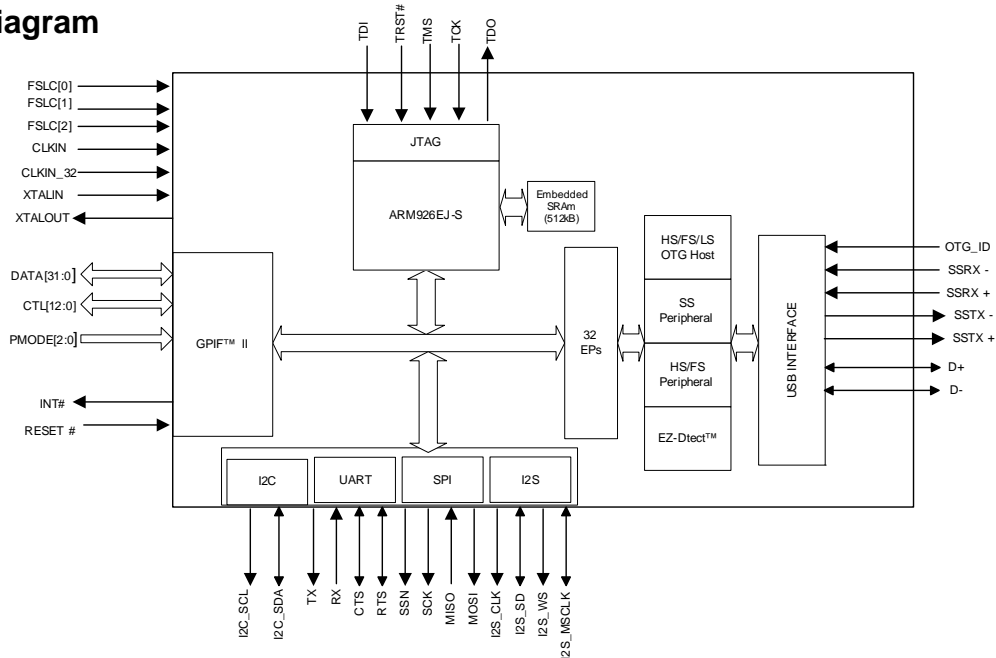

Contents

Functional Overview	3	Digital I/Os	13
Application Examples	3	GPIOs	13
USB Interface	4	System Level ESD	13
OTG.....	4	Absolute Maximum Ratings	14
ReNumeration	5	Operating Conditions	14
EZ-Dtect	5	AC Timing Parameters	16
VBUS Overvoltage Protection	5	GPIF II Timing	16
Carkit UART Mode	5	Slave FIFO Interface	19
GPIF II	6	Serial Peripherals Timing	26
CPU	6	Reset Sequence	30
JTAG Interface	7	Pin Description	32
Other Interfaces	7	Package Diagram	35
UART Interface.....	7	Ordering Information	35
I2C Interface	7	Ordering Code Definition.....	35
I2S Interface	7	Acronyms	36
SPI Interface.....	7	Document Conventions	36
Boot Options	7	Units of Measure	36
Reset	8	Document History Page	37
Hard Reset	8	Sales, Solutions, and Legal Information	38
Soft Reset.....	8	Worldwide Sales and Design Support.....	38
Clocking	8	Products	38
32-kHz Watchdog Timer Clock Input.....	8	PSoC Solutions	38
Power	9		
Power Modes	9		
Configuration Options	13		

Functional Overview

Cypress EZ-USB FX3 is the next generation USB3.0 peripheral controller providing highly integrated and flexible features that enable developers to add USB3.0 functionality to any system.

EZ-USB FX3 has a fully configurable, parallel, General Programmable Interface called GPIF II, which can connect to any processor, ASIC, or FPGA. The General Programmable Interface GPIF II is an enhanced version of the GPIF in FX2LP, Cypress's flagship USB2.0 product. It provides easy and glueless connectivity to popular interfaces such as asynchronous SRAM, asynchronous and synchronous Address Data Multiplexed interface, parallel ATA, and so on.

EZ-USB FX3 has integrated USB3.0 and USB2.0 physical layer (PHYs) along with a 32-bit ARM926EJ-S microprocessor for powerful data processing and for building custom applications. It implements an ingenious architecture which enables data transfers of 320 MBps^[1] from GPIF II to USB interface.

An integrated USB2.0 OTG controller enables applications that need dual role usage scenarios, for example EZ-USB FX3 may function as OTG Host to MSC and HID class devices.

EZ-USB FX3 contains 512 kB of on-chip SRAM for code and data. EZ-USB FX3 also provides interfaces to connect to serial peripherals such as UART, SPI, I²C, and I²S.

EZ-USB FX3 comes with the easy to use EZ-USB tools providing a complete solution for fast application development. The software development kit comes with application examples for accelerating time to market.

EZ-USB FX3 is fully compliant to USB3.0 v1.0 specification and is also backward compatible with USB2.0. It is also compliant with the Battery Charging Specification v1.1 and USB2.0 OTG Specification v2.0.

Application Examples

Figure 1 and Figure 2 show typical application diagrams for EZ-USB FX3. Figure 1 shows a typical application diagram in which EZ-USB FX3 functions as a co-processor and connects to an external processor responsible for various system level functions. Figure 2 shows a typical application diagram when EZ-USB FX3 functions as the main processor in the system.

Figure 1. EZ-USB FX3 as a Co-processor

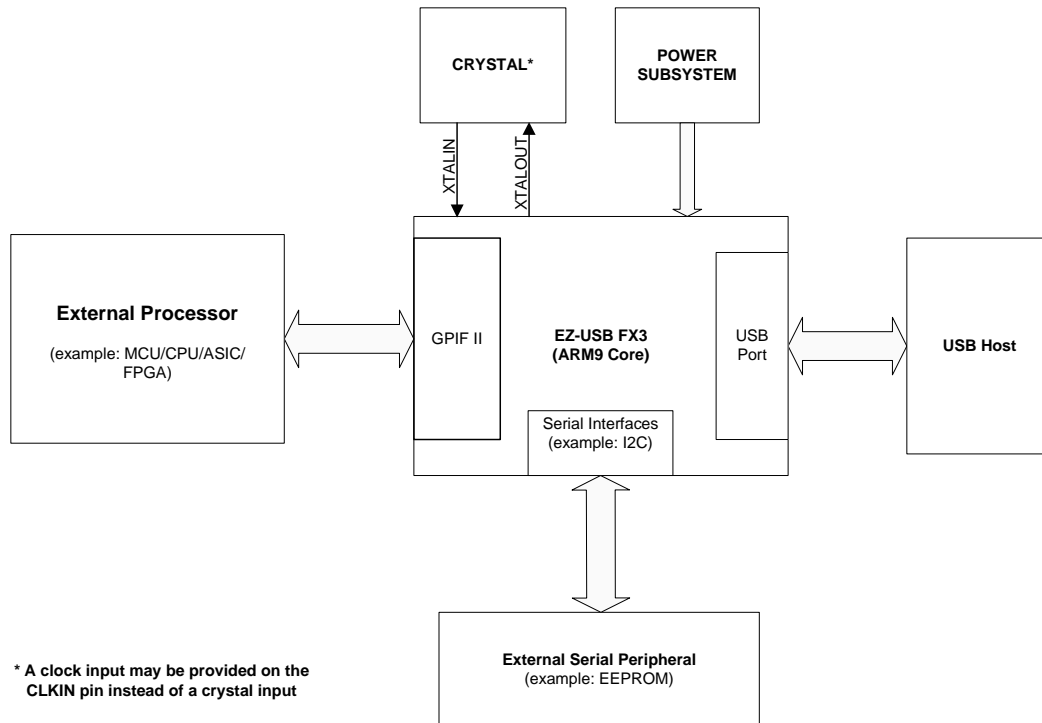

Note

1. Assuming that GPIF II is configured for 32 bit data bus synchronous interface operating at 100 MHz. This number also includes protocol overheads.

Figure 2. EZ-USB FX3 as Main Processor

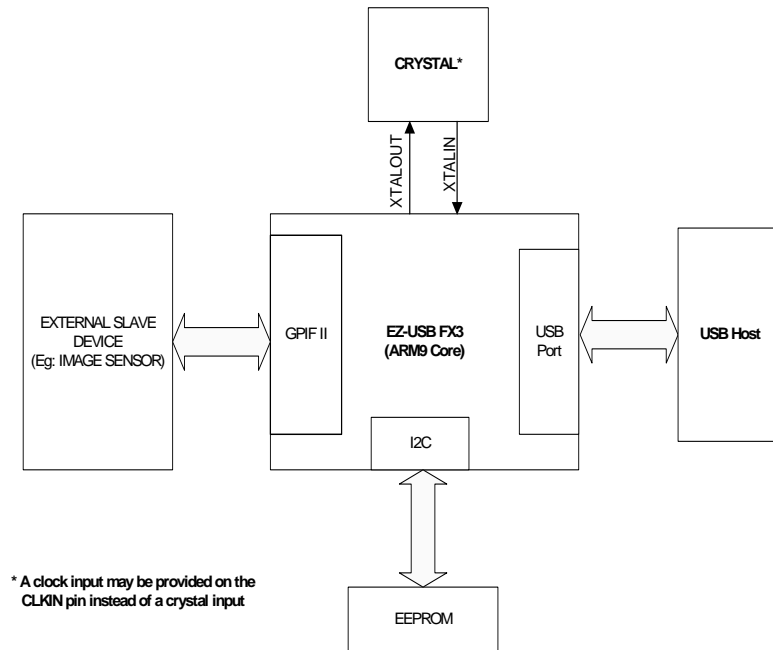

USB Interface

EZ-USB FX3 supports USB peripheral functionality compliant with USB 3.0 Specification Revision 1.0 and is also backward compatible with the USB 2.0 Specification.

EZ-USB FX3 is compliant with On-The-Go Supplement Revision 2.0. It supports Hi-Speed, Full-Speed, and Low Speed OTG dual role device capability. It is SuperSpeed, High-Speed, and Full-Speed capable as a peripheral and High-Speed, Full-Speed, and Low-Speed capable as a host.

EZ-USB FX3 supports CarKit Pass-Through UART functionality on USB D+/D- lines based on the CEA-936A specification.

EZ-USB FX3 supports up to 16 IN and 16 OUT endpoints.

EZ-USB FX3 fully supports the USB3.0 Streams feature. It also supports USB Attached SCSI (UAS) device class to optimize mass storage access performance.

As a USB peripheral, EZ-USB FX3 supports UAS, USB Video Class (UVC), Mass Storage Class (MSC), and Media Transfer Protocol (MTP) USB peripheral classes. As a USB peripheral, all other device classes are supported only in pass through mode when handled entirely by a host processor external to the device.

As an OTG host, EZ-USB FX3 supports MSC and HID device classes.

When the USB port is not in use, the PHY and transceiver may be disabled for power savings.

Figure 3. USB Interface Signals

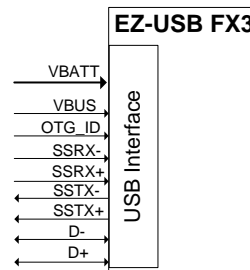

OTG

EZ-USB FX3 is compliant with the On-The-Go (OTG) Specification Revision 2.0 .

In OTG mode, EZ-USB FX3 supports both A and B device mode and supports Control, Interrupt, Bulk, and Isochronous data transfers.

EZ-USB FX3 requires an external charge pump (either stand alone or integrated into a PMIC) to power VBUS in OTG A-device mode.

The Target Peripheral List for OTG host implementation consists of MSC and HID class devices.

Attach Detection Protocol (ADP) is not supported by EZ-USB FX3.

OTG Connectivity

In OTG mode, EZ-USB FX3 can be configured to be A, B, or dual role device. It is able to connect to:

- ACA device
- Targeted USB peripheral
- SRP capable USB peripheral
- HNP capable USB peripheral
- OTG host
- HNP capable host
- OTG device

ReNumeration

Because EZ-USB FX3's configuration is soft, one chip can take on the identities of multiple distinct USB devices.

When first plugged into USB, EZ-USB FX3 enumerates automatically with the Cypress Vendor ID (0x04B4) and downloads firmware and USB descriptors over the USB interface. The downloaded firmware executes a electrical disconnect and connect. EZ-USB FX3 enumerates again, this time as a device defined by the downloaded information. This patented two step process called ReNumeration happens instantly when the device is plugged in.

EZ-Dtect

EZ-USB FX3 supports USB Charger and accessory detection (EZ-Dtect). The charger detection mechanism is in compliance with the Battery Charging Specification Revision 1.1. In addition to supporting this version of the specification EZ-USB FX3 also provides hardware support to detect the resistance values on the ID pin.

The following are the resistance ranges that EZ-USB FX3 can detect:

- Less than 10 Ω
- Less than 1 kΩ
- 65 kΩ to 72 kΩ
- 35 kΩ to 39 kΩ
- 99.96 kΩ to 104.4 kΩ (102 kΩ ± 2%)
- 119 kΩ to 132 kΩ
- Higher than 220 kΩ
- 431.2 kΩ to 448.8 kΩ (440 kΩ ± 2%)

EZ-USB FX3's charger detection feature detects a dedicated wall charger, Host/Hub charger, and Host/Hub.

VBUS Overvoltage Protection

The maximum input voltage on EZ-USB FX3's VBUS pin is 6V. A charger can supply up to 9V on VBUS, in this case, it is necessary to have an external Over voltage Protection (OVP) device to protect EZ-USB FX3 from damage on VBUS. Figure 4 shows the system application diagram with an OVP device connected on VBUS. Please refer to Table 7DC Specifications for the operating range of VBUS and VBATT.

Figure 4. System Diagram with OVP Device For VBUS

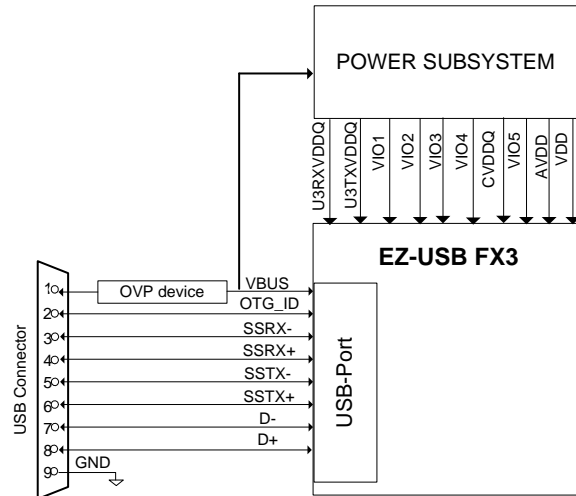

Carkit UART Mode

The USB interface supports Carkit UART mode (UART over D+/D-) for non-USB serial data transfer. This is based on the CEA-936A specification.

In Carkit UART mode, the output signaling voltage is 3.3V. When configured for Carkit UART mode, TXD of UART (output) is mapped to D- line, and RXD of UART (input) is mapped to D+ line.

In Carkit mode, EZ-USB FX3 disables the USB transceiver and D+ and D- pins serve as pass through pins to connect to the UART of the host processor. The Carkit UART signals may be routed to the GPIF II interface or to GPIO[48] and GPIO[49] as shown in Figure 5 on page 6.

A rate of up to 9600 bps is supported by EZ-USB FX3 in this mode.

Figure 5. Carkit UART Pass Through Block Diagram

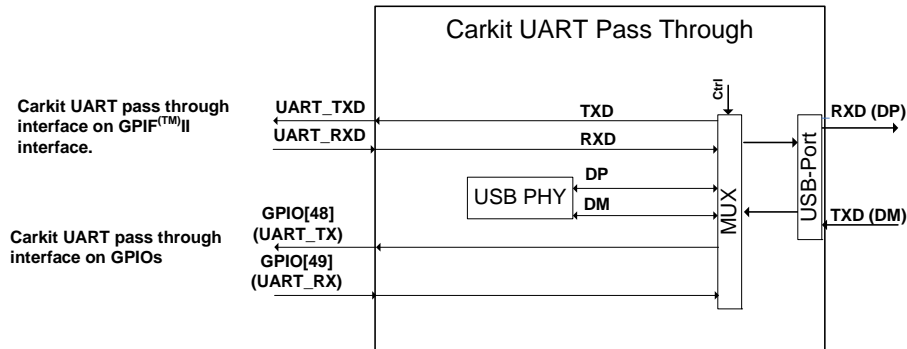

GPIF II

EZ-USB FX3 offers a high performance General Programmable Interface, GPIF II. This interface enables functionality similar to but more advanced than FX2LP's GPIF and Slave FIFO interfaces.

The GPIF II is a programmable state machine that enables a flexible interface that may function either as a master or slave in industry standard or proprietary interfaces. Both parallel and serial interfaces may be implemented with GPIF II.

The features of the GPIF II are summarized as follows:

- Functions as master or slave
- Provides 256 firmware programmable states
- Supports 8 bit, 16 bit and 32 bit parallel data bus
- Enables interface frequencies up to 100 MHz.
- Supports 14 configurable control pins when 32 bit data bus is used. All control pins can be either input/output or bidirectional.
- Supports 16 configurable control pins when 16/8 data bus is used. All control pins can be either input/output or bidirectional.

GPIFII state transitions occur based on control input signals. The control output signals are driven as a result of GPIFII state transitions. The behavior of the GPIFII state machine is defined by a GPIFII descriptor. The GPIFII descriptor is designed such that the required interface specifications are met. 8kB of memory (separate from the 512kB of embedded SRAM) is dedicated as GPIF II Waveform memory where the GPIF II descriptor is stored in a specific format.

Cypress' GPIFII Designer Tool enables fast development of GPIFII descriptors and includes examples for common interfaces.

Example implementations of GPIF II are the Asynchronous Slave FIFO and Synchronous Slave FIFO interfaces.

Slave FIFO interface

The Slave FIFO interface signals are shown in Figure 6. This interface allows an external processor to directly access upto 4 buffers internal to EZ-USB FX3. Further details of the Slave FIFO interface are described on page 19

Note: Access to all 32 buffer is also supported over Slave FIFO interface. For details, please contact Cypress Applications Support.

Figure 6. Slave FIFO Interface

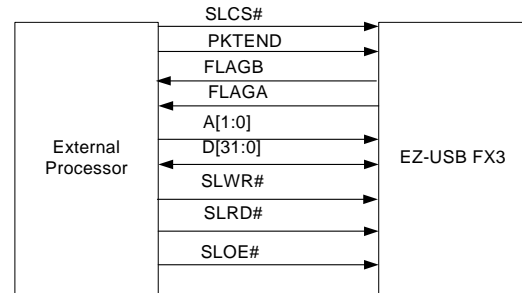

Note: Multiple Flags may be configured.

CPU

EZ-USB FX3 has an on chip 32-bit, 200 MHz ARM926EJ-S core CPU. The core has direct access to 16kB of Instruction Tightly Coupled Memory (TCM) and 8kB of Data TCM. The ARM926EJ-S core provides a JTAG interface for firmware debugging.

EZ-USB FX3 also integrates 512 kB of embedded SRAM for code and data, and 8kB of Instruction cache and Data cache.

EZ-USB FX3 implements highly efficient and flexible DMA connectivity between the various peripherals (i.e. USB, GPIF II, I²S, SPI,UART), requiring firmware to only configure data accesses between peripherals which are then managed by the DMA fabric.

EZ-USB FX3 allows for easy application development on industry standard development tools for ARM926EJ-S.

Examples of EZ-USB FX3 firmware are available with the Cypress EZ-USB FX3 Development Kit.

Software APIs that can be ported to an external processor are available with the Cypress EZ-USB FX3 Software Development Kit.

JTAG Interface

EZ-USB FX3's JTAG interface provides a standard five-pin interface for connecting to a JTAG debugger to debug firmware through the CPU-core's on-chip-debug circuitry.

Industry standard debugging tools for the ARM926EJ-S core can be used for EZ-USB FX3 application development.

Other Interfaces

EZ-USB FX3 supports the following serial peripherals:

- UART
- I²C
- I²S
- SPI

The SPI, UART and I²S interfaces are multiplexed on the Serial Peripheral port.

The [Pin List](#) on page 32 shows details of how these interfaces are multiplexed.

UART Interface

The UART interface of EZ-USB FX3 supports full duplex communication. It includes the signals noted in [Table 1](#).

Table 1. UART Interface Signals

Signal	Description
TX	Output signal
RX	Input signal
CTS	Flow control
RTS	Flow control

The UART is capable of generating a range of baud rates from 300 bps to 4608 Kbps selectable by the firmware.

I²C Interface

EZ-USB FX3 has an I²C interface compatible with the I²C Bus Specification Revision 3. EZ-USB FX3's I²C interface is capable of operating as I²C Master only, hence may be used to communicate with other I²C slave devices. For example, EZ-USB FX3 may boot from an EEPROM connected to the I²C interface, as a selectable boot option.

EZ-USB FX3's I²C Master Controller also supports Multi-master mode functionality.

The power supply for the I²C interface is VIO5, which is a separate power domain from the other serial peripherals. This is to allow the I²C interface the flexibility to operate at a different voltage than the other serial interfaces.

The bus frequencies supported by the I²C controller are 100 kHz, 400 kHz, and 1 MHz. When VIO5 is 1.2V, the maximum operating frequency supported is 100 kHz. When VIO5 is 1.8 V, 2.5 V or 3.3 V, the operating frequencies supported are 400 kHz and 1 MHz.

Note
2. F indicates Floating.

Both SCL and SDA signals of the I²C interface require external pull-up resistors. The pull-up resistors must be connected to VIO5.

I²S Interface

EZ-USB FX3 has an I²S port to support external audio codec devices. EZ-USB FX3 functions as I²S Master as transmitter only. The I²S interface consists of four signals: clock line (I2S_CLK), serial data line (I2S_SD), word select line (I2S_WS), and master system clock (I2S_MCLK). EZ-USB FX3 can generate the system clock as an output on I2S_MCLK or accept an external system clock input on I2S_MCLK.

The sampling frequencies supported by the I²S interface are 32 kHz, 44.1 kHz, and 48 kHz.

SPI Interface

EZ-USB FX3 supports an SPI Master interface on the Serial Peripherals port. The maximum frequency of operation is 33 MHz.

The SPI controller supports four modes of SPI communication with Start-Stop clock. The SPI controller is a single master controller with a single automated SSN control. It supports transaction sizes from 4-bit to 32 bits long.

Boot Options

EZ-USB FX3 can load boot images from various sources, selected by the configuration of the PMODE pins. The boot options for EZ-USB FX3 are listed as follows:

- Boot from USB
- Boot from I²C
- Boot from SPI (SPI devices supported are M25P16 (16 Mbit), M25P80 (8 Mbit), and M25P40 (4 Mbit)) or their equivalents
- Boot from GPIF II ASync ADMUX mode
- Boot from GPIF II Sync ADMUX mode
- Boot from GPIF II ASync SRAM mode

Table 2. Booting Options for EZ-USB FX3

PMODE[2:0] ^[2]	Boot From
F00	Sync ADMUX (16-bit)
F01	ASync ADMUX (16-bit)
F11	USB boot
F0F	ASync SRAM (16-bit)
F1F	I ² C, On Failure, USB Boot is Enabled
1FF	I ² C only
0F1	SPI, On Failure, USB Boot is Enabled

Reset

Hard Reset

A hard reset is initiated by asserting the Reset# pin on EZ-USB FX3. The specific reset sequence and timing requirements are detailed in [Figure 17](#) and [Table 15](#).

Soft Reset

Soft Reset involves the processor setting the appropriate bits in the PP_INIT control register. There are two types of Soft Reset:

- CPU Reset - The CPU Program Counter is reset. Firmware does not need to be reloaded following a CPU Reset.
- Whole Device Reset - This reset is identical to Hard Reset. The firmware must be reloaded following a Whole Device Reset.

Clocking

EZ-USB FX3 allows either a crystal to be connected between the XTALIN and XTALOUT pins or an external clock to be connected at the CLKIN pin.

Crystal frequency supported is 19.2 MHz, while the external clock frequencies supported are 19.2, 26, 38.4, and 52 MHz.

EZ-USB FX3 has an on-chip oscillator circuit that uses an external 19.2 MHz (± 100 ppm) crystal (when the crystal option is used). The FSLC[2:0] pins must be configured appropriately to select the crystal option/clock frequency option. The configuration options are shown in [Table 3](#).

Clock inputs to EZ-USB FX3 must meet the phase noise and jitter requirements specified in [Table 4](#).

The input clock frequency is independent of the clock/data rate of EZ-USB FX3 core or any of the device interfaces (including P-Port and S-Port). The internal PLL applies the appropriate clock multiply option depending on the input frequency.

Table 3. Crystal/Clock Frequency Selection

FSLC[2]	FSLC[1]	FSLC[0]	Crystal/ Clock Frequency
0	0	0	19.2 MHz crystal
1	0	0	19.2 MHz input CLK
1	0	1	26 MHz input CLK
1	1	0	38.4 MHz input CLK
1	1	1	52 MHz input CLK

Table 4. Input Clock Specifications for EZ-USB FX3

Parameter	Description	Specification		Units
		Min	Max	
Phase noise	100 Hz Offset	-	-75	dB
	1 kHz Offset	-	-104	dB
	10 kHz Offset	-	-120	dB
	100 kHz Offset	-	-128	dB
	1 MHz Offset	-	-130	dB
Maximum frequency deviation		-	150	ppm
Duty cycle		30	70	%
Overshoot		-	3	%
Undershoot		-	-3	%
Rise time/fall time		-	3	ns

32-kHz Watchdog Timer Clock Input

EZ-USB FX3 includes a watchdog timer. The watchdog timer can be used to interrupt the ARM926EJ-S core, auto wakeup EZ-USB FX3 in Standby mode and reset the ARM926EJ-S core. The watch dog timer runs off a 32 kHz clock. This 32 kHz clock may optionally be supplied from an external source on a dedicated pin of EZ-USB FX3.

The watchdog timer can be disabled by firmware.

Requirements for the optional 32 kHz clock input are listed in [Table 5](#).

Table 5. 32 kHz Clock Input Requirements

Parameter	Min	Max	Units
Duty cycle	40	60	%
Frequency deviation	-	± 200	ppm
Rise time/fall time	-	3	ns

Power

EZ-USB FX3 has the following power supply domains.

IO_VDDQ: This refers to a group of independent supply domains for digital I/Os. The voltage level on these supplies is 1.8V to 3.3V. EZ-USB FX3 provides six independent supply domains for digital I/Os listed as follows. Refer to [Table 16](#) for details on the signals assigned to each power domain.

- VIO1 - GPIF II I/O power supply domain
- VIO2 - IO2 power supply domain
- VIO3 - IO3 power supply domain
- VIO4 - UART/SPI/I²S power supply domain
- VIO5 - I²C and JTAG power supply domain (1.2V to 3.3V is supported)
- CVDDQ - Clock power supply domain
- **V_{DD}**: This is the supply voltage for the logic core. The nominal supply voltage level is 1.2 V. This supplies the core logic circuits. The same supply must also be used for the following:
 - **AVDD:** This is the 1.2 V supply for the PLL, crystal oscillator and other core analog circuits
 - **U3TXVDDQ/U3RXVDDQ:** These are the 1.2 V supply voltages for the USB 3.0 interface.

VBATT/VBUS: This is the 3.2V to 6V battery power supply for the USB I/O, and analog circuits. This supply powers the USB transceiver through EZ-USB FX3's internal voltage regulator. VBATT is internally regulated to 3.3V.

Power Modes

EZ-USB FX3 supports different power modes as follows:

- Normal mode: This is the full functional operating mode. In this mode the internal CPU clock and the internal PLLs are enabled.

Normal operating power consumption does not exceed the sum of ICC_CORE max and ICC_USB max (please refer to [Table 7](#) for current consumption specifications).

The I/O power supplies (VIO1, VIO2, VIO3, VIO4, VIO5) may be turned off when the corresponding interface is not in use.

EZ-USB FX3 supports four low power modes:

- Suspend mode with USB 3.0 PHY enabled (L1)
- Suspend mode with USB 3.0 PHY disabled (L2)
- Standby mode (L3)
- Core power down mode (L4)

The different low power modes are described in [Table 6](#)..

Table 6. Entry and Exit Methods for Low Power Modes

Low Power Mode	Characteristics	Methods of Entry	Methods of Exit
Suspend Mode with USB 3.0 PHY Enabled (L1)	<ul style="list-style-type: none"> ■ The power consumption in this mode does not exceed ISB_1 ■ USB 3.0 PHY is enabled and is in U3 mode (one of the suspend modes defined by the USB3.0 specification). This one block alone is operational with its internal clock while all other clocks are shut down ■ All I/Os maintain their previous state ■ Power supply for the wakeup source and core power must be retained. All other power domains can be turned on/off individually ■ The states of the configuration registers, buffer memory and all internal RAM are maintained ■ All transactions must be completed before EZ-USB FX3 enters Suspend mode (state of outstanding transactions are not preserved) ■ The firmware resumes operation from where it was suspended (except when woken up by RESET# assertion) because the program counter does not reset 	<ul style="list-style-type: none"> ■ Firmware executing on ARM926EJ-S core can put EZ-USB FX3 into suspend mode. For example, on USB suspend condition, firmware may decide to put EZ-USB FX3 into suspend mode ■ External Processor, through the use of mailbox registers can put EZ-USB FX3 into suspend mode 	<ul style="list-style-type: none"> ■ D+ transitioning to low or high ■ D- transitioning to low or high ■ Impedance change on OTG_ID pin ■ Resume condition on SSRX +/- ■ Detection of VBUS ■ Level detect on UART_CTS (programmable polarity) ■ GPIF II interface assertion of CTL[0] ■ Assertion of RESET#

Table 6. Entry and Exit Methods for Low Power Modes (continued)

Low Power Mode	Characteristics	Methods of Entry	Methods of Exit
Suspend Mode with USB 3.0 PHY Disabled (L2)	<ul style="list-style-type: none"> ■ The power consumption in this mode does not exceed ISB_2 ■ USB 3.0 PHY is disabled and the USB interface is in suspend mode ■ The clocks are shut off. The PLLs are disabled ■ All I/Os maintain their previous state ■ USB interface maintains the previous state ■ Power supply for the wakeup source and core power must be retained. All other power domains can be turned on/off individually ■ The states of the configuration registers, buffer memory and all internal RAM are maintained ■ All transactions must be completed before EZ-USB FX3 enters Suspend mode (state of outstanding transactions are not preserved) ■ The firmware resumes operation from where it was suspended (except when woken up by RESET# assertion) because the program counter does not reset 	<ul style="list-style-type: none"> ■ Firmware executing on ARM926EJ-S core can put EZ-USB FX3 into suspend mode. For example, on USB suspend condition, firmware may decide to put EZ-USB FX3 into suspend mode ■ External Processor, through the use of mailbox registers can put EZ-USB FX3 into suspend mode 	<ul style="list-style-type: none"> ■ D+ transitioning to low or high ■ D- transitioning to low or high ■ Impedance change on OTG_ID pin ■ Resume condition on SSRX +/- ■ Detection of VBUS ■ Level detect on UART_CTS (programmable polarity) ■ GPIF II interface assertion of CTL[0] ■ Assertion of RESET#

Table 6. Entry and Exit Methods for Low Power Modes (continued)

Low Power Mode	Characteristics	Methods of Entry	Methods of Exit
Standby Mode (L3)	<ul style="list-style-type: none"> ■ The power consumption in this mode does not exceed ISB₃ ■ All configuration register settings and program/data RAM contents are preserved. However, data in the buffers or other parts of the data path, if any, is not guaranteed. Therefore, the external processor should take care that needed data is read before putting EZ-USB FX3 into this Standby Mode ■ The program counter is reset on waking up from Standby mode ■ GPIO pins maintain their configuration ■ Crystal oscillator is turned off ■ Internal PLL is turned off ■ USB transceiver is turned off ■ ARM926EJ-S core is powered down. Upon wakeup, the core re-starts and runs the program stored in the program/data RAM ■ Power supply for the wakeup source and core power must be retained. All other power domains can be turned on/off individually 	<ul style="list-style-type: none"> ■ Firmware executing on ARM926EJ-S core or external processor configures the appropriate register 	<ul style="list-style-type: none"> ■ Detection of VBUS ■ Level detect on UART_CTS (Programmable Polarity) ■ GPIF II interface assertion of CTL[0] ■ Assertion of RESET#
Core Power Down Mode (L4)	<ul style="list-style-type: none"> ■ The power consumption in this mode does not exceed ISB₄ ■ Core power is turned off ■ All buffer memory, configuration registers and the program RAM do not maintain state. It is necessary to reload the firmware on exiting from this mode ■ In this mode, all other power domains can be turned on/off individually 	<ul style="list-style-type: none"> ■ Turn off V_{DD} 	<ul style="list-style-type: none"> ■ Reapply VDD ■ Assertion of RESET#

Configuration Options

Configuration options are available for specific usage models. Contact Cypress Applications/Marketing for details.

Digital I/Os

EZ-USB FX3 provides firmware controlled pull up or pull down resistors internally on all digital I/O pins. The pins can be pulled high through an internal 50 k Ω resistor or can be pulled low through an internal 10 k Ω resistor to prevent the pins from floating. The I/O pins may have the following states:

- Tristated (High-Z)
- Weak Pull up (via internal 50 k Ω)
- Pull down (via internal 10 k Ω)
- Hold (I/O hold its value) when in low power modes
- The JTAG signals TDI, TMC, TRST# signals have fixed 50 k Ω internal pull-ups & the TCK signal has a fixed 10 k Ω pull down resistor.

GPIOs

EZ-USB allows for a flexible pin configuration both on the GPIF II and the serial peripheral interfaces. Any unused control pins on the GPIF II interface may be used as GPIOs. Similarly, any unused pins on the serial peripheral interfaces may be configured as GPIOs. Please refer to the Pin List for pin configuration options.

All GPIF II and GPIO pins support an external load of up to 16pF per pin.

EMI

EZ-USB FX3 meets EMI requirements outlined by FCC 15B (USA) and EN55022 (Europe) for consumer electronics. EZ-USB FX3 can tolerate reasonable EMI conducted by aggressor outlined by these specifications and continue to function as expected.

System Level ESD

EZ-USB FX3 has built-in ESD protection on the D+, D-, GND pins on the USB interface. The ESD protection levels provided on these ports are:

- ± 2.2 KV Human Body Model (HBM) based on JESD22-A114 Specification
- ± 6 KV Contact Discharge and ± 8 KV Air Gap Discharge based on IEC61000-4-2 level 3A
- ± 8 KV Contact Discharge and ± 15 KV Air Gap Discharge based on IEC61000-4-2 level 4C.

This protection ensures the device will continue to function after ESD events up to the levels stated.

The SSRX+, SSRX-, SSTX+, SSTX- pins only have up to +/- 2.2KV Human Body Model (HBM) internal ESD protection.

Absolute Maximum Ratings

Exceeding maximum ratings may shorten the useful life of the device.

- Storage temperature..... -65 °C to +150 °C
- Ambient temperature with power supplied (Industrial)..... -40 °C to +85 °C
- Supply voltage to ground potential
V_{DD}, AVDDQ TBD
- VIO1, VIO2, VIO3, VIO4, VIO5.....TBD
- U3TXVDDQ, U3RXVDDQ.....TBD
- DC input voltage to any input pin.....TBD
- DC voltage applied to outputs in high Z state..... TBD
- Static discharge voltage
ESD protection levels.....
± 2.2 KV human body model (HBM) based on JESD22-A114
- Additional ESD protection levels on D+, D-,
GND pins and serial Peripherals pins..... ± 6 KV

Contact discharge, ± 8 KV air gap discharge based on IEC61000-4-2 level 3A and ± 8 KV contact discharge, ± 15 KV air gap discharge based on IEC61000-4-2 level 4C

- Latch up current..... > 200 mA
- Maximum output short circuit current
for all I/O configurations. (Vout = 0V)[1]..... -100 mA

Operating Conditions

- T_A (ambient temperature under bias)
- Industrial..... -40 °C to +85 °C
- V_{DD}, AVDDQ, U3TXVDDQ, U3RXVDDQ
- Supply voltage..... 1.15 V to 1.25 V
- VBATT supply voltage..... 3.2 V to 6 V
- VIO1, VIO2, VIO3, VIO4, CVDDQ
- Supply voltage..... 1.7 V to 3.6 V
- VIO5 supply voltage..... 1.15 V to 3.6 V

Table 7. DC Specifications

Parameter	Description	Min	Max	Units	Notes
V _{DD}	Core voltage supply	1.15	1.25	V	1.2 V typical
AVDD	Analog voltage supply	1.15	1.25	V	1.2 V typical
VIO1	GPIO II I/O power supply domain	1.7	3.6	V	1.8, 2.5 and 3.3 V typical
VIO2	IO2 power supply domain	1.7	3.6	V	1.8, 2.5 and 3.3 V typical
VIO3	IO3 power supply domain	1.7	3.6	V	1.8, 2.5 and 3.3 V typical
VIO4	UART/SPI/I2S power supply domain	1.7	3.6	V	1.8, 2.5 and 3.3 V typical
VBATT	USB voltage supply	3.2	6	V	3.7 V typical
VBUS	USB voltage supply	4.1	6	V	5 V typical
U3TXVDDQ	USB3.0 1.2-V supply	1.15	1.25	V	1.2 V typical
U3RXVDDQ	USB3.0 1.2-V supply	1.15	1.25	V	1.2 V typical
CVDDQ	Clock voltage supply	1.7	3.6	V	1.8, 3.3 V typical
VIO5	I ² C and JTAG voltage supply	1.15	3.6	V	1.2, 1.8, 2.5 and 3.3 V typical
VIH1	Input HIGH voltage 1	0.625 × VCC	VCC + 0.3	V	For 2.0V ≤ VCC ≤ 3.6 V (except USB port)
VIH2	Input HIGH voltage 2	VCC - 0.4	VCC + 0.3	V	For 1.7 V ≤ VCC ≤ 2.0 V (except USB port)
VIL	Input LOW voltage	-0.3	0.25 × VCC	V	
VOH	Output HIGH voltage	0.9 × VCC	-	V	IOH (max) = -100 μA
VOL	Output LOW voltage	-	0.1 × VCC	V	IOL (min) = +100 μA
IIX	Input leakage current	-1	1	μA	All I/O signals held at VDDQ (For I/Os that have a pull-up/down resistor connected, the leakage current increases by VDDQ/R _{pu} or VDDQ/R _{pd})
IOZ	Output High-Z leakage current	-1	1	μA	All I/O signals held at VDDQ

Table 7. DC Specifications (continued)

Parameter	Description	Min	Max	Units	Notes
ICC Core	Core and analog voltage operating current	–	200	mA	Total current through AVDD, VDD
ICC USB	USB voltage supply operating current	–	60	mA	
ISB1	Total suspend current during suspend mode with USB 3.0 PHY enabled (L1)	–	–	mA	Core Current: 1.5 mA IO Current: 20 uA USB Current: 2 mA for Typical PVT (Typical silicon, all power supplies at their respective nominal levels at 25°C.)
ISB2	Total suspend current during suspend mode with USB 3.0 PHY disabled (L2)	–	–	mA	Core Current: 250 uA IO Current: 20 uA USB Current: 1.2 mA for Typical PVT (Typical silicon, all power supplies at their respective nominal levels at 25°C.)
ISB3	Total standby current during standby mode (L3)	–	–	μA	Core Current: 60 uA IO Current: 20 uA USB Current: 40 uA for Typical PVT (Typical silicon, all power supplies at their respective nominal levels at 25°C.)
ISB4	Total standby current during core power-down mode (L4)	–	–	μA	Core Current: 0 uA IO Current: 20 uA USB Current: 40 uA for Typical PVT (Typical silicon, all power supplies at their respective nominal levels at 25°C.)
V _{RAMP}	Voltage ramp rate on core and I/O supplies	0.2	50	V/ms	Voltage ramp must be monotonic
V _N	Noise level permitted on V _{DD} and I/O supplies	–	100	mV	Max p-p noise level permitted on all supplies except AVDD
V _{N_AVDD}	Noise level permitted on AVDD supply	–	20	mV	Max p-p noise level permitted on AVDD

AC Timing Parameters

GPIF II Timing

Figure 7. GPIF II Timing in Synchronous Mode

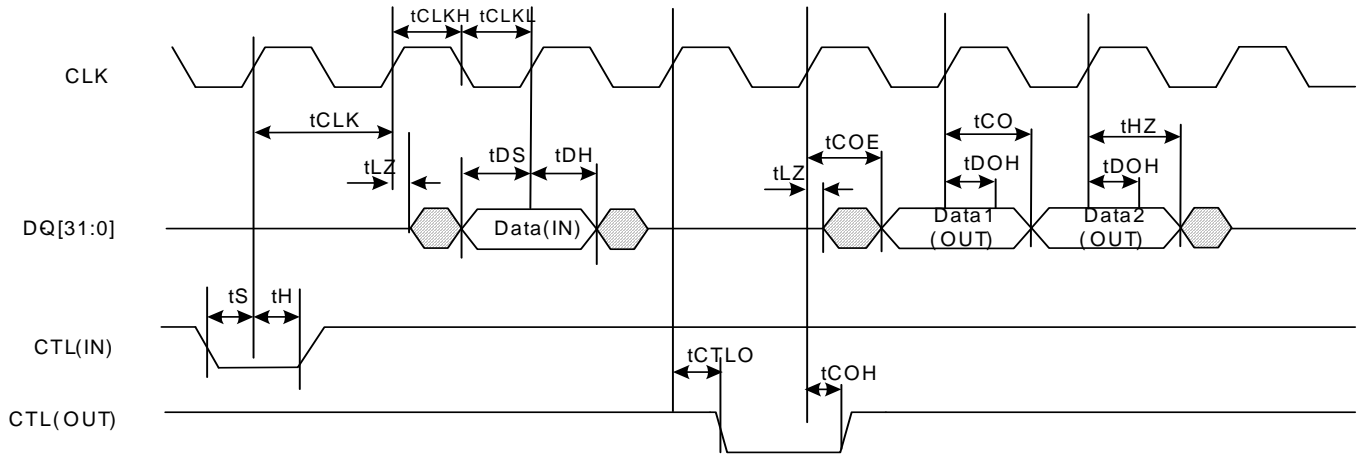

Table 8. GPIF II Timing Parameters in Synchronous Mode^[3]

Parameter	Description	Min	Max	Unit
Frequency	Interface clock frequency	–	100	MHz
tCLK	Interface clock period	10	–	ns
tCLKH	Clock high time	4	–	ns
tCLKL	Clock low time	4	–	ns
tS	CTL input to clock setup time (Sync speed =1)	2	–	ns
tH	CTL input to clock hold time (Sync speed =1)	0.5	–	ns
tDS	Data in to clock setup time (Sync speed =1)	2	–	ns
tDH	Data in to clock hold time (Sync speed =1)	0.5	–	ns
tCO	Clock to data out propagation delay when DQ bus is already in output direction(Sync speed =1)	–	8	ns
tCOE	Clock to data out propagation delay when DQ lines change to output from tristate and valid data is available on the DQ bus (Sync speed =1)	-	9	
tCTLO	Clock to CTL out propagation delay (Sync speed =1)	–	8	ns
tDOH	Clock to data out hold	2	–	ns
tCOH	Clock to CTL out hold	0	–	ns
tHZ	Clock to High-Z	–	8	ns
tLZ	Clock to Low-Z (Sync speed =1)	0	–	ns
tS_ss0	CTL input/data input to clock setup time (Sync speed = 0)	5	–	ns
tH_ss0	CTL input/data input to clock hold time (Sync speed = 0)	2.5	–	ns
tCO_ss0	Clock to data out / CTL out propagation delay (sync speed = 0)	–	15	ns
tLZ_ss0	Clock to low-Z (sync speed = 0)	2	–	ns

Note

3. All parameters guaranteed by design and validated through characterization.

Figure 8. GPIF II Timing in Asynchronous Mode

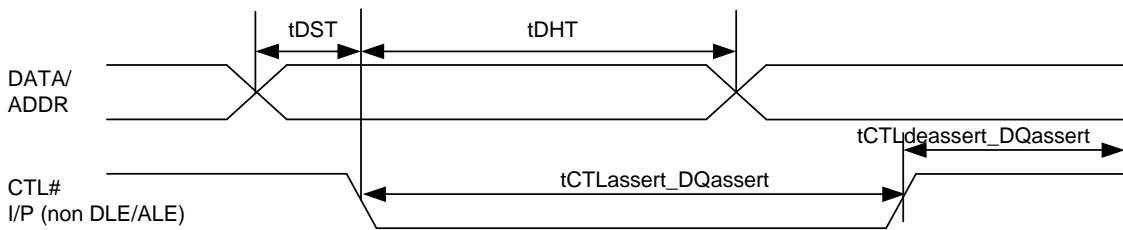
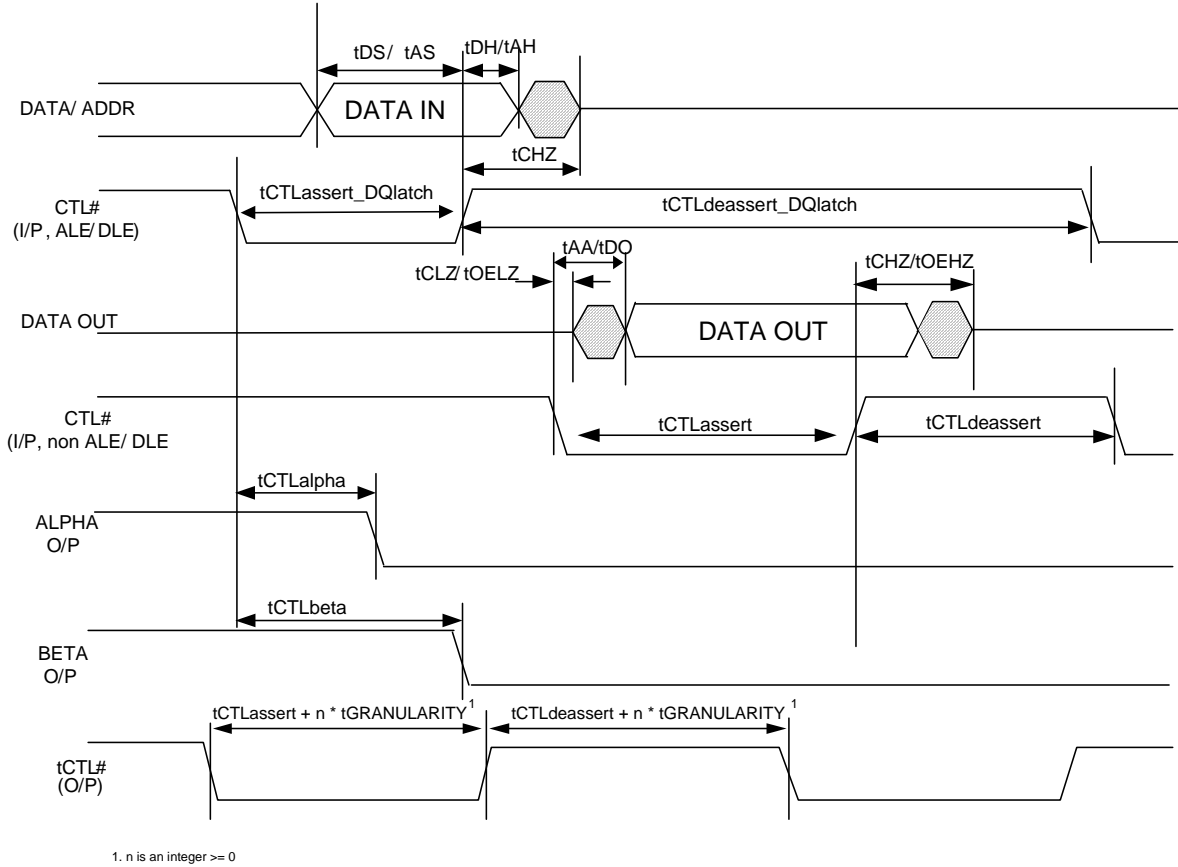

Figure 9. GPIF II Timing in Asynchronous DDR Mode

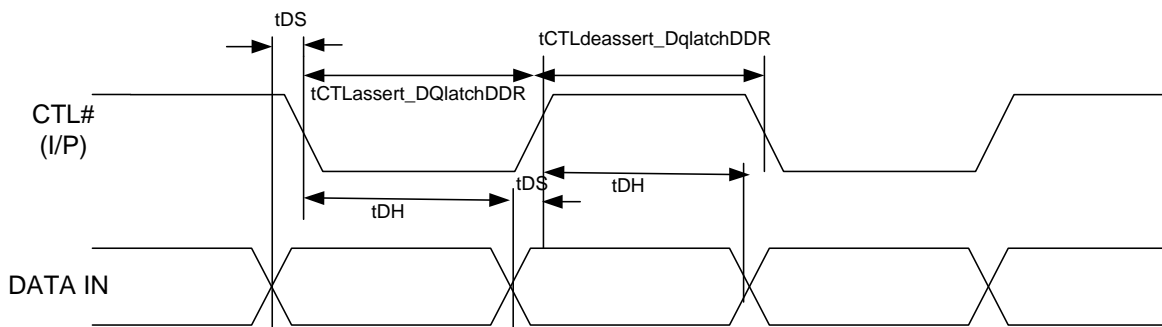

Table 9. GPIF II Timing in Asynchronous Mode^[4]

Note The following parameters assume one state transition

Parameter	Description	Min	Max	Units	Notes
tDS	Data In to DLE setup time. Valid in DDR async also.	2.3	–	ns	
tDH	Data In to DLE hold time. Valid in DDR async mode.	2	–	ns	
tAS	Address In to ALE setup time	2.3	–	ns	
tAH	Address In to ALE hold time	2	–	ns	
tCTLassert	CTL I/O asserted width for CTRL inputs without DQ input association and for outputs.	7	–	ns	
tCTLdeassert	CTL I/O deasserted width for CTRL inputs without DQ input association and for outputs.	7	–	ns	
tCTLassert_DQassert	CTL asserted pulse width for CTL inputs that signify DQ inputs valid at the asserting edge but do not employ in-built latches (ALE/DLE) for those DQ inputs.	20	–	ns	
tCTLdeassert_DQassert	CTL deasserted pulse width for CTL inputs that signify DQ input valid at the asserting edge but do not employ in-built latches (ALE/DLE) for those DQ inputs.	7	–	ns	
tCTLassert_DQdeassert	CTL asserted pulse width for CTL inputs that signify DQ inputs valid at the de-asserting edge but do not employ in-built latches (ALE/DLE) for those DQ inputs.	7	–	ns	
tCTLdeassert_DQdeassert	CTL deasserted pulse width for CTL inputs that signify DQ inputs valid at the deasserting edge but do not employ in-built latches (ALE/DLE) for those DQ inputs.	20	–	ns	
tCTLassert_DQlatch	CTL asserted pulse width for CTL inputs that employ in-built latches (ALE/DLE) to latch the DQ inputs. In this non_DDR case, in-built latches always close at the de-asserting edge.	7	–	ns	
tCTLdeassert_DQlatch	CTL deasserted pulse width for CTL inputs that employ in-built latches (ALE/DLE) to latch the DQ inputs. In this non-DDR case, in-built latches always close at the de-asserting edge.	10	–	ns	
tCTLassert_DQlatchDDR	CTL asserted pulse width for CTL inputs that employ in-built latches (DLE) to latch the DQ inputs in DDR mode.	10	–	ns	
tCTLdeassert_DQlatchDDR	CTL deasserted pulse width for CTL inputs that employ in-built latches (DLE) to latch the DQ inputs in DDR mode.	10	–	ns	
tGRANULARITY	Granularity of tCTLassert/tCTLdeassert for all outputs	5	–	ns	At 200 MHz internal clock
tAA	DQ/CTL input to DQ output time when DQ change or CTL change needs to be detected and affects internal updates of input and output DQ lines.	–	30	ns	
tDO	CTL to data out when the CTL change merely enables the output flop update whose data was already established.	–	25	ns	

Note

4. All parameters guaranteed by design and validated through characterization.

Table 9. GPIF II Timing in Asynchronous Mode^[4] (continued)

Note The following parameters assume one state transition

Parameter	Description	Min	Max	Units	Notes
tOELZ	CTL designated as OE to low-Z. Time when external devices should stop driving data.	0	–	ns	
tOEHZ	CTL designated as OE to High-Z	8	8	ns	
tCLZ	CTL (non OE) to Low-Z. Time when external devices should stop driving data.	0	–	ns	
tCHZ	CTL (non OE) to High-Z	30	30	ns	
tCTLalpha	CTL to alpha change at output	–	25	ns	
tCTLbeta	CTL to Beta change at output	–	30	ns	
tDST	Addr/data setup when DLE/ALE not used	2	–	ns	
tDHT	Addr/data hold when DLE/ALE not used	20	–	ns	

Slave FIFO Interface

Synchronous Slave FIFO Timing

Figure 10. Synchronous Slave FIFO Read Mode

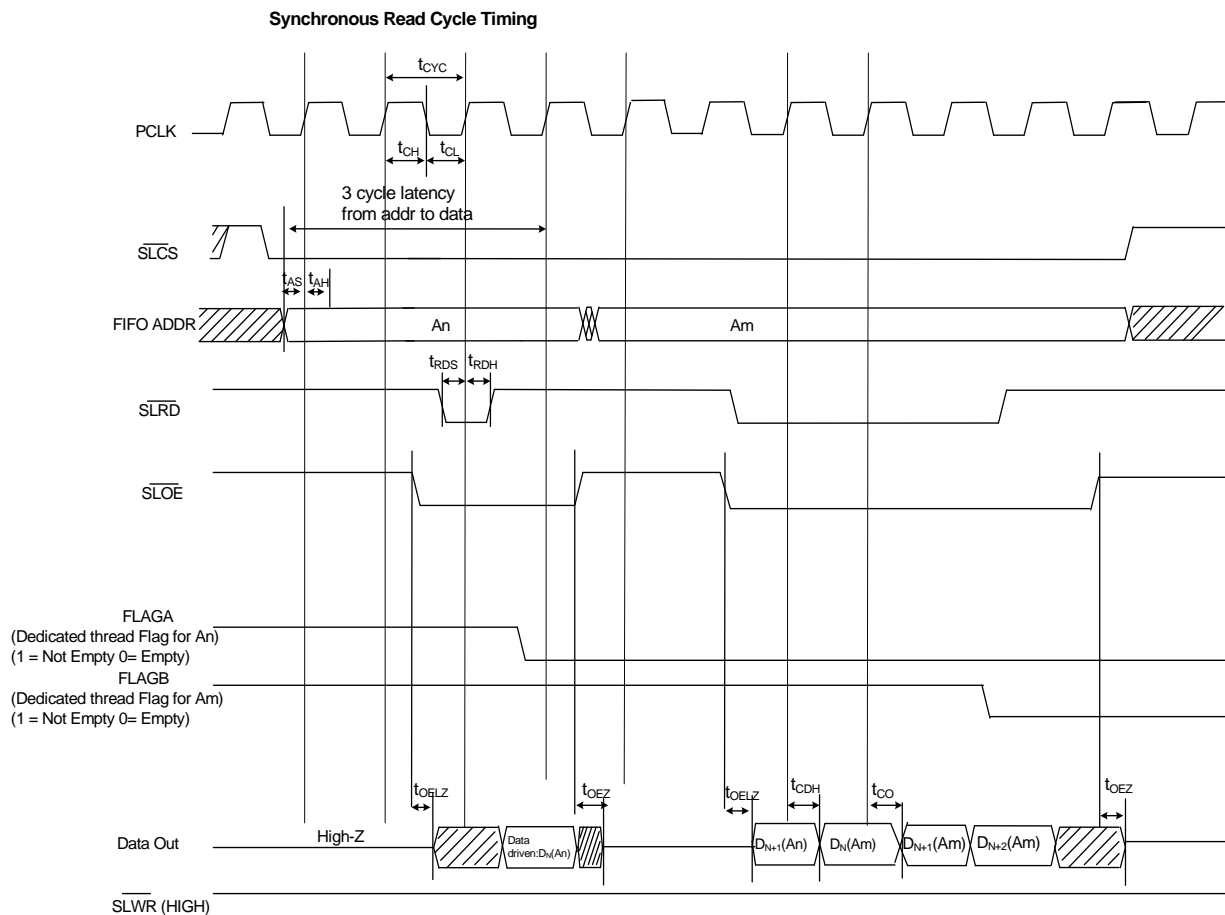

Synchronous Slave FIFO sequence description:

1. FIFO address is stable and SLCS is asserted
2. SLOE is asserted. SLOE is an output enable only, whose sole function is to drive the data bus.
3. SLRD is asserted
4. The FIFO pointer is updated on the rising edge of the PCLK, while the SLRD is asserted. This starts the propagation of data from the newly addressed location to the data bus. After a propagation delay of t_{co} (measured from the rising edge of PCLK) the new data value is present. N is the first data value read from the FIFO. To have data on the FIFO data bus, SLOE must also be asserted.

The same sequence of events is shown for a burst read.

Note For burst mode, the SLRD# and SLOE# are left asserted during the entire duration of the read. When SLOE# is asserted, the data bus is driven (with data from the previously addressed FIFO). For each subsequent rising edge of PCLK, while the SLRD# is asserted, the FIFO pointer is incremented and the next data value is placed on the data bus.

Figure 11. Synchronous Slave FIFO Write Mode

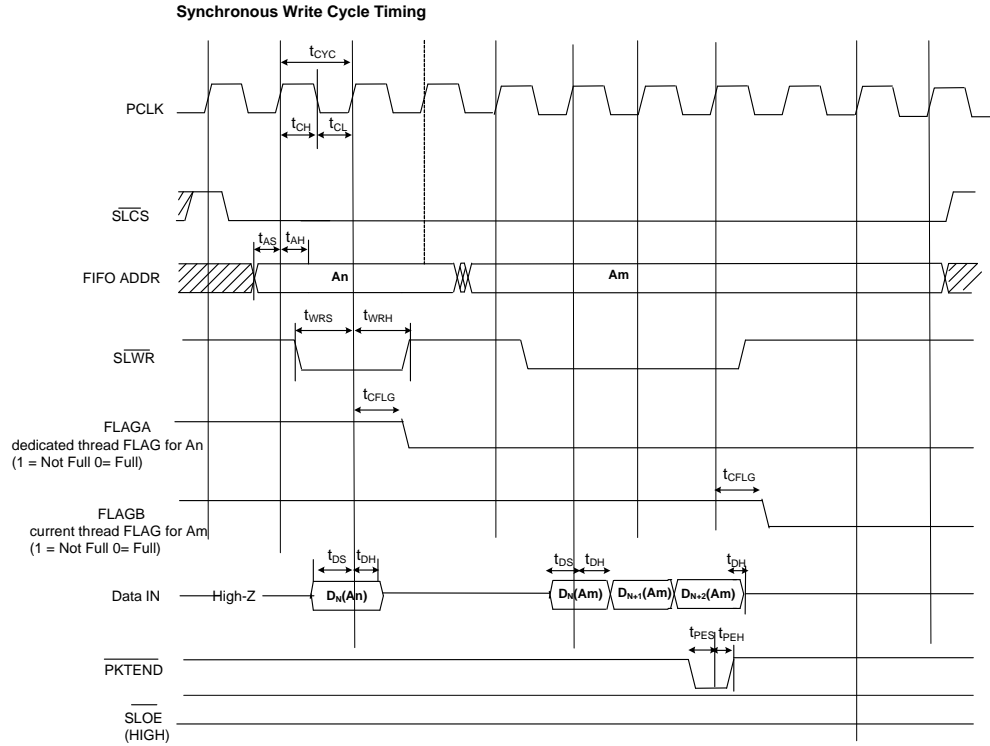

Synchronous ZLP Write Cycle Timing

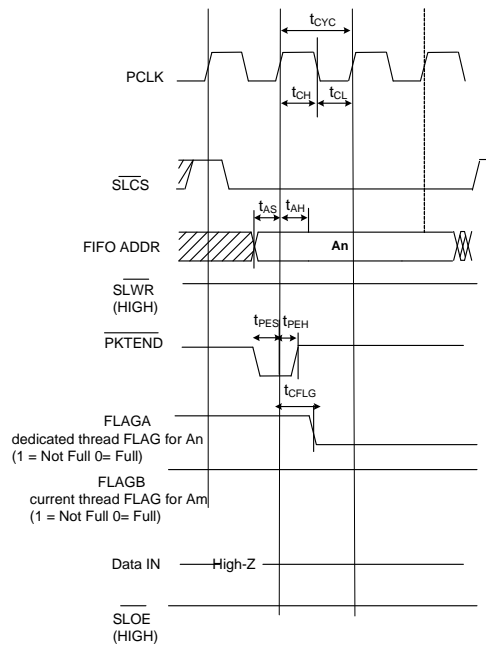

Synchronous Slave FIFO Write Sequence Description

- FIFO address is stable and the signal SLCS# is asserted
- External master/peripheral outputs the data onto the data bus
- SLWR# is asserted
- While the SLWR# is asserted, data is written to the FIFO and on the rising edge of the PCLK, the FIFO pointer is incremented
- The FIFO flag is updated after a delay of t_{WFLG} from the rising edge of the clock

The same sequence of events is also shown for burst write

Note: For the burst mode, SLWR# and SLCS# are left asserted for the entire duration of writing all the required data values. In this burst write mode, after the SLWR# is asserted, the data on

the FIFO data bus is written to the FIFO on every rising edge of PCLK. The FIFO pointer is updated on each rising edge of PCLK.

Short Packet: A short packet can be committed to the USB host by using the PKTEND#. The external device/processor should be designed to assert the PKTEND# along with the last word of data and SLWR# pulse corresponding to the last word. The FIFOADDR lines have to be held constant during the PKTEND# assertion.

Zero Length Packet: The external device/processor can signal a Zero Length Packet (ZLP) to EZ-USB FX3, simply by asserting PKTEND#, without asserting SLWR#. SLCS# and address must be driven as shown in the above timing diagram.

FLAG Usage: The FLAG signals are monitored by the external processor for flow control. FLAG signals are outputs from EZ-USB FX3 that may be configured to show empty/full/partial status for a dedicated thread or the current thread being addressed.

Table 10. Synchronous Slave FIFO Parameters^[5]

Parameter	Description	Min	Max	Units
FREQ	Interface clock frequency	–	100	MHz
tCYC	Clock period	10	–	ns
tCH	Clock high time	4	–	ns
tCL	Clock low time	4	–	ns
tRDS	SLRD# to CLK setup time	2	–	ns
tRDH	SLRD# to CLK hold time	0.5	–	ns
tWRS	SLWR# to CLK setup time	2	–	ns
tWRH	SLWR# to CLK hold time	0.5	–	ns
tCO	Clock to valid data	–	8	ns
tDS	Data input setup time	2	–	ns
tDH	CLK to data input hold	0.5	–	ns
tAS	Address to CLK setup time	2	–	ns
tAH	CLK to address hold time	0.5	–	ns
tOELZ	SLOE# to data low-Z	0	–	ns
tCFLG	CLK to flag output propagation delay	–	8	ns
tOEZ	SLOE# deassert to Data Hi Z	–	8	ns
tPES	PKTEND# to CLK setup	2	–	ns
tPEH	CLK to PKTEND# hold	0.5	–	
tCDH	CLK to data output hold	2	–	ns

Note Three-cycle latency from ADDR to DATA/FLAGS

Note

5. All parameters guaranteed by design and validated through characterization.

Asynchronous Slave FIFO Timing

Figure 12. Asynchronous Slave FIFO Read Mode

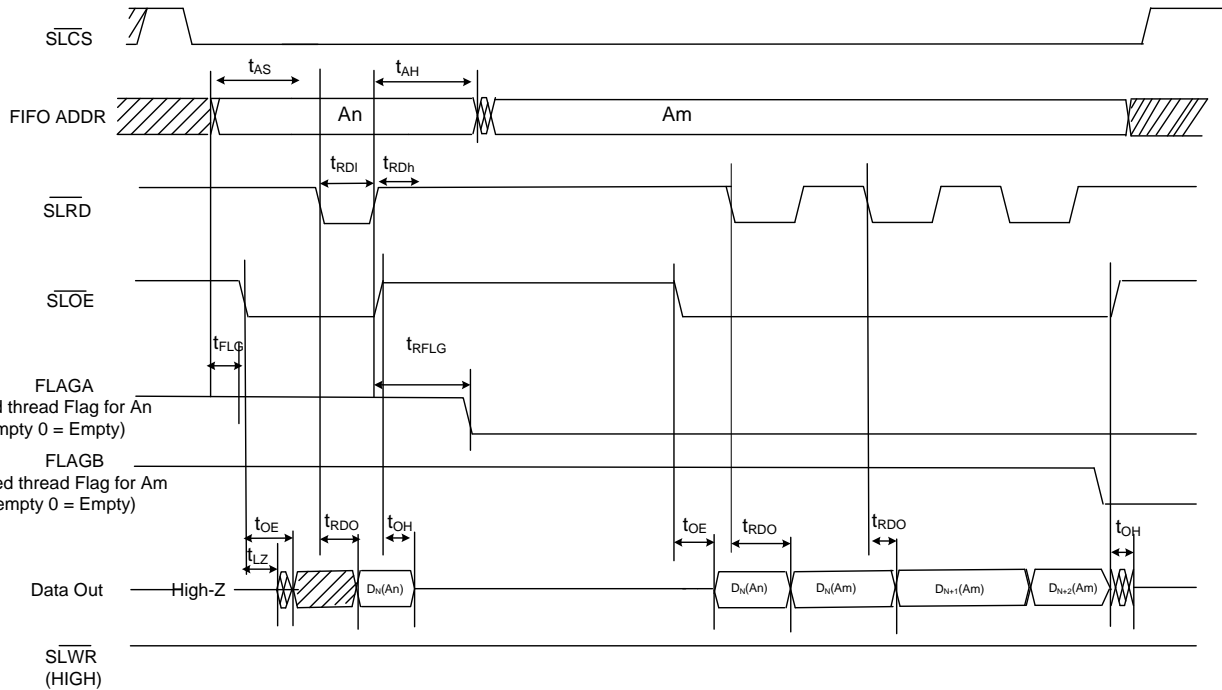

Asynchronous Slave FIFO Read Sequence Description

- FIFO address is stable and the SLCS# signal is asserted.
- SLOE# is asserted. This results in the data bus being driven.
- SLRD # is asserted.
- Data from the FIFO is driven on assertion of SLRD#. This data is valid after a propagation delay of t_{RDO} from the falling edge of SLRD#.
- FIFO pointer is incremented on de-assertion of SLRD#

In the above diagram, data N is the first valid data read from the FIFO. For data to appear on the data bus during the read cycle SLOE# must be in an asserted state. SLRD# and SLOE# can also be tied together.

The same sequence of events is also shown for a burst read.

Note: In burst read mode, during SLOE# assertion, the data bus is in a driven state (data driven is from previously addressed FIFO). On assertion of SLRD# data from the FIFO is driven on the data bus (SLOE# must also be asserted) and the FIFO pointer is incremented on de-assertion of SLRD#.

Figure 13. Asynchronous Slave FIFO Write Mode

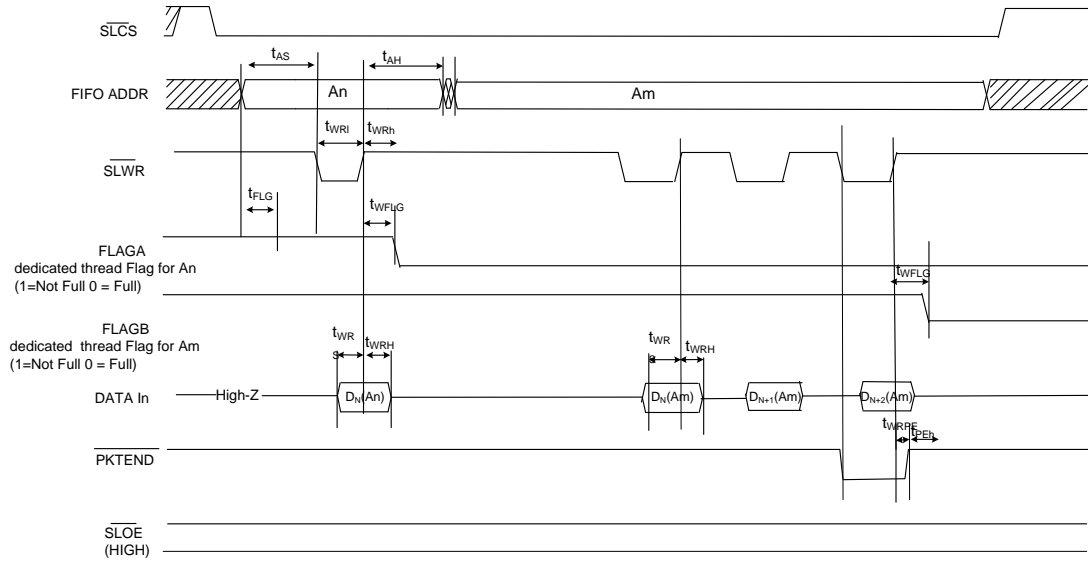

Change t_{WRPE} definition to $\overline{\text{SLWR}}$ de-assert to PKTEND de-assert = 0ns min (This means that PKTEND should not be deasserted before $\overline{\text{SLWR}}$)
 Note: PKTEND must be asserted at the same time as $\overline{\text{SLWR}}$.

Asynchronous ZLP Write Cycle Timing

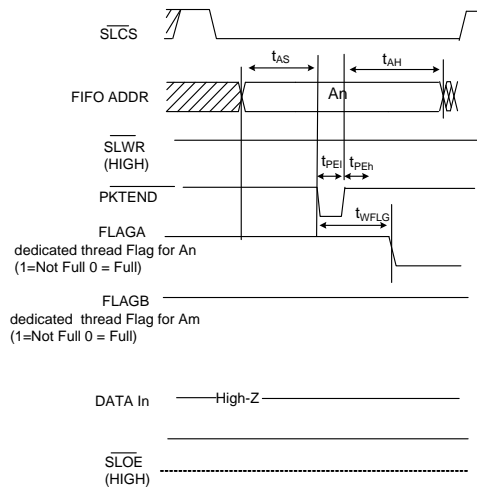

Asynchronous Slave FIFO Write Sequence Description

- FIFO address is driven and SLCS# is asserted
- SLWR# is asserted. SLCS# must be asserted with SLWR# or before SLWR# is asserted
- Data must be present on the bus tWRS before the deasserting edge of SLWR#
- De-assertion of SLWR# causes the data to be written from the data bus to the FIFO and then FIFO pointer is incremented
- The FIFO flag is updated after the tWFLG from the de-asserting edge of SLWR#.

The same sequence of events is shown for a burst write.

Note that in the burst write mode, on SLWR# de-assertion, the data is written to the FIFO and then the FIFO pointer is incremented.

Short Packet: A short packet can be committed to the USB host by using the PKTEND#. The external device/processor should be designed to assert the PKTEND# along with the last word of data and SLWR# pulse corresponding to the last word. The FIFOADDR lines have to be held constant during the PKTEND# assertion.

Zero Length Packet: The external device/processor can signal a Zero Length Packet (ZLP) to EZ-USB FX3, simply by asserting PKTEND#, without asserting SLWR#. SLCS# and address must be driven as shown in the above timing diagram.

FLAG Usage: The FLAG signals are monitored by the external processor for flow control. FLAG signals are outputs from EZ-USB FX3 that may be configured to show empty/full/partial status for a dedicated address or the current address.

Table 11. Asynchronous Slave FIFO Parameters^[6]

Parameter	Description	Min	Max	Units
tRDI	SLRD# low	20	–	ns
tRDh	SLRD# high	10	–	ns
tAS	Address to SLRD#/SLWR# setup time	7	–	ns
tAH	SLRD#/SLWR#/PKTEND to address hold time	2	–	ns
tRFLG	SLRD# to FLAGS output propagation delay	–	35	ns
tFLG	ADDR to FLAGS output propagation delay		22.5	
tRDO	SLRD# to data valid	–	25	ns
tOE	OE# low to data valid	–	25	ns
tLZ	OE# low to data low-Z	0	–	ns
tOH	SLOE# deassert data output hhold	–	22.5	ns
tWRI	SLWR# low	20	–	ns
tWRh	SLWR# high	10	–	ns
tWRS	Data to SLWR# setup time	7	–	ns
tWRH	SLWR# to Data Hold time	2	–	ns
tWFLG	SLWR#/PKTEND to Flags output propagation delay	–	35	ns
tPEI	PKTEND low	7.5	–	ns
tPEh	PKTEND high	7.5	–	ns
tWRPE	SLWR# deassert to PKTEND deassert	0	–	

Note

6. All parameters guaranteed by design and validated through characterization.

Serial Peripherals Timing

I²C Timing

Figure 14. I²C Timing Definition

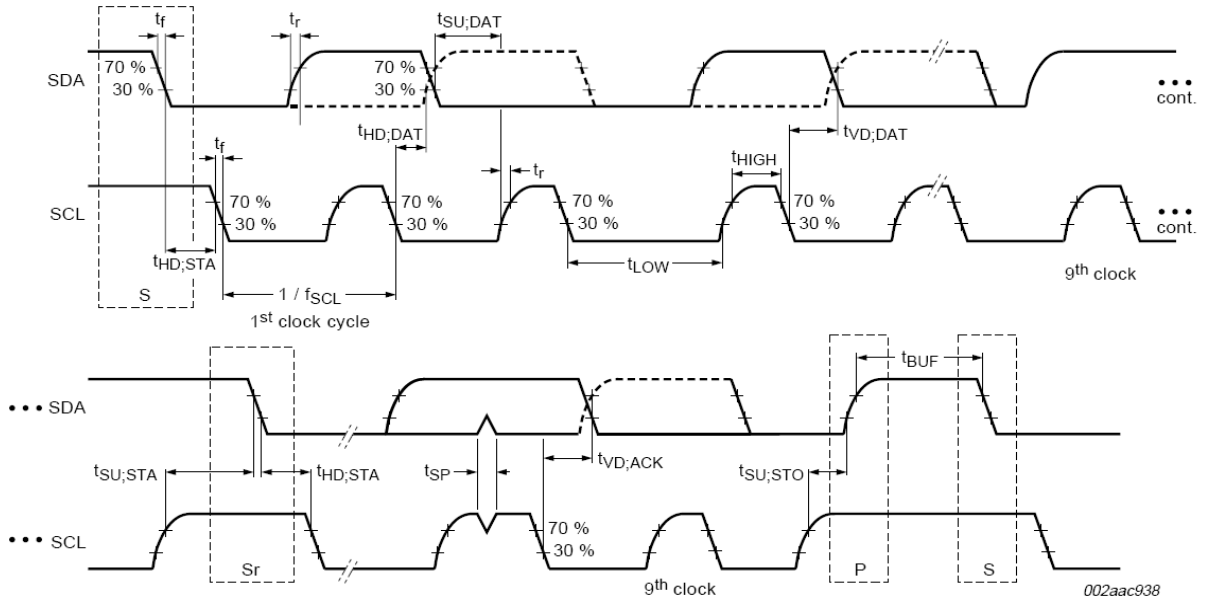

Table 12. I²C Timing Parameters^[7]

Parameter	Description	Min	Max	Units	Notes
I²C Standard Mode Parameters					
fSCL	SCL clock frequency	0	100	kHz	
tHD:STA	Hold time START condition	4	–	µs	
tLOW	LOW period of the SCL	4.7	–	µs	
tHIGH	HIGH period of the SCL	4	–	µs	
tSU:STA	Setup time for a repeated START condition	4.7	–	µs	
tHD:DAT	Data hold time	0	–	µs	
tSU:DAT	Data setup time	250	–	ns	
tr	Rise time of both SDA and SCL signals	–	1000	ns	
tf	Fall time of both SDA and SCL signals	–	300	ns	
tSU:STO	Setup time for STOP condition	4	–	µs	
tBUF	Bus free time between a STOP and START condition	4.7	–	µs	
tVD:DAT	Data valid time	–	3.45	µs	
tVD:ACK	Data valid ACK	–	3.45	µs	
tSP	Pulse width of spikes that must be suppressed by input filter	n/a	n/a		
I²C Fast Mode Parameters					
fSCL	SCL clock frequency	0	400	kHz	
tHD:STA	Hold time START condition	0.6	–	µs	
tLOW	LOW period of the SCL	1.3	–	µs	
tHIGH	HIGH period of the SCL	0.6	–	µs	
tSU:STA	Setup time for a repeated START condition	0.6	–	µs	
tHD:DAT	Data hold time	0	–	µs	
tSU:DAT	Data setup time	100	–	ns	
tr	Rise time of both SDA and SCL signals	–	300	ns	
tf	Fall time of both SDA and SCL signals	–	300	ns	
tSU:STO	Setup time for STOP condition	0.6	–	µs	
tBUF	Bus free time between a STOP and START condition	1.3	–	µs	
tVD:DAT	Data valid time	–	0.9	µs	
tVD:ACK	Data valid ACK	–	0.9	µs	
tSP	Pulse width of spikes that must be suppressed by input filter	0	50	ns	
I²C Fast Mode Plus Parameters (Not supported at I2C_VDDQ=1.2V)					
fSCL	SCL clock frequency	0	1000	kHz	
tHD:STA	Hold time START condition	0.26	–	µs	
tLOW	LOW period of the SCL	0.5	–	µs	
tHIGH	HIGH period of the SCL	0.26	–	µs	
tSU:STA	Setup time for a repeated START condition	0.26	–	µs	
tHD:DAT	Data hold time	0	–	µs	
tSU:DAT	Data setup time	50	–	ns	
tr	Rise time of both SDA and SCL signals	–	120	ns	
tf	Fall time of both SDA and SCL signals	–	120	ns	
tSU:STO	Setup time for STOP condition	0.26	–	µs	
tBUF	Bus free time between a STOP and START condition	0.5	–	µs	
tVD:DAT	Data valid time	–	0.45	µs	
tVD:ACK	Data valid ACK	–	0.45	µs	
tSP	Pulse width of spikes that must be suppressed by input filter	0	50	ns	

Note

7. All parameters guaranteed by design and validated through characterization.

I²S Timing Diagram

Figure 15. I²S Transmit Cycle

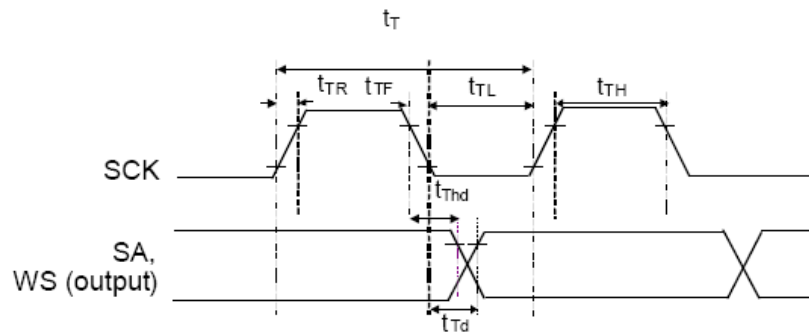

Table 13. I²S Timing Parameters^[8]

Parameter	Description	Min	Max	Units
t_T	I ² S transmitter clock cycle	T_{tr}	–	ns
t_{TL}	I ² S transmitter cycle LOW period	$0.35 T_{tr}$	–	ns
t_{TH}	I ² S transmitter cycle HIGH period	$0.35 T_{tr}$	–	ns
t_{TR}	I ² S transmitter rise time	–	$0.15 T_{tr}$	ns
t_{TF}	I ² S transmitter fall time	–	$0.15 T_{tr}$	ns
t_{Thd}	I ² S transmitter data hold time	0	–	ns
t_{Td}	I ² S transmitter delay time	–	$0.3t_T$	ns

Note t_T is selectable through clock gears. Max T_{tr} is designed for 96 kHz codec at 32 bits to be 326 ns (3.072 MHz).

Note

8. All parameters guaranteed by design and validated through characterization.

SPI Timing Specification

Figure 16. SPI Timing

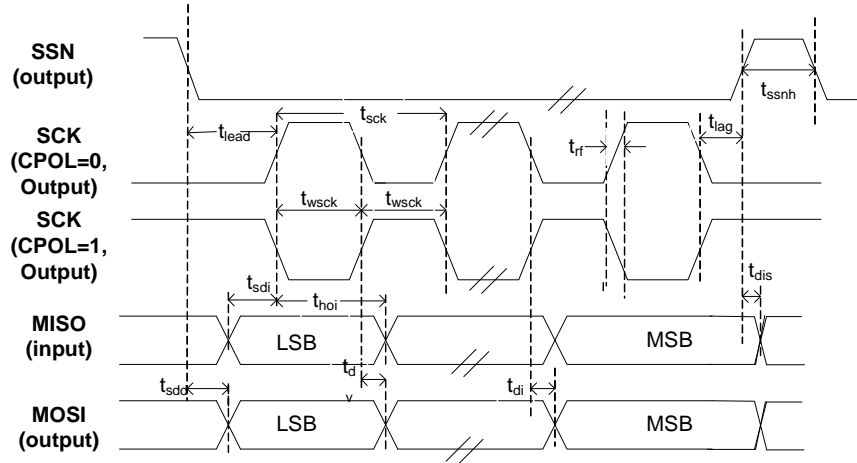

SPI Master Timing for CPHA = 0

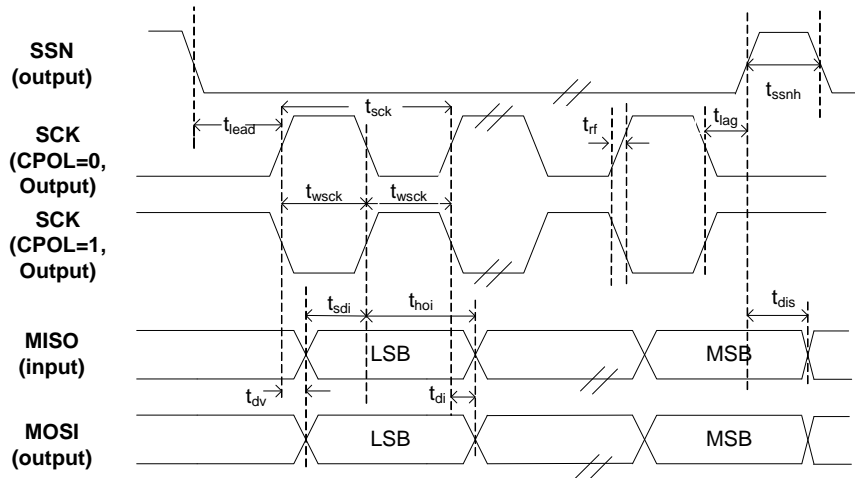

SPI Master Timing for CPHA = 1

Table 14. SPI Timing Parameters^[9]

Parameter	Description	Min	Max	Units
fop	Operating frequency	0	33	MHz
tsck	Cycle time	30	–	ns
twscck	Clock high/low time	13.5	–	ns
tlead	SSN-SCK lead time	$1/2 \text{ tsck}^{[10]} - 5$	$1.5 \text{ tsck}^{[10]} + 5$	ns
tlag	Enable lag time	0.5	$1.5 \text{ tsck}^{[10]} + 5$	ns
trf	Rise/fall time	–	8	ns
tsdd	Output SSN to valid data delay time	–	5	ns
tdv	Output data valid time	–	5	ns
tdi	Output data invalid	0	–	ns
tssnh	Minimum SSN high time	10	–	ns
tsdi	Data setup time input	8	–	ns
thoi	Data hold time input	0	–	ns
tdis	Disable data output on SSN high	0	–	ns

Reset Sequence

The hard reset sequence requirements for EZ-USB FX3 are specified here.

Table 15. Reset and Standby Timing Parameters

Parameter	Definition	Conditions	Min (ms)	Max (ms)
tRPW	Minimum RESET# pulse width	Clock Input	1	–
		Crystal Input	5	–
tRH	Minimum high on RESET#	–	5	–
tRR	Reset recovery time (after which Boot loader begins firmware download)	–	1	–
tSBY	Time to enter standby/suspend (from the time MAIN_CLOCK_EN/ MAIN_POWER_EN bit is set)	–	–	1
tWU	Time to wakeup from standby	Clock Input	1	–
		Crystal Input	5	–
tWH	Minimum time before Standby/Suspend source may be reasserted	–	5	–

Notes

- 9. All parameters guaranteed by design and validated through characterization.
- 10. Depends on LAG and LEAD setting in SPI_CONFIG register.

Figure 17. Reset Sequence

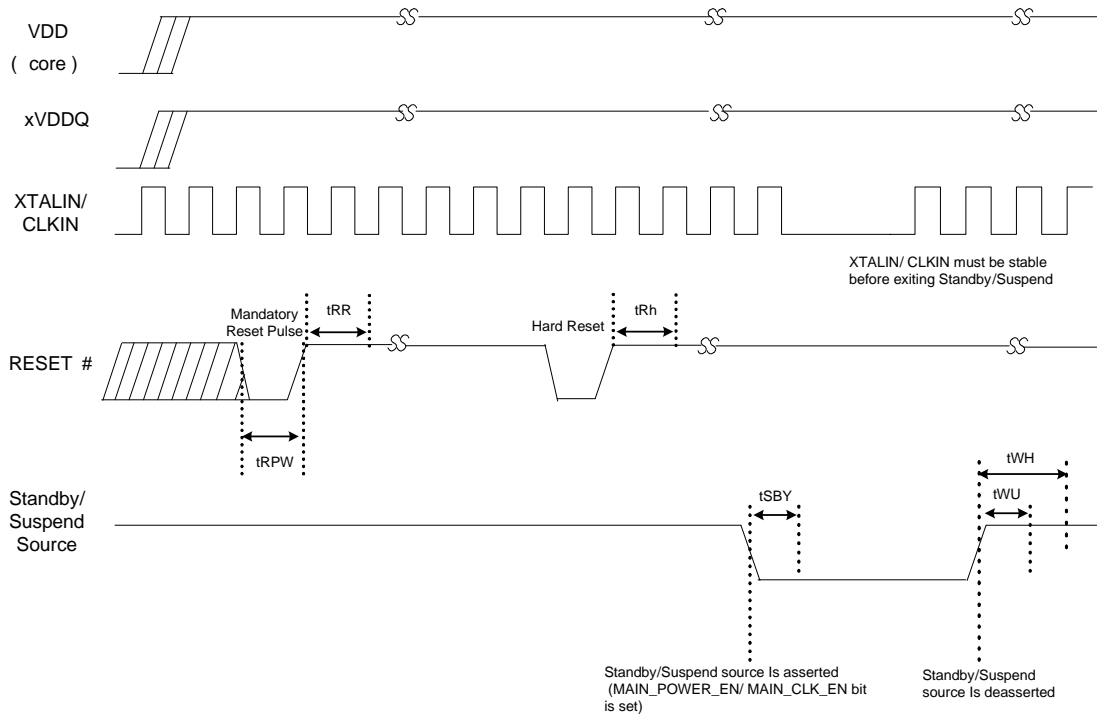

Ball Map

Figure 18. Ball Map for EZ-USB FX3 (Top View)

	1	2	3	4	5	6	7	8	9	10	11
A	U3VSSQ	U3RXVDDQ	SSRXM	SSRXP	SSTXP	SSTXM	AVDD	VSS	DP	DM	NC
B	VIO4	FSLC[0]	R_USB3	FSLC[1]	U3TXVDDQ	CVDDQ	AVSS	VSS	VSS	VDD	TRST#
C	GPIO[54]	GPIO[55]	VDD	GPIO[57]	RESET#	XTALIN	XTALOUT	R_USB2	OTG_ID	TDO	VIO5
D	GPIO[50]	GPIO[51]	GPIO[52]	GPIO[53]	GPIO[56]	CLKIN_32	CLKIN	VSS	I2C_GPIO[58]	I2C_GPIO[59]	O[60]
E	GPIO[47]	VSS	VIO3	GPIO[49]	GPIO[48]	FSLC[2]	TDI	TMS	VDD	VBATT	VBUS
F	VIO2	GPIO[45]	GPIO[44]	GPIO[41]	GPIO[46]	TCK	GPIO[2]	GPIO[5]	GPIO[1]	GPIO[0]	VDD
G	VSS	GPIO[42]	GPIO[43]	GPIO[30]	GPIO[25]	GPIO[22]	GPIO[21]	GPIO[15]	GPIO[4]	GPIO[3]	VSS
H	VDD	GPIO[39]	GPIO[40]	GPIO[31]	GPIO[29]	GPIO[26]	GPIO[20]	GPIO[24]	GPIO[7]	GPIO[6]	VIO1
J	GPIO[38]	GPIO[36]	GPIO[37]	GPIO[34]	GPIO[28]	GPIO[16]	GPIO[19]	GPIO[14]	GPIO[9]	GPIO[8]	VDD
K	GPIO[35]	GPIO[33]	VSS	VSS	GPIO[27]	GPIO[23]	GPIO[18]	GPIO[17]	GPIO[13]	GPIO[12]	GPIO[10]
L	VSS	VSS	VSS	GPIO[32]	VDD	VSS	VDD	INT#	VIO1	GPIO[11]	VSS

Pin Description

Table 16. Pin List

Pin	I/O	Name	Description		
			GPIFII (VIO1 Power Domain)		
			GPIF™II Interface		Slave FIFO Interface
F10	VIO1	I/O	GPIO[0]	DQ[0]	DQ[0]
F9	VIO1	I/O	GPIO[1]	DQ[1]	DQ[1]
F7	VIO1	I/O	GPIO[2]	DQ[2]	DQ[2]
G10	VIO1	I/O	GPIO[3]	DQ[3]	DQ[3]
G9	VIO1	I/O	GPIO[4]	DQ[4]	DQ[4]
F8	VIO1	I/O	GPIO[5]	DQ[5]	DQ[5]
H10	VIO1	I/O	GPIO[6]	DQ[6]	DQ[6]
H9	VIO1	I/O	GPIO[7]	DQ[7]	DQ[7]
J10	VIO1	I/O	GPIO[8]	DQ[8]	DQ[8]
J9	VIO1	I/O	GPIO[9]	DQ[9]	DQ[9]
K11	VIO1	I/O	GPIO[10]	DQ[10]	DQ[10]
L10	VIO1	I/O	GPIO[11]	DQ[11]	DQ[11]
K10	VIO1	I/O	GPIO[12]	DQ[12]	DQ[12]
K9	VIO1	I/O	GPIO[13]	DQ[13]	DQ[13]
J8	VIO1	I/O	GPIO[14]	DQ[14]	DQ[14]
G8	VIO1	I/O	GPIO[15]	DQ[15]	DQ[15]
J6	VIO1	I/O	GPIO[16]	PCLK	CLK
K8	VIO1	I/O	GPIO[17]	CTL[0]	SLCS#
K7	VIO1	I/O	GPIO[18]	CTL[1]	SLWR#
J7	VIO1	I/O	GPIO[19]	CTL[2]	SLOE#
H7	VIO1	I/O	GPIO[20]	CTL[3]	SLRD#
G7	VIO1	I/O	GPIO[21]	CTL[4]	FLAGA
G6	VIO1	I/O	GPIO[22]	CTL[5]	FLAGB
K6	VIO1	I/O	GPIO[23]	CTL[6]	GPIO
H8	VIO1	I/O	GPIO[24]	CTL[7]	PKTEND#
G5	VIO1	I/O	GPIO[25]	CTL[8]	GPIO
H6	VIO1	I/O	GPIO[26]	CTL[9]	GPIO
K5	VIO1	I/O	GPIO[27]	CTL[10]	GPIO
J5	VIO1	I/O	GPIO[28]	CTL[11]	A1
H5	VIO1	I/O	GPIO[29]	CTL[12]	A0
G4	VIO1	I/O	GPIO[30]	PMODE[0]	PMODE[0]
H4	VIO1	I/O	GPIO[31]	PMODE[1]	PMODE[1]
L4	VIO1	I/O	GPIO[32]	PMODE[2]	PMODE[2]
L8	VIO1	I/O	INT#	INT#/CTL[15]	CTL[15]
C5	CVDDQ	I	RESET#	RESET#	RESET#
			IO2 (VIO2 Power Domain)		
			GPIF II (32-bit data mode)		
K2	VIO2	I/O	GPIO[33]	DQ[16]	GPIO
J4	VIO2	I/O	GPIO[34]	DQ[17]	GPIO
K1	VIO2	I/O	GPIO[35]	DQ[18]	GPIO
J2	VIO2	I/O	GPIO[36]	DQ[19]	GPIO
J3	VIO2	I/O	GPIO[37]	DQ[20]	GPIO

Table 16. Pin List (continued)

Pin		I/O	Name	Description					
J1	VIO2	I/O	GPIO[38]	DQ[21]			GPIO		
H2	VIO2	I/O	GPIO[39]	DQ[22]			GPIO		
H3	VIO2	I/O	GPIO[40]	DQ[23]			GPIO		
F4	VIO2	I/O	GPIO[41]	DQ[24]			GPIO		
G2	VIO2	I/O	GPIO[42]	DQ[25]			GPIO		
G3	VIO2	I/O	GPIO[43]	DQ[26]			GPIO		
F3	VIO2	I/O	GPIO[44]	DQ[27]			GPIO		
F2	VIO2	I/O	GPIO[45]	GPIO					
IO3 (VIO3 Power Domain)									
							GPIF II - 32 (FX3)+UART+I2S	GPIO+I2S	UART+SPI+I2S
F5	VIO3	I/O	GPIO[46]	GPIO	GPIO	GPIO	DQ[28]	GPIO	UART_RTS
E1	VIO3	I/O	GPIO[47]	GPIO	GPIO	GPIO	DQ[29]	GPIO	UART_CTS
E5	VIO3	I/O	GPIO[48]	GPIO	GPIO	GPIO	DQ[30]	GPIO	UART_TX
E4	VIO3	I/O	GPIO[49]	GPIO	GPIO	GPIO	DQ[31]	GPIO	UART_RX
D1	VIO3	I/O	GPIO[50]	GPIO	GPIO	GPIO	I2S_CLK	GPIO	I2S_CLK
D2	VIO3	I/O	GPIO[51]	GPIO	GPIO	GPIO	I2S_SD	GPIO	I2S_SD
D3	VIO3	I/O	GPIO[52]	GPIO	GPIO	GPIO	I2S_WS	GPIO	I2S_WS
IO4 (VIO4) Power Domain									
D4	VIO4	I/O	GPIO[53]	SPI_SCK	UART_RTS	GPIO	UART_RTS	GPIO	SPI_SCK
C1	VIO4	I/O	GPIO[54]	SPI_SSN	UART_CTS	GPIO	UART_CTS	I2S_CLK	SPI_SSN
C2	VIO4	I/O	GPIO[55]	SPI_MISO	UART_TX	GPIO	UART_TX	I2S_SD	SPI_MISO
D5	VIO4	I/O	GPIO[56]	SPI_MOSI	UART_RX	GPIO	UART_RX	I2S_WS	SPI_MOSI
C4	VIO4	I/O	GPIO[57]	GPIO	GPIO	GPIO	I2S_MCLK	I2S_MCLK	I2S_MCLK
USB Port (VBATT/VBUS Power Domain)									
C9	VBUS/ VBATT	I	OTG_ID	OTG_ID					
USB Port (U3TXVDDQ/U3RXVDDQ Power Domain)									
A3	U3RXVDDQ	I	SSRXM	SSRX-					
A4	U3RXVDDQ	I	SSRXP	SSRX+					
A6	U3TXVDDQ	O	SSTXM	SSTX-					
A5	U3TXVDDQ	O	SSTXP	SSTX+					
USB Port (VBATT/VBUS Power Domain)									
A9	VBUS/VBATT	I/O	DP	D+					
A10	VBUS/VBATT	I/O	DM	D-					
A11			NC	No connect					
Crystal/Clocks (CVDDQ Power Domain)									
B2	CVDDQ	I	FSLC[0]	FSLC[0]					
C6	AVDD	I/O	XTALIN	XTALIN					
C7	AVDD	I/O	XTALOUT	XTALOUT					
B4	CVDDQ	I	FSLC[1]	FSLC[1]					
E6	CVDDQ	I	FSLC[2]	FSLC[2]					
D7	CVDDQ	I	CLKIN	CLKIN					
D6	CVDDQ	I	CLKIN_32	CLKIN_32					
I2C and JTAG (VIO5 Power Domain)									
D9	VIO5	I/O	I2C_GPIO[58]	I ² C_SCL					
D10	VIO5	I/O	I2C_GPIO[59]	I ² C_SDA					

Table 16. Pin List (continued)

Pin		I/O	Name	Description
E7	VIO5	I	TDI	TDI
C10	VIO5	O	TDO	TDO
B11	VIO5	I	TRST#	TRST#
E8	VIO5	I	TMS	TMS
F6	VIO5	I	TCK	TCK
D11	VIO5	I/O	O[60]	Charger detect output
Power				
E10		PWR	VBATT	
B10		PWR	VDD	
A1		PWR	U3VSSQ	
E11		PWR	VBUS	
D8		PWR	VSS	
H11		PWR	VIO1	
E2		PWR	VSS	
L9		PWR	VIO1	
G1		PWR	VSS	
F1		PWR	VIO2	
G11		PWR	VSS	
E3		PWR	VIO3	
L1		PWR	VSS	
B1		PWR	VIO4	
L6		PWR	VSS	
B6		PWR	CVDDQ	
B5		PWR	U3TXVDDQ	
A2		PWR	U3RXVDDQ	
C11		PWR	VIO5	
L11		PWR	VSS	
A7		PWR	AVDD	
B7		PWR	AVSS	
C3		PWR	VDD	
B8		PWR	VSS	
E9		PWR	VDD	
B9		PWR	VSS	
F11		PWR	VDD	
H1		PWR	VDD	
L7		PWR	VDD	
J11		PWR	VDD	
L5		PWR	VDD	
K4		PWR	VSS	
L3		PWR	VSS	
K3		PWR	VSS	
L2		PWR	VSS	
A8		PWR	VSS	
Precision Resistors				
C8	VBUS/VBATT	I/O	R_usb2	Precision resistor for USB2.0 (Connect a 6.04 kΩ±1% resistor between this pin and GND)
B3	U3TXVDDQ	I/O	R_usb3	Precision resistor for USB3.0 (Connect a 200 Ω±1% resistor between this pin and GND)

Package Diagram

Figure 19. 121-Ball FBGA 10x10x1.2 Diagram

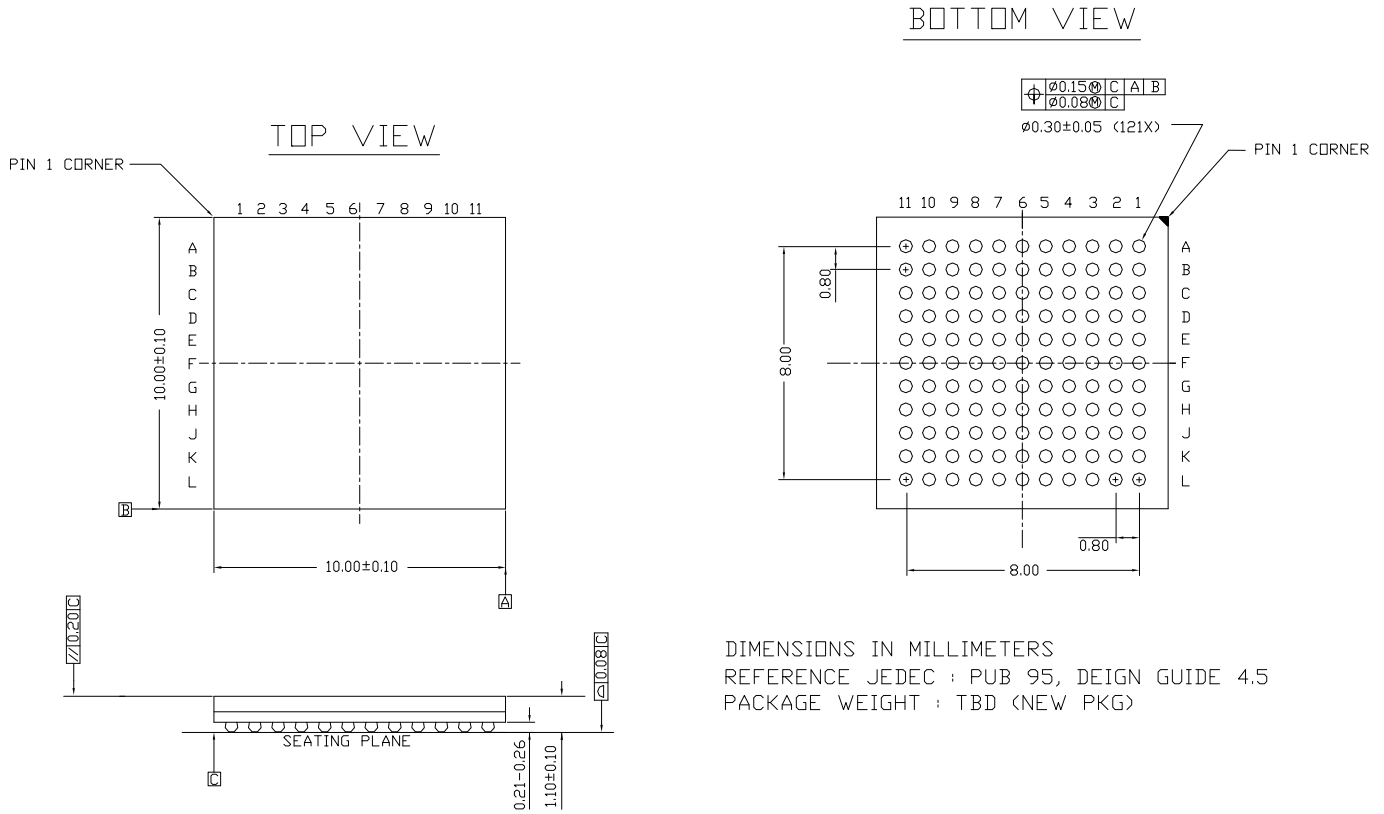

001-54471 *B

Ordering Information

Table 17. Ordering Information

Ordering Code	Package Type
CYUSB3014-BZXI	121-ball BGA

Ordering Code Definition

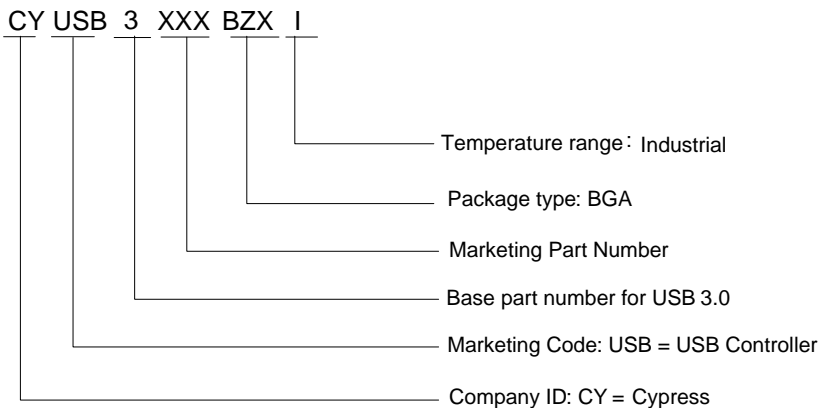

Acronyms

Acronym	Description
DMA	direct memory access
HNP	host negotiation protocol
MMC	multimedia card
MTP	media transfer protocol
PLL	phase locked loop
SD	secure digital
SD	secure digital
SDIO	secure digital input / output
SLC	single-level cell
SPI	serial peripheral interface
SRP	session request protocol
USB	universal serial bus
WLCSP	wafer level chip scale package

Document Conventions

Units of Measure

Symbol	Unit of Measure
°C	degree Celsius
μA	microamperes
μs	microseconds
mA	milliamperes
Mbps	Megabytes per second
MHz	mega hertz
ms	milliseconds
ns	nanoseconds
Ω	ohms
pF	pico Farad
V	volts

Document History Page

Document Title: CYUSB3014 EZ-USB [®] FX3 SuperSpeed USB Controller				
Document Number: 001-52136				
Revision	ECN	Orig. of Change	Submission Date	Description of Change
**	2669761	VSO/PYRS	03/06/09	New Datasheet
*A	2758370	VSO	09/01/09	<p>Updated the part# from CYX01XXBB to CYUSB3011-BZXI</p> <p>Changed the title from "ADVANCE" to "ADVANCE INFORMATION"</p> <p>In page 1, the second bullet (Flexible Host Interface), add "32-bit, 100 MHz" to first sub bullet.</p> <p>In page 1, changed the second bullet "Flexible Host Interface" to General Programmable Interface".</p> <p>In page 1, the second bullet (Flexible Host Interface), removed "DMA Slave Support" and "MMC Slave support with Pass through Boot" sub bullets.</p> <p>In page 1, third bullet, changed "50 μA with Core Power" to "60 μA with Core Power"</p> <p>In page 1, fifth bullet, added "at 1 MHz"</p> <p>In page 1, seventh bullet, added "up to 4MHz" to UART</p> <p>In page 1, Applications Section, move "Digital Still Cameras" to second line.</p> <p>In page 1, Applications Section, added "Machine Vision" and Industrial Cameras"</p> <p>Added [™] to GPIF and FX3.</p> <p>In page 1, updated Logic Block Diagram.</p> <p>In page 2, section of "Functional Overview", updated the whole section.</p> <p>In page 2, removed the section of "Product Interface"</p> <p>In page 2, removed the section of "Processor Interface (P-Port)"</p> <p>In page 2, removed the section of "USB Interface (U-Port)"</p> <p>In page 2, removed the section of "Other Interfaces"</p> <p>In page 2, added a section of "GPIF II"</p> <p>In page 2, added a section of "CPU"</p> <p>In page 2, added a section of "JTAG Interface"</p> <p>In page 2, added a section of "Boot Options"</p> <p>In page 2, added a section of "ReNumeration"</p> <p>In page 2, added a section of "Power"</p> <p>In the section of "Package", replaced "West Bridge USB 3.0 Platform" by FX3.</p> <p>In the section of "Package", added 0.8 mm pitch in front of BGA.</p> <p>Added Pin List (Table 1)</p>
*B	2779196	VSO/PYRS	09/29/09	<p>Features:</p> <p>Added the thrid bullet "Fully accessible 32-bit ARM9 core with 512kB of embedded SRAM"</p> <p>Added the thrid line "EZ USB[™] Software and DVK for easy code development"</p> <p>Table 1: Pin 74, corrected to NC - No Connect.</p> <p>Changed title to EZ-USB[™] FX3: SuperSpeed USB Controller</p>
*C	2823531	OSG	12/08/09	Added data sheet to the USB3.0 EROS spec 001-51884. No technical updates.
*D	3080927	OSG	11/08/2010	<p>Changed status from Advance to Preliminary</p> <p>Changed part number from CYUSB3011 to CYUSB3014</p> <p>Added the following sections: Power, Configuration Options, Digital I/Os, System Level ESD, Absolute Maximum Ratings, AC Timing Parameters, Reset Sequence, Package Diagram</p> <p>Added DC Specifications table</p> <p>Updated feature list</p> <p>Updated Pin List</p> <p>Added support for selectable clock input frequencies.</p> <p>Updated block diagram</p> <p>Updated part number</p> <p>Updated package diagram</p>

Document Title: CYUSB3014 EZ-USB® FX3 SuperSpeed USB Controller				
Document Number: 001-52136				
Revision	ECN	Orig. of Change	Submission Date	Description of Change
*E	3204393	OSG	03/24/2011	Updated Slave FIFO protocol and added ZLP signaling protocol Changed GPIFII asynchronous tDO parameter Changed Async Slave FIFO tOE parameter Changed Async Slave FIFO tRDO parameter Added tCOE parameter to GPIFII Sync mode timing parameters Renamed GPIFII Sync mode tDO to tCO and tDO_ss0 to tCO_ss0 Modified description of GPIFII Sync tCO (previously tDO) parameter Changed tAH(address hold time) parameter in Async Slave FIFO modes to be with respect to rising edge of SLWR#/SLRD# instead of falling edge. Correspondingly, changed the tAH number. Removed 24 bit data bus support for GPIFII.
*F	3219493	OSG	04/07/2011	Minor ECN - Release to web. No content changes.
*G	3235250	GSZ	04/20/2011	Minor updates in Features.
*H	3217917	OSG	04/06/2011	Updated GPIFII Synchronous Timing diagram. Added SPI Boot option. Corrected values of R_USB2 and R_USB3. Corrected TCK and TRST# pull-up/pull-down configuration. Minor updates to block diagrams. Corrected Synchronous Slave FIFO tDH parameter.
*I	3305568	DSG	07/07/2011	Minor ECN - Correct ECN number in revision *F. No content changes.

Sales, Solutions, and Legal Information

Worldwide Sales and Design Support

Cypress maintains a worldwide network of offices, solution centers, manufacturer’s representatives, and distributors. To find the office closest to you, visit us at [Cypress Locations](#).

Products

- Automotive cypress.com/go/automotive
- Clocks & Buffers cypress.com/go/clocks
- Interface cypress.com/go/interface
- Lighting & Power Control cypress.com/go/powerpsoc
cypress.com/go/plc
- Memory cypress.com/go/memory
- Optical & Image Sensing cypress.com/go/image
- PSoC cypress.com/go/psoc
- Touch Sensing cypress.com/go/touch
- USB Controllers cypress.com/go/USB
- Wireless/RF cypress.com/go/wireless

PSoC Solutions

- psoc.cypress.com/solutions
- PSoC 1 | PSoC 3 | PSoC 5

© Cypress Semiconductor Corporation, 2009-2011. The information contained herein is subject to change without notice. Cypress Semiconductor Corporation assumes no responsibility for the use of any circuitry other than circuitry embodied in a Cypress product. Nor does it convey or imply any license under patent or other rights. Cypress products are not warranted nor intended to be used for medical, life support, life saving, critical control or safety applications, unless pursuant to an express written agreement with Cypress. Furthermore, Cypress does not authorize its products for use as critical components in life-support systems where a malfunction or failure may reasonably be expected to result in significant injury to the user. The inclusion of Cypress products in life-support systems application implies that the manufacturer assumes all risk of such use and in doing so indemnifies Cypress against all charges.

Any Source Code (software and/or firmware) is owned by Cypress Semiconductor Corporation (Cypress) and is protected by and subject to worldwide patent protection (United States and foreign), United States copyright laws and international treaty provisions. Cypress hereby grants to licensee a personal, non-exclusive, non-transferable license to copy, use, modify, create derivative works of, and compile the Cypress Source Code and derivative works for the sole purpose of creating custom software and or firmware in support of licensee product to be used only in conjunction with a Cypress integrated circuit as specified in the applicable agreement. Any reproduction, modification, translation, compilation, or representation of this Source Code except as specified above is prohibited without the express written permission of Cypress.

Disclaimer: CYPRESS MAKES NO WARRANTY OF ANY KIND, EXPRESS OR IMPLIED, WITH REGARD TO THIS MATERIAL, INCLUDING, BUT NOT LIMITED TO, THE IMPLIED WARRANTIES OF MERCHANTABILITY AND FITNESS FOR A PARTICULAR PURPOSE. Cypress reserves the right to make changes without further notice to the materials described herein. Cypress does not assume any liability arising out of the application or use of any product or circuit described herein. Cypress does not authorize its products for use as critical components in life-support systems where a malfunction or failure may reasonably be expected to result in significant injury to the user. The inclusion of Cypress’ product in a life-support systems application implies that the manufacturer assumes all risk of such use and in doing so indemnifies Cypress against all charges.

Use may be limited by and subject to the applicable Cypress software license agreement.