

Programmable Radio on Chip Low Power

PROc™ LP Features

- **Single Device, Two Functions**
 - 8-bit Flash based MCU function and 2.4 GHz radio transceiver function in a single device.
- **Flash Based Microcontroller Function**
 - M8C based 8-bit CPU, optimized for Human Interface Devices (HID) applications
 - 256 Bytes of SRAM
 - 8 Kbytes of Flash memory with EEPROM emulation
 - In-System reprogrammable
 - CPU speed up to 12 MHz
 - 16-bit free running timer
 - Low power wakeup timer
 - 12-bit Programmable Interval Timer with interrupts
 - Watchdog timer
- **Industry leading 2.4 GHz Radio Transceiver Function**
 - Operates in the unlicensed worldwide Industrial, Scientific, and Medical (ISM) band (2.4 GHz to 2.483 GHz)
 - DSSS data rates of up to 250 Kbps
 - GFSK data rate of 1 Mbps
 - -97 dBm receive sensitivity
- Programmable output power up to +4 dBm
- Auto Transaction Sequencer (ATS)
- Framing CRC and Auto ACK
- Received Signal Strength Indication (RSSI)
- Automatic Gain Control (AGC)
- **Component Reduction**
 - Integrated 1.8 V boost converter
 - GPIOs that require no external components
 - Operates off a single crystal
- **Flexible I/O**
 - 2 mA source current on all GPIO pins. Configurable 8 mA or 50 mA/pin current sink on designated pins
 - Each GPIO pin supports high impedance inputs, configurable pull up, open drain output, CMOS/TTL inputs, and CMOS output
 - Maskable interrupts on all I/O pins
- **Operating Voltage from 1.8 V to 3.6 V DC**
- **Operating Temperature from 0 to 70 °C**
- **Pb-free 40-pin QFN Package**
- **Advanced Development Tools based on Cypress's PSoC® Tools**

Logic Block Diagram

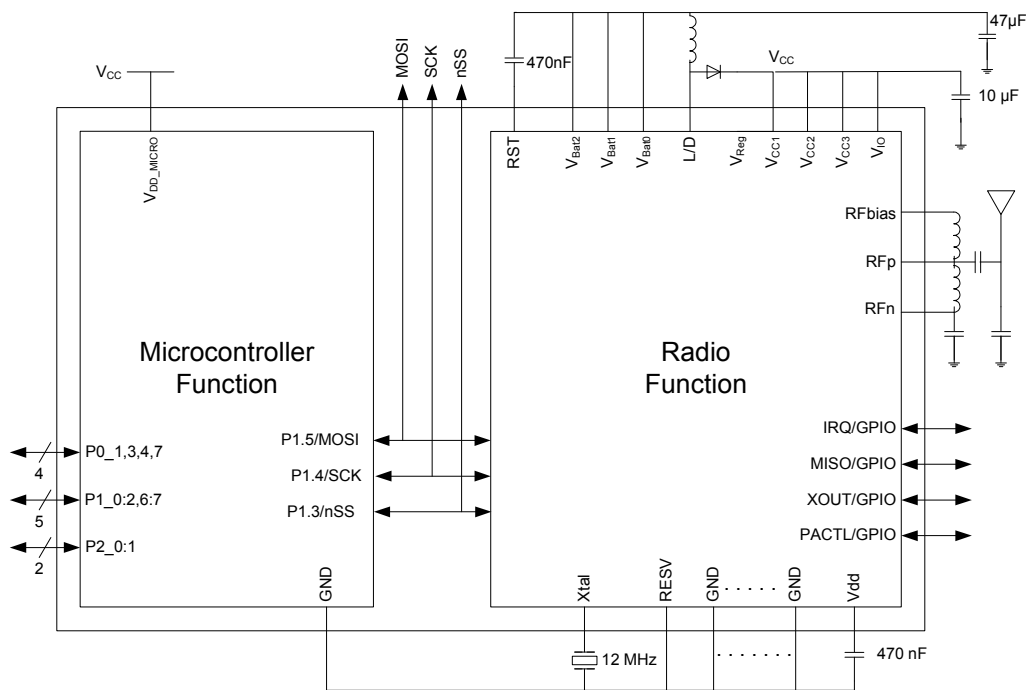

Contents

Applications	3	Flash Program Memory Organization	20
Functional Description	3	Data Memory Organization	21
Functional Overview	3	Flash	21
2.4 GHz Radio Function	3	SROM	21
Data Transmission Modes	3	SROM Function Descriptions	22
Microcontroller Function	3	Clocking	25
Backward Compatibility	4	SROM Table Read Description	26
DDR Mode	4	Clock Architecture Description	27
SDR Mode	5	CPU Clock During Sleep Mode	31
Pinouts	6	Reset	32
Pin Definitions	6	Power On Reset	33
Functional Block Overview	7	Watchdog Timer Reset	33
2.4 GHz Radio	7	Sleep Mode	33
Frequency Synthesizer	7	Sleep Sequence	33
Baseband and Framer	7	Low Power in Sleep Mode	34
Packet Buffers and Radio Configuration Registers	8	Wakeup Sequence	34
Auto Transaction Sequencer (ATS)	8	Low Voltage Detect Control	36
Interrupts	9	POR Compare State	37
Clocks	9	ECO Trim Register	37
GPIO Interface	9	General Purpose I/O Ports	38
Power On Reset/Low Voltage Detect	9	Port Data Registers	38
Timers	9	GPIO Port Configuration	39
Power Management	9	GPIO Configurations for Low Power Mode	44
Low Noise Amplifier (LNA) and		Serial Peripheral Interface (SPI)	45
Received Signal Strength Indication (RSSI)	11	SPI Data Register	46
Receive Spurious Response	11	SPI Configure Register	46
SPI Interface	11	SPI Interface Pins	48
3-Wire SPI Interface	11	Timer Registers	48
4-Wire SPI Interface	11	Registers	48
SPI Communication and Transactions	12	Interrupt Controller	51
SPI I/O Voltage References	12	Architectural Description	51
SPI Connects to External Devices	12	Interrupt Processing	52
CPU Architecture	13	Interrupt Latency	52
CPU Registers	14	Interrupt Registers	52
Flags Register	14	Microcontroller Function Register Summary	56
Accumulator Register	14	Radio Function Register Summary	58
Index Register	15	Absolute Maximum Ratings	59
Stack Pointer Register	15	DC Characteristics	59
CPU Program Counter High Register	15	AC Characteristics	61
CPU Program Counter Low Register	15	RF Characteristics	65
Addressing Modes	16	Ordering Information	67
Source Immediate	16	Ordering Code Definitions	67
Source Direct	16	Package Handling	68
Source Indexed	16	Package Diagram	68
Destination Direct	16	Acronyms	70
Destination Indexed	17	Document Conventions	70
Destination Direct Source Immediate	17	Units of Measure	70
Destination Indexed Source Immediate	17	Document History Page	71
Destination Direct Source Direct	17	Sales, Solutions, and Legal Information	72
Source Indirect Post Increment	18	Worldwide Sales and Design Support	72
Destination Indirect Post Increment	18	Products	72
Instruction Set Summary	19	PSoC Solutions	72
Memory Organization	20		

Applications

The CYRF69103 PRoC LP is targeted for the following applications:

- Wireless HID devices:
 - Mice
 - Remote Controls
 - Presenter tools
 - Barcode scanners
 - POS terminal
- General purpose wireless applications:
 - Industrial applications
 - Home automation
 - White goods
 - Consumer electronics
 - Toys

Functional Description

PRoC LP devices are integrated radio and microcontroller functions in the same package to provide a dual-role single-chip solution.

Communication between the microcontroller and the radio is through the radio's SPI interface.

Functional Overview

The CYRF69103 is a complete Radio System-on-Chip device, providing a complete RF system solution with a single device and a few discrete components. The CYRF69103 is designed to implement low cost wireless systems operating in the worldwide 2.4 GHz Industrial, Scientific, and Medical (ISM) frequency band (2.400 GHz to 2.4835 GHz).

2.4 GHz Radio Function

The SoC contains a 2.4 GHz 1 Mbps GFSK radio transceiver, packet data buffering, packet framer, DSSS baseband controller, Received Signal Strength Indication (RSSI), and SPI interface for data transfer and device configuration.

The radio supports 98 discrete 1 MHz channels (regulations may limit the use of some of these channels in certain jurisdictions). In DSSS modes the baseband performs DSSS spreading/despreading, while in GFSK Mode (1 Mb/s - GFSK) the baseband performs Start of Frame (SOF), End of Frame (EOF) detection, and CRC16 generation and checking. The baseband may also be configured to automatically transmit Acknowledge (ACK) handshake packets whenever a valid packet is received.

When in receive mode, with packet framing enabled, the device is always ready to receive data transmitted at any of the supported bit rates, except SDR, enabling the implementation of mixed-rate systems in which different devices use different data rates. This also enables the implementation of dynamic data rate systems, which use high data rates at shorter distances and/or in a low moderate interference environment, and change to lower data rates at longer distances and/or in high interference environments.

The radio meets the following worldwide regulatory requirements:

- Europe:
 - ETSI EN 301 489-1 V1.4.1
 - ETSI EN 300 328-1 V1.3.1
- North America:
 - FCC CFR 47 Part 15
- Japan:
 - ARIB STD-T66

Data Transmission Modes

The radio supports four different data transmission modes:

- In GFSK mode, data is transmitted at 1 Mbps, without any DSSS
- In 8DR mode, 1 byte is encoded in each PN code symbol transmitted
- In DDR mode, 2 bits are encoded in each PN code symbol transmitted
- In SDR mode, a single bit is encoded in each PN code symbol transmitted

Both 64-chip and 32-chip data PN codes are supported. The four data transmission modes apply to the data after the Start of Packet (SOP). In particular, the packet length, data and CRC are all sent in the same mode.

Microcontroller Function

The MCU function is an 8-bit Flash-programmable microcontroller. The instruction set is optimized specifically for HID and a variety of other embedded applications.

The MCU function has up to 8 Kbytes of Flash for user's code and up to 256 bytes of RAM for stack space and user variables.

In addition, the MCU function includes a Watchdog timer, a vectored interrupt controller, a 16-bit Free Running Timer, and 12-bit Programmable Interrupt Timer.

The microcontroller has 15 GPIO pins grouped into multiple ports. With the exception of the four radio function GPIOs, each GPIO port supports high impedance inputs, configurable pull up, open drain output, CMOS/TTL inputs and CMOS output. Up to two pins support programmable drive strength of up to 50 mA. Additionally, each I/O pin can be used to generate a GPIO interrupt to the microcontroller. Each GPIO port has its own GPIO interrupt vector with the exception of GPIO Port 0. GPIO Port 0 has two dedicated pins that have independent interrupt vectors (P0.3–P0.4).

The microcontroller features an internal oscillator.

The PRoC LP includes a Watchdog timer, a vectored interrupt controller, a 12-bit programmable interval timer with configurable 1 ms interrupt and a 16-bit free running timer.

In addition, the CYRF69103 IC has a Power Management Unit (PMU), which enables direct connection of the device to any battery voltage in the range 1.8 V to 3.6 V. The PMU conditions the battery voltage to provide the supply voltages required by the device and may supply external devices.

Backward Compatibility

The CYRF69103 IC is fully interoperable with the main modes of the first generation Cypress radios namely the CYWUSB6934-LS and CYWWUSB6935-LR devices. The 62.5 kbps mode is supported by selecting 32 chip DDR mode. Similarly, the 15.675 kbps mode is supported by selecting 64 chip SDR mode. In this method, a suitably configured CYRF69103 IC device may transmit data to or receive data from a first generation device, or both. Backwards compatibility requires disabling the SOP, length, and CRC16 fields.

This section provides the different configurations of the registers and firmware that enable a new generation radio to communicate with a first generation radio. There are two possible modes: SDR and DDR mode (8-DR and GFSK modes are not present in the first generation radio). The second generation radio must be initialized using the RadiolnitAPI of the LP radio driver and then the following registers' bits need to be configured to the given Byte values. Essentially, the following deactivates the added features of the second generation radio and takes it down to the level of the first generation radio. The data format, data rates, and the PN codes used are recognizable by the first generation radio.

DDR Mode

Table 1. DDR Mode

Register	Value	Description
TX_CFG_ADR	0X16	32 chip PN Code, DDR, PA = 6
RX_CFG_ADR	0X4B	AGC is enabled. LNA and attenuator are disabled. Fast turnaround is disabled, the device uses high side receive injection and Hi-Lo is disabled. Overwrite to receive buffer is enabled and the RX buffer is configured to receive eight bytes maximum.
XACT_CFG_ADR	0X05	AutoACK is disabled. Forcing end state is disabled. The device is configured to transition to Idle mode after a Receive or Transmit. ACK timeout is set to 128 μ s.
FRAMING_CFG_ADR	0X00	All SOP and framing features are disabled. Disable LEN_EN = 0 if EOP is needed.
TX_OVERRIDE_ADR	0X04	Disable Transmit CRC-16.
RX_OVERRIDE_ADR	0X14	The receiver rejects packets with a zero seed. The Rx CRC-16 Checker is disabled and the receiver accepts bad packets that do not match the seed in CRC_seed registers. This helps in communication with the first generation radio that does not have CRC capabilities.
ANALOG_CTRL_ADR	0X01	Set ALL SLOW. When set, the synthesizer settle time for all channels is the same as the slow channels in the first generation radio.
DATA32_THOLD_ADR	0X03	Sets the number of allowed corrupted bits to 3.
EOP_CTRL_ADR	0x01	Sets the number of consecutive symbols for non-correlation to detect end of packet.
PREAMBLE_ADR	0xAAAA05	AAAA are the two preamble bytes. Any other byte can also be written into the preamble register file. Recommended counts of the preamble bytes to be sent must be >4.

SDR Mode

Table 2. SDR Mode

Register	Value	Description
TX_CFG_ADR	0X3E	64 chip PN code, SDR mode, PA = 6
RX_CFG_ADR	0X4B	AGC is enabled. LNA and attenuator are disabled. Fast turnaround is disabled, the device uses high side receive injection and Hi-Lo is disabled. Overwrite to receive buffer is enabled and RX buffer is configured to receive eight bytes maximum. Enables RXOW to allow new packets to be loaded into the receive buffer. This also enables the VALID bit which is used by the first generation radio's error correction firmware.
XACT_CFG_ADR	0X05	AutoACK is disabled. Forcing end state is disabled. The device is configured to transition to Idle mode after Receive or Transmit. ACK timeout is set to 128 μ s.
FRAMING_CFG_ADR	0X00	All SOP and framing features are disabled. Disable LEN_EN=0 if EOP is needed.
TX_OVERRIDE_ADR	0X04	Disable Transmit CRC-16.
RX_OVERRIDE_ADR	0X14	The receiver rejects packets with a zero seed. The RX CRC-16 checker is disabled and the receiver accepts bad packets that do not match the seed in the CRC_seed registers. This helps in communication with the first generation radio that does not have CRC capabilities.
ANALOG_CTRL_ADR	0X01	Set ALL SLOW. When set, the synthesizer settle time for all channels is the same as the slow channels in the first generation radio, for manual ACK consistency
DATA64_THOLD_ADR	0X07	Sets the number of allowed corrupted bits to 7 which is close to the recommended 12% value.
EOP_CTRL_ADR	0xA1	Sets the number of consecutive symbols for non-correlation to detect end of packet.
PREAMBLE_ADR	0xAAAA09	AAAA are the two preamble bytes. Any other byte can also be written into the preamble register file. Recommended counts of the preamble bytes to be sent must be >8.

Pinouts

Figure 1. Pin Diagram

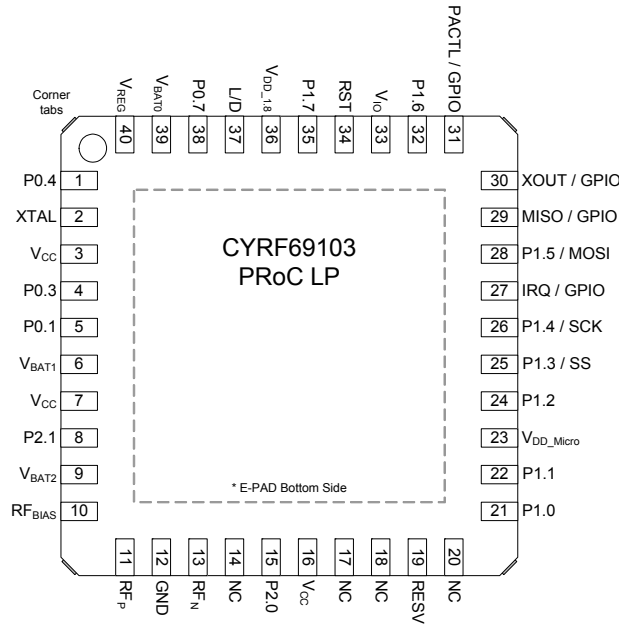

Pin Definitions

Pin	Name	Description
1	P0.4	Individually configured GPIO
2	XTAL	12 MHz crystal
3, 7, 16	V _{CC}	2.4 V to 3.6 V supply. Connected to pin 40 (0.047 μF bypass)
4	P0.3	Individually configured GPIO
5	P0.1	Individually configured GPIO
6	V _{bat1}	Connect to 1.8 V to 3.6 V power supply, through 47 ohm series/1 μF shunt C.
8	P2.1	GPIO. Port 2 Bit 1
9	V _{bat2}	Connected to 1.8 V to 3.6 V main power supply, through 0.047 μF bypass C.
10	RF _{bias}	RF pin voltage reference
11	RF _p	Differential RF to or from antenna
12	GND	GND
13	RF _n	Differential RF to or from antenna
14, 17, 18, 20	NC	
15	P2.0	GPIO
19	RESV	Reserved. Must connect to GND
21	P1.0	GPIO port 1 bit 0 / ISSP-SCLK If this pin is used as a general-purpose output it draws current. It is, therefore, configured as an input to reduce current draw.
22	P1.1	GPIO port 1 bit 1 / ISSP-SDATA If this pin is used as a general-purpose output it draws current. It is, therefore, configured as an input to reduce current draw.
23	V _{DD_micro}	MCU supply connected to pin 40, max CPU 12 MHz

Pin Definitions (continued)

Pin	Name	Description
24	P1.2	GPIO
25	P1.3 / nSS	Slave Select
26	P1.4 / SCK	SPI Clock
27	IRQ	Radio Function Interrupt output, configure High, Low or as Radio GPIO.
28	P1.5 / MOSI	MOSI pin from microcontroller function to radio function.
29	MISO	3-wire SPI mode configured as Radio GPIO. In 4-wire SPI mode sends data to MCU function.
30	XOUT	Buffered CLK, PACTL_n or Radio GPIO.
31	PACTL	Control for external PA or Radio GPIO.
32	P1.6	GPIO
33	V _{IO}	1.8 V to 3.6V to main power supply rail for Radio I/O.
34	RST	Radio Reset. Connected to pin 40 with 0.47 μF. Must have a RST = HIGH event the very first time power is applied to the radio otherwise the state of the radio control registers is unknown.
35	P1.7	GPIO
36	V _{DD1.8}	Regulated logic bypass. Connected to 0.47 μF to GND.
37	L/D	Inductor/Diode connection for Boost. When Internal PMU is not being used connect L/D to GND.
38	P0.7	GPIO
39	V _{bat0}	Connected to 1.8 V to 3.6 V main power supply, through 0.047 μF bypass C.
40	V _{REG}	Boost regulator output voltage feedback
41	E-pad	Must be connected to ground.
42	Corner Tabs	Do Not connect corner tabs.

Functional Block Overview

All the blocks that make up the PRoC LP are presented in this section.

2.4 GHz Radio

The radio transceiver is a dual conversion low IF architecture optimized for power and range/robustness. The radio employs channel matched filters to achieve high performance in the presence of interference. An integrated Power Amplifier (PA) provides up to +4 dBm transmit power, with an output power control range of 34 dB in eight steps. The supply current of the device is reduced as the RF output power is reduced.

Table 3. Internal PA Output Power Step Table

PA Setting	Typical Output Power (dBm)
7	+4
6	0
5	-5
4	-10
3	-15
2	-20
1	-25
0	-30

Frequency Synthesizer

Before transmission or reception may commence, it is necessary for the frequency synthesizer to settle. The settling time varies depending on channel; 25 fast channels are provided with a maximum settling time of 100 μs.

The “fast channels” (<100 μs settling time) are every 3rd frequency, starting at 2400 MHz up to and including 2472 MHz (that is, 0,3,6,9.....69 and 72).

Baseband and Framer

The baseband and framer blocks provide the DSSS encoding and decoding, SOP generation and reception and CRC16 generation and checking, and EOP detection and length field.

Data Transmission Modes and Data Rates

The SoC supports four different data transmission modes:

- In GFSK mode, data is transmitted at 1 Mbps, without any DSSS.
- In 8DR mode, 8 bits are encoded in each DATA_CODE_ADR derived code symbol transmitted.
- In DDR mode, 2 bits are encoded in each DATA_CODE_ADR derived code symbol transmitted (as in the CYWUSB6934 DDR mode).
- In SDR mode, 1 bit is encoded in each DATA_CODE_ADR derived code symbol transmitted (as in the CYWUSB6934 standard modes).

Both 64-chip and 32-chip DATA_CODE_ADR codes are supported. The four data transmission modes apply to the data after the SOP. In particular the length, data, and CRC16 are all sent in the same mode. In general, lower data rates reduces packet error rate in any given environment.

The CYRF69103 IC supports the following data rates:

- 1000 kbps (GFSK)
- 250 kbps (32-chip 8DR)
- 125 kbps (64-chip 8DR)
- 62.5 kbps (32-chip DDR)
- 31.25 kbps (64-chip DDR)
- 15.625 kbps (64-chip SDR)

Lower data rates typically provide longer range and/or a more robust link.

Link Layer Modes

The CYRF69103 IC device supports the following data packet framing features:

SOP – Packets begin with a 2-symbol Start of Packet (SOP) marker. This is required in GFSK and 8DR modes, but is optional in DDR mode and is not supported in SDR mode. If framing is disabled then an SOP event is inferred whenever two successive correlations are detected. The SOP_CODE_ADR code used for the SOP is different from that used for the “body” of the packet, and if desired may be a different length. SOP must be configured to be the same length on both sides of the link.

EOP – There are two options for detecting the end of a packet. If SOP is enabled, then a packet length field may be enabled. GFSK and 8DR must enable the length field. This is the first 8 bits after the SOP symbol, and is transmitted at the payload data rate. If the length field is enabled, an End of Packet (EOP) condition is inferred after reception of the number of bytes defined in the length field, plus two bytes for the CRC16 (if enabled). The alternative to using the length field is to infer an EOP condition from a configurable number of successive non correlations; this option is not available in GFSK mode and is only recommended when using SDR mode.

CRC16 – The device may be configured to append a 16-bit CRC16 to each packet. The CRC16 uses the USB CRC polynomial with the added programmability of the seed. If enabled, the receiver verifies the calculated CRC16 for the payload data against the received value in the CRC16 field. The starting value for the CRC16 calculation is configurable, and the CRC16 transmitted may be calculated using either the loaded seed value or a zero seed; the received data CRC16 is checked against both the configured and zero CRC16 seeds.

CRC16 detects the following errors:

- Any one bit in error
- Any two bits in error (no matter how far apart, which column, and so on)
- Any odd number of bits in error (no matter where they are)
- An error burst as wide as the checksum itself

Figure 2 shows an example packet with SOP, CRC16 and lengths fields enabled.

Figure 2. Example Default Packet Format

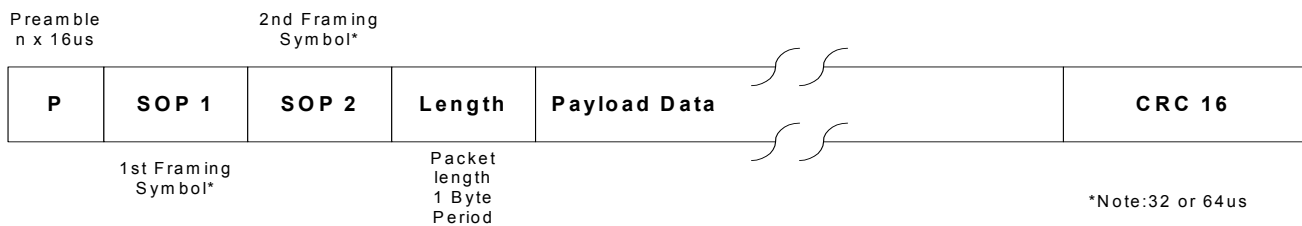

Packet Buffers and Radio Configuration Registers

Packet data and configuration registers are accessed through the SPI interface. All configuration registers are directly addressed through the address field in the SPI packet (as in the CYWUSB6934). Configuration registers are provided to allow configuration of DSSS PN codes, data rate, operating mode, interrupt masks, interrupt status, and others.

Packet Buffers

All data transmission and reception use the 16-byte packet buffers: one for transmission and one for reception.

The transmit buffer allows a complete packet of up to 16 bytes of payload data to be loaded in one burst SPI transaction, and then transmitted with no further MCU intervention. Similarly, the receive buffer allows an entire packet of payload data up to 16 bytes to be received with no firmware intervention required until packet reception is complete.

The CYRF69103 IC supports packet length of up to 40 bytes; interrupts are provided to allow an MCU to use the transmit and receive buffers as FIFOs. When transmitting a packet longer than 16 bytes, the MCU can load 16 bytes initially, and add further bytes to the transmit buffer as transmission of data creates space in the buffer. Similarly, when receiving packets longer than 16 bytes, the MCU must fetch received data from the FIFO periodically during packet reception to prevent it from overflowing.

Auto Transaction Sequencer (ATS)

The CYRF69103 IC provides automated support for transmission and reception of acknowledged data packets.

When transmitting a data packet, the device automatically starts the crystal and synthesizer, enters transmit mode, transmits the packet in the transmit buffer, and then automatically switches to receive mode and waits for a handshake packet – and then

automatically reverts to sleep mode or idle mode when either an ACK packet is received, or a time out period expires.

Similarly, when receiving in transaction mode, the device waits in receive mode for a valid packet to be received, then automatically transitions to transmit mode, transmits an ACK packet, and then switches back to receive mode to await the next packet. The contents of the packet buffers are not affected by the transmission or reception of ACK packets.

In each case, the entire packet transaction takes place without any need for MCU firmware action; to transmit data the MCU simply needs to load the data packet to be transmitted, set the length, and set the TX GO bit. Similarly, when receiving packets in transaction mode, firmware simply needs to retrieve the fully received packet in response to an interrupt request indicating reception of a packet.

Interrupts

The radio function provides an interrupt (IRQ) output, which is configurable to indicate the occurrence of various different events. The IRQ pin may be programmed to be either active high or active low, and be either a CMOS or open drain output.

The radio function features three sets of interrupts: transmit, receive, and system interrupts. These interrupts all share a single pin (IRQ), but can be independently enabled/disabled. In transmit mode, all receive interrupts are automatically disabled, and in receive mode all transmit interrupts are automatically disabled. However, the contents of the enable registers are preserved when switching between transmit and receive modes.

If more than one radio interrupt is enabled at any time, it is necessary to read the relevant status register to determine which event caused the IRQ pin to assert. Even when a given interrupt source is disabled, the status of the condition that would otherwise cause an interrupt can be determined by reading the appropriate status register. It is therefore possible to use the devices without making use of the IRQ pin by polling the status register(s) to wait for an event, rather than using the IRQ pin.

Clocks

A 12 MHz crystal (30 ppm or better) is directly connected between XTAL and GND without the need for external capacitors. A digital clock out function is provided, with selectable output frequencies of 0.75, 1.5, 3, 6, or 12 MHz. This output may be used to clock an external microcontroller (MCU) or ASIC. This output is enabled by default, but may be disabled.

The requirements for the crystal to be directly connected to XTAL pin and GND are:

- Nominal Frequency: 12 MHz
- Operating Mode: Fundamental Mode
- Resonance Mode: Parallel Resonant
- Frequency Initial Stability: ± 30 ppm
- Series Resistance: ≤ 60 ohms
- Load Capacitance: 10 pF
- Drive Level: 100 μ W

The MCU function features an internal oscillator. The clock generator provides the 12 MHz and 24 MHz clocks that remain internal to the microcontroller.

GPIO Interface

The MCU function features up to 15 general purpose I/O (GPIO) pins. The I/O pins are grouped into three ports (Port 0 to 2). The pins on Port 0 and Port 1 may each be configured individually while the pins on Port 2 may only be configured as a group. Each GPIO port supports high-impedance inputs, configurable pull up, open drain output, CMOS/TTL inputs, and CMOS output with up to two pins that support programmable drive strength of up to 50 mA sink current. Additionally, each I/O pin can be used to generate a GPIO interrupt to the microcontroller. Each GPIO port has its own GPIO interrupt vector with the exception of GPIO Port 0. GPIO Port 0 has three dedicated pins that have independent interrupt vectors (P0.1, P0.3–P0.4).

Power On Reset/Low Voltage Detect

The power on reset circuit detects logic when power is applied to the device, resets the logic to a known state, and begins executing instructions at Flash address 0x0000. When power falls below a programmable trip voltage, it generates reset or may be configured to generate interrupt. There is a low voltage detect circuit that detects when V_{CC} drops below a programmable trip voltage. It may be configurable to generate an LVD interrupt to inform the processor about the low voltage event. POR and LVD share the same interrupt. There is not a separate interrupt for each. The Watchdog timer can be used to ensure the firmware never gets stalled in an infinite loop.

Timers

The free running 16-bit timer provides two interrupt sources: the programmable interval timer with 1- μ s resolution and the 1.024 ms outputs. The timer can be used to measure the duration of an event under firmware control by reading the timer at the start and at the end of an event, then calculating the difference between the two values.

Power Management

The operating voltage of the device is 1.8V to 3.6V DC, which is applied to the V_{BAT} pin. The device can be shut down to a fully static sleep mode by writing to the FRC END = 1 and END STATE = 000 bits in the XACT_CFG_ADR register over the SPI interface. The device enters sleep mode within 35 μ s after the last SCK positive edge at the end of this SPI transaction. Alternatively, the device may be configured to automatically enter sleep mode after completing packet transmission or reception. When in sleep mode, the on-chip oscillator is stopped, but the SPI interface remains functional. The device wakes from sleep mode automatically when the device is commanded to enter transmit or receive mode. When resuming from sleep mode, there is a short delay while the oscillator restarts. The device may be configured to assert the IRQ pin when the oscillator has stabilized.

The output voltage (V_{REG}) of the Power Management Unit (PMU) is configurable to several minimum values between 2.4 V and 2.7 V. V_{REG} may be used to provide up to 15 mA (average load) to external devices. It is possible to disable the PMU, and to provide an externally regulated DC supply voltage to the

device in the range 2.4 V to 3.6 V. The PMU also provides a regulated 1.8 V supply to the logic.

The PMU has been designed to provide high boost efficiency (74–85% depending on input voltage, output voltage and load) when using a Schottky diode and power inductor, eliminating the need for an external boost converter in many systems where other components require a boosted voltage. However, reasonable efficiencies (69–82% depending on input voltage, output voltage and load) may be achieved when using low-cost components such as SOT23 diodes and 0805 inductors.

The current through the diode must stay within the linear operating range of the diode. For some loads the SOT23 diode is sufficient, but with higher loads it is not and a SS12 diode must be used to stay within this linear range of operation. Along with the diode, the inductor used must not saturate its core. In higher loads, a lower resistance/higher saturation coil like the inductor from Sumida must be used.

The PMU also provides a configurable low battery detection function which may be read over the SPI interface. One of seven thresholds between 1.8 V and 2.7 V may be selected. The interrupt pin may be configured to assert when the voltage on the V_{BAT} pin falls below the configured threshold. LV IRQ is not a latched event. Battery monitoring is disabled when the device is in sleep mode.

The following three figures show different examples of how to use PRoC LP with and without the PMU. **Figure 3** shows the most common circuit making use of the PMU to boost battery voltage up to 2.7 V. **Figure 4** is an example of the circuit used when the supply voltage is always above 2.7 V. This could be three 1.5 V battery cells in series along with a linear regulator, or some similar power source. **Figure 5** shows an example of using the PRoC LP with its PMU disabled and an external boost to supply power to the device. This might be required when the load is much greater than the 15 mA average load that PRoC can support.

Figure 3. PMU Enabled

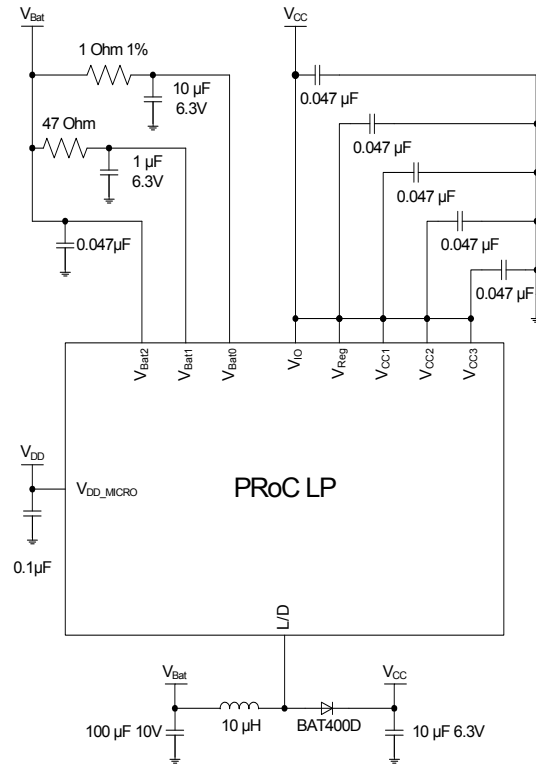

Figure 4. PMU Disabled - Linear Regulator

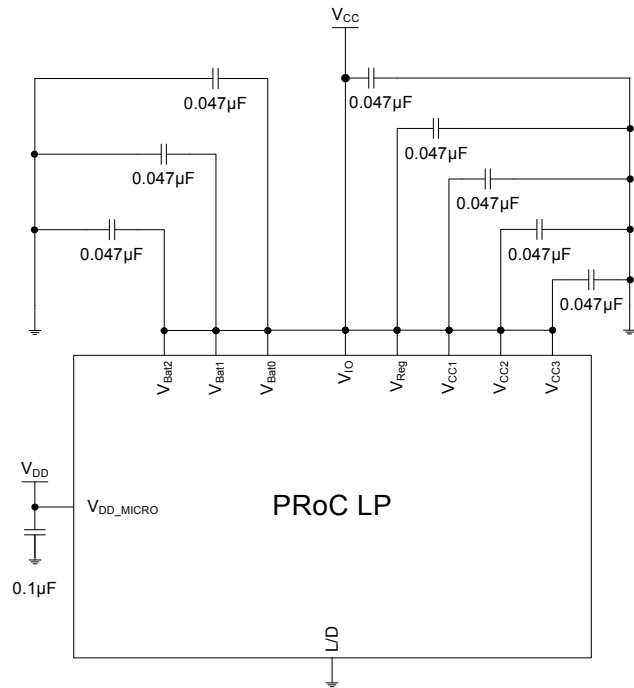
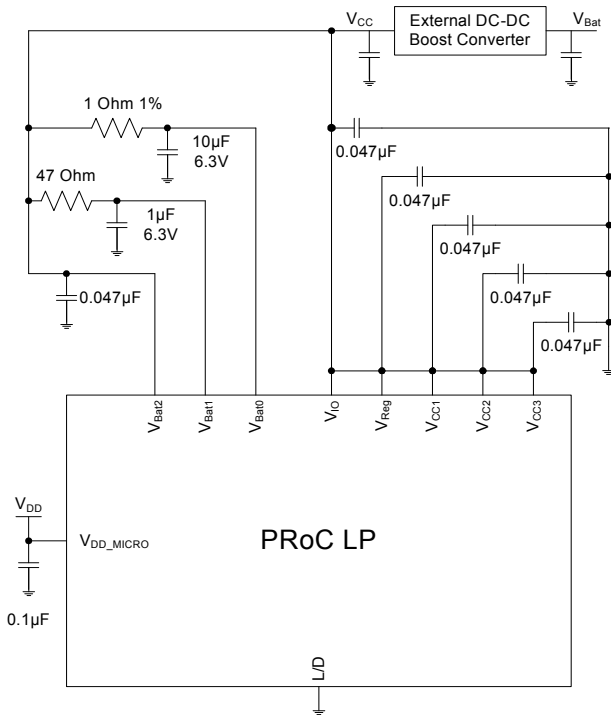

Figure 5. PMU Disabled - External Boost Converter



Low Noise Amplifier (LNA) and Received Signal Strength Indication (RSSI)

The gain of the receiver may be controlled directly by clearing the AGC EN bit and writing to the Low Noise Amplifier (LNA) bit of the RX_CFG_ADR register. When the LNA bit is cleared, the receiver gain is reduced by approximately 20 dB, allowing accurate reception of very strong received signals (for example when operating a receiver very close to the transmitter). An additional 20 dB of receiver attenuation can be added by setting the Attenuation (ATT) bit; this allows data reception to be limited to devices at very short ranges. Disabling AGC and enabling LNA is recommended unless receiving from a device using external PA.

The RSSI register returns the relative signal strength of the on-channel signal power.

When receiving, the device may be configured to automatically measure and store the relative strength of the signal being received as a 5-bit value. When enabled, an RSSI reading is taken and may be read through the SPI interface. An RSSI reading is taken automatically when the start of a packet is detected. In addition, a new RSSI reading is taken every time the previous reading is read from the RSSI register, allowing the background RF energy level on any given channel to be easily measured when RSSI is read when no signal is being received. A new reading can occur as fast as once every 12 μs.

Receive Spurious Response

The transmitter may exhibit spurs around 50MHz offset at levels approximately 50dB to 60dB below the carrier power. Receivers

operating at the transmit spur frequency may receive the spur if the spur level power is greater than the receive sensitivity level.

The workaround for this is to program an additional byte in the packet header which contains the transmitter channel number. After the packet is received, the channel number can be checked. If the channel number does not match the receive channel then the packet is rejected.

SPI Interface

The SPI interface between the MCU function and the radio function is a 3-wire SPI Interface. The three pins are MOSI (Master Out Slave In), SCK (Serial Clock), SS (Slave Select). There is an alternate 4-wire MISO Interface that requires the connection of two external pins. The SPI interface is controlled by configuring the SPI Configure Register. (SPICR Addr: 0x3D).

3-Wire SPI Interface

The radio function receives a clock from the MCU function on the SCK pin. The MOSI pin is multiplexed with the MISO pin. Bidirectional data transfer takes place between the MCU function and the radio function through this multiplexed MOSI pin. When using this mode the user firmware must ensure that the MOSI pin on the MCU function is in a high impedance state, except when the MCU is actively transmitting data. Firmware must also control the direction of data flow and switch directions between MCU function and radio function by setting the SWAP bit [Bit 7] of the SPI Configure Register. The SS pin is asserted before initiating a data transfer between the MCU function and the radio function. The IRQ function may be optionally multiplexed with the MOSI pin; when this option is enabled the IRQ function is not available while the SS pin is low. When using this configuration, user firmware must ensure that the MOSI function on MCU function is in a high-impedance state whenever SS is high.

Figure 6. 3-Wire SPI Mode

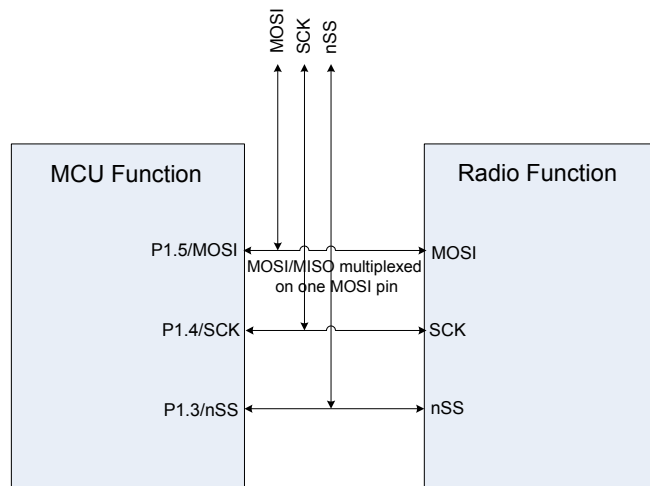

4-Wire SPI Interface

The 4-wire SPI communications interface consists of MOSI, MISO, SCK, and SS.

The device receives SCK from the MCU function on the SCK pin. Data from the MCU function is shifted in on the MOSI pin. Data to the MCU function is shifted out on the MISO pin. The active low SS pin must be asserted for the two functions to communicate. The IRQ function may be optionally multiplexed with the MOSI pin; when this option is enabled the IRQ function is not available while the SS pin is low. When using this configuration, user firmware must ensure that the MOSI function on MCU function is in a high-impedance state whenever SS is high.

Figure 7. 4-Wire SPI Mode

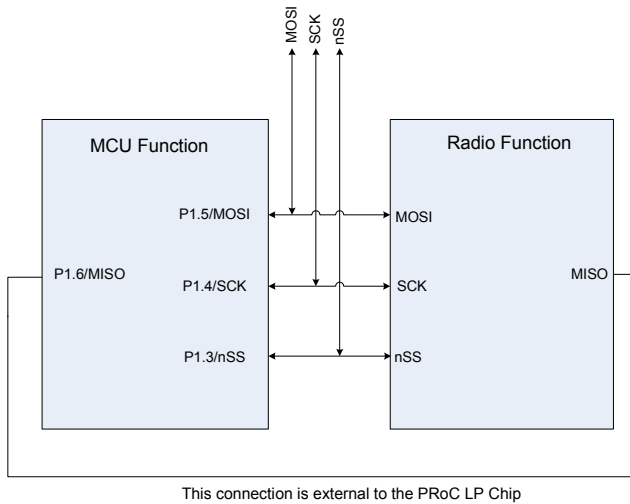

SPI Communication and Transactions

The SPI transactions can be single byte or multi-byte. The MCU function initiates a data transfer through a Command/Address

Table 4. SPI Transaction Format

	Byte 1			Byte 1+N
Bit #	7	6	[5:0]	[7:0]
Bit Name	DIR	INC	Address	Data

byte. The following bytes are data bytes. The SPI transaction format is shown in Figure 4.

The DIR bit specifies the direction of data transfer. 0 = Master reads from slave. 1 = Master writes to slave.

The INC bit helps to read or write consecutive bytes from contiguous memory locations in a single burst mode operation.

If Slave Select is asserted and INC = 1, then the master MCU function reads a byte from the radio, the address is incremented by a byte location, and then the byte at that location is read, and so on.

If Slave Select is asserted and INC = 0, then the MCU function reads/writes the bytes in the same register in burst mode, but if it is a register file then it reads/writes the bytes in that register file.

The SPI interface between the radio function and the MCU is not dependent on the internal 12 MHz oscillator of the radio. Therefore, radio function registers can be read from or written into while the radio is in sleep mode.

SPI I/O Voltage References

The SPI interfaces between MCU function and the radio and the IRQ and RST have a separate voltage reference V_{IO} . For CYRF69103 V_{IO} is normally set to V_{CC} .

SPI Connects to External Devices

The three SPI wires, MOSI, SCK, and SS are also drawn out of the package as external pins to allow the user to interface their own external devices (such as optical sensors and others) through SPI. The radio function also has its own SPI wires MISO and IRQ, which can be used to send data back to the MCU function or send an interrupt request to the MCU function. They can also be configured as GPIO pins.

CPU Architecture

This family of microcontrollers is based on a high-performance, 8-bit, Harvard architecture microprocessor. Five registers control the primary operation of the CPU core. These registers are affected by various instructions, but are not directly accessible through the register space by the user.

Table 5. CPU Registers and Register Name

Register	Register Name
Flags	CPU_F
Program Counter	CPU_PC
Accumulator	CPU_A
Stack Pointer	CPU_SP
Index	CPU_X

The 16-bit Program Counter Register (CPU_PC) allows for direct addressing of the full eight Kbytes of program memory space.

The Accumulator Register (CPU_A) is the general-purpose register that holds the results of instructions that specify any of the source addressing modes.

The Index Register (CPU_X) holds an offset value that is used in the indexed addressing modes. Typically, this is used to address a block of data within the data memory space.

The Stack Pointer Register (CPU_SP) holds the address of the current top-of-stack in the data memory space. It is affected by the PUSH, POP, LCALL, CALL, RETI, and RET instructions, which manage the software stack. It can also be affected by the SWAP and ADD instructions.

The Flag Register (CPU_F) has three status bits: Zero Flag bit [1]; Carry Flag bit [2]; Supervisory State bit [3]. The Global Interrupt Enable bit [0] is used to globally enable or disable interrupts. The user cannot manipulate the Supervisory State status bit [3]. The flags are affected by arithmetic, logic, and shift operations. The manner in which each flag is changed is dependent upon the instruction being executed (for example, AND, OR, XOR). See [Table 22](#) on page 19.

CPU Registers

Flags Register

The Flags Register can only be set or reset with logical instruction.

Table 6. CPU Flags Register (CPU_F) [R/W]

Bit #	7	6	5	4	3	2	1	0
Field	Reserved			XIO	Super	Carry	Zero	Global IE
Read/Write	–	–	–	R/W	R	RW	RW	RW
Default	0	0	0	0	0	0	1	0

Bits 7:5 Reserved

Bit 4 XIO
Set by the user to select between the register banks.
0 = Bank 0
1 = Bank 1

Bit 3 Super
Indicates whether the CPU is executing user code or Supervisor Code (This code cannot be accessed directly by the user).
0 = User Code
1 = Supervisor Code

Bit 2 Carry
Set by CPU to indicate whether there has been a carry in the previous logical/arithmetic operation.
0 = No Carry
1 = Carry

Bit 1 Zero
Set by CPU to indicate whether there has been a zero result in the previous logical/arithmetic operation.
0 = Not Equal to Zero
1 = Equal to Zero

Bit 0 Global IE
Determines whether all interrupts are enabled or disabled.
0 = Disabled
1 = Enabled

Note This register is readable with explicit address 0xF7. The *OR F, expr* and *AND F, expr* must be used to set and clear the CPU_F bits.

Accumulator Register

Table 7. CPU Accumulator Register (CPU_A)

Bit #	7	6	5	4	3	2	1	0
Field	CPU Accumulator [7:0]							
Read/Write	–	–	–	–	–	–	–	–
Default	0	0	0	0	0	0	0	0

Bits 7:0 CPU Accumulator [7:0]

8-bit data value holds the result of any logical/arithmetic instruction that uses a source addressing mode.

Index Register

Table 8. CPU X Register (CPU_X)

Bit #	7	6	5	4	3	2	1	0
Field	X [7:0]							
Read/Write	–	–	–	–	–	–	–	–
Default	0	0	0	0	0	0	0	0

Bits 7:0 X [7:0]
8-bit data value holds an index for any instruction that uses an indexed addressing mode.

Stack Pointer Register

Table 9. CPU Stack Pointer Register (CPU_SP)

Bit #	7	6	5	4	3	2	1	0
Field	Stack Pointer [7:0]							
Read/Write	–	–	–	–	–	–	–	–
Default	0	0	0	0	0	0	0	0

Bits 7:0 Stack Pointer [7:0]
8-bit data value holds a pointer to the current top-of-stack.

CPU Program Counter High Register

Table 10. CPU Program Counter High Register (CPU_PCH)

Bit #	7	6	5	4	3	2	1	0
Field	Program Counter [15:8]							
Read/Write	–	–	–	–	–	–	–	–
Default	0	0	0	0	0	0	0	0

Bits 7:0 Program Counter [15:8]
8-bit data value holds the higher byte of the program counter.

CPU Program Counter Low Register

Table 11. CPU Program Counter Low Register (CPU_PCL)

Bit #	7	6	5	4	3	2	1	0
Field	Program Counter [7:0]							
Read/Write	–	–	–	–	–	–	–	–
Default	0	0	0	0	0	0	0	0

Bit 7:0 Program Counter [7:0]
8-bit data value holds the lower byte of the program counter.

Addressing Modes

Examples of the different addressing modes are discussed in this section and example code is given.

Source Immediate

The result of an instruction using this addressing mode is placed in the A register, the F register, the SP register, or the X register, which is specified as part of the instruction opcode. Operand 1 is an immediate value that serves as a source for the instruction. Arithmetic instructions require two sources. Instructions using this addressing mode are two bytes in length.

Table 12. Source Immediate

Opcode	Operand 1
Instruction	Immediate Value

Examples

- ADD A, 7 In this case, the immediate value of 7 is added with the Accumulator, and the result is placed in the Accumulator.
- MOV X, 8 In this case, the immediate value of 8 is moved to the X register.
- AND F, 9 In this case, the immediate value of 9 is logically ANDed with the F register and the result is placed in the F register.

Source Direct

The result of an instruction using this addressing mode is placed in either the A register or the X register, which is specified as part of the instruction opcode. Operand 1 is an address that points to a location in either the RAM memory space or the register space that is the source for the instruction. Arithmetic instructions require two sources; the second source is the A register or X register specified in the opcode. Instructions using this addressing mode are two bytes in length.

Table 13. Source Direct

Opcode	Operand 1
Instruction	Source Address

Examples

- ADD A, [7] In this case, the value in the RAM memory location at address 7 is added with the Accumulator, and the result is placed in the Accumulator.
- MOV X, REG[8] In this case, the value in the register space at address 8 is moved to the X register.

Source Indexed

The result of an instruction using this addressing mode is placed in either the A register or the X register, which is specified as part of the instruction opcode. Operand 1 is added to the X register forming an address that points to a location in either the RAM memory space or the register space that is the source for the instruction. Arithmetic instructions require two sources; the second source is the A register or X register specified in the opcode. Instructions using this addressing mode are two bytes in length.

Table 14. Source Indexed

Opcode	Operand 1
Instruction	Source Index

Examples

- ADD A, [X+7] In this case, the value in the memory location at address X + 7 is added with the Accumulator, and the result is placed in the Accumulator.
- MOV X, REG[X+8] In this case, the value in the register space at address X + 8 is moved to the X register.

Destination Direct

The result of an instruction using this addressing mode is placed within either the RAM memory space or the register space. Operand 1 is an address that points to the location of the result. The source for the instruction is either the A register or the X register, which is specified as part of the instruction opcode. Arithmetic instructions require two sources; the second source is the location specified by Operand 1. Instructions using this addressing mode are two bytes in length.

Table 15. Destination Direct

Opcode	Operand 1
Instruction	Destination Address

Examples

- ADD [7], A In this case, the value in the memory location at address 7 is added with the Accumulator, and the result is placed in the memory location at address 7. The Accumulator is unchanged.
- MOV REG[8], A In this case, the Accumulator is moved to the register space location at address 8. The Accumulator is unchanged.

Destination Indexed

The result of an instruction using this addressing mode is placed within either the RAM memory space or the register space. Operand 1 is added to the X register forming the address that points to the location of the result. The source for the instruction is the A register. Arithmetic instructions require two sources; the second source is the location specified by Operand 1 added with the X register. Instructions using this addressing mode are two bytes in length.

Table 16. Destination Indexed

Opcode	Operand 1
Instruction	Destination Index

Example

ADD [X+7], A In this case, the value in the memory location at address X+7 is added with the Accumulator, and the result is placed in the memory location at address x+7. The Accumulator is unchanged.

Destination Direct Source Immediate

The result of an instruction using this addressing mode is placed within either the RAM memory space or the register space. Operand 1 is the address of the result. The source for the instruction is Operand 2, which is an immediate value. Arithmetic instructions require two sources; the second source is the location specified by Operand 1. Instructions using this addressing mode are three bytes in length.

Table 17. Destination Direct Source Immediate

Opcode	Operand 1	Operand 2
Instruction	Destination Address	Immediate Value

Examples

ADD [7], 5 In this case, value in the memory location at address 7 is added to the immediate value of 5, and the result is placed in the memory location at address 7.

MOV REG[8], 6 In this case, the immediate value of 6 is moved into the register space location at address 8.

Destination Indexed Source Immediate

The result of an instruction using this addressing mode is placed within either the RAM memory space or the register space. Operand 1 is added to the X register to form the address of the result. The source for the instruction is Operand 2, which is an immediate value. Arithmetic instructions require two sources; the second source is the location specified by Operand 1 added with the X register. Instructions using this addressing mode are three bytes in length.

Table 18. Destination Indexed Source Immediate

Opcode	Operand 1	Operand 2
Instruction	Destination Index	Immediate Value

Examples

ADD [X+7], 5 In this case, the value in the memory location at address X+7 is added with the immediate value of 5 and the result is placed in the memory location at address X+7.

MOV REG[X+8], 6 In this case, the immediate value of 6 is moved into the location in the register space at address X+8.

Destination Direct Source Direct

The result of an instruction using this addressing mode is placed within the RAM memory. Operand 1 is the address of the result. Operand 2 is an address that points to a location in the RAM memory that is the source for the instruction. This addressing mode is only valid on the MOV instruction. The instruction using this addressing mode is three bytes in length.

Table 19. Destination Direct Source Direct

Opcode	Operand 1	Operand 2
Instruction	Destination Address	Source Address

Example

MOV [7], [8] In this case, the value in the memory location at address 8 is moved to the memory location at address 7.

Source Indirect Post Increment

The result of an instruction using this addressing mode is placed in the Accumulator. Operand 1 is an address pointing to a location within the memory space, which contains an address (the indirect address) for the source of the instruction. The indirect address is incremented as part of the instruction execution. This addressing mode is only valid on the MVI instruction. The instruction using this addressing mode is two bytes in length. Refer to the *PSoC Designer: Assembly Language User Guide* for further details on MVI instruction.

Table 20. Source Indirect Post Increment

Opcode	Operand 1
Instruction	Source Address Address

Example

MVI A, [8] In this case, the value in the memory location at address 8 is an indirect address. The memory location pointed to by the indirect address is moved into the Accumulator. The indirect address is then incremented.

Destination Indirect Post Increment

The result of an instruction using this addressing mode is placed within the memory space. Operand 1 is an address pointing to a location within the memory space, which contains an address (the indirect address) for the destination of the instruction. The indirect address is incremented as part of the instruction execution. The source for the instruction is the Accumulator. This addressing mode is only valid on the MVI instruction. The instruction using this addressing mode is two bytes in length.

Table 21. Destination Indirect Post Increment

Opcode	Operand 1
Instruction	Destination Address Address

Example

MVI [8], A In this case, the value in the memory location at address 8 is an indirect address. The Accumulator is moved into the memory location pointed to by the indirect address. The indirect address is then incremented.

Instruction Set Summary

The instruction set is summarized in [Table 22](#) numerically and serves as a quick reference. If more information is needed, the Instruction Set Summary tables are described in detail in the *PSoC Designer Assembly Language User Guide* (available on www.cypress.com).

Table 22. Instruction Set Summary Sorted Numerically by Opcode Order [1, 2]

Opcode Hex	Cycles	Bytes	Instruction Format	Flags	Opcode Hex	Cycles	Bytes	Instruction Format	Flags	Opcode Hex	Cycles	Bytes	Instruction Format	Flags
00	15	1	SSC		2D	8	2	OR [X+expr], A	Z	5A	5	2	MOV [expr], X	
01	4	2	ADD A, expr	C, Z	2E	9	3	OR [expr], expr	Z	5B	4	1	MOV A, X	Z
02	6	2	ADD A, [expr]	C, Z	2F	10	3	OR [X+expr], expr	Z	5C	4	1	MOV X, A	
03	7	2	ADD A, [X+expr]	C, Z	30	9	1	HALT		5D	6	2	MOV A, reg[expr]	Z
04	7	2	ADD [expr], A	C, Z	31	4	2	XOR A, expr	Z	5E	7	2	MOV A, reg[X+expr]	Z
05	8	2	ADD [X+expr], A	C, Z	32	6	2	XOR A, [expr]	Z	5F	10	3	MOV [expr], [expr]	
06	9	3	ADD [expr], expr	C, Z	33	7	2	XOR A, [X+expr]	Z	60	5	2	MOV reg[expr], A	
07	10	3	ADD [X+expr], expr	C, Z	34	7	2	XOR [expr], A	Z	61	6	2	MOV reg[X+expr], A	
08	4	1	PUSH A		35	8	2	XOR [X+expr], A	Z	62	8	3	MOV reg[expr], expr	
09	4	2	ADC A, expr	C, Z	36	9	3	XOR [expr], expr	Z	63	9	3	MOV reg[X+expr], expr	
0A	6	2	ADC A, [expr]	C, Z	37	10	3	XOR [X+expr], expr	Z	64	4	1	ASL A	C, Z
0B	7	2	ADC A, [X+expr]	C, Z	38	5	2	ADD SP, expr		65	7	2	ASL [expr]	C, Z
0C	7	2	ADC [expr], A	C, Z	39	5	2	CMP A, expr	if (A=B) Z=1 if (A<B) C=1	66	8	2	ASL [X+expr]	C, Z
0D	8	2	ADC [X+expr], A	C, Z	3A	7	2	CMP A, [expr]		67	4	1	ASR A	C, Z
0E	9	3	ADC [expr], expr	C, Z	3B	8	2	CMP A, [X+expr]		68	7	2	ASR [expr]	C, Z
0F	10	3	ADC [X+expr], expr	C, Z	3C	8	3	CMP [expr], expr		69	8	2	ASR [X+expr]	C, Z
10	4	1	PUSH X		3D	9	3	CMP [X+expr], expr		6A	4	1	RLC A	C, Z
11	4	2	SUB A, expr	C, Z	3E	10	2	MVI A, [[expr]++]	Z	6B	7	2	RLC [expr]	C, Z
12	6	2	SUB A, [expr]	C, Z	3F	10	2	MVI [[expr]++], A		6C	8	2	RLC [X+expr]	C, Z
13	7	2	SUB A, [X+expr]	C, Z	40	4	1	NOP		6D	4	1	RRC A	C, Z
14	7	2	SUB [expr], A	C, Z	41	9	3	AND reg[expr], expr	Z	6E	7	2	RRC [expr]	C, Z
15	8	2	SUB [X+expr], A	C, Z	42	10	3	AND reg[X+expr], expr	Z	6F	8	2	RRC [X+expr]	C, Z
16	9	3	SUB [expr], expr	C, Z	43	9	3	OR reg[expr], expr	Z	70	4	2	AND F, expr	C, Z
17	10	3	SUB [X+expr], expr	C, Z	44	10	3	OR reg[X+expr], expr	Z	71	4	2	OR F, expr	C, Z
18	5	1	POP A	Z	45	9	3	XOR reg[expr], expr	Z	72	4	2	XOR F, expr	C, Z
19	4	2	SBB A, expr	C, Z	46	10	3	XOR reg[X+expr], expr	Z	73	4	1	CPL A	Z
1A	6	2	SBB A, [expr]	C, Z	47	8	3	TST [expr], expr	Z	74	4	1	INC A	C, Z
1B	7	2	SBB A, [X+expr]	C, Z	48	9	3	TST [X+expr], expr	Z	75	4	1	INC X	C, Z
1C	7	2	SBB [expr], A	C, Z	49	9	3	TST reg[expr], expr	Z	76	7	2	INC [expr]	C, Z
1D	8	2	SBB [X+expr], A	C, Z	4A	10	3	TST reg[X+expr], expr	Z	77	8	2	INC [X+expr]	C, Z
1E	9	3	SBB [expr], expr	C, Z	4B	5	1	SWAP A, X	Z	78	4	1	DEC A	C, Z
1F	10	3	SBB [X+expr], expr	C, Z	4C	7	2	SWAP A, [expr]	Z	79	4	1	DEC X	C, Z
20	5	1	POP X		4D	7	2	SWAP X, [expr]		7A	7	2	DEC [expr]	C, Z
21	4	2	AND A, expr	Z	4E	5	1	SWAP A, SP	Z	7B	8	2	DEC [X+expr]	C, Z
22	6	2	AND A, [expr]	Z	4F	4	1	MOV X, SP		7C	13	3	LCALL	
23	7	2	AND A, [X+expr]	Z	50	4	2	MOV A, expr	Z	7D	7	3	LJMP	
24	7	2	AND [expr], A	Z	51	5	2	MOV A, [expr]	Z	7E	10	1	RETI	C, Z
25	8	2	AND [X+expr], A	Z	52	6	2	MOV A, [X+expr]	Z	7F	8	1	RET	
26	9	3	AND [expr], expr	Z	53	5	2	MOV [expr], A		8x	5	2	JMP	
27	10	3	AND [X+expr], expr	Z	54	6	2	MOV [X+expr], A		9x	11	2	CALL	
28	11	1	ROMX	Z	55	8	3	MOV [expr], expr		Ax	5	2	JZ	
29	4	2	OR A, expr	Z	56	9	3	MOV [X+expr], expr		Bx	5	2	JNZ	
2A	6	2	OR A, [expr]	Z	57	4	2	MOV X, expr		Cx	5	2	JC	
2B	7	2	OR A, [X+expr]	Z	58	6	2	MOV X, [expr]		Dx	5	2	JNC	
2C	7	2	OR [expr], A	Z	59	7	2	MOV X, [X+expr]		Ex	7	2	JACC	
										Fx	13	2	INDEX	Z

Notes

1. Interrupt routines take 13 cycles before execution resumes at interrupt vector table.
2. The number of cycles required by an instruction is increased by one for instructions that span 256-byte boundaries in the Flash memory space.

Memory Organization

Flash Program Memory Organization

Figure 8. Program Memory Space with Interrupt Vector Table

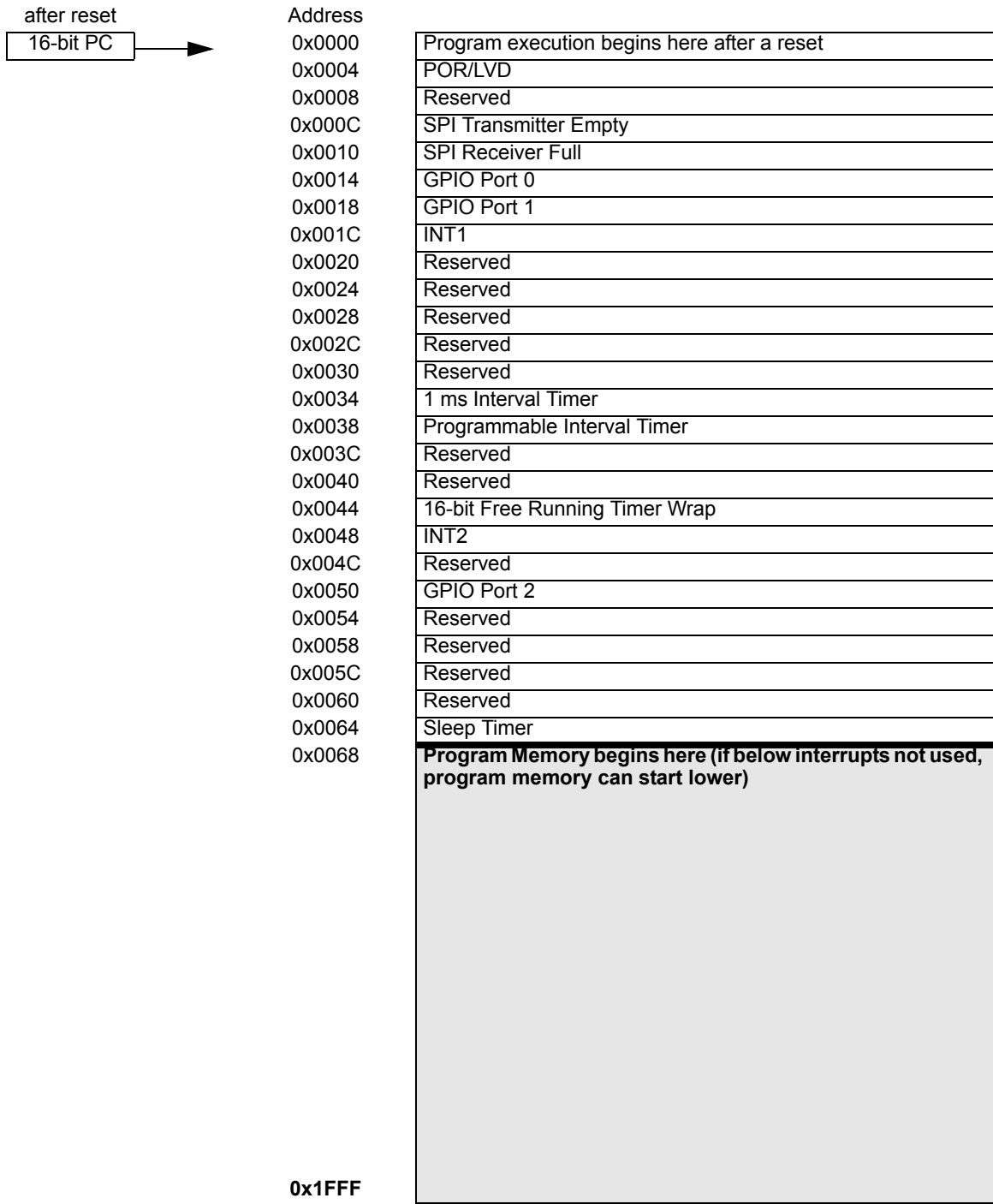

Data Memory Organization

The MCU function provides up to 256 bytes of data RAM.

Figure 9. Data Memory Organization

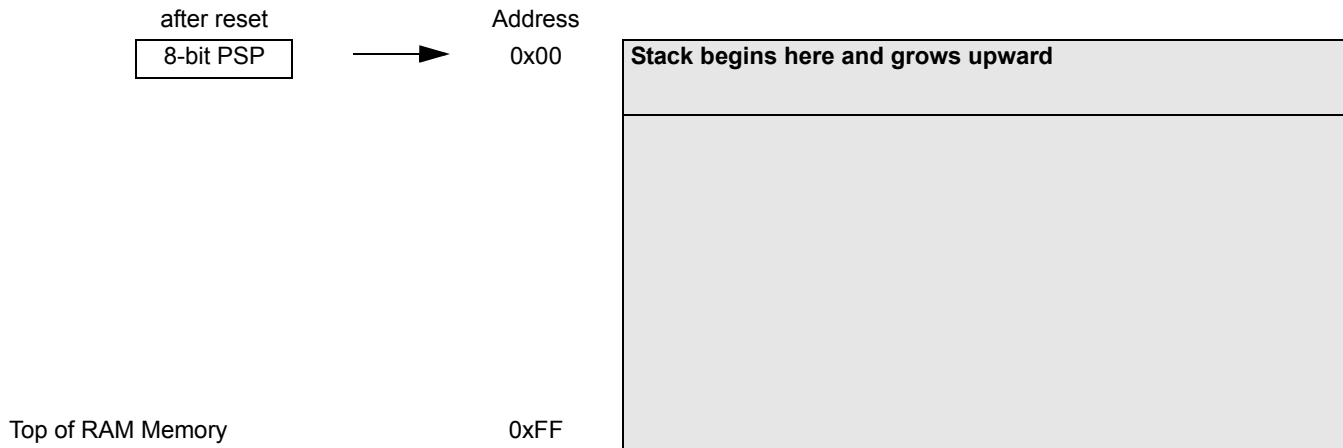

Flash

This section describes the Flash block of the CYRF69103. Much of the user visible Flash functionality, including programming and security, are implemented in the M8C Supervisory Read Only Memory (SROM). CYRF69103 Flash has an endurance of 1000 cycles and 10-year data retention.

Flash Programming and Security

All Flash programming is performed by code in the SROM. The registers that control the Flash programming are only visible to the M8C CPU when it is executing out of SROM. This makes it impossible to read, write, or erase the Flash by bypassing the security mechanisms implemented in the SROM.

Customer firmware can only program the Flash through SROM calls. The data or code images can be sourced by way of any interface with the appropriate support firmware. This type of programming requires a 'bootloader' – a piece of firmware resident on the Flash. For safety reasons, this bootloader must not be over written during firmware rewrites.

The Flash provides four auxiliary rows that are used to hold Flash block protection flags, boot time calibration values, configuration tables, and any device values. The routines for accessing these auxiliary rows are documented in the SROM section. The auxiliary rows are not affected by the device erase function.

In-System Programming

CYRF69103 enables this type of in-system programming by using the P1.0 and P1.1 pins as the serial programming mode interface. This allows an external controller to cause the CYRF69103 to enter serial programming mode and then to use the test queue to issue Flash access functions in the SROM.

SROM

The SROM holds code that is used to boot the part, calibrate circuitry, and perform Flash operations (Table 23 lists the SROM functions). The functions of the SROM may be accessed in normal user code or operating from Flash. The SROM exists in a separate memory space from user code. The SROM functions are accessed by executing the Supervisory System Call instruction (SSC), which has an opcode of 00h. Before executing the SSC, the M8C's accumulator needs to be loaded with the desired SROM function code from Table 23. Undefined functions causes a HALT if called from user code. The SROM functions are executing code with calls; therefore, the functions require stack space. With the exception of Reset, all of the SROM functions have a *parameter block* in SRAM that must be configured before executing the SSC. Table 24 on page 22 lists all possible parameter block variables. The meaning of each parameter, with regards to a specific SROM function, is described later in this section.

Table 23. SROM Function Codes

Function Code	Function Name	Stack Space
00h	SWBootReset	0
01h	ReadBlock	7
02h	WriteBlock	10
03h	EraseBlock	9
05h	EraseAll	11
06h	TableRead	3
07h	CheckSum	3

Two important variables that are used for all functions are KEY1 and KEY2. These variables are used to help discriminate between valid SSCs and inadvertent SSCs. KEY1 must always have a value of 3Ah, while KEY2 must have the same value as the stack pointer when the SROM function begins execution. This is the Stack Pointer value when the SSC opcode is executed, plus three. If either of the keys do not match the expected values, the M8C halts (with the exception of the SWBootReset function). The following code puts the correct value in KEY1 and KEY2. The code starts with a halt, to force the program to jump directly into the setup code and not run into it.

```
halt
SSCOP: mov [KEY1], 3ah
mov X, SP
mov A, X
add A, 3
mov [KEY2], A
```

Table 24. SROM Function Parameters

Variable Name	SRAM Address
Key1/Counter/Return Code	0,F8h
Key2/TMP	0,F9h
BlockID	0,FAh
Pointer	0,FBh
Clock	0,FCh
Mode	0,FDh
Delay	0,FEh
PCL	0,FFh

The SROM also features Return Codes and Lockouts.

Return Codes

Return codes aid in the determination of success or failure of a particular function. The return code is stored in KEY1's position in the parameter block. The CheckSum and TableRead functions do not have return codes because KEY1's position in the parameter block is used to return other data.

Table 25. SROM Return Codes

Return Code	Description
00h	Success
01h	Function not allowed due to level of protection on block
02h	Software reset without hardware reset
03h	Fatal error, SROM halted

Read, write, and erase operations may fail if the target block is read or write protected. Block protection levels are set during device programming.

The EraseAll function overwrites data in addition to leaving the entire user Flash in the erase state. The EraseAll function loops through the number of Flash macros in the product, executing the following sequence: erase, bulk program all zeros, erase. After all the user space in all the Flash macros are erased, a second loop erases and then programs each protection block with zeros.

SROM Function Descriptions

All SROM functions are described in the following sections.

SWBootReset Function

The SROM function, SWBootReset, is the function that is responsible for transitioning the device from a reset state to running user code. The SWBootReset function is executed whenever the SROM is entered with an M8C accumulator value of 00h; the SRAM parameter block is not used as an input to the function. This happens, by design, after a hardware reset, because the M8C's accumulator is reset to 00h or when user code executes the SSC instruction with an accumulator value of 00h. The SWBootReset function does not execute when the SSC instruction is executed with a bad key value and a nonzero function code. A CYRF69103 device executes the HALT instruction if a bad value is given for either KEY1 or KEY2.

The SWBootReset function verifies the integrity of the calibration data by way of a 16-bit checksum, before releasing the M8C to run user code.

ReadBlock Function

The ReadBlock function is used to read 64 contiguous bytes from Flash – a block.

The first thing this function does is to check the protection bits and determine if the desired BLOCKID is readable. If read protection is turned on, the ReadBlock function exits setting the accumulator and KEY2 back to 00h. KEY1 has a value of 01h, indicating a read failure. If read protection is not enabled, the function reads 64 bytes from the Flash using a ROMX instruction and store the results in SRAM using an MVI instruction. The first of the 64 bytes are stored in SRAM at the address indicated by the value of the POINTER parameter. When the ReadBlock completes successfully, the accumulator, KEY1 and KEY2, all have a value of 00h.

Table 26. ReadBlock Parameters

Name	Address	Description
KEY1	0,F8h	3Ah
KEY2	0,F9h	Stack Pointer value, when SSC is executed
BLOCKID	0,FAh	Flash block number
POINTER	0,FBh	First of 64 addresses in SRAM where returned data must be stored

WriteBlock Function

The WriteBlock function is used to store data in the Flash. Data is moved 64 bytes at a time from SRAM to Flash using this function. The first thing the WriteBlock function does is to check the protection bits and determine if the desired BLOCKID is writable. If write protection is turned on, the WriteBlock function exits, setting the accumulator and KEY2 back to 00h. KEY1 has a value of 01h, indicating a write failure. The configuration of the WriteBlock function is straightforward. The BLOCKID of the Flash block, where the data is stored, must be determined and stored at SRAM address FAh.

The SRAM address of the first of the 64 bytes to be stored in Flash must be indicated using the POINTER variable in the

parameter block (SRAM address FBh). Finally, the CLOCK and DELAY values must be set correctly. The CLOCK value determines the length of the write pulse that is used to store the data in the Flash. The CLOCK and DELAY values are dependent on the CPU. Refer to 'Clocking' Section for additional information.

Table 27. WriteBlock Parameters

Name	Address	Description
KEY1	0,F8h	3Ah
KEY2	0,F9h	Stack Pointer value, when SSC is executing
BLOCK ID	0,FAh	8 KB Flash block number (00h–7Fh) 4 KB Flash block number (00h–3Fh) 3 KB Flash block number (00h–2Fh)
POINTER	0,FBh	First 64 addresses in SRAM where the data to be stored in Flash is located before calling WriteBlock
CLOCK	0,FCh	Clock Divider used to set the write Pulse width
DELAY	0,FEh	For a CPU speed of 12 MHz set to 56h

EraseBlock Function

The EraseBlock function is used to erase a block of 64 contiguous bytes in Flash. The first thing the EraseBlock function does is to check the protection bits and determine if the desired BLOCKID is writable. If write protection is turned on, the EraseBlock function exits, setting the accumulator and KEY2 back to 00h. KEY1 has a value of 01h, indicating a write failure. The EraseBlock function is only useful as the first step in programming. Erasing a block does not cause data in a block to be one hundred percent unreadable. If the objective is to obliterate data in a block, the best method is to perform an EraseBlock followed by a WriteBlock of all zeros.

To set up the parameter block for the EraseBlock function, correct key values must be stored in KEY1 and KEY2. The block number to be erased must be stored in the BLOCKID variable and the CLOCK and DELAY values must be set based on the current CPU speed.

Table 28. EraseBlock Parameters

Name	Address	Description
KEY1	0,F8h	3Ah
KEY2	0,F9h	Stack Pointer value when SSC is executed
BLOCKID	0,FAh	Flash block number (00h–7Fh)
CLOCK	0,FCh	Clock Divider used to set the erase pulse width
DELAY	0,FEh	For a CPU speed of 12 MHz set to 56h

ProtectBlock Function

The CYRF69103 device offers Flash protection on a block-by-block basis. Table 29 lists the protection modes

available. In the table, ER and EW are used to indicate the ability to perform external reads and writes. For internal writes, IW is used. Internal reading is always permitted by way of the ROMX instruction. The ability to read by way of the SRAM ReadBlock function is indicated by SR. The protection level is stored in two bits, according to Table 29. These bits are bit packed into the 64 bytes of the protection block. Therefore, each protection block byte stores the protection level for four Flash blocks. The bits are packed into a byte, with the lowest numbered block's protection level stored in the lowest numbered bits.

The first address of the protection block contains the protection level for blocks 0 through 3; the second address is for blocks 4 through 7. The 64th byte stores the protection level for blocks 252 through 255.

Table 29. Protection Modes

Mode	Settings	Description	Marketing
00b	SR ER EW IW	Unprotected	Unprotected
01b	SR ER EW IW	Read protect	Factory upgrade
10b	SR ER EW IW	Disable external write	Field upgrade
11b	SR ER EW IW	Disable internal write	Full protection

7	6	5	4	3	2	1	0
Block n+3		Block n+2		Block n+1		Block n	

The level of protection is only decreased by an EraseAll, which places zeros in all locations of the protection block. To set the level of protection, the ProtectBlock function is used. This function takes data from SRAM, starting at address 80h, and ORs it with the current values in the protection block. The result of the OR operation is then stored in the protection block. The EraseBlock function does not change the protection level for a block. Because the SRAM location for the protection data is fixed and there is only one protection block per Flash macro, the ProtectBlock function expects very few variables in the parameter block to be set before calling the function. The parameter block values that must be set, besides the keys, are the CLOCK and DELAY values.

Table 30. ProtectBlock Parameters

Name	Address	Description
KEY1	0,F8h	3Ah
KEY2	0,F9h	Stack Pointer value when SSC is executed
CLOCK	0,FCh	Clock Divider used to set the write pulse width
DELAY	0,FEh	For a CPU speed of 12 MHz set to 56h

EraseAll Function

The EraseAll function performs a series of steps that destroy the user data in the Flash macros and resets the protection block in each Flash macro to all zeros (the unprotected state). The EraseAll function does not affect the three hidden blocks above

the protection block in each Flash macro. The first of these four hidden blocks is used to store the protection table for its eight Kbytes of user data.

The EraseAll function begins by erasing the user space of the Flash macro with the highest address range. A bulk program of all zeros is then performed on the same Flash macro, to destroy all traces of the previous contents. The bulk program is followed by a second erase that leaves the Flash macro in a state ready for writing. The erase, program, erase sequence is then performed on the next lowest Flash macro in the address space if it exists. Following the erase of the user space, the protection block for the Flash macro with the highest address range is erased. Following the erase of the protection block, zeros are written into every bit of the protection table. The next lowest Flash macro in the address space then has its protection block erased and filled with zeros.

The end result of the EraseAll function is that all user data in the Flash is destroyed and the Flash is left in an unprogrammed state, ready to accept one of the various write commands. The protection bits for all user data are also reset to the zero state.

The parameter block values that must be set, besides the keys, are the CLOCK and DELAY values.

Table 31. EraseAll Parameters

Name	Address	Description
KEY1	0,F8h	3Ah
KEY2	0,F9h	Stack Pointer value when SSC is executed
CLOCK	0,FCh	Clock Divider used to set the write pulse width
DELAY	0,FEh	For a CPU speed of 12 MHz set to 56h

TableRead Function

The TableRead function gives the user access to part specific data stored in the Flash during manufacturing. It also returns a Revision ID for the die (not to be confused with the Silicon ID).

Table 32. Table Read Parameters

Name	Address	Description
KEY1	0,F8h	3Ah
KEY2	0,F9h	Stack Pointer value when SSC is executed
BLOCKID	0,FAh	Table number to read

The table space for the CYRF69103 is simply a 64 byte row broken up into eight tables of eight bytes. The tables are

numbered zero through seven. All user and hidden blocks in the CYRF69103 consist of 64 bytes.

An internal table holds the Silicon ID and returns the Revision ID. The Silicon ID is returned in SRAM, while the Revision ID is returned in the CPU_A and CPU_X registers. The Silicon ID is a value placed in the table by programming the Flash and is controlled by Cypress Semiconductor Product Engineering. The Revision ID is hard coded into the SROM. The Revision ID is discussed in more detail later in this section.

An internal table holds alternate trim values for the device and returns a one-byte internal revision counter. The internal revision counter starts out with a value of zero and is incremented each time one of the other revision numbers is not incremented. It is reset to zero each time one of the other revision numbers is incremented. The internal revision count is returned in the CPU_A register. The CPU_X register is always set to FFh when trim values are read. The BLOCKID value, in the parameter block, is used to indicate which table must be returned to the user. Only the three least significant bits of the BLOCKID parameter are used by the TableRead function for the CYRF69103. The upper five bits are ignored. When the function is called, it transfers bytes from the table to SRAM addresses F8h–FFh.

The M8C's A and X registers are used by the TableRead function to return the die's Revision ID. The Revision ID is a 16-bit value hard coded into the SROM that uniquely identifies the die's design.

Checksum Function

The Checksum function calculates a 16-bit checksum over a user specifiable number of blocks, within a single Flash macro (Bank) starting from block zero. The BLOCKID parameter is used to pass in the number of blocks to calculate the checksum over. A BLOCKID value of 1 calculates the checksum of only block 0, while a BLOCKID value of 0 calculates the checksum of all 256 user blocks. The 16-bit checksum is returned in KEY1 and KEY2. The parameter KEY1 holds the lower eight bits of the checksum and the parameter KEY2 holds the upper eight bits of the checksum.

The checksum algorithm executes the following sequence of three instructions over the number of blocks times 64 to be checksummed.

```
romx
add [KEY1], A
adc [KEY2], 0
```

Table 33. Checksum Parameters

Name	Address	Description
KEY1	0,F8h	3Ah
KEY2	0,F9h	Stack Pointer value when SSC is executed
BLOCKID	0,FAh	Number of Flash blocks to calculate checksum on

Clocking

The CYRF69103 internal oscillator outputs two frequencies, the Internal 24 MHz Oscillator and the 32 kHz Low power Oscillator.

The Internal 24 MHz Oscillator is designed such that it may be trimmed to an output frequency of 24 MHz over temperature and voltage variation. The Internal 24 MHz Oscillator accuracy is 24 MHz -22% to +10% (between 0 °C-70 °C). No external components are required to achieve this level of accuracy.

Firmware is responsible for selecting the correct trim values from the User row to match the power supply voltage in the end application and writing the values to the trim registers IOSCTR and LPOSCTR.

The internal low speed oscillator of nominally 32 kHz provides a slow clock source for the CYRF69103 in suspend mode. This is used to generate a periodic wakeup interrupt and provide a clock to sequential logic during power up and power down events when the main clock is stopped. In addition, this oscillator can

also be used as a clocking source for the Interval Timer clock (ITMRCLK) and Capture Timer clock (TCAPCLK). The 32 kHz Low power Oscillator can operate in low power mode or can provide a more accurate clock in normal mode. The Internal 32 kHz Low power Oscillator accuracy ranges from -53.12% to +56.25%. The 32 kHz low power oscillator can be calibrated against the internal 24 MHz oscillator or another timing source if desired.

CYRF69103 provides the ability to load new trim values for the 24 MHz oscillator based on voltage. This allows Vdd to be monitored and have firmware trim the oscillator based on voltage present. The IOSCTR register is used to set trim values for the 24 MHz oscillator. CYRF69103 is initialized with 3.30V trim values at power on, then firmware is responsible for transferring the correct set of trim values to the trim registers to match the application's actual Vdd. The 32 kHz oscillator generally does not require trim adjustments versus voltage but trim values for the 32 kHz are also stored in Supervisory ROM.

Figure 10. SROM Table

	F8h	F9h	FAh	FBh	FCh	FDh	FEh	FFh
Table 0	Silicon ID [15-8]	Silicon ID [7-0]						
Table 1								
Table 2					24 MHz IOSCTR at 3.30V	24 MHz IOSCTR at 3.00V	24 MHz IOSCTR at 2.85V	24 MHz IOSCTR at 2.70V
Table 3	32 kHz LPOSCTR at 3.30V	32 kHz LPOSCTR at 3.00V	32 kHz LPOSCTR at 2.85V	32 kHz LPOSCTR at 2.70V				
Table 4								
Table 5								
Table 6								
Table 7								

To improve the accuracy of the IMO, new trim values are loaded based on supply voltage to the part. For this, firmware needs to make modifications to two registers:

1. The internal oscillator trim register at location 0x34.
2. The gain register at location 0x38.

Trim values for the IOSCTR register:

The trim values are stored in SROM tables in the part as shown in [Figure 10](#) on page 25.

The trim values are read out from the part based on voltage settings and written to the IOSCTR register at location 0x34. The following pseudo code shows how this is done.

```
_main:
    mov     A, 2
    mov     [SSC_BLOCKID], A
Call SROM operation to read the SROM table (Refer to section SROM Table Read Description)
//After this command is executed, the trim values for 3.3, 3.0, 2.85 and 2.7 are stored at locations
FC through FF in the RAM. SROM calls are explained in the previous section of this datasheet
;         mov     A, [FCh]                // trim values for 3.3V
;         mov     A, [FDh]                // trim values for 3.0V
;         mov     A, [FEh]                // trim values for 2.85V
;         mov     A, [FFh]                // trim values for 2.70V
    mov     reg[IOSCTR],A // Loading IOSCTR with trim values for 3.0V
.terminate:
    jmp .terminate
```

SROM Table Read Description

The Silicon IDs for CYRF69103 devices are stored in SROM tables in the part, as shown in [Figure 10](#) on page 25.

The Silicon ID can be read out from the part using SROM Table reads. This is demonstrated in the following pseudo code. As mentioned in the section [SROM](#) on page 21, the SROM variables occupy address F8h through FFh in the SRAM. Each of the variables and their definition is given in the section [SROM](#) on page 21.

```
AREA SSCParmBlkA (RAM,ABS)

    org     F8h // Variables are defined starting at address F8h

SSC_KEY1:                ; F8h  supervisory key
SSC_RETURNCODE:         blk 1 ; F8h  result code
SSC_KEY2 :              blk 1 ; F9h  supervisory stack ptr key
SSC_BLOCKID:           blk 1 ; FAh  block ID
SSC_POINTER:          blk 1 ; FBh  pointer to data buffer
SSC_CLOCK:            blk 1 ; FCh  Clock
SSC_MODE:             blk 1 ; FDh  ClockW ClockE multiplier
SSC_DELAY:            blk 1 ; FEh  flash macro sequence delay count
SSC_WRITE_ResultCode: blk 1 ; FFh  temporary result code

_main:
    mov     A, 0
    mov     [SSC_BLOCKID], A // To read from Table 0 - Silicon ID is stored in Table 0
//Call SROM operation to read the SROM table
    mov     X, SP        ; copy SP into X
    mov     A, X         ; A temp stored in X
    add     A, 3         ; create 3 byte stack frame (2 + pushed A)
    mov     [SSC_KEY2], A ; save stack frame for supervisory code

; load the supervisory code for flash operations
    mov     [SSC_KEY1], 3Ah ;FLASH_OPER_KEY - 3Ah

    mov     A,6         ; load A with specific operation. 06h is the code for Table read Table
23 on page 21
    SSC                    ; SSC call the supervisory ROM

// At the end of the SSC command the silicon ID is stored in F8 (MSB) and F9(LSB) of the SRAM

.terminate:
    jmp .terminate
```

Gain value for the register at location [0x38]:

3.3 V = 0x40

3.0 V = 0x40

2.85 V = 0xFF

2.70 V = 0xFF

Load register [0x38] with the gain values corresponding to the appropriate voltage.

Table 34. Oscillator Trim Values vs. Voltage Settings

Supervisory ROM Table	Function
Table2 FCh	24 MHz IOSCTR at 3.30 V
Table2 FDh	24 MHz IOSCTR at 3.00 V
Table2 FEh	24 MHz IOSCTR at 2.85 V
Table2 FFh	24 MHz IOSCTR at 2.70 V
Table3 F8h	32 kHz LPOSCTR at 3.30 V
Table3 F9h	32 kHz LPOSCTR at 3.00 V
Table3 FAh	32 kHz LPOSCTR at 2.85 V
Table3 FBh	32 kHz LPOSCTR at 2.70 V

When using the 32 kHz oscillator the PITMRL/H must be read until two consecutive readings match before sending/receiving data. The following firmware example assumes the developer is interested in the lower byte of the PIT.

```

Read_PIT_counter:
mov A, reg[PITMRL]
mov [57h], A

```

```

mov A, reg[PITMRL]
mov [58h],A
mov [59h], A
mov A, reg[PITMRL]
mov [60h], A
;;;Start comparison
mov A,[60h]
mov X, [59h]
sub A, [59h]
jz done
mov A, [59h]
mov X, [58h]
sub A, [58h]
jz done
mov X, [57h]
;;;correct data is in memory location 57h
done:
mov [57h], X
ret

```

Clock Architecture Description

The CYRF69103 clock selection circuitry allows the selection of independent clocks for the CPU, Interval Timers, and Capture Timers.

CPU Clock

The CPU clock, CPUCLK, can be sourced from the Internal 24 MHz oscillator. The selected clock source can optionally be divided by 2^{n-1} where n is 0–7 (see Table 36 on page 28).

Table 35. CPU Clock Config (CPUCLKCR) [0x30] [R/W]

Bit #	7	6	5	4	3	2	1	0
Field	Reserved							
Read/Write	–	–	–	–	–	–	–	–
Default	0	0	0	0	0	0	0	0

Bits 7:0 Reserved

Note The CPU speed selection is configured using the OSC_CR0 Register (Figure 11 on page 30).

Table 36. OSC Control 0 (OSC_CR0) [0x1E0] [R/W]

Bit #	7	6	5	4	3	2	1	0
Field	Reserved		No Buzz	Sleep Timer [1:0]		CPU Speed [2:0]		
Read/Write	–	–	R/W	R/W	R/W	R/W	R/W	R/W
Default	0	0	0	0	1	0	0	0

Bits 7:6 Reserved

Bit 5 No Buzz

During sleep (the Sleep bit is set in the CPU_SCR Register—[Table 40](#) on page 32), the LVD and POR detection circuit is turned on periodically to detect any POR and LVD events on the V_{CC} pin (the Sleep Duty Cycle bits in the ECO_TR are used to control the duty cycle—[Table 44](#) on page 37). To facilitate the detection of POR and LVD events, the No Buzz bit is used to force the LVD and POR detection circuit to be continuously enabled during sleep. This results in a faster response to an LVD or POR event during sleep at the expense of a slightly higher than average sleep current. Obtaining the absolute lowest power usage in sleep mode requires the No Buzz bit be clear

0 = The LVD and POR detection circuit is turned on periodically as configured in the Sleep Duty Cycle.

1 = The Sleep Duty Cycle value is overridden. The LVD and POR detection circuit is always enabled.

Note The periodic Sleep Duty Cycle enabling is independent with the sleep interval shown in the following Sleep [1:0] bits.

Bits 4:3 Sleep Timer [1:0]

Sleep Timer [1:0]	Sleep Timer Clock Frequency (Nominal)	Sleep Period (Nominal)	Watchdog Period (Nominal)
00	512 Hz	1.95 ms	6 ms
01	64 Hz	15.6 ms	47 ms
10	8 Hz	125 ms	375 ms
11	1 Hz	1 sec	3 sec

Note Sleep intervals are approximate

Bits 2:0 CPU Speed [2:0]

The CYRF69103 may operate over a range of CPU clock speeds. The reset value for the CPU Speed bits is zero. Therefore, the default CPU speed is 3 MHz.

CPU Speed [2:0]	CPU when Internal Oscillator is selected
000	3 MHz (Default)
001	6 MHz
010	12 MHz
011	Reserved
100	1.5 MHz
101	750 kHz
110	187 kHz
111	Reserved

Table 37. Timer Clock Config (TMRCLKCR) [0x31] [R/W]

Bit #	7	6	5	4	3	2	1	0
Field	TCAPCLK Divider		TCAPCLK Select		ITMRCLK Divider		ITMRCLK Select	
Read/Write	R/W	R/W	R/W	R/W	R/W	R/W	R/W	R/W
Default	1	0	0	0	1	1	1	1

Bits 7:6 TCAPCLK Divider [1:0]
 TCAPCLK Divider controls the TCAPCLK divisor.
 0 0 = Divider Value 2
 0 1 = Divider Value 4
 1 0 = Divider Value 6
 1 1 = Divider Value 8

Bits 5:4 TCAPCLK Select
 The TCAPCLK Select field controls the source of the TCAPCLK.
 0 0 = Internal 24 MHz Oscillator
 0 1 =Reserved
 1 0 = Internal 32 kHz Low power Oscillator
 1 1 = TCAPCLK Disabled

Note The 1024 μ s interval timer is based on the assumption that TCAPCLK is running at 4 MHz. Changes in TCAPCLK frequency cause a corresponding change in the 1024 μ s interval timer frequency.

Bits 3:2 ITMRCLK Divider
 ITMRCLK Divider controls the ITMRCLK divisor
 0 0 = Divider value of 1
 0 1 = Divider value of 2
 1 0 = Divider value of 3
 1 1 = Divider value of 4

Bits 1:0 ITMRCLK Select
 0 0 = Internal 24 MHz Oscillator
 0 1 = Reserved
 1 0 = Internal 32 kHz Low power Oscillator
 1 1 = TCAPCLK

Note Changing the source of TMRCLK requires that both the source and destination clocks be running. Attempting to change the clock source away from TCAPCLK after that clock has been stopped is not successful.

Interval Timer Clock (ITMRCLK)

The Interval Timer clock (ITMRCLK) can be sourced from the internal 24 MHz oscillator, internal 32 kHz low power oscillator, or timer capture clock. A programmable prescaler of 1, 2, 3, or 4 then divides the selected source. The 12-bit Programmable Interval Timer is a simple down counter with a programmable reload value. It provides a 1 μ s resolution by default. When the down counter reaches zero, the next clock is spent reloading. The reload value can be read and written while the counter is running, but care must be taken to ensure that the counter does not unintentionally reload while the 12-bit reload value is only partially stored – for example, between the two writes of the 12-bit value. The programmable interval timer generates interrupt to the CPU on each reload.

The parameters to be set appears on the device editor view of PSoC Designer after you place the CYRF69103 timer user module. The parameters are PITIMER_Source and PITIMER_Divider. The PITIMER_Source is the clock to the timer and the PITIMER_Divider is the value the clock is divided by.

The interval register (PITMR) holds the value that is loaded into the PIT counter on terminal count. The PIT counter is a down counter.

The Programmable Interval Timer resolution is configurable. For example:

TCAPCLK divide by x of CPU clock (for example TCAPCLK divide by 2 of a 24 MHz CPU clock gives a frequency of 12 MHz)

ITMRCLK divide by x of TCAPCLK (for example, ITMRCLK divide by 3 of TCAPCLK is 4 MHz so resolution is 0.25 μ s).

Timer Capture Clock (TCAPCLK)

The Timer Capture clock (TCAPCLK) can be sourced from the internal 24 MHz oscillator or the internal 32 kHz low power oscillator. A programmable prescaler of 2, 4, 6, or 8 then divides the selected source.

Figure 11. Programmable Interval Timer Block Diagram

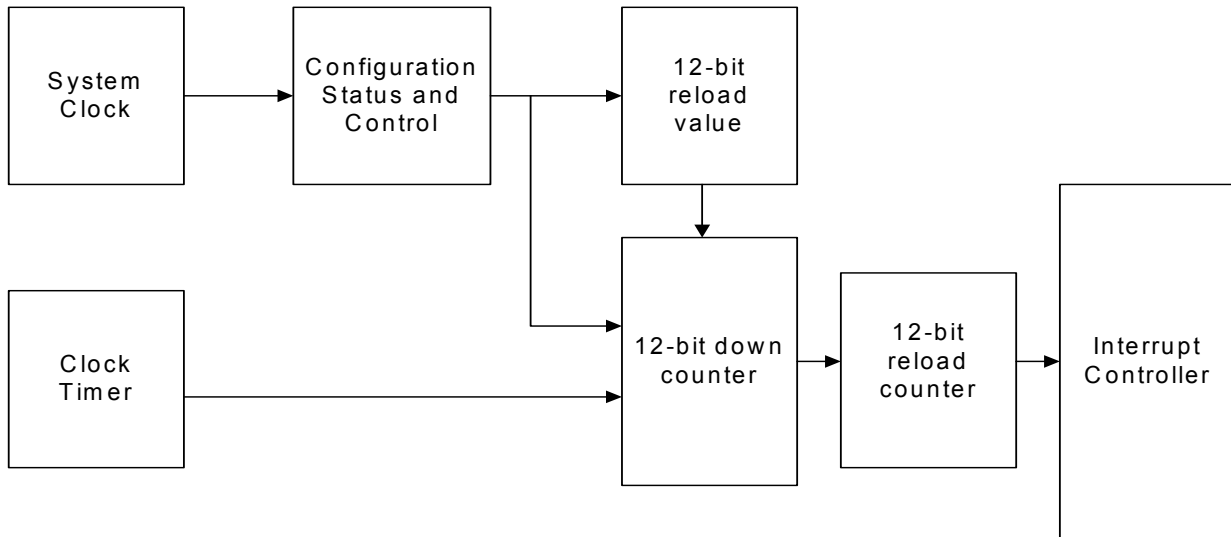

Internal Clock Trim

Table 38. IOISC Trim (IOSCTR) [0x34] [R/W]

Bit #	7	6	5	4	3	2	1	0
Field	ffset[2:0]			Gain[4:0]				
Read/Write	R/W	R/W	R/W	R/W	R/W	R/W	R/W	R/W
Default	0	0	0	D	D	D	D	D

The IOISC Calibrate register is used to calibrate the internal oscillator. The reset value is undefined but during boot the SROM writes a calibration value that is determined during manufacturing test. The 'D' indicates that the default value is trimmed to 24 MHz at 3.30V at power on.

Bits 7:5 fffset [2:0]

This value is used to trim the frequency of the internal oscillator. These bits are not used in factory calibration and are zero. Setting each of these bits causes the appropriate fine offset in oscillator frequency:

- ffset bit 0 = 7.5 kHz
- ffset bit 1 = 15 kHz
- ffset bit 2 = 30 kHz

Bits 4:0 Gain [4:0]

The effective frequency change of the offset input is controlled through the gain input. A lower value of the gain setting increases the gain of the offset input. This value sets the size of each offset step for the internal oscillator. Nominal gain change (kHz/offsetStep) at each bit, typical conditions (24 MHz operation):

- Gain bit 0 = -1.5 kHz
- Gain bit 1 = -3.0 kHz
- Gain bit 2 = -6 kHz
- Gain bit 4 = -24 kHz

LPOSC Trim
Table 39. LPOSC Trim (LPOSCTR) [0x36] [R/W]

Bit #	7	6	5	4	3	2	1	0
Field	32 kHz Low Power	Reserved	32 kHz Bias Trim [1:0]		32 kHz Freq Trim [3:0]			
Read/Write	R/W	–	R/W	R/W	R/W	R/W	R/W	R/W
Default	0	–	D	D	D	D	D	D

This register is used to calibrate the 32 kHz Low speed Oscillator. The reset value is undefined but during boot the SROM writes a calibration value that is determined during manufacturing test. This is the meaning of 'D' in the Default field. The trim value can be adjusted vs. voltage as noted in [Table 35](#) on page 27.

Bit 7 32 kHz Low Power
 0 = The 32 kHz Low speed Oscillator operates in normal mode.
 1 = The 32 kHz Low speed Oscillator operates in a low power mode. The oscillator continues to function normally but with reduced accuracy.

Bit 6 Reserved

Bits [5:4] 32 kHz Bias Trim [1:0]
 These bits control the bias current of the low power oscillator.
 0 0 = Mid bias
 0 1 = High bias
 1 0 = Reserved
 1 1 = Reserved

Important Note Do not program the 32 kHz Bias Trim [1:0] field with the reserved 10b value as the oscillator does not oscillate at all corner conditions with this setting.

Bits 3:0 32 kHz Freq Trim [3:0]
 These bits are used to trim the frequency of the low power oscillator.

CPU Clock During Sleep Mode

When the CPU enters sleep mode, the oscillator is stopped. When the CPU comes out of sleep mode it is running on the internal oscillator. The internal oscillator recovery time is three clock cycles of the Internal 32 kHz Low power Oscillator.

Reset

The microcontroller supports two types of resets: Power on Reset (POR) and Watchdog Reset (WDR). When reset is initiated, all registers are restored to their default states and all interrupts are disabled.

The occurrence of a reset is recorded in the System Status and Control Register (CPU_SCR). Bits within this register record the occurrence of POR and WDR Reset respectively. The firmware can interrogate these bits to determine the cause of a reset.

The microcontroller resumes execution from Flash address 0x0000 after a reset. The internal clocking mode is active after a reset, until changed by user firmware.

Note The CPU clock defaults to 3 MHz (Internal 24 MHz Oscillator divide-by-8 mode) at POR to guarantee operation at the low V_{CC} that might be present during the supply ramp.

Table 40. System Status and Control Register (CPU_SCR) [0xFF] [R/W]

Bit #	7	6	5	4	3	2	1	0
Field	GIES	Reserved	WDRS	PORS	Sleep	Reserved	Reserved	Stop
Read/Write	R	–	R/C ^[3]	R/C ^[3]	R/W	–	–	R/W
Default	0	0	0	1	0	1	0	0

The bits of the CPU_SCR register are used to convey status and control of events for various functions of a CYRF69103 device.

- Bit 7** GIES
 The Global Interrupt Enable Status bit is a read-only status bit and its use is discouraged. The GIES bit is a legacy bit, which was used to provide the ability to read the GIE bit of the CPU_F register. However, the CPU_F register is now readable. When this bit is set, it indicates that the GIE bit in the CPU_F register is also set which, in turn, indicates that the microprocessor services interrupts:
 0 = Global interrupts disabled
 1 = Global interrupt enabled
- Bit 6** Reserved
- Bit 5** WDRS
 The WDRS bit is set by the CPU to indicate that a WDR event has occurred. The user can read this bit to determine the type of reset that has occurred. The user can clear but not set this bit:
 0 = No WDR
 1 = A WDR event has occurred
- Bit 4** PORS
 The PORS bit is set by the CPU to indicate that a POR event has occurred. The user can read this bit to determine the type of reset that has occurred. The user can clear but not set this bit:
 0 = No POR
 1 = A POR event has occurred (Note that WDR events do not occur until this bit is cleared).
- Bit 3** SLEEP
 Set by the user to enable CPU sleep state. CPU remains in sleep mode until any interrupt is pending. The Sleep bit is covered in more detail in the section [Sleep Mode](#) on page 33.
 0 = Normal operation
 1 = Sleep
- Bits 2:1** Reserved
- Bit 0** STOP
 This bit is set by the user to halt the CPU. The CPU remains halted until a reset (WDR, POR, or external reset) has taken place. If an application wants to stop code execution until a reset, the preferred method is to use the HALT instruction rather than writing to this bit.
 0 = Normal CPU operation
 1 = CPU is halted (not recommended)

Note

3. C = Clear. This bit can only be cleared by the user and cannot be set by firmware.

Power On Reset

POR occurs every time the power to the device is switched on. POR is released when the supply is typically 2.6 V for the upward supply transition, with typically 50 mV of hysteresis during the power on transient. Bit 4 of the System Status and Control Register (CPU_SCR) is set to record this event (the register contents are set to 00010000 by the POR). After a POR, the microprocessor is held off for approximately 20 ms for the V_{CC} supply to stabilize before executing the first instruction at address 0x00 in the Flash. If the V_{CC} voltage drops below the POR downward supply trip point, POR is reasserted. The V_{CC} supply needs to ramp linearly from 0 to V_{CC} in 0 to 200 ms.

Important The PORS status bit is set at POR and can only be cleared by the user, and cannot be set by firmware.

Watchdog Timer Reset

The user has the option to enable the WDT. The WDT is enabled by clearing the PORS bit. When the PORS bit is cleared, the

WDT cannot be disabled. The only exception to this is if a POR event takes place, which disables the WDT.

The sleep timer is used to generate the sleep time period and the Watchdog time period. The sleep timer uses the Internal 32 kHz Low power Oscillator system clock to produce the sleep time period. The user can program the sleep time period using the Sleep Timer bits of the OSC_CR0 Register (Table 36 on page 28). When the sleep time elapses (sleep timer overflows), an interrupt to the Sleep Timer Interrupt Vector is generated.

The Watchdog Timer period is automatically set to be three counts of the Sleep Timer overflows. This represents between two and three sleep intervals depending on the count in the Sleep Timer at the previous WDT clear. When this timer reaches three, a WDR is generated.

The user can either clear the WDT, or the WDT and the Sleep Timer. Whenever the user writes to the Reset WDT Register (RES_WDT), the WDT is cleared. If the data that is written is the hex value 0x38, the Sleep Timer is also cleared at the same time.

Table 41. Reset Watchdog Timer (RESWDT) [0xE3] [W]

Bit #	7	6	5	4	3	2	1	0
Field	Reset Watchdog Timer [7:0]							
Read/Write	W	W	W	W	W	W	W	W
Default	0	0	0	0	0	0	0	0

Any write to this register clears the Watchdog Timer, a write of 0x38 also clears the Sleep Timer.

Bits 7:0 Reset Watchdog Timer [7:0]

Sleep Mode

The CPU can only be put to sleep by the firmware. This is accomplished by setting the Sleep bit in the System Status and Control Register (CPU_SCR). This stops the CPU from executing instructions, and the CPU remains asleep until an interrupt comes pending, or there is a reset event (either a Power on Reset, or a Watchdog Timer Reset).

The Low voltage Detection circuit (LVD) drops into fully functional power reduced states, and the latency for the LVD is increased. The actual latency can be traded against power consumption by changing the Sleep Duty Cycle field of the ECO_TR Register.

The Internal 32 kHz low speed oscillator remains running. Before entering suspend mode, firmware can optionally configure the 32 kHz Low speed Oscillator to operate in a low power mode to help reduce the overall power consumption (using the 32 kHz Low Power bit, Table 39). This helps save approximately 5 μA; however, the trade off is that the 32 kHz Low speed Oscillator be less accurate (-53.12% to +56.25% deviation).

All interrupts remain active. Only the occurrence of an interrupt wakes the part from sleep. The Stop bit in the System Status and Control Register (CPU_SCR) must be cleared for a part to resume out of sleep. The Global Interrupt Enable bit of the CPU Flags Register (CPU_F) does not have any effect. Any unmasked interrupt wakes the system up. As a result, any interrupts not intended for waking must be disabled through the Interrupt Mask Registers.

When the CPU enters sleep mode, the internal oscillator is stopped. When the CPU comes out of sleep mode, it is running on the internal oscillator. The internal oscillator recovery time is three clock cycles of the Internal 32 kHz Low power Oscillator.

On exiting sleep mode, when the clock is stable and the delay time has expired, the instruction immediately following the sleep instruction is executed before the interrupt service routine (if enabled).

The Sleep interrupt allows the microcontroller to wake up periodically and poll system components while maintaining very low average power consumption. The Sleep interrupt may also be used to provide periodic interrupts during non sleep modes.

Sleep Sequence

The Sleep bit is an input into the sleep logic circuit. This circuit is designed to sequence the device into and out of the hardware sleep state. The hardware sequence to put the device to sleep is shown in Figure 12 on page 34 and is defined as follows.

1. Firmware sets the SLEEP bit in the CPU_SCR0 register. The Bus Request (BRQ) signal to the CPU is immediately asserted. This is a request by the system to halt CPU operation at an instruction boundary. The CPU samples BRQ on the positive edge of CPUCLK.
2. Due to the specific timing of the register write, the CPU issues a Bus Request Acknowledge (BRA) on the following positive edge of the CPU clock. The sleep logic waits for the following negative edge of the CPU clock and then asserts a system-wide Power Down (PD) signal. In Figure 12 on page 34 the CPU is halted and the system-wide power down signal is asserted.

3. The system-wide PD (power down) signal controls several major circuit blocks: The Flash memory module, the internal 24 MHz oscillator, the EFTB filter and the bandgap voltage reference. These circuits transition into a zero power state. The only operational circuits on chip are the Low Power oscillator, the bandgap refresh circuit, and the supply voltage monitor (POR/LVD) circuit.

Low Power in Sleep Mode

To achieve the lowest possible power consumption during suspend or sleep, the following conditions are observed in addition to considerations for the sleep timer:

- All GPIOs are set to outputs and driven low
- Clear P11CR[0], P10CR[0]

- Set P10CR[1]
- To avoid current consumption make sure ITMRCLK and TCPCLK are not sourced by either low power 32 kHz oscillator or 24 MHz crystal-less oscillator.

All the other blocks go to the power down mode automatically on suspend.

The following steps are user configurable and help in reducing the average suspend mode power consumption:

1. Configure the power supply monitor at a large regular intervals, control register bits are 1,EB[7:6] (Power system sleep duty cycle PSSDC[1:0]).
2. Configure the Low power oscillator into low power mode, control register bit is LOPSCTR[7].

Figure 12. Sleep Timing

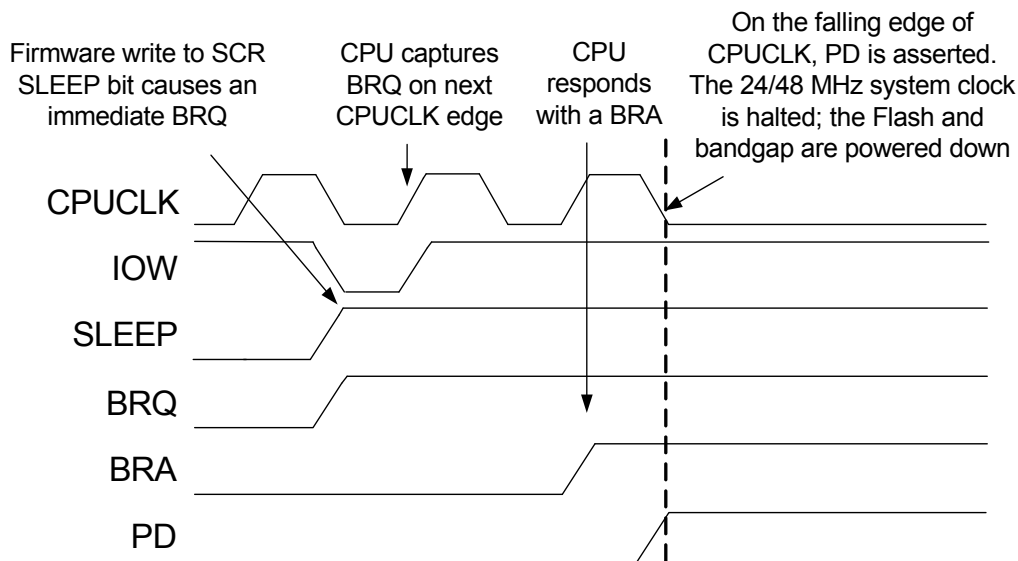

Wakeup Sequence

When asleep, the only event that can wake the system up is an interrupt. The global interrupt enable of the CPU flag register does not need to be set. Any unmasked interrupt wakes the system up. It is optional for the CPU to actually take the interrupt after the wakeup sequence. The wakeup sequence is synchronized to the 32 kHz clock. This is done to sequence a startup delay and enable the Flash memory module enough time to power up before the CPU asserts the first read access. Another reason for the delay is to enable the oscillator, Bandgap, and LVD/POR circuits time to settle before actually being used in the system. As shown in Figure 13 on page 35, the wakeup sequence is as follows:

1. The wakeup interrupt occurs and is synchronized by the negative edge of the 32 kHz clock.
2. At the following positive edge of the 32 kHz clock, the system-wide PD signal is negated. The Flash memory

module, internal oscillator, EFTB, and bandgap circuit are all powered up to a normal operating state.

3. At the following positive edge of the 32 kHz clock, the current values for the precision POR and LVD have settled and are sampled.
4. At the following negative edge of the 32 kHz clock (after about 15 μs nominal), the BRQ signal is negated by the sleep logic circuit. On the following CPUCLK, BRA is negated by the CPU and instruction execution resumes. Note that in Figure 13 on page 35 fixed function blocks, such as Flash, internal oscillator, EFTB, and bandgap, have about 15 μs start up. The wakeup times (interrupt to CPU operational) ranges from 75 μs to 105 μs.

Figure 13. Wakeup Timing

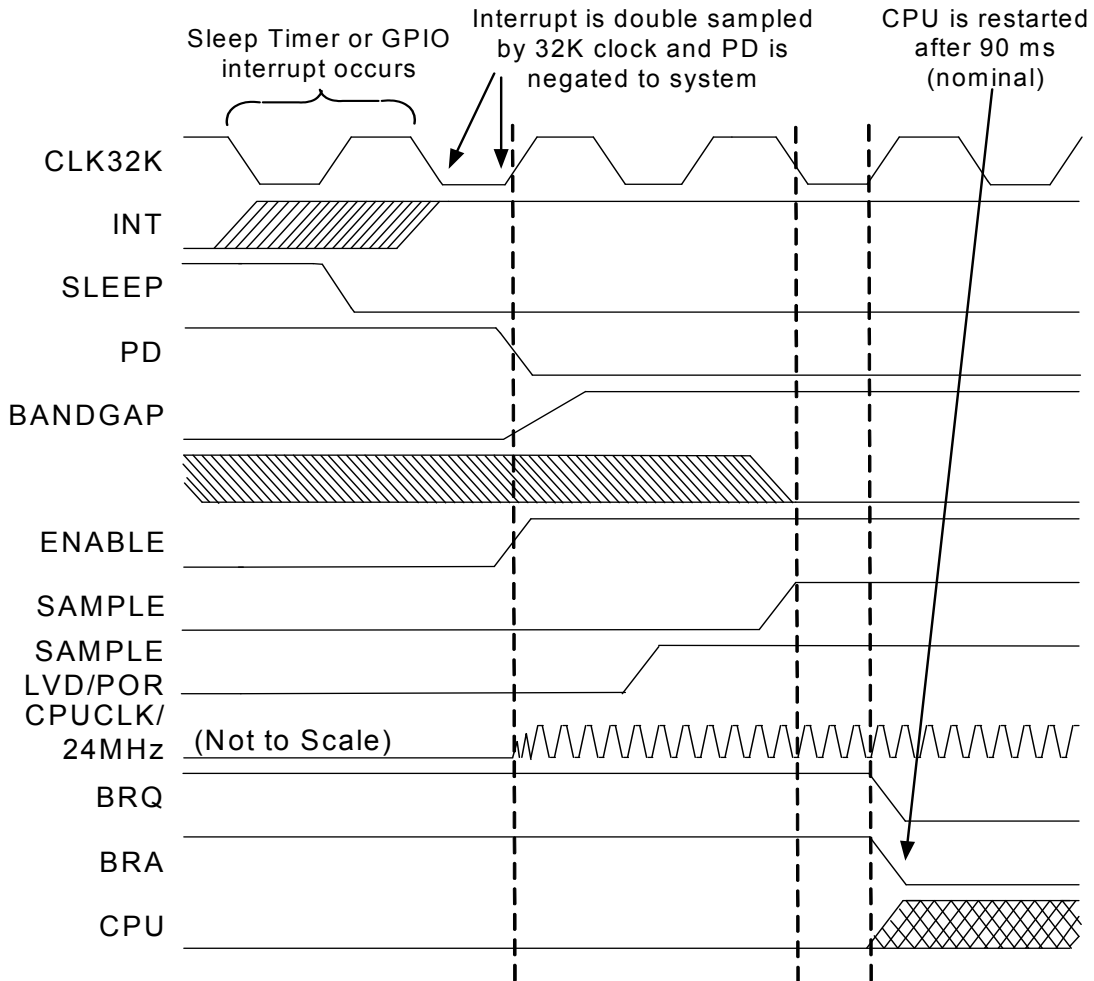

Low Voltage Detect Control

Table 42. Low Voltage Control Register (LVDCR) [0x1E3] [R/W]

Bit #	7	6	5	4	3	2	1	0
Field	Reserved		PORLEV[1:0]		Reserved	VM[2:0]		
Read/Write	–	–	R/W	R/W	–	R/W	R/W	R/W
Default	0	0	0	0	0	0	0	0

This register controls the configuration of the Power on Reset/Low voltage Detection circuit. This register can only be accessed in the second bank of I/O space. This requires setting the XIO bit in the CPU flags register.

Bits 7:6 Reserved

Bits 5:4 PORLEV[1:0]

This field controls the level below which the precision power on reset (PPOR) detector generates a reset

0 0 = 2.7 V Range (trip near 2.6 V)

0 1 = 3 V Range (trip near 2.9 V)

1 0 = Reserved

1 1 = PPOR does not generate a reset, but values read from the Voltage Monitor Comparators Register ([Table 43](#) on page 37) give the internal PPOR comparator state with trip point set to the 3 V range setting.

Bit 3 Reserved

Bits 2:0 VM[2:0]

This field controls the level below which the low voltage-detect trips—possibly generating an interrupt and the level at which the Flash is enabled for operation.

VM[2:0]	LVD Trip Point Typ. (V)
000	2.7
001	2.92
010	3.02
011	3.13
100	
101	
110	
111	

POR Compare State

Table 43. Voltage Monitor Comparators Register (VLTCMP) [0x1E4] [R]

Bit #	7	6	5	4	3	2	1	0
Field	Reserved						LVD	PPOR
Read/Write	–	–	–	–	–	–	R	R
Default	0	0	0	0	0	0	0	0

This read-only register allows reading the current state of the Low voltage Detection and Precision-Power-On-Reset comparators:

Bits 7:2 Reserved

Bit 1 LVD

This bit is set to indicate that the low voltage detect comparator has tripped, indicating that the supply voltage has gone below the trip point set by VM[2:0] (see Table 42 on page 36).

0 = No low voltage detect event

1 = A low voltage detect has tripped

Bit 0 PPOR

This bit is set to indicate that the precision-power-on-reset comparator has tripped, indicating that the supply voltage is below the trip point set by PORLEV[1:0]:

0 = No precision-power-on-reset event

1 = A precision-power-on-reset event has tripped

Note This register can only be accessed in the second bank of I/O space. This requires setting the XIO bit in the CPU flags register

ECO Trim Register

Table 44. ECO (ECO_TR) [0x1EB] [R/W]

Bit #	7	6	5	4	3	2	1	0
Field	Sleep Duty Cycle [1:0]		Reserved					
Read/Write	R/W	R/W	–	–	–	–	–	–
Default	0	0	0	0	0	0	0	0

This register controls the ratios (in numbers of 32 kHz clock periods) of ‘on’ time versus ‘off’ time for LVD and POR detection circuit.

Bits 7:6 Sleep Duty Cycle [1:0]

0 0 = 1/128 periods of the Internal 32 kHz Low-speed Oscillator

0 1 = 1/512 periods of the Internal 32 kHz Low-speed Oscillator

1 0 = 1/32 periods of the Internal 32 kHz Low-speed Oscillator

1 1 = 1/8 periods of the Internal 32 kHz Low speed Oscillator

Note This register can only be accessed in the second bank of I/O space. This requires setting the XIO bit in the CPU flags register

General Purpose I/O Ports

The general purpose I/O ports are discussed in the following sections.

Port Data Registers

Table 45. P0 Data Register (P0DATA)[0x00] [R/W]

Bit #	7	6	5	4	3	2	1	0
Field	P0.7	Reserved		P0.4/INT2	P0.3/INT1	Reserved	P0.1	Reserved
Read/Write	R/W	–		R/W	R/W	–	R/W	–
Default	0	–	–	0	0	0	0	–

This register contains the data for Port 0. Writing to this register sets the bit values to be output on output enabled pins. Reading from this register returns the current state of the Port 0 pins.

Bit 7 P0.7 Data

Bits 6:5 Reserved

Bits 4:3 P0.4–P0.3Data/INT2–INT1

In addition to their use as the P0.4–P0.3 GPIOs, these pins can also be used for the alternative functions as the Interrupt pins (INT1–INT2). To configure the P0.4–P0.3 pins, refer to the P0.3/INT1–P0.4/INT2 Configuration Register (Table 49 on page 40).

Bit 2 Reserved

Bit 1 P0.1 Data

Bit 0 Reserved

Table 46. P1 Data Register (P1DATA) [0x01] [R/W]

Bit #	7	6	5	4	3	2	1	0
Field	P1.7	P1.6	P1.5/SMOSI	P1.4/SCLK	P1.3/SSEL	P1.2	P1.1	P1.0
Read/Write	R/W	R/W	R/W	R/W	R/W	R/W	R/W	R/W
Default	0	0	0	0	0	0	0	–

This register contains the data for Port 1. Writing to this register sets the bit values to be output on output enabled pins. Reading from this register returns the current state of the Port 1 pins.

Bits 7 P1.7

Bits 6 P1.6 or alternate function of SMOSI in a 4-wire SPI

Bits 5:3 P1.5–P1.3 Data/3-wire SPI Pins (SMISO/SMOSI, SCLK, SSEL)

In addition to their use as the P1.6–P1.3 GPIOs, these pins can also be used for the alternative function as the SPI interface pins. To configure the P1.6–P1.3 pins, refer to the P1.3–P1.6 Configuration Register (Table 54 on page 42)

Bits 2:1 P1.2–P1.1

Bit 0 P1.0

Table 47. P2 Data Register (P2DATA) [0x02] [R/W]

Bit #	7	6	5	4	3	2	1	0
Field	Reserved						P2.1–P2.0	
Read/Write	–						R/W	R/W
Default	–						0	0

This register contains the data for Port 2. Writing to this register sets the bit values to be output on output enabled pins. Reading from this register returns the current state of the Port 2 pins.

Bits 7:2 P2 Data [7:2]

Bits 1:0 P2 Data [1:0]

GPIO Port Configuration

All the GPIO configuration registers have common configuration controls. The following are the bit definitions of the GPIO configuration registers. By default all GPIOs are configured as inputs. To prevent the inputs from floating, the pull up resistors are enabled. Firmware needs to configure each of the GPIOs before use.

Int Enable

When set, the Int Enable bit allows the GPIO to generate interrupts. Interrupt generate can occur regardless of whether the pin is configured for input or output. All interrupts are edge sensitive, however for any interrupt that is shared by multiple sources (that is, Ports 2, 3, and 4) all inputs must be deasserted before a new interrupt can occur.

When clear, the corresponding interrupt is disabled on the pin.

It is possible to configure GPIOs as outputs, enable the interrupt on the pin and then to generate the interrupt by driving the appropriate pin state. This is useful in test and may have value in applications.

Int Act Low

When clear, the corresponding interrupt is active HIGH. When set, the interrupt is active LOW. For P0.3–P0.4 Int act Low clear causes interrupts to be active on the rising edge. Int act Low set causes interrupts to be active on the falling edge.

TTL Thresh

When set, the input has TTL threshold. When clear, the input has standard CMOS threshold.

Important Note The GPIOs default to CMOS threshold. User’s firmware needs to configure the threshold to TTL mode if necessary.

High Sink

When set, the output can sink up to 50 mA.

When clear, the output can sink up to 8 mA.

Open Drain

When set, the output on the pin is determined by the Port Data Register. If the corresponding bit in the Port Data Register is set, the pin is in high impedance state. If the corresponding bit in the Port Data Register is clear, the pin is driven LOW.

When clear, the output is driven LOW or HIGH.

Pull up Enable

When set the pin has a 7K pull up to V_{DD}.

When clear, the pull up is disabled.

Output Enable

When set, the output driver of the pin is enabled.

When clear, the output driver of the pin is disabled.

For pins with shared functions there are some special cases.

P0.0 (CLKIN) and P0.1 (CLKOUT) can not be output enabled when the crystal oscillator is enabled. Output enables for these pins are overridden by XOSC Enable.

P1.3 (SSEL), P1.4 (SCLK), P1.5 (SMOSI) and P1.6 (SMISO) can be used for their dedicated functions or for GPIO. To enable the pin for GPIO use, clear the corresponding SPI Use bit or the Output Enable has no effect.

SPI Use

The P1.3 (SSEL), P1.4 (SCLK), P1.5 (SMOSI) and P1.6 (SMISO) pins can be used for their dedicated functions or for GPIO. To enable the pin for GPIO, clear the corresponding SPI Use bit. The SPI function controls the output enable for its dedicated function pins when their GPIO enable bit is clear.

Table 48. P0.1 Configuration (P01CR) [0x06] R/W

Bit #	7	6	5	4	3	2	1	0
Field	Reserved	Int Enable	Int Act Low	TTL Thresh	High Sink	Open Drain	Pull up Enable	Output Enable
Read/Write	R/W	R/W	R/W	R/W	R/W	R/W	R/W	R/W
Default	0	0	0	0	0	0	0	0

This register is used to configure P0.1. In the CYRF69103, only 8 mA sink drive capability is available on this pin regardless of the setting of the High Sink bit.

If this pin is used as a general purpose output it draws current. This pin must be configured as an input to reduce current draw.

- Bit 7 Reserved
- Bit 6 see [Int Enable](#)
- Bit 5 see [Int Act Low](#)
- Bit 4 see [TTL Thresh](#)
- Bit 3 see [High Sink](#)
- Bit 2 see [Open Drain](#)
- Bit 1 see [Pull up Enable](#)
- Bit 0 see [Output Enable](#)

Table 49. P0.3–P0.4 Configuration (P03CR–P04CR) [0x08–0x09] [R/W]

Bit #	7	6	5	4	3	2	1	0
Field	Reserved		Int Act Low	TTL Thresh	Reserved	Open Drain	Pull up Enable	Output Enable
Read/Write	–	–	R/W	R/W	–	R/W	R/W	R/W
Default	0	0	0	0	0	0	0	0

These registers control the operation of pins P0.3–P0.4 respectively. These pins are shared between the P0.3–P0.4 GPIOs and the INT1–INT2. The INT1–INT2 interrupts are different than all the other GPIO interrupts. These pins are connected directly to the interrupt controller to provide three edge-sensitive interrupts with independent interrupt vectors. These interrupts occur on a rising edge when Int act Low is clear and on a falling edge when Int act Low is set. These pins are enabled as interrupt sources in the interrupt controller registers (Table 75 on page 55 and Table 73 on page 54).

To use these pins as interrupt inputs, configure them as inputs by clearing the corresponding Output Enable. If the INT1–INT2 pins are configured as outputs with interrupts enabled, firmware can generate an interrupt by writing the appropriate value to the P0.3, and P0.4 data bits in the P0 Data Register.

Regardless of whether the pins are used as Interrupt or GPIO pins the Int Enable, Int act Low, TTL Threshold, Open Drain, and Pull up Enable bits control the behavior of the pin.

The P0.3/INT1–P0.4/INT2 pins are individually configured with the P03CR (0x08), and P04CR (0x09) respectively.

Note Changing the state of the Int Act Low bit can cause an unintentional interrupt to be generated. When configuring these interrupt sources, it is best to follow the following procedure:

1. Disable interrupt source
2. Configure interrupt source
3. Clear any pending interrupts from the source
4. Enable interrupt source

Table 50. P0.7 Configuration (P07CR) [0x0C] [R/W]

Bit #	7	6	5	4	3	2	1	0
Field	Reserved	Int Enable	Int Act Low	TTL Thresh	Reserved	Open Drain	Pull up Enable	Output Enable
Read/Write	–	R/W	R/W	R/W	–	R/W	R/W	R/W
Default	0	0	0	0	0	0	0	0

This register controls the operation of pin P0.7.

- Bit 7 Reserved
- Bit 6 see [Int Enable](#)
- Bit 5 see [Int Act Low](#)
- Bit 4 see [TTL Thresh](#)
- Bit 3 Reserved
- Bit 2 see [Open Drain](#)
- Bit 1 see [Pull up Enable](#)
- Bit 0 see [Output Enable](#)

Table 51. P1.0 Configuration (P10CR) [0x0D] [R/W]

Bit #	7	6	5	4	3	2	1	0
Field	Reserved	Int Enable	Int Act Low	Reserved	Reserved	Reserved	5K pullup Enable	Output enable
Read/Write	R/W	R/W	R/W	-	-	-	R/W	R/W
Default	0	0	0	0	0	0	0	0

This register controls the operation of the P1.0 pin.

Note The P1.0 is an open drain only output. It can actively drive a signal low, but cannot actively drive a signal high.

Bit 0 This bit enables the output on P1.0. This bit must be cleared in sleep mode.

- Bit 7** Reserved
- Bit 6** see [Int Enable](#)
- Bit 5** see [Int Act Low](#)
- Bit 4** Reserved
- Bit 3** Reserved
- Bit 2** Reserved
- Bit 1** 0 = disables the 5K ohm pull up resistors
1 = enables 5K ohm pull up resistors for both P1.0 and P1.1 (this is not compatible with USB)

Table 52. P1.1 Configuration (P11CR) [0x0E] [R/W]

Bit #	7	6	5	4	3	2	1	0
Field	Reserved	Int Enable	Int Act Low	Reserved		Open Drain	Reserved	Output Enable
Read/Write	-	R/W	R/W	-	-	R/W	-	R/W
Default	0	0	0	0	0	0	0	0

This register controls the operation of the P1.1 pin.

The pull up resistor on this pin is enabled by the P10CR Register.

Note There is no 2 mA sourcing capability on this pin. The pin can only sink 5 mA at V_{OL3} section.

- Bit 7** Reserved
- Bit 6** see [Int Enable](#)
- Bit 5** see [Int Act Low](#)
- Bit 4** Reserved
- Bit 3** Reserved
- Bit 2** see [Open Drain](#)
- Bit 1** Reserved
- Bit 0** see [Output Enable](#)

Table 53. P1.2 Configuration (P12CR) [0x0F] [R/W]

Bit #	7	6	5	4	3	2	1	0
Field	CLK Output	Int Enable	Int Act Low	TTL Threshold	Reserved	Open Drain	Pull up Enable	Output Enable
Read/Write	R/W	R/W	R/W	R/W	–	R/W	R/W	R/W
Default	0	0	0	0	0	0	0	0

This register controls the operation of the P1.2.

- Bit 7** CLK Output
0 = The internally selected clock is not sent out onto P1.2 pin.
1 = When CLK Output is set, the internally selected clock is sent out onto P1.2 pin.
- Bit 6** see [Int Enable](#)
- Bit 5** see [Int Act Low](#)
- Bit 4** Reserved
- Bit 3** see [High Sink](#)
- Bit 2** see [Open Drain](#)
- Bit 1** see [Pull up Enable](#)
- Bit 0** see [Output Enable](#)

Table 54. P1.3 Configuration (P13CR) [0x10] [R/W]

Bit #	7	6	5	4	3	2	1	0
Field	Reserved	Int Enable	Int Act Low	Reserved	High Sink	Open Drain	Pull up Enable	Output Enable
Read/Write	–	R/W	R/W	–	R/W	R/W	R/W	R/W
Default	0	0	0	0	0	0	0	0

This register controls the operation of the P1.3 pin.

The P1.3 GPIO's threshold is always set to TTL.

When the SPI hardware is enabled, the output enable and output state of the pin is controlled by the SPI circuitry. When the SPI hardware is disabled, the pin is controlled by the Output Enable bit and the corresponding bit in the P1 data register.

Regardless of whether the pin is used as an SPI or GPIO pin the Int Enable, Int act Low, High Sink, Open Drain, and Pull up Enable control the behavior of the pin.

50 mA sink drive capability is available.

- Bit 7** Reserved
- Bit 6** see [Int Enable](#)
- Bit 5** see [Int Act Low](#)
- Bit 4** Reserved
- Bit 3** see [High Sink](#)
- Bit 2** see [Open Drain](#)
- Bit 1** see [Pull up Enable](#)
- Bit 0** see [Output Enable](#)

Table 55. P1.4–P1.6 Configuration (P14CR–P16CR) [0x11–0x13] [R/W]

Bit #	7	6	5	4	3	2	1	0
Field	SPI Use	Int Enable	Int Act Low	Reserved	High Sink	Open Drain	Pull up Enable	Output Enable
Read/Write	R/W	R/W	R/W	–	R/W	R/W	R/W	R/W
Default	0	0	0	0	0	0	0	0

These registers control the operation of pins P1.4–P1.6, respectively.

The P1.4–P1.6 GPIO's threshold is always set to TTL.

When the SPI hardware is enabled, pins that are configured as SPI Use have their output enable and output state controlled by the SPI circuitry. When the SPI hardware is disabled or a pin has its SPI Use bit clear, the pin is controlled by the Output Enable bit and the corresponding bit in the P1 data register.

Regardless of whether any pin is used as an SPI or GPIO pin the Int Enable, Int act Low, High Sink, Open Drain, and Pull up Enable control the behavior of the pin.

- Bit 7** SPI Use
0 = Disable the SPI alternate function. The pin is used as a GPIO
1 = Enable the SPI function. The SPI circuitry controls the output of the pin
- Bit 6** see [Int Enable](#)
- Bit 5** see [Int Act Low](#)
- Bit 4** Reserved
- Bit 3** see [High Sink](#)
- Bit 2** see [Open Drain](#)
- Bit 1** see [Pull up Enable](#)
- Bit 0** see [Output Enable](#)

Note For Comm Modes 01 or 10 (SPI Master or SPI Slave, see [Table 59](#) on page 46)

When configured for SPI (SPI Use = 1 and Comm Modes [1:0] = SPI Master or SPI Slave mode), the input/output direction of pins P1.3, P1.5, and P1.6 is set automatically by the SPI logic. However, pin P1.4's input/output direction is NOT automatically set; it must be explicitly set by firmware. For SPI Master mode, pin P1.4 must be configured as an output; for SPI Slave mode, pin P1.4 must be configured as an input.

Table 56. P1.7 Configuration (P17CR) [0x14] [R/W]

Bit #	7	6	5	4	3	2	1	0
Field	Reserved	Int Enable	Int Act Low	Reserved	High Sink	Open Drain	Pull up Enable	Output Enable
Read/Write	–	R/W	R/W	–	R/W	R/W	R/W	R/W
Default	0	0	0	0	0	0	0	0

This register controls the operation of pin P1.7.

50 mA sink drive capability is available. The P1.7 GPIO's threshold is always set to TTL.

- Bit 7** Reserved
- Bit 6** see [Int Enable](#)
- Bit 5** see [Int Act Low](#)
- Bit 4** Reserved
- Bit 3** see [High Sink](#)
- Bit 2** see [Open Drain](#)
- Bit 1** see [Pull up Enable](#)
- Bit 0** see [Output Enable](#)

Table 57. P2 Configuration (P2CR) [0x15] [R/W]

Bit #	7	6	5	4	3	2	1	0
Field	Reserved	Int Enable	Int Act Low	TTL Thresh	High Sink	Open Drain	Pull up Enable	Output Enable
Read/Write	–	R/W	R/W	R/W	R/W	R/W	R/W	R/W
Default	0	0	0	0	0	0	0	0

This register controls the operation of pins P2.0–P2.1.

- Bit 7** Reserved
- Bit 6** see [Int Enable](#)
- Bit 5** see [Int Act Low](#)
- Bit 4** see [TTL Thresh](#)
- Bit 3** see [High Sink](#)
- Bit 2** see [Open Drain](#)
- Bit 1** see [Pull up Enable](#)
- Bit 0** see [Output Enable](#)

GPIO Configurations for Low Power Mode

To ensure low power mode, unbonded GPIO pins in CYRF69103 must be placed in a non-floating state. The following assembly code snippet shows how this is achieved. This snippet can be added as a part of the initialization routine.

```

//Code Snippet for addressing unbonded GPIOs

mov A, 01h
mov reg[1Fh],A
mov A, 01h
mov reg[16h],A // Port3 Configuration register - Enable output
mov A, 00h
mov reg[03h],A // Asserting P3.0 to P3.7 outputs to '0'
//Port 2 configurations
mov A,01h
mov reg[15h],A //Port 2 Configuration register -Enable output
mov A,00h
mov reg[02h],A //Asserting P2.0 to P2.7 outputs to '0'
mov A, 01h
mov reg[05h],A // Port0.0 Configuration register - Enable output
mov reg[07h],A // Port0.2 Configuration register - Enable output
mov reg[0Ah],A // Port0.5 Configuration register - Enable output
mov reg[0Bh],A // Port0.6 Configuration register - Enable output
mov A,reg[00h]
mov A,00h
and A,9Ah
mov reg[00h], A // Asserting outputs '0' to pins in port 1
// NOTE: The code fragment in italics is to be used only if your application configures P2.0 and P2.1 as push-pull outputs.

```

When writing to port 0, to access GPIOs P0.1,3,4,7, mask bits 0,2,5,6. Failing to do so voids the low power.

Serial Peripheral Interface (SPI)

The SPI Master/Slave Interface core logic runs on the SPI clock domain. The SPI clock is a divider off of the CPUCLK when in Master Mode. SPI is a four-pin serial interface comprised of a clock, an enable, and two data pins.

Figure 14. SPI Block Diagram

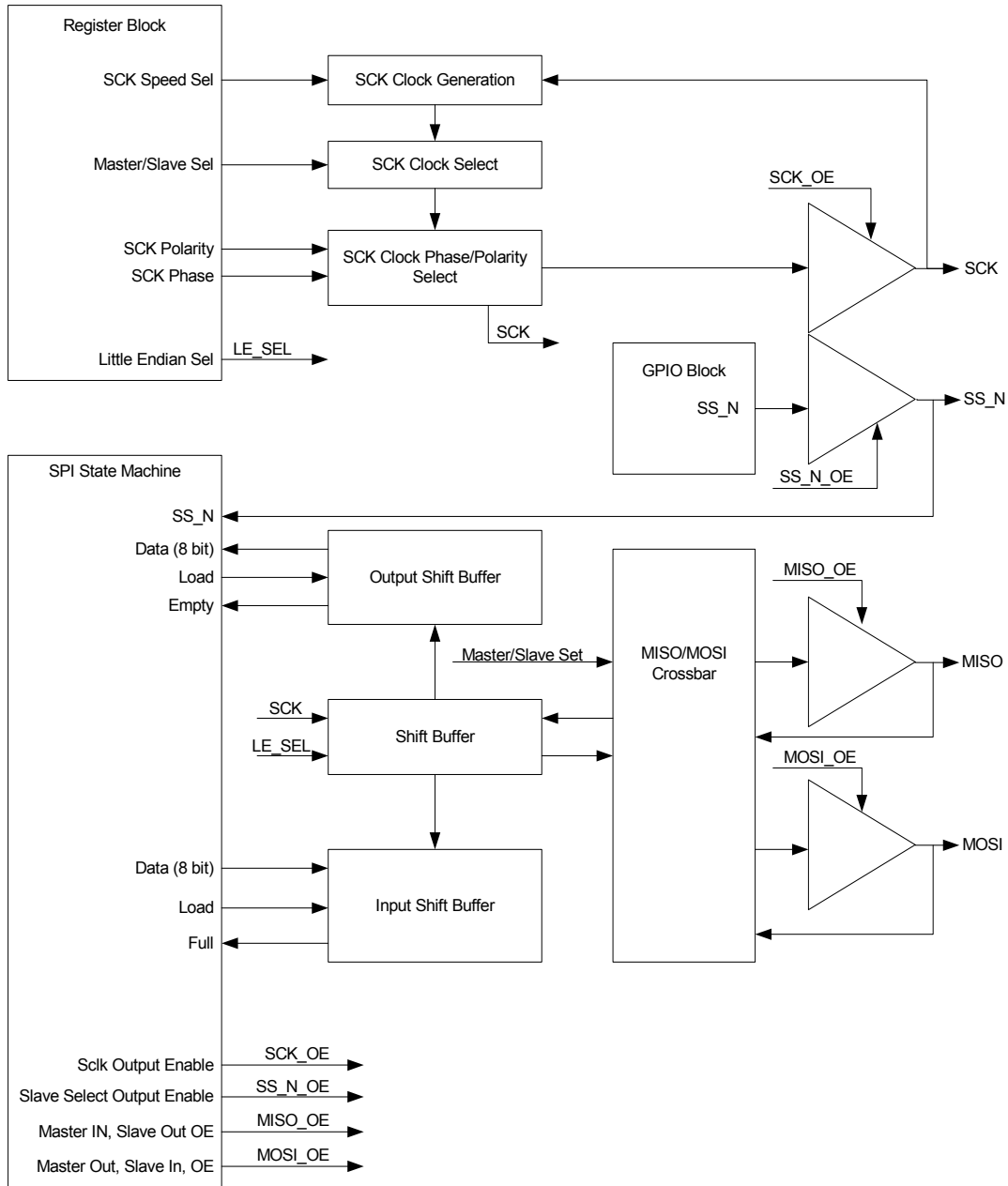

SPI Data Register

Table 58. SPI Data Register (SPIDATA) [0x3C] [R/W]

Bit #	7	6	5	4	3	2	1	0
Field	SPIData[7:0]							
Read/Write	R/W	R/W	R/W	R/W	R/W	R/W	R/W	R/W
Default	0	0	0	0	0	0	0	0

When read, this register returns the contents of the receive buffer. When written, it loads the transmit holding register.

Bits 7:0 SPI Data [7:0]

When an interrupt occurs to indicate to firmware that a byte of receive data is available, or the transmitter holding register is empty, firmware has 7 SPI clocks to manage the buffers – to empty the receiver buffer, or to refill the transmit holding register. Failure to meet this timing requirement results in incorrect data transfer.

SPI Configure Register

Table 59. SPI Configure Register (SPICR) [0x3D] [R/W]

Bit #	7	6	5	4	3	2	1	0
Field	Swap	LSB First	Comm Mode		CPOL	CPHA	SCLK Select	
Read/Write	R/W	R/W	R/W	R/W	R/W	R/W	R/W	R/W
Default	0	0	0	0	0	0	0	0

Bit 7 Swap
 0 = Swap function disabled.
 1 = The SPI block swaps its use of SMOSI and SMISO. Among other things, this can be useful in implementing single wire SPI-like communications.

Bit 6 LSB First
 0 = The SPI transmits and receives the MSB (Most Significant Bit) first.
 1 = The SPI transmits and receives the LSB (Least Significant Bit) first.

Bits 5:4 Comm Mode [1:0]
 0 0: All SPI communication disabled.
 0 1: SPI master mode
 1 0: SPI slave mode
 1 1: Reserved

Bit 3 CPOL
 This bit controls the SPI clock (SCLK) idle polarity.
 0 = SCLK idles low
 1 = SCLK idles high

Bit 2 CPHA
 The Clock Phase bit controls the phase of the clock on which data is sampled. [Table 60](#) on page 47 shows the timing for the various combinations of LSB First, CPOL, and CPHA.

Bits 1:0 SCLK Select
 This field selects the speed of the master SCLK. When in master mode, SCLK is generated by dividing the base CPUCLK.

Important Note for Comm Modes 01b or 10b (SPI Master or SPI Slave):

When configured for SPI, (SPI Use = 1 – [Table 55](#) on page 43), the input/output direction of pins P1.3, P1.5, and P1.6 is set automatically by the SPI logic. However, pin P1.4’s input/output direction is NOT automatically set; it must be explicitly set by firmware. For SPI Master mode, pin P1.4 must be configured as an output; for SPI Slave mode, pin P1.4 must be configured as an input.

Table 60. SPI Mode Timing vs. LSB First, CPOL and CPHA

LSB First	CPHA	CPOL	Diagram
0	0	0	
0	0	1	
0	1	0	
0	1	1	
1	0	0	
1	0	1	
1	1	0	
1	1	1	

Table 61. SPI SCLK Frequency

SCLK Select	CPUCLK Divisor	SCLK Frequency when CPUCLK = 12 MHz
00	6	2 MHz
01	12	1 MHz
10	48	250 kHz
11	96	125 kHz

SPI Interface Pins

The SPI interface between the radio function and MCU function uses pins P1.3–P1.5 and optionally P1.6. These pins are configured using the P1.3 and P1.4–P1.6 Configuration.

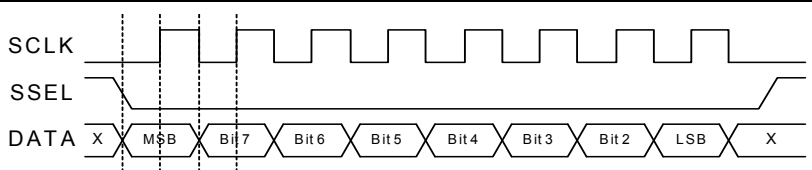
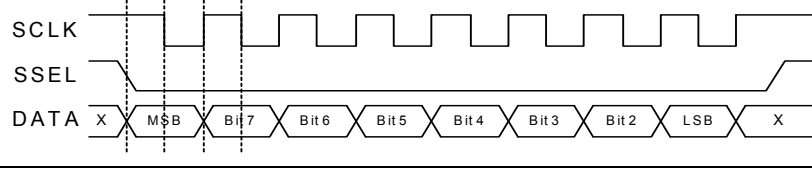
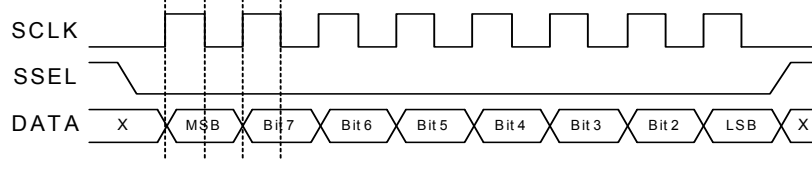
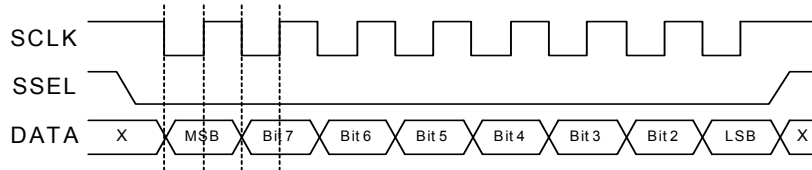
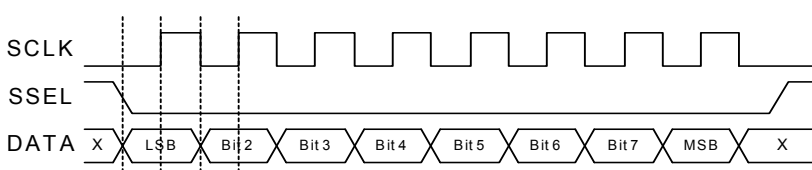
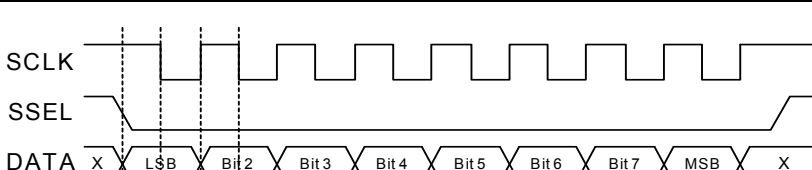
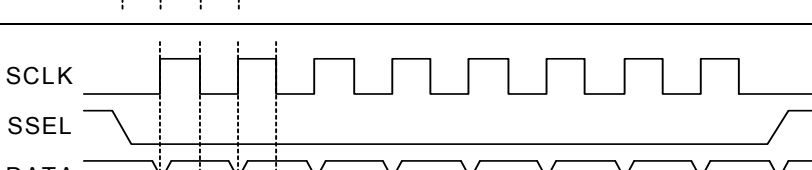
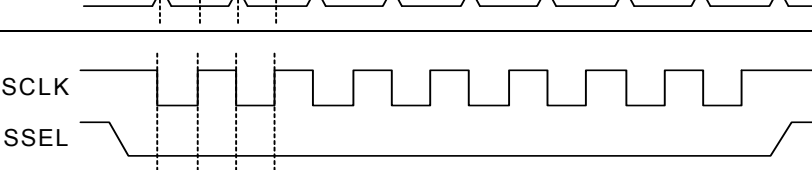
Timer Registers

All timer functions of the CYRF69103 are provided by a single timer block. The timer block is asynchronous from the CPU clock. The 16-bit free running counter is used as the time-base for timer captures and can also be used as a general time-base by software.

Registers

Free Running Counter

The 16-bit free running counter is clocked by a 4 or 6 MHz source. It can be read in software for use as a general purpose time base. When the low order byte is read, the high order byte is registered. Reading the high order byte reads this register allowing the CPU to read the 16-bit value atomically (loads all bits at one time). The free running timer generates an interrupt at 1024 μ s rate. It can also generate an interrupt when the free running counter overflow occurs—every 16.384 ms. This allows extending the length of the timer in software.

Figure 15. 16-bit Free Running Counter Block Diagram

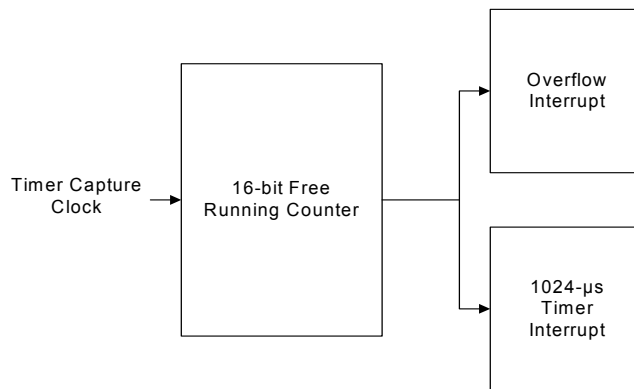

Table 62. Free Running Timer Low Order Byte (FRTMRL) [0x20] [R/W]

Bit #	7	6	5	4	3	2	1	0
Field	Free Running Timer [7:0]							
Read/Write	R/W	R/W	R/W	R/W	R/W	R/W	R/W	R/W
Default	0	0	0	0	0	0	0	0

Bits 7:0 Free running Timer [7:0]

This register holds the low order byte of the 16-bit free running timer. Reading this register causes the high order byte to be moved into a holding register allowing an automatic read of all 16 bits simultaneously.

For reads, the actual read occurs in the cycle when the low order is read. For writes the actual time the write occurs is the cycle when the high order is written.

When reading the free running timer, the low order byte must be read first and the high order second. When writing, the low order byte must be written first then the high order byte.

Table 63. Free Running Timer High-Order Byte (FRTMRH) [0x21] [R/W]

Bit #	7	6	5	4	3	2	1	0
Field	Free Running Timer [15:8]							
Read/Write	R/W	R/W	R/W	R/W	R/W	R/W	R/W	R/W
Default	0	0	0	0	0	0	0	0

Bits 7:0 Free Running Timer [15:8]

When reading the free running timer, the low order byte must be read first and the high order second. When writing, the low order byte must be written first then the high order byte.

Table 64. Programmable Interval Timer Low (PITML) [0x26] [R]

Bit #	7	6	5	4	3	2	1	0
Field	Prog Interval Timer [7:0]							
Read/Write	R	R	R	R	R	R	R	R
Default	0	0	0	0	0	0	0	0

Bits 7:0 Prog Interval Timer [7:0]

This register holds the low order byte of the 12-bit programmable interval timer. Reading this register causes the high order byte to be moved into a holding register allowing an automatic read of all 12 bits simultaneously.

Table 65. Programmable Interval Timer High (PITMRH) [0x27] [R]

Bit #	7	6	5	4	3	2	1	0
Field	Reserved				Prog Interval Timer [11:8]			
Read/Write	--	--	--	--	R	R	R	R
Default	0	0	0	0	0	0	0	0

Bits 7:4 Reserved

Bits 3:0 Prog Internal Timer [11:8]

This register holds the high order nibble of the 12-bit programmable interval timer. Reading this register returns the high order nibble of the 12-bit timer at the instant that the low order byte was last read.

Table 66. Programmable Interval Reload Low (PIRL) [0x28] [R/W]

Bit #	7	6	5	4	3	2	1	0
Field	Prog Interval [7:0]							
Read/Write	R/W	R/W	R/W	R/W	R/W	R/W	R/W	R/W
Default	0	0	0	0	0	0	0	0

Bits 7:0 Prog Interval [7:0]

This register holds the lower 8 bits of the timer. While writing into the 12-bit reload register, write lower byte first then the higher nibble.

Table 67. Programmable Interval Reload High (PIRH) [0x29] [R/W]

Bit #	7	6	5	4	3	2	1	0
Field	Reserved				Prog Interval[11:8]			
Read/Write	--	--	--	--	R/W	R/W	R/W	R/W
Default	0	0	0	0	0	0	0	0

Bits [7:4] Reserved

Bits 3:0 Prog Interval [11:8]

This register holds the higher 4 bits of the timer. While writing into the 12-bit reload register, write lower byte first then the higher nibble.

Figure 16. 16-Bit Free Running Counter Loading Timing Diagram

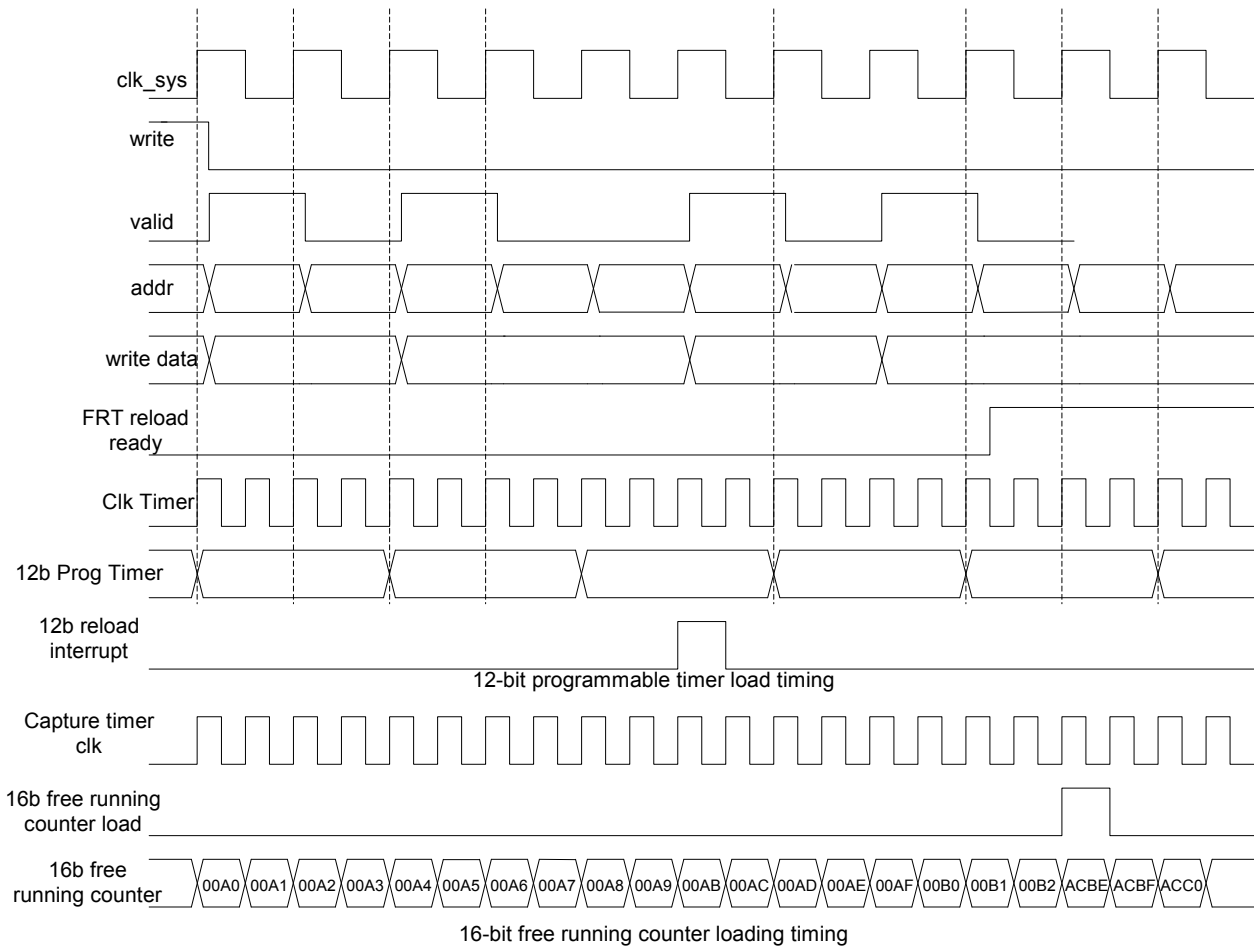
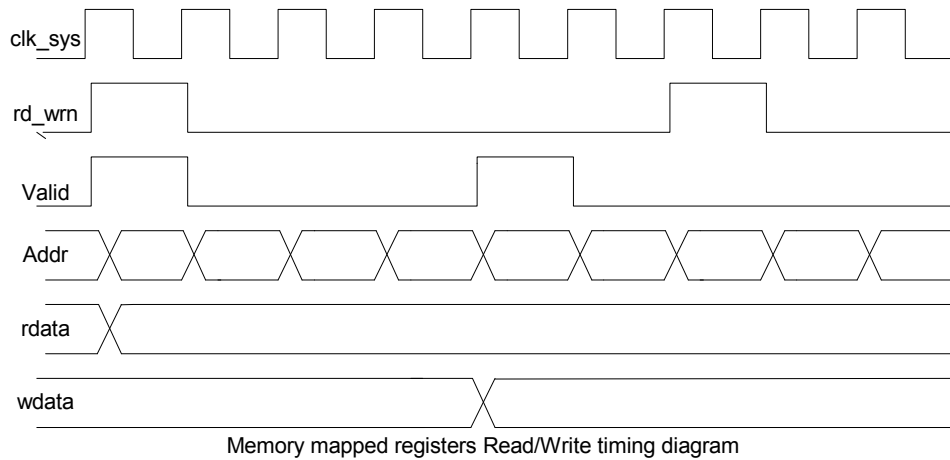

Figure 17. Memory Mapped Registers Read/Write Timing Diagram



Interrupt Controller

The interrupt controller and its associated registers allow the user’s code to respond to an interrupt from almost every functional block in the CYRF69103 devices. The registers associated with the interrupt controller allow interrupts to be disabled either globally or individually. The registers also provide a mechanism by which a user may clear all pending and posted interrupts, or clear individual posted or pending interrupts.

The following table lists all interrupts and the priorities that are available in the CYRF69103.

Table 68. Interrupt Priorities, Address, Name

Interrupt Priority	Interrupt Address	Name
0	0000h	Reset
1	0004h	POR/LVD
2	0008h	Reserved
3	000Ch	SPI Transmitter Empty
4	0010h	SPI Receiver Full
5	0014h	GPIO Port 0
6	0018h	GPIO Port 1
7	001Ch	INT1
8	0020h	Reserved
9	0024h	Reserved
10	0028h	Reserved
11	002Ch	Reserved
12	0030h	Reserved
13	0034h	1 ms Interval timer
14	0038h	Programmable Interval Timer
15	003Ch	Reserved

Table 68. Interrupt Priorities, Address, Name (continued)

Interrupt Priority	Interrupt Address	Name
16	0040h	Reserved
17	0044h	16-bit Free Running Timer Wrap
18	0048h	INT2
19	004Ch	Reserved
20	0050h	GPIO Port 2
21	0054h	Reserved
22	0058h	Reserved
23	005Ch	Reserved
24	0060h	Reserved
25	0064h	Sleep Timer

Architectural Description

An interrupt is posted when its interrupt conditions occur. This results in the flip-flop in Figure 18 on page 52 clocking in a ‘1’. The interrupt remains posted until the interrupt is taken or until it is cleared by writing to the appropriate INT_CLRx register.

A posted interrupt is not pending unless it is enabled by setting its interrupt mask bit (in the appropriate INT_MSKx register). All pending interrupts are processed by the Priority Encoder to determine the highest priority interrupt which is taken by the M8C if the Global Interrupt Enable bit is set in the CPU_F register.

Disabling an interrupt by clearing its interrupt mask bit (in the INT_MSKx register) does not clear a posted interrupt, nor does it prevent an interrupt from being posted. It simply prevents a posted interrupt from becoming pending.

Nested interrupts can be accomplished by reenabling interrupts inside an interrupt service routine. To do this, set the IE bit in the Flag Register.

A block diagram of the CYRF69103 Interrupt Controller is shown in Figure 18 on page 52.

Figure 18. Interrupt Controller Block Diagram

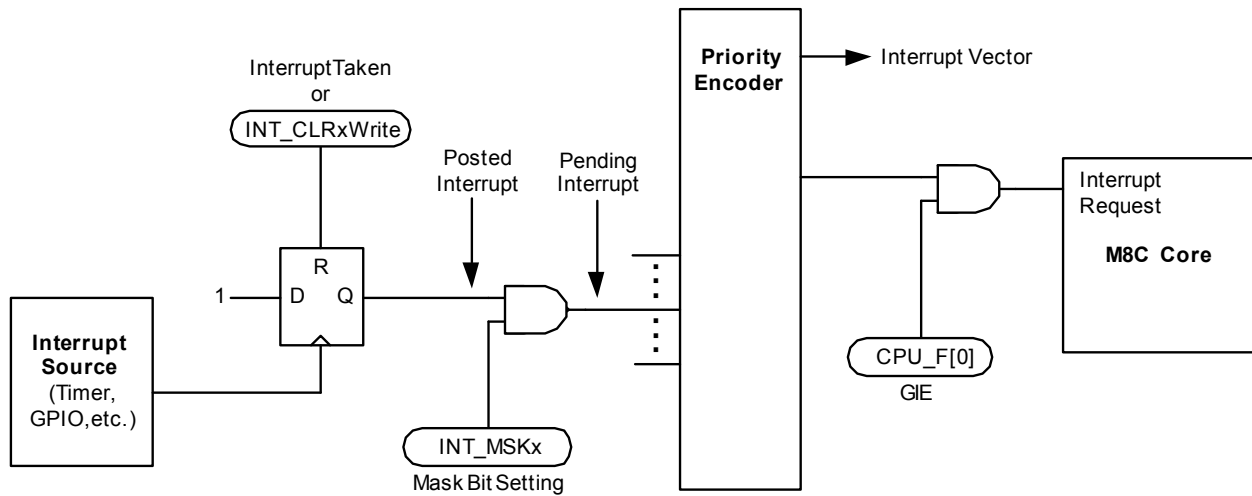

Interrupt Processing

The sequence of events that occur during interrupt processing is as follows:

1. An interrupt becomes active, either because:
 - a. The interrupt condition occurs (for example, a timer expires).
 - b. A previously posted interrupt is enabled through an update of an interrupt mask register.
 - c. An interrupt is pending and GIE is set from 0 to 1 in the CPU Flag register.
2. The current executing instruction finishes.
3. The internal interrupt is dispatched, taking 13 cycles. During this time, the following actions occur:
 - a. The MSB and LSB of Program Counter and Flag registers (CPU_PC and CPU_F) are stored onto the program stack by an automatic CALL instruction (13 cycles) generated during the interrupt acknowledge process.
 - b. The PCH, PCL, and Flag register (CPU_F) are stored onto the program stack (in that order) by an automatic CALL instruction (13 cycles) generated during the interrupt acknowledge process.
 - c. The CPU_F register is then cleared. Because this clears the GIE bit to 0, additional interrupts are temporarily disabled.
 - d. The PCH (PC[15:8]) is cleared to zero.
 - e. The interrupt vector is read from the interrupt controller and its value placed into PCL (PC[7:0]). This sets the program counter to point to the appropriate address in the interrupt table (for example, 0004h for the POR/LVD interrupt).
4. Program execution vectors to the interrupt table. Typically, a LJMP instruction in the interrupt table sends execution to the user's Interrupt Service Routine (ISR) for this interrupt.
5. The ISR executes. Note that interrupts are disabled because GIE = 0. In the ISR, interrupts can be re-enabled if desired by setting GIE = 1 (care must be taken to avoid stack overflow).

6. The ISR ends with a RETI instruction which restores the Program Counter and Flag registers (CPU_PC and CPU_F). The restored Flag register re-enables interrupts because GIE = 1 again.
7. Execution resumes at the next instruction, after the one that occurred before the interrupt. However, if there are more pending interrupts, the subsequent interrupts are processed before the next normal program instruction.

Interrupt Latency

The time between the assertion of an enabled interrupt and the start of its ISR can be calculated from the following equation.

Latency = Time for current instruction to finish + Time for internal interrupt routine to execute + Time for LJMP instruction in interrupt table to execute.

For example, if the 5-cycle JMP instruction is executing when an interrupt becomes active, the total number of CPU clock cycles before the ISR begins is as follows:

$$(1 \text{ to } 5 \text{ cycles for JMP to finish}) + (13 \text{ cycles for interrupt routine}) + (7 \text{ cycles for LJMP}) = 21 \text{ to } 25 \text{ cycles.}$$

In the following example, at 12 MHz, 25 clock cycles take 2.08 μs.

Interrupt Registers

The Interrupt Registers are discussed in the following sections.

Interrupt Clear Register

The Interrupt Clear Registers (INT_CLRx) are used to enable the individual interrupt sources' ability to clear posted interrupts.

When an INT_CLRx register is read, any bits that are set indicates an interrupt has been posted for that hardware resource. Therefore, reading these registers gives the user the ability to determine all posted interrupts.

Table 69. Interrupt Clear 0 (INT_CLR0) [0xDA] [R/W]

Bit #	7	6	5	4	3	2	1	0
Field	GPIO Port 1	Sleep Timer	INT1	GPIO Port 0	SPI Receive	SPI Transmit	Reserved	POR/LVD
Read/Write	R/W	R/W	R/W	R/W	R/W	R/W	R/W	R/W
Default	0	0	0	0	0	0	0	0

When reading this register:

0 = There is no posted interrupt for the corresponding hardware.

1 = Posted interrupt for the corresponding hardware present.

Writing a '0' to the bits clears the posted interrupts for the corresponding hardware. Writing a '1' to the bits and to the ENSWINT (Bit 7 of the INT_MSK3 Register) posts the corresponding hardware interrupt.

The GPIO interrupts are edge-triggered.

Table 70. Interrupt Clear 1 (INT_CLR1) [0xDB] [R/W]

Bit #	7	6	5	4	3	2	1	0
Field	Reserved	Prog Interval Timer	1 ms Programmable Interrupt	Reserved				
Read/Write	–	R/W	R/W	–	–	–	–	–
Default	0	0	0	0	0	0	0	0

When reading this register:

0 = There is no posted interrupt for the corresponding hardware.

1 = Posted interrupt for the corresponding hardware present.

Writing a '0' to the bits clears the posted interrupts for the corresponding hardware. Writing a '1' to the bits AND to the ENSWINT.

Bit 7 Reserved

Table 71. Interrupt Clear 2 (INT_CLR2) [0xDC] [R/W]

Bit #	7	6	5	4	3	2	1	0
Field	Reserved	Reserved	Reserved	GPIO Port2	Reserved	INT2	16-bit Counter Wrap	Reserved
Read/Write	–	–	–	R/W	–	R/W	R/W	–
Default	0	0	0	0	0	0	0	0

When reading this register:

0 = There is no posted interrupt for the corresponding hardware

1 = Posted interrupt for the corresponding hardware present.

Writing a '0' to the bits clears the posted interrupts for the corresponding hardware. Writing a '1' to the bits AND to the ENSWINT (Bit 7 of the INT_MSK3 Register) posts the corresponding hardware interrupt.

Bits 7,6,5,3,0]Reserved

Interrupt Mask Registers

The Interrupt Mask Registers (INT_MSKx) are used to enable the individual interrupt sources' ability to create pending interrupts.

There are four Interrupt Mask Registers (INT_MSK0, INT_MSK1, INT_MSK2, and INT_MSK3) that may be referred to in general as INT_MSKx. If cleared, each bit in an INT_MSKx register prevents a posted interrupt from becoming a pending interrupt (input to the priority encoder). However, an interrupt can still post even if its mask bit is zero. All INT_MSKx bits are independent of all other INT_MSKx bits.

If an INT_MSKx bit is set, the interrupt source associated with that mask bit may generate an interrupt that becomes a pending interrupt.

The Enable Software Interrupt (ENSWINT) bit in INT_MSK3[7] determines the way an individual bit value written to an INT_CLRx register is interpreted. When is cleared, writing 1's to an INT_CLRx register has no effect. However, writing 0's to an INT_CLRx register, when ENSWINT is cleared causes the corresponding interrupt to clear. If the ENSWINT bit is set, any 0's written to the INT_CLRx registers are ignored. However, 1's written to an INT_CLRx register, while ENSWINT is set, cause an interrupt to post for the corresponding interrupt.

Software interrupts can aid in debugging interrupt service routines by eliminating the need to create system level interactions that are sometimes necessary to create a hardware-only interrupt.

Table 72. Interrupt Mask 3 (INT_MSK3) [0xDE] [R/W]

Bit #	7	6	5	4	3	2	1	0
Field	ENSWINT	Reserved						
Read/Write	R	–	–	–	–	–	–	–
Default	0	0	0	0	0	0	0	0

Bit 7 Enable Software Interrupt (ENSWINT)
 0 = Disable. Writing 0's to an INT_CLRx register, when ENSWINT is cleared, cause the corresponding interrupt to clear
 1 = Enable. Writing 1's to an INT_CLRx register, when ENSWINT is set, cause the corresponding interrupt to post

Bits 6:0 Reserved

Table 73. Interrupt Mask 2 (INT_MSK2) [0xDF] [R/W]

Bit #	7	6	5	4	3	2	1	0
Field	Reserved	Reserved	Reserved	GPIO Port 2 Int Enable	Reserved	INT2 Int Enable	16-bit Counter Wrap Int Enable	Reserved
Read/Write	–	–	–	R/W	–	R/W	R/W	–
Default	0	0	0	0	0	0	0	0

Bit 7: Reserved
Bit 6: Reserved
Bit 5: Reserved
Bit 4: GPIO Port 2 Interrupt Enable
 0 = Mask GPIO Port 2 interrupt
 1 = Unmask GPIO Port 2 interrupt
Bit 3: Reserved
Bit 2: INT2 Interrupt Enable
 0 = Mask INT2 interrupt
 1 = Unmask INT2 interrupt
Bit 1: 16-bit Counter Wrap Interrupt Enable
 0 = Mask 16-bit Counter Wrap interrupt
 1 = Unmask 16-bit Counter Wrap interrupt
Bit 0: Reserved
 The GPIO interrupts are edge-triggered.

Table 74. Interrupt Mask 1 (INT_MSK1) [0xE1] [R/W]

Bit #	7	6	5	4	3	2	1	0
Field	Reserved	Prog Interval Timer Int Enable	1 ms Timer Int Enable	Reserved				
Read/Write	R/W	R/W	R/W	–	–	–	–	–
Default	0	0	0	0	0	0	0	0

- Bit 7** Reserved
- Bit 6** Prog Interval Timer Interrupt Enable
0 = Mask Prog Interval Timer interrupt
1 = Unmask Prog Interval Timer interrupt
- Bit 5** 1 ms Timer Interrupt Enable
0 = Mask 1 ms interrupt
1 = Unmask 1 ms interrupt
- Bit 4:0** Reserved

Table 75. Interrupt Mask 0 (INT_MSK0) [0xE0] [R/W]

Bit #	7	6	5	4	3	2	1	0
Field	GPIO Port 1 Int Enable	Sleep Timer Int Enable	INT1 Int Enable	GPIO Port 0 Int Enable	SPI Receive Int Enable	SPI Transmit Int Enable	Reserved	POR/LVD Int Enable
Read/Write	R/W	R/W	R/W	R/W	R/W	R/W	R/W	R/W
Default	0	0	0	0	0	0	0	0

- Bit 7** GPIO Port 1 Interrupt Enable
0 = Mask GPIO Port 1 interrupt
1 = Unmask GPIO Port 1 interrupt
- Bit 6** Sleep Timer Interrupt Enable
0 = Mask Sleep Timer interrupt
1 = Unmask Sleep Timer interrupt
- Bit 5** INT1 Interrupt Enable
0 = Mask INT1 interrupt
1 = Unmask INT1 interrupt
- Bit 4** GPIO Port 0 Interrupt Enable
0 = Mask GPIO Port 0 interrupt
1 = Unmask GPIO Port 0 interrupt
- Bit 3** SPI Receive Interrupt Enable
0 = Mask SPI Receive interrupt
1 = Unmask SPI Receive interrupt
- Bit 2** SPI Transmit Enable
0 = Mask SPI Transmit interrupt
1 = Unmask SPI Transmit interrupt
- Bit 1** Reserved
- Bit 0** POR/LVD Interrupt Enable
0 = Mask POR/LVD interrupt
1 = Unmask POR/LVD interrupt

Interrupt Vector Clear Register

Table 76. Interrupt Vector Clear Register (INT_VC) [0xE2] [R/W]

Bit #	7	6	5	4	3	2	1	0
Field	Pending Interrupt [7:0]							
Read/Write	R/W	R/W	R/W	R/W	R/W	R/W	R/W	R/W
Default	0	0	0	0	0	0	0	0

The Interrupt Vector Clear Register (INT_VC) holds the interrupt vector for the highest priority pending interrupt when read, and when written clears all pending interrupts.

Bits 7:0 Pending Interrupt [7:0]

8-bit data value holds the interrupt vector for the highest priority pending interrupt. Writing to this register clears all pending interrupts.

Microcontroller Function Register Summary

Addr	Name	7	6	5	4	3	2	1	0	R/W	Default
00	P0DATA	P0.7	Reserved	Reserved	P0.4/INT2	P0.3/INT1	Reserved	P0.1	Reserved	b--bb-b-	00000000
01	P1DATA	P1.7	P1.6/SMISO	P1.5/SMOSI	P1.4/SCLK	P1.3/SSEL	P1.2	P1.1	P1.0	bbbbbbb-	00000000
02	P2DATA	Reserved						P2.1–P2.0		-----bb	00000000
06	P01CR	Reserved	Int Enable	Int Act Low	TTL Thresh	High Sink	Open Drain	Pull up Enable	Output Enable	bbbbbbbbb	00000000
08–09	P03CR–P04CR	Reserved		Int Act Low	TTL Thresh	Reserved	Open Drain	Pull up Enable	Output Enable	--bb-bbb	00000000
0C	P07CR	Reserved	Int Enable	Int Act Low	TTL Thresh	Reserved	Open Drain	Pull up Enable	Output Enable	-bbb-bbb	00000000
0D	P10CR	Reserved	Int Enable	Int Act Low	Reserved			5K pullup Enable	Output enable	bbb----b	00000000
0E	P11CR	Reserved	Int Enable	Int Act Low	Reserved		Open Drain	Reserved	Output Enable	-bb--b-b	00000000
0F	P12CR	CLK Output	Int Enable	Int Act Low	TTL Threshold	Reserved	Open Drain	Pull up Enable	Output Enable	bbbb-bbb	00000000
10	P13CR	Reserved	Int Enable	Int Act Low	Reserved	High Sink	Open Drain	Pull up Enable	Output Enable	-bb-bbbb	00000000
11–13	P14CR–P16CR	SPI Use	Int Enable	Int Act Low	Reserved	High Sink	Open Drain	Pull up Enable	Output Enable	bbb-bbbb	00000000
14	P17CR	Reserved	Int Enable	Int Act Low	Reserved	High Sink	Open Drain	Pull up Enable	Output Enable	-bb-bbbb	00000000
15	P2CR	Reserved	Int Enable	Int Act Low	TTL Thresh	High Sink	Open Drain	Pull up Enable	Output Enable	-bbbbbbb	00000000
20	FRTMRL	Free Running Timer [7:0]								bbbbbbbbb	00000000
21	FRTMRH	Free Running Timer [15:8]								bbbbbbbbb	00000000
26	PITMRL	Prog Interval Timer [7:0]								rrrrrrrr	00000000
27	PITMRH	Reserved				Prog Interval Timer [11:8]				----rrrr	00000000
28	PIRL	Prog Interval [7:0]								bbbbbbbbb	00000000
29	PIRH	Reserved				Prog Interval [11:8]				----rrrr	00000000
30	CPUCLKCR	Reserved								-----	00000000
31	TMRCLKCR	TCAPCLK Divider		TCAPCLK Select		ITMRCLK Divider		ITMRCLK Select		bbbbbbbbb	10001111
34	IOSCTR	offset[2:0]			Gain[4:0]					bbbbbbbbb	000dddd
36	LPOSCTR	32 kHz Low Power	Reserved	32 kHz Bias Trim [1:0]		32 kHz Freq Trim [3:0]			0-bbbbb	d-ddddd	
3C	SPIDATA	SPIData[7:0]								bbbbbbbbb	00000000
3D	SPICR	Swap	LSB First	Comm Mode		CPOL	CPHA	SCLK Select		bbbbbbbbb	00000000
DA	INT_CLR0	GPIO Port 1	Sleep Timer	INT1	GPIO Port 0	SPI Receive	SPI Transmit	Reserved	POR/LVD	bbbbbb-b	00000000
DB	INT_CLR1	Reserved	Prog Interval Timer	1 ms Timer	Reserved				-bb----	00000000	
DC	INT_CLR2	Reserved	Reserved	Reserved	GPIO Port 2	Reserved	INT2	16-bit Counter Wrap	Reserved	---b-bb-	00000000

Microcontroller Function Register Summary (continued)

Addr	Name	7	6	5	4	3	2	1	0	R/W	Default	
DE	INT_MSK3	ENSWINT	Reserved								r-----	00000000
DF	INT_MSK2	Reserved	Reserved	Reserved	GPIO Port 2 Int Enable	Reserved	INT2 Int Enable	16-bit Counter Wrap Int Enable	Reserved	---b-bb-	00000000	
E0	INT_MSK0	GPIO Port 1 Int Enable	Sleep Timer Int Enable	INT1 Int Enable	GPIO Port 0 Int Enable	SPI Receive Int Enable	SPI Transmit Int Enable	Reserved	POR/LVD Int Enable	bbbbbb-b	00000000	
E1	INT_MSK1	Reserved	Prog Interval Timer Int Enable	1 ms Timer Int Enable	Reserved					-bb-----	00000000	
E2	INT_VC	Pending Interrupt [7:0]								bbbbbbbbb	00000000	
E3	RESWDT	Reset Watchdog Timer [7:0]								wwwwwwww w	00000000	
--	CPU_A	Temporary Register T1 [7:0]								-----	00000000	
--	CPU_X	X[7:0]								-----	00000000	
--	CPU_PCL	Program Counter [7:0]								-----	00000000	
--	CPU_PCH	Program Counter [15:8]								-----	00000000	
--	CPU_SP	Stack Pointer [7:0]								-----	00000000	
F7	CPU_F	Reserved			XIO	Super	Carry	Zero	Global IE	---brbbb	00000010	
FF	CPU_SCR	GIES	Reserved	WDRS	PORS	Sleep	Reserved	Reserved	Stop	r-ccb--b	00010100	
1E0	OSC_CR0	Reserved		No Buzz	Sleep Timer [1:0]		CPU Speed [2:0]			--bbbbbb	00001000	
1E3	LVD CR	Reserved		PORLEV[1:0]		Reserved	VM[2:0]			--bb-bbb	00000000	
1E4	VLTCMP	Reserved						LVD	PPOR	-----rr	00000000	
1EB	ECO_TR	Sleep Duty Cycle [1:0]		Reserved						bb-----	00000000	

Radio Function Register Summary

Address	Mnemonic	b7	b6	b5	b4	b3	b2	b1	b0	Default ^[4]	Access ^[4]		
0x00	CHANNEL_ADR	Not Used		Channel								-1001000	-bbbbbbb
0x01	TX_LENGTH_ADR	TX Length										00000000	bbbbbbb
0x02	TX_CTRL_ADR	TX GO	TX CLR	TXB15 IRQEN	TXB8 IRQEN	TXB0 IRQEN	TXBERR IRQEN	TXC IRQEN	TXE IRQEN	00000011	bbbbbbb		
0x03	TX_CFG_ADR	Not Used	Not Used	DATA CODE LENGTH	DATA MODE			PA SETTING			--000101	--bbbbbb	
0x04	TX_IRQ_STATUS_ADR	OS IRQ	LV IRQ	TXB15 IRQ	TXB8 IRQ	TXB0 IRQ	TXBERR IRQ	TXC IRQ	TXE IRQ	-----	rrrrrrr		
0x05	RX_CTRL_ADR	RX GO	RSVD	RXB16 IRQEN	RXB8 IRQEN	RXB1 IRQEN	RXBERR IRQEN	RXC IRQEN	RXE IRQEN	00000111	bbbbbbb		
0x06	RX_CFG_ADR	AGC EN	LNA	ATT	HILO	FASTTURN EN	Not Used	RXOW EN	VLD EN	10010-10	bbbbbb-bb		
0x07	RX_IRQ_STATUS_ADR	RXOW IRQ	SOPDET IRQ	RXB16 IRQ	RXB8 IRQ	RXB1 IRQ	RXBERR IRQ	RXC IRQ	RXE IRQ	-----	brrrrrr		
0x08	RX_STATUS_ADR	RX ACK	PKT ERR	EOP ERR	CRC0	Bad CRC	RX Code	RX Data Mode			-----	rrrrrrr	
0x09	RX_COUNT_ADR	RX Count									00000000	rrrrrrr	
0x0A	RX_LENGTH_ADR	RX Length										00000000	rrrrrrr
0x0B	PWR_CTRL_ADR	PMU EN	LVIRQ EN	PMU Mode Force	PFET disable	LVI TH		PMU OUTV			10100000	bbb-bbbb	
0x0C	XTAL_CTRL_ADR	XOUT FN		XSIRQ EN	Not Used	Not Used	FREQ				000-100	bbb-bbb	
0x0D	IO_CFG_ADR	IRQ OD	IRQ POL	MISO OD	XOUT OD	PACTL OD	PACTL GPIO	SPT 3PIN	IRQ GPIO	00000000	bbbbbbb		
0x0E	GPIO_CTRL_ADR	XOUT OP	MISO OP	PACTL OP	IRQ OP	XOUT IP	MISO IP	PACTL IP	IRQ IP	0000----	bbbrrrr		
0x0F	XACT_CFG_ADR	ACK EN	Not Used	FRC END	END STATE			ACK TO			1-000000	b-bbbbbb	
0x10	FRAMING_CFG_ADR	SOP EN	SOP LEN	LEN EN	SOP TH					10100101	bbbbbbb		
0x11	DATA32_THOLD_ADR	Not Used	Not Used	Not Used	Not Used	TH32					----0100	---bbbbb	
0x12	DATA64_THOLD_ADR	Not Used	Not Used	Not Used	TH64					---01010	---bbbbb		
0x13	RSSI_ADR	SOP	Not Used	LNA	RSSI					0-100000	r-rrrrr		
0x14	EOP_CTRL_ADR ^[8]	HEN	HINT			EOP					10100100	bbbbbbb	
0x15	CRC_SEED_LSB_ADR	CRC SEED LSB										00000000	bbbbbbb
0x16	CRC_SEED_MSB_ADR	CRC SEED MSB										00000000	bbbbbbb
0x17	TX_CRC_LSB_ADR	CRC LSB										-----	rrrrrrr
0x18	TX_CRC_MSB_ADR	CRC MSB										-----	rrrrrrr
0x19	RX_CRC_LSB_ADR	CRC LSB										11111111	rrrrrrr
0x1A	RX_CRC_MSB_ADR	CRC MSB										11111111	rrrrrrr
0x1B	TX_OFFSET_LSB_ADR	STRIM LSB										00000000	bbbbbbb
0x1C	TX_OFFSET_MSB_ADR	Not Used	Not Used	Not Used	Not Used	STRIM MSB					----0000	----bbbb	
0x1D	MODE_OVERRIDE_ADR	RSVD	RSVD	FRC SEN	FRC AWAKE		Not Used	Not Used	RST	00000-0	wwwww-w		
0x1E	RX_OVERRIDE_ADR	ACK RX	RXTX DLY	MAN RXACK	FRC RXDR	DIS CRC0	DIS RXCRC	ACE	Not Used	00000000-	bbbbbbb-		
0x1F	TX_OVERRIDE_ADR	ACK TX	FRC PRE	RSVD	MAN TXACK	OVRD ACK	DIS TXCRC	RSVD	TX INV	00000000	bbbbbbb		
0x26	XTAL_CFG_ADR	RSVD	RSVD	RSVD	RSVD	START DLY	RSVD	RSVD	RSVD	00000000	wwwwwww		
0x27	CLK_OVERRIDE_ADR	RSVD	RSVD	RSVD	RSVD	RSVD	RSVD	RXF	RSVD	00000000	wwwwwww		
0x28	CLK_EN_ADR	RSVD	RSVD	RSVD	RSVD	RSVD	RSVD	RXF	RSVD	00000000	wwwwwww		
0x29	RX_ABORT_ADR	RSVD	RSVD	ABORT EN	RSVD	RSVD	RSVD	RSVD	RSVD	00000000	wwwwwww		
0x32	AUTO_CAL_TIME_ADR	AUTO_CAL_TIME									00000011	wwwwwww	
0x35	AUTO_CAL_OFFSET_ADR	AUTO_CAL_OFFSET									00000000	wwwwwww	
0x39	ANALOG_CTRL_ADR	RSVD	RSVD	RSVD	RSVD	RSVD	RSVD	RX INV	ALL SLOW	00000000	wwwwwww		
Register Files													
0x20	TX_BUFFER_ADR	TX Buffer File									-----	wwwwwww	
0x21	RX_BUFFER_ADR	RX Buffer File									-----	rrrrrrr	
0x22	SOP_CODE_ADR	SOP Code File									Note [5]	bbbbbbb	
0x23	DATA_CODE_ADR	Data Code File									Note [6]	bbbbbbb	
0x24	PREAMBLE_ADR	Preamble File									Note [7]	bbbbbbb	
0x25	MFG_ID_ADR	MFG ID File									NA	rrrrrrr	

All registers are read and writable, except where noted. Registers may be written to or read from either individually or in sequential groups. A single-byte read or write reads or writes from the addressed register. Incrementing burst read and write is a sequence that begins with an address, and then reads or writes to/from each register in address order for as long as clocking continues. It is possible to repeatedly read (poll) a single register using a nonincrementing burst read.

Notes

- b = read/write; r = read only; w = write only; '-' = not used, default value is undefined.
- SOP_CODE_ADR default = 0x17FF9E213690C782.
- DATA_CODE_ADR default = 0x02F9939702FA5CE3012BF1DB0132BE6F.
- PREAMBLE_ADR default = 0x333302; The count value must be greater than 4 for DDR and greater than 8 for SDR.
- Registers must be configured or accessed only when the radio is in IDLE or SLEEP mode. The PMU, GPIOs, RSSI registers can be accessed in Active Tx and Rx mode.
- EOP_CTRL_ADR[6:4] must never have the value of "000" i.e. EOP Hint Symbol count must never be "0"

Absolute Maximum Ratings

Exceeding maximum ratings may shorten the useful life of the device. User guidelines are not tested.

Storage Temperature -40 °C to +90 °C
 Ambient Temperature with Power Applied 0 °C to +70 °C
 Supply Voltage on any power supply pin relative to V_{SS} -0.3 V to +3.9 V

DC Voltage to Logic Inputs ^[11] -0.3 V to V_{IO} + 0.3 V
 DC Voltage applied to Outputs in High Z State -0.3 V to V_{IO} + 0.3 V
 Static Discharge Voltage (Digital) ^[12] >2000 V
 Static Discharge Voltage (RF) ^[12] 1100 V
 Latch up Current +200 mA, -200 mA
 Ground Voltage 0 V
 F_{OSC} (Crystal Frequency) 12 MHz ±30 ppm

DC Characteristics

(T = 25 °C)

Parameter	Description	Conditions	Min	Typ	Max	Unit
V _{BAT}	Battery Voltage	0-70 °C	1.8	-	3.6	V
V _{REG} ^[13]	PMU Output Voltage	2.7V mode	2.7	2.73	-	V
V _{LVD}	Low Voltage Detect	LVDCR [2:0] set to 000	2.69	2.7	2.72	V
		LVDCR [2:0] set to 001	2.90	2.92	2.94	V
		LVDCR [2:0] set to 010	3.00	3.02	3.04	V
		LVDCR [2:0] set to 011	3.10	3.13	3.15	V
V _{IO}	V _{IO} Voltage		1.8	-	3.6	V
V _{CC}	V _{CC} Voltage	0-70 °C	2.4	-	3.6	V
Device Current (For total current consumption in different modes, for example Radio, active, MCU, and sleep, add Radio Function Current and MCU Function Current)						
I _{CC} (GFSK) ^[14]	Average I _{CC} , 1 Mbps, slow channel	PA = 5, 2-way, 4 bytes/10 ms CPU speed = 6 MHz	-	9.87	-	mA
I _{CC} (32-8DR) ^[14]	Average I _{CC} , 250 kbps, fast channel	PA = 5, 2-way, 4 bytes/10 ms CPU speed = 6 MHz	-	10.2	-	mA
I _{SB1}	Sleep Mode I _{CC}	V _{CC} = 3.0V, MCU sleep, PMU disabled	-	2.72	-	µA
I _{SB2}	Sleep Mode I _{CC}	V _{CC} = 3.0V, MCU sleep, PMU enabled	-	30.4	-	µA

Notes

- 11. It is permissible to connect voltages above V_{IO} to inputs through a series resistor limiting input current to 1 mA. AC timing not guaranteed.
- 12. Human Body Model (HBM).
- 13. V_{REG} depends on battery input voltage.
- 14. Includes current drawn while starting crystal, starting synthesizer, transmitting packet (including SOP and CRC16), changing to receive mode, and receiving ACK handshake. Device is in sleep except during this transaction.

DC Characteristics (continued)

(T = 25 °C)

Parameter	Description	Conditions	Min	Typ	Max	Unit
Radio Function Currents ($V_{CC} = 3.0\text{ V}$, MCU Sleep)						
IDLE I_{CC}	Radio off, XTAL Active	XOUT disabled	–	1.1	–	mA
I_{synth}	I_{CC} during Synth Start		–	8.6	–	mA
TX I_{CC}	I_{CC} during Transmit	PA = 5 (–5 dBm)	–	21.2	–	mA
TX I_{CC}	I_{CC} during Transmit	PA = 6 (0 dBm)	–	28.5	–	mA
TX I_{CC}	I_{CC} during Transmit	PA = 7 (+4 dBm)	–	39.9	–	mA
RX I_{CC}	I_{CC} during Receive	LNA off, ATT on.	–	18.9	–	mA
RX I_{CC}	I_{CC} during Receive	LNA on, ATT off.	–	21.9	–	mA
Boost Eff	PMU Boost Converter Efficiency	$V_{BAT} = 2.5\text{V}$, $V_{REG} = 2.73\text{V}$, $I_{LOAD} = 20\text{ mA}$	–	83	–	%
$I_{LOAD_EXT}^{[15]}$	Average PMU External Load current	$V_{BAT} = 1.8\text{V}$, $V_{REG} = 2.73\text{V}$, RX Mode	–	–	15	mA
MCU Function Currents ($V_{DD} = 3.0\text{V}$)						
I_{DD1}	V_{DD} Operating Supply Current	CPU speed = 6 MHz	–	5.0	–	mA
I_{DD1}	V_{DD} Operating Supply Current	CPU speed = 3 MHz	–	4.4	–	mA
Radio Function GPIO Interface						
V_{OH1}	Output High Voltage Condition 1	At $I_{OH} = -100.0\ \mu\text{A}$	$V_{IO} - 0.1$	V_{IO}	–	V
V_{OH2}	Output High Voltage Condition 2	At $I_{OH} = -2.0\ \text{mA}$	$V_{IO} - 0.4$	V_{IO}	–	V
V_{OL}	Output Low Voltage	At $I_{OL} = 2.0\ \text{mA}$	–	0	0.4	V
V_{IH}	Input High Voltage		$0.76V_{IO}$	–	V_{IO}	V
V_{IL}	Input Low Voltage		0	–	$0.24V_{IO}$	V
I_{IL}	Input Leakage Current	$0 < V_{IN} < V_{IO}$	–1	0.26	+1	μA
C_{IN}	Pin Input Capacitance	except XTAL, RF_N , RF_P , RF_{BIAS}	–	3.5	10	pF
MCU Function GPIO Interface						
R_{UP}	Pull up Resistance		4	–	12	$\text{K}\Omega$
V_{ICR}	Input Threshold Voltage Low, CMOS mode	Low to High edge	40%	–	65%	V_{CC}
V_{ICF}	Input Threshold Voltage Low, CMOS mode	High to Low edge	30%	–	55%	V_{CC}
V_{HC}	Input Hysteresis Voltage, CMOS Mode	High to low edge	3%	–	10%	V_{CC}
V_{ILTTL}	Input Low Voltage, TTL Mode		–	–	0.72	V
V_{IHTTL}	Input HIGH Voltage, TTL Mode		1.6	–	–	V
V_{OL1}	Output Low Voltage, High Drive ^[16]	$I_{OL1} = 50\ \text{mA}$	–	–	1.4	V
V_{OL2}	Output Low Voltage, High Drive ^[16]	$I_{OL1} = 25\ \text{mA}$	–	–	0.4	V
V_{OL3}	Output Low Voltage, Low Drive	$I_{OL2} = 8\ \text{mA}$	–	–	0.8	V
V_{OH}	Output High Voltage ^[17]	$I_{OH} = 2\ \text{mA}$	$V_{CC} - 0.5$	–	–	V

Notes

15. I_{LOAD_EXT} is dependant on external components and this entry applies when the components connected to L/D are SS12 series diode and DH53100LC inductor from Sumida.

16. Available only on P1.3,P1.4,P1.5,P1.6,P1.7.

17. Except for pins P1.0, P1.1 in GPIO mode.

AC Characteristics

Parameter	Description	Conditions	Min	Typ	Max	Unit
GPIO Timing						
T _{R_GPIO}	Output Rise Time	Measured between 10 and 90% V _{dd} /V _{reg} with 50 pF load	–	–	50	ns
T _{F_GPIO}	Output Fall Time	Measured between 10 and 90% V _{dd} /V _{reg} with 50 pF load	–	–	15	ns
F _{IMO}	Internal Main Oscillator Frequency	With proper trim values loaded ^[5]	18.72	–	26.4	MHz
F _{ILO}	Internal Low Power Oscillator	With proper trim values loaded ^[5]	15.0001	–	50.0	kHz
SPI Timing						
T _{SMCK}	SPI Master Clock Rate	F _{CPUCLK} /6	–	–	2	MHz
T _{SSCK}	SPI Slave Clock Rate		–	–	2.2	MHz
T _{SCKH}	SPI Clock High Time	High for CPOL = 0, Low for CPOL = 1	125	–	–	ns
T _{SCKL}	SPI Clock Low Time	Low for CPOL = 0, High for CPOL = 1	125	–	–	ns
T _{MDO}	Master Data Output Time ^[18]	SCK to data valid	–25	–	50	ns
T _{MDO1}	Master Data Output Time, First bit with CPHA = 0	Time before leading SCK edge	100	–	–	ns
T _{MSU}	Master Input Data Setup time		50	–	–	ns
T _{MHD}	Master Input Data Hold time		50	–	–	ns
T _{SSU}	Slave Input Data Setup Time		50	–	–	ns
T _{SHD}	Slave Input Data Hold Time		50	–	–	ns
T _{SDO}	Slave Data Output Time	SCK to data valid	–	–	100	ns
T _{SDO1}	Slave Data Output Time, First bit with CPHA = 0	Time after SS LOW to data valid	–	–	100	ns
T _{SSS}	Slave Select Setup Time	Before first SCK edge	150	–	–	ns
T _{SSH}	Slave Select Hold Time	After last SCK edge	150	–	–	ns

Figure 19. Clock Timing

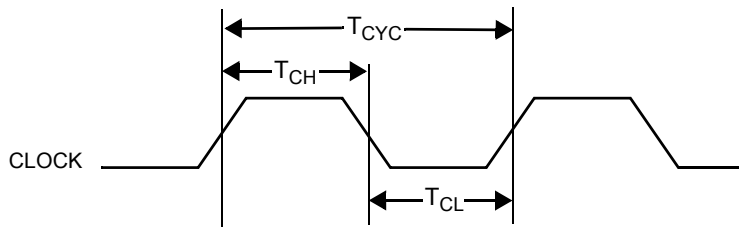

Note

18. In Master mode first bit is available 0.5 SPICLK cycle before Master clock edge available on the SCLK pin.

Figure 20. GPIO Timing Diagram

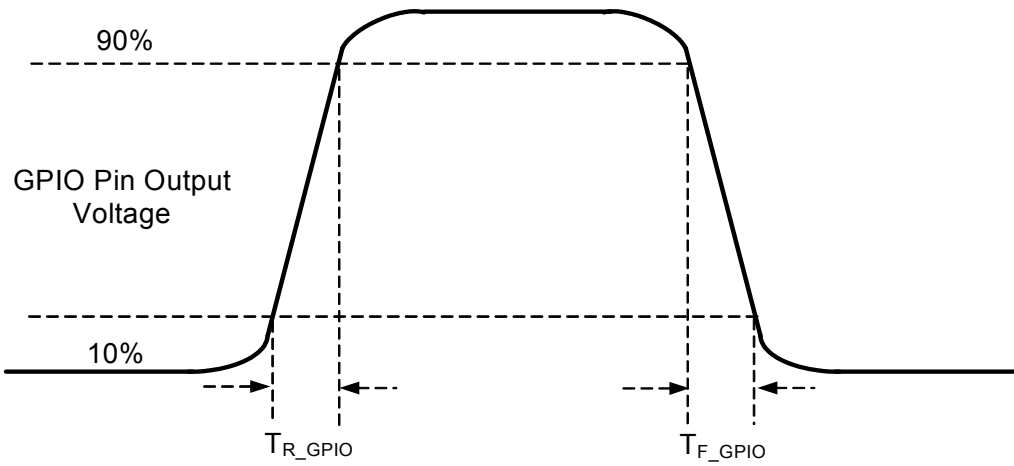

Figure 21. SPI Master Timing, CPHA = 1

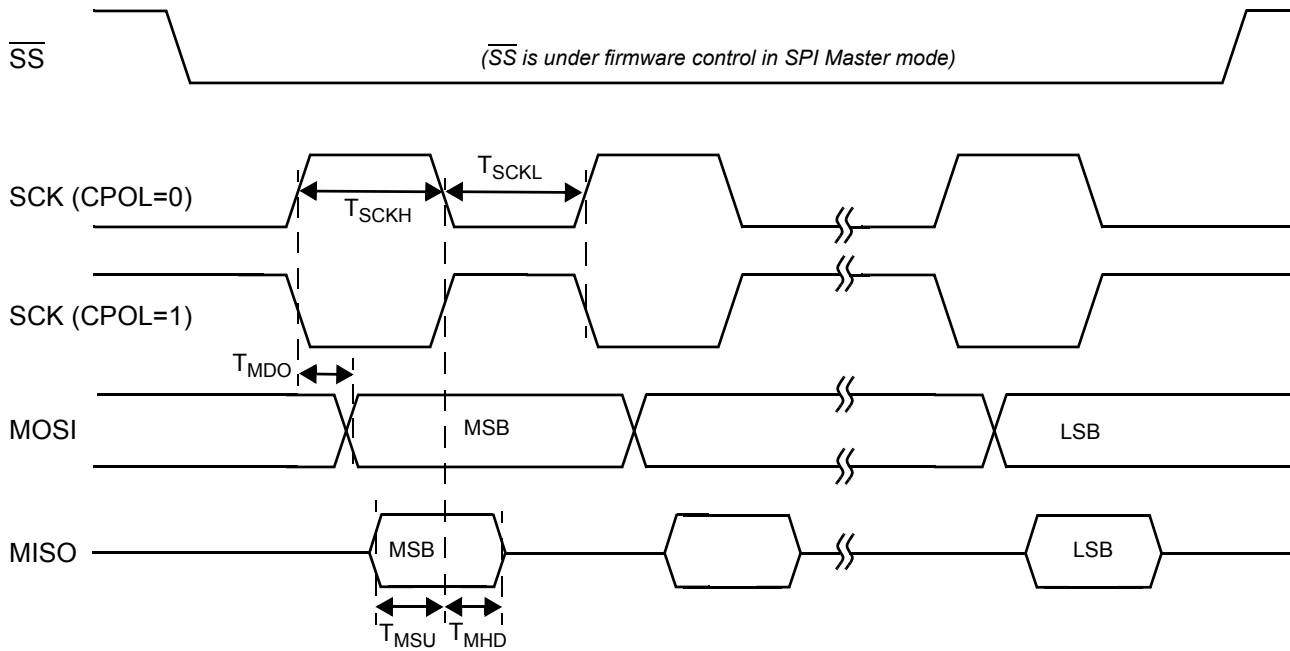

Figure 22. SPI Slave Timing, CPHA = 1

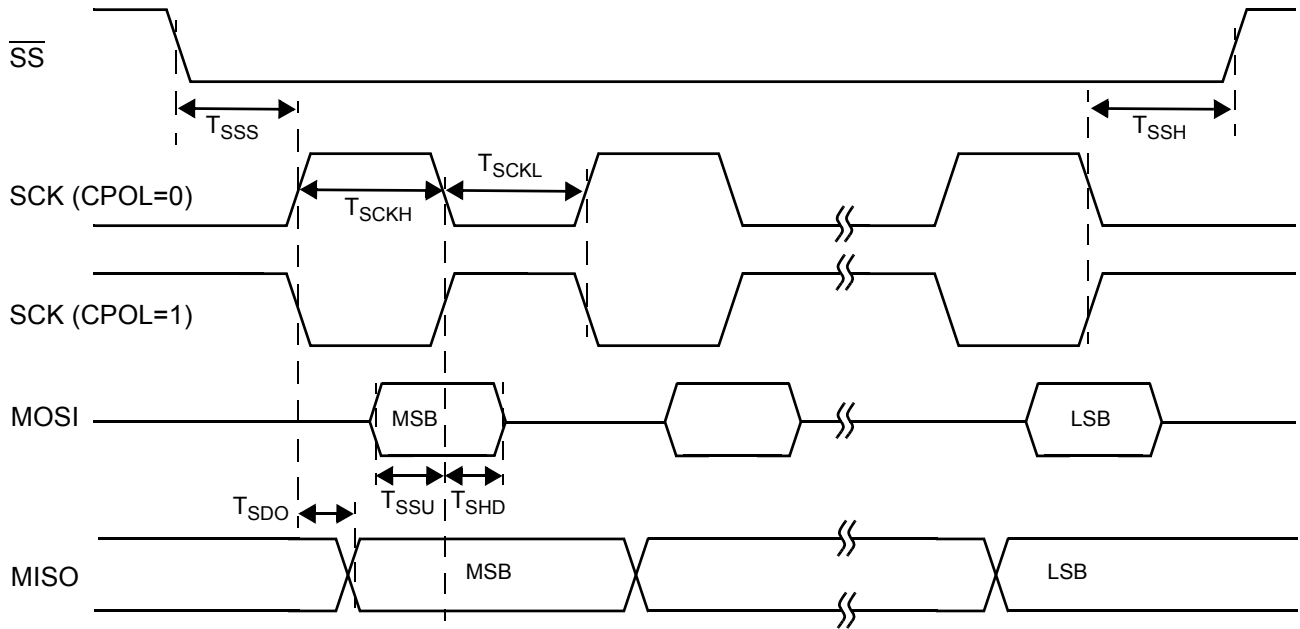

Figure 23. SPI Master Timing, CPHA = 0

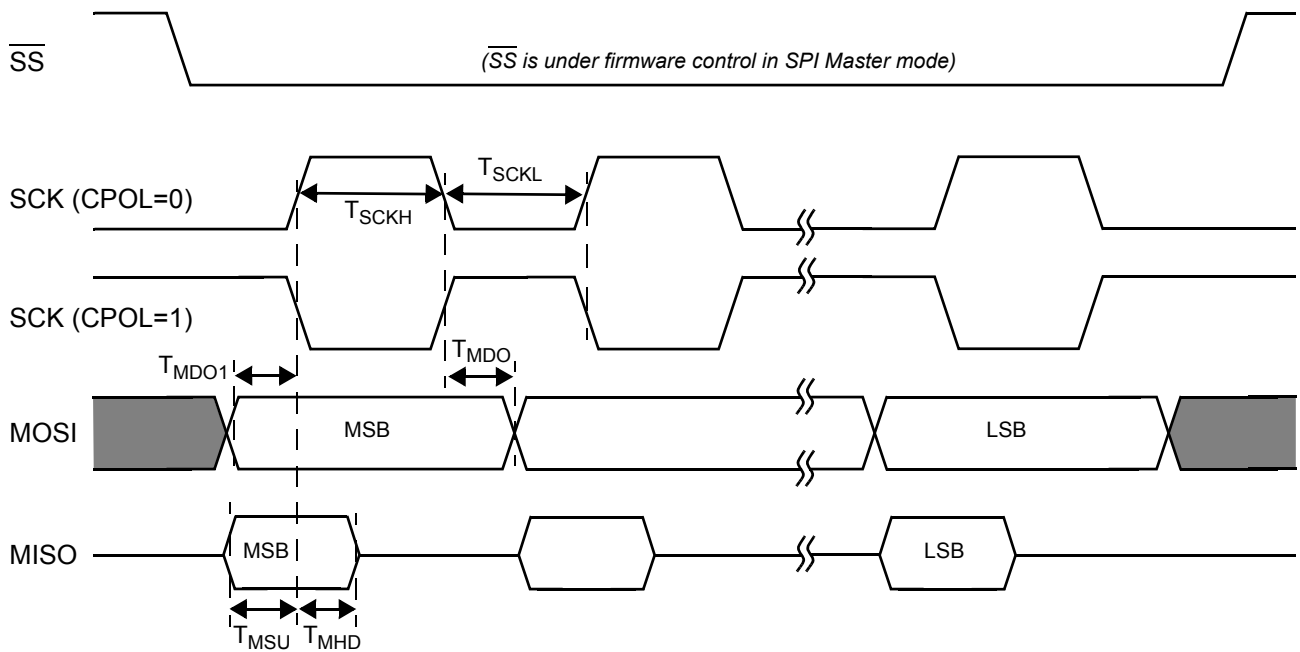
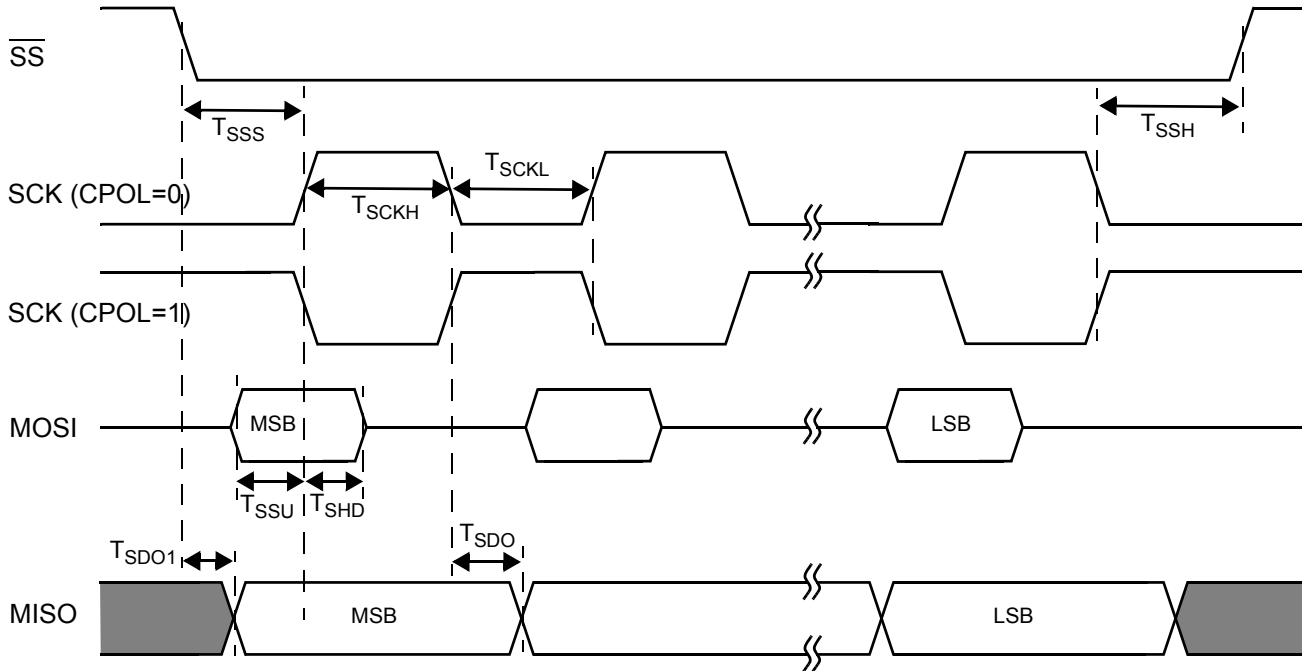

Figure 24. SPI Slave Timing, CPHA = 0



RF Characteristics

Table 77. Radio Parameters

Parameter Description	Conditions	Min	Typ	Max	Unit
RF Frequency Range	Subject to regulation	2.400	–	2.497	GHz
Receiver (T = 25 °C, V _{CC} = 3.0 V, f _{OSC} = 12.000 MHz, BER < 10 ⁻³)					
Sensitivity 125 kbps 64-8DR	BER 1E-3	–	–97	–	dBm
Sensitivity 250 kbps 32-8DR	BER 1E-3	–	–93	–	dBm
Sensitivity	CER 1E-3	–80	–87	–	dBm
Sensitivity GFSK	BER 1E-3, ALL SLOW = 1	–	–84	–	dBm
LNA Gain		–	22.8	–	dB
ATT Gain		–	–31.7	–	dB
Maximum Received Signal	LNA On	–15	–6	–	dBm
RSSI Value for PWR _{in} –60 dBm ^[19]	LNA On	–	21	–	Count
RSSI Slope		–	1.9	–	dB/Count
Interference Performance (CER 1E-3)					
Co-channel Interference rejection Carrier-to-Interference (C/I)	C = –60 dBm,	–	9	–	dB
Adjacent (±1 MHz) Channel Selectivity C/I 1 MHz	C = –60 dBm	–	3	–	dB
Adjacent (±2 MHz) Channel Selectivity C/I 2 MHz	C = –60 dBm	–	–30	–	dB
Adjacent (≥ 3 MHz) Channel Selectivity C/I ≥ 3 MHz	C = –67 dBm	–	–38	–	dB
Out-of-Band Blocking 30 MHz–12.75 MHz ^[20]	C = –67 dBm	–	–30	–	dBm
Intermodulation	C = –64 dBm, Δf = 5, 10 MHz	–	–36	–	dBm
Receive Spurious Emission					
800 MHz	100 kHz ResBW	–	–79	–	dBm
1.6 GHz	100 kHz ResBW	–	–71	–	dBm
3.2 GHz	100 kHz ResBW	–	–65	–	dBm
Transmitter (T = 25°C, V _{CC} = 3.0V, f _{OSC} = 12.000 MHz)					
Maximum RF Transmit Power	PA = 7	+2	4	+6	dBm
Maximum RF Transmit Power	PA = 6	–2	0	+2	dBm
Maximum RF Transmit Power	PA = 5	–7	–5	–3	dBm
Maximum RF Transmit Power	PA = 0	–	–35	–	dBm
RF Power Control Range		–	39	–	dB
RF Power Range Control Step Size	seven steps, monotonic	–	5.6	–	dB
Frequency Deviation Min	PN Code Pattern 10101010	–	270	–	kHz
Frequency Deviation Max	PN Code Pattern 11110000	–	323	–	kHz
Error Vector Magnitude (FSK error)	>0 dBm	–	10	–	%rms
Occupied Bandwidth	–6 dBc, 100 kHz ResBW	500	876	–	kHz

Notes

- 19. RSSI value is not guaranteed. Extensive variation from part to part.
- 20. Exceptions F/3 & 5C/3.

Table 77. Radio Parameters (continued)

Parameter Description	Conditions	Min	Typ	Max	Unit
Transmit Spurious Emission (PA = 7)					
In-band Spurious Second Channel Power (± 2 MHz)		–	–38	–	dBm
In-band Spurious Third Channel Power (≥ 3 MHz)		–	–44	–	dBm
Non-Harmonically Related Spurs (8.000 GHz)		–	–38	–	dBm
Non-Harmonically Related Spurs (1.6 GHz)		–	–34	–	dBm
Non-Harmonically Related Spurs (3.2 GHz)		–	–47	–	dBm
Harmonic Spurs (Second Harmonic)		–	–43	–	dBm
Harmonic Spurs (Third Harmonic)		–	–48	–	dBm
Fourth and Greater Harmonics		–	–59	–	dBm
Power Management (Crystal PN# eCERA GF-1200008)					
Crystal Start to 10ppm		–	0.7	1.3	ms
Crystal Start to IRQ	XSIRQ EN = 1	–	0.6	–	ms
Synth Settle	Slow channels	–	–	270	μ s
Synth Settle	Medium channels	–	–	180	μ s
Synth Settle	Fast channels	–	–	100	μ s
Link Turnaround Time	GFSK	–	–	30	μ s
Link Turnaround Time	250 kbps	–	–	62	μ s
Link Turnaround Time	125 kbps	–	–	94	μ s
Link Turnaround Time	<125 kbps	–	–	31	μ s
Max. packet length	< 60 ppm crystal-to-crystal all modes except 64-DDR and 64-SDR	–	–	40	bytes
Max. packet length	< 60 ppm crystal-to-crystal 64-DDR and 64-SDR	–	–	16	bytes

Ordering Information

Package	Ordering Part Number	Status
40-pin Pb-Free QFN 6 × 6 mm (Sawn)	CYRF69103-40LTXC	In Production
40-pin Pb-free QFN 6 × 6 mm (Punch)	CYRF69103-40LFXC	NRND

Ordering Code Definitions

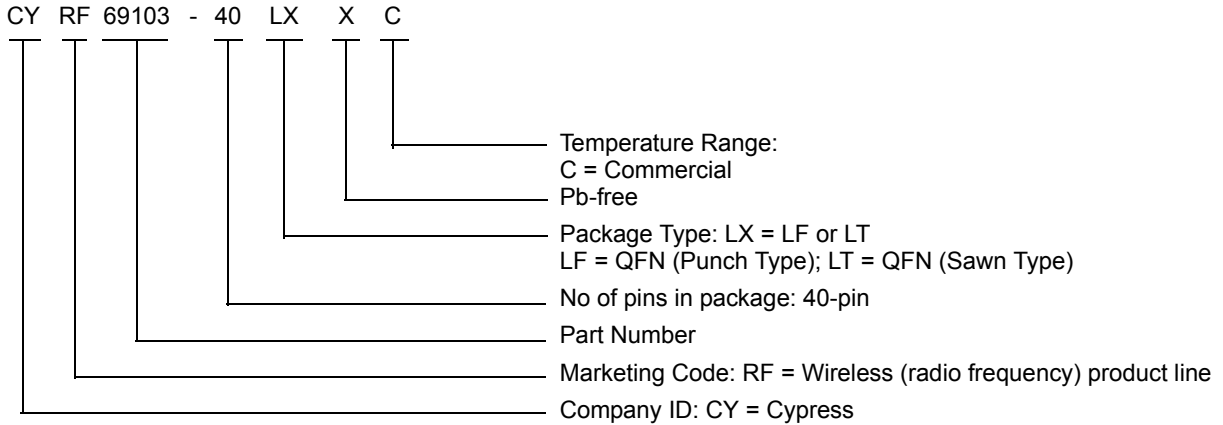

Package Handling

Some IC packages require baking before they are soldered onto a PCB to remove moisture that may have been absorbed after leaving the factory. A label on the packaging has details about actual bake temperature and the minimum bake time to remove this moisture. The maximum bake time is the aggregate time that the parts are exposed to the bake temperature. Exceeding this exposure time may degrade device reliability.

Table 78. Package Handling

Parameter	Description	Min	Typ	Max	Unit
T _{BAKETEMP}	Bake Temperature		125	see package label	°C
T _{BAKETIME}	Bake Time	see package label		72	hours

Package Diagram

Figure 25. 40-pin QFN (6 × 6 × 1.0 mm) LT40B 3.50 × 3.50 E-Pad (Sawn) Package Outline, 001-13190

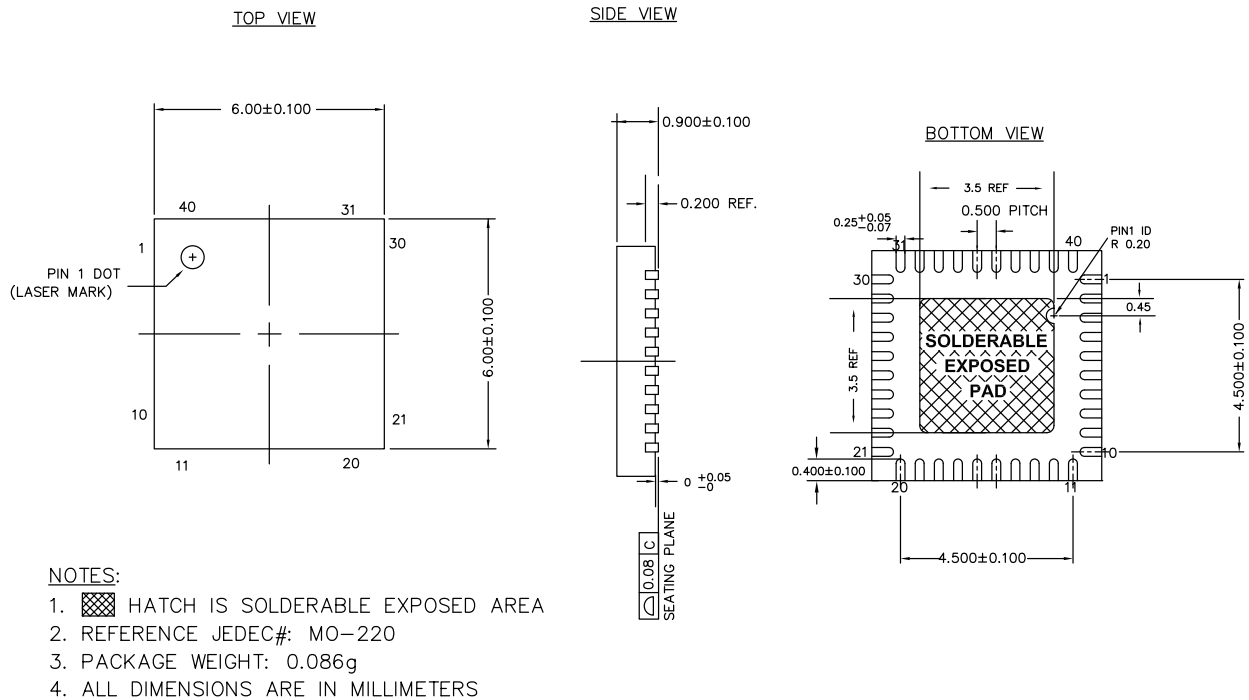

001-13190 *H

Figure 26. 40-pin QFN (6 × 6 × 1.0 mm) LF40A/LY40A (3.50 × 3.50 mm) E-Pad (Punch) Package Outline, 001-12917 [21]

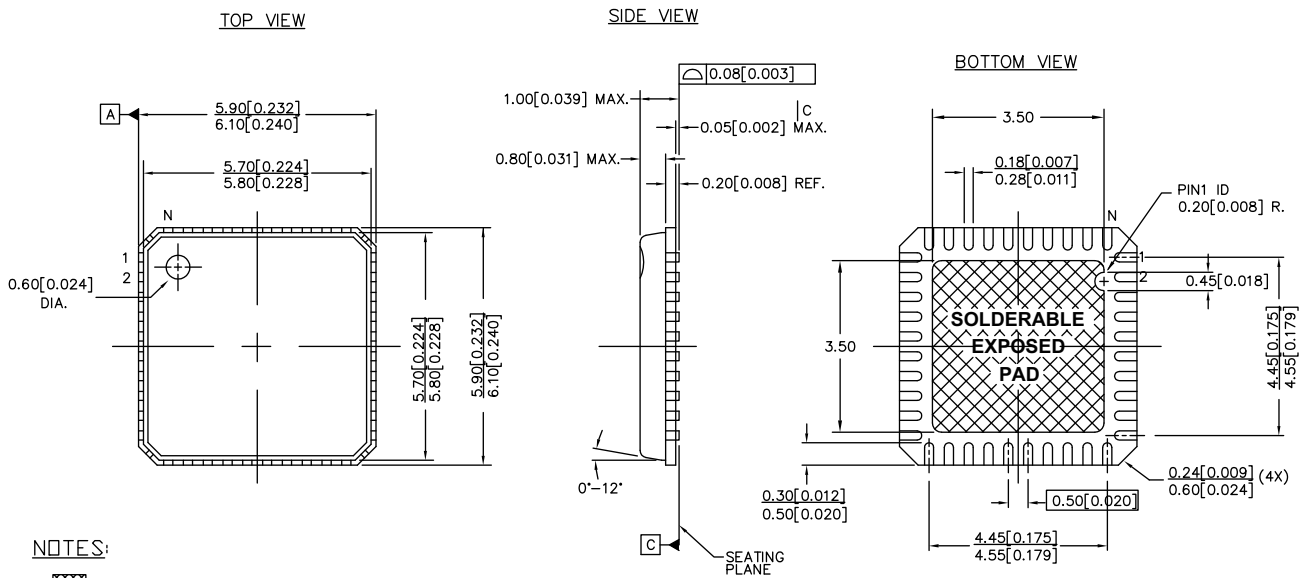

NOTES:

1.  HATCH IS SOLDERABLE EXPOSED AREA
2. REFERENCE JEDEC#: MO-220
3. PACKAGE WEIGHT: 0.086g
4. ALL DIMENSIONS ARE IN MM [MIN/MAX]
5. PACKAGE CODE

PART #	DESCRIPTION
LF40A	STANDARD
LY40A	PB-FREE

001-12917 °C

Note

21. Not Recommended for New Design.

Acronyms

Table 79. Acronyms Used in this Document

Acronym	Description
ACK	Acknowledge (packet received, no errors)
AGC	Automatic Gain Control
ATS	Auto Transaction Sequencer
CMOS	Complementary Metal Oxide Semiconductor
CPU	Central Processing Unit
EEPROM	Electrically Erasable Programmable Read-Only Memory
GFSK	Gaussian Frequency-Shift Keying
GPIO	General Purpose Input/Output
HID	Human Interface Devices
I/O	Input/Output
ISM	Industrial, Scientific, and Medical
LNA	Low Noise Amplifier
MCU	Microcontroller Unit
MOSI	Master Out Slave In
PMU	Power Management Unit
PSoC	Programmable System-on-Chip
QFN	Quad Flat No-lead
RAM	Random Access Memory
RSSI	Received Signal Strength Indication
SCK	Serial Clock
SPI	Serial Peripheral Interface
SRAM	Supervisory Read Only Memory
SS	Slave Select
TTL	Transistor-Transistor Logic

Document Conventions

Units of Measure

Table 80. Units of Measure

Symbol	Unit of Measure
°C	degree Celsius
dB	decibel
dBm	decibel-milliwatt
GHz	gigahertz
Hz	hertz
kHz	kilohertz
kΩ	kilohm
MHz	megahertz
μF	microfarad
μs	microsecond
μW	microwatt
mA	milliampere
mm	millimeter
ms	millisecond
mV	millivolt
ns	nanosecond
Ω	ohm
%	percent
ppm	parts per million
pF	picofarad
V	volt

Document History Page

Document Title: CYRF69103, Programmable Radio on Chip Low Power Document #: 001-07611				
Rev.	ECN No.	Orig. of Change	Submission Date	Description of Change
**	479801	OYR	See ECN	New advance data sheet.
*A	501282	OYR	See ECN	Preliminary data sheet. Created Preliminary data sheet from Advance Information.
*B	631696	BOO	See ECN	Final data sheet. Updated DC Characteristics table with characterization data. Minor text changes GPIO capacitance and timing diagram included Sleep and Wakeup sequence documented PIT Timer registers' R/W capability corrected to read only Updated radio function register descriptions Changed L/D pin description Changed RST Capacitor from 0.1 uF to 0.47 uF Added example PMU configuration circuits
*C	2447906	AESA	See ECN	Updated to new template
*D	2615458	KKU / AESA	01/13/2009	Replaced 51-85190 with 001-12917. Fixed format and language inconsistencies.
*E	2761532	DVJA	09/09/2009	Changed default value of the Sleep Timer from 00(512 Hz) to 01(64 Hz) in the OSC_CR0 [0x1E0] register.
*F	2885149	KKU	02/26/2010	Updated the following sections: Microcontroller Function , Clock Architecture Description , CPU Clock During Sleep Mode , Sleep Mode , Low Power in Sleep Mode , General Purpose I/O Ports , Microcontroller Function Register Summary , and Package Diagram
*G	3552304	ANTG	03/15/2012	Added sub-section Receive Spurious Response under the main section Functional Block Overview . Updated RF Characteristics (Updated Table 77 (Added Note 19 and referred the same note in the parameter "RSSI Value for PWR _{in} -60 dBm")). Added Ordering Code Definitions . Updated Package Diagram (Added Figure 25). Added Acronyms and Units of Measure .
*H	3717153	ANKC	08/21/2012	Updated Ordering Information (No change in part numbers, included a column "Status"). Updated Package Diagram (spec 001-13190 (Changed revision from *G to *H), added Note 21 and referred the same note in Figure 26).
*I	3913209	ANKC	02/25/2013	Updated Pinouts (Updated Figure 1). Updated Pin Definitions (Updated descriptions of Pin 21 and Pin 22). Updated Functional Block Overview (Updated 2.4 GHz Radio (Replaced seven steps with eight steps)). Updated General Purpose I/O Ports (Updated GPIO Port Configuration (Updated High Sink (Removed CY7C601xx, CY7C602xx related information), updated SPI Use (Removed CY7C601xx, CY7C602xx related information))).

Sales, Solutions, and Legal Information

Worldwide Sales and Design Support

Cypress maintains a worldwide network of offices, solution centers, manufacturer's representatives, and distributors. To find the office closest to you, visit us at [Cypress Locations](#).

Products

Automotive	cypress.com/go/automotive
Clocks & Buffers	cypress.com/go/clocks
Interface	cypress.com/go/interface
Lighting & Power Control	cypress.com/go/powerpsoc cypress.com/go/plc
Memory	cypress.com/go/memory
Optical & Image Sensing	cypress.com/go/image
PSoC	cypress.com/go/psoc
Touch Sensing	cypress.com/go/touch
USB Controllers	cypress.com/go/USB
Wireless/RF	cypress.com/go/wireless

PSoC Solutions

psoc.cypress.com/solutions
PSoC 1 | PSoC 3 | PSoC 5

© Cypress Semiconductor Corporation, 2006-2013. The information contained herein is subject to change without notice. Cypress Semiconductor Corporation assumes no responsibility for the use of any circuitry other than circuitry embodied in a Cypress product. Nor does it convey or imply any license under patent or other rights. Cypress products are not warranted nor intended to be used for medical, life support, life saving, critical control or safety applications, unless pursuant to an express written agreement with Cypress. Furthermore, Cypress does not authorize its products for use as critical components in life-support systems where a malfunction or failure may reasonably be expected to result in significant injury to the user. The inclusion of Cypress products in life-support systems application implies that the manufacturer assumes all risk of such use and in doing so indemnifies Cypress against all charges.

Any Source Code (software and/or firmware) is owned by Cypress Semiconductor Corporation (Cypress) and is protected by and subject to worldwide patent protection (United States and foreign), United States copyright laws and international treaty provisions. Cypress hereby grants to licensee a personal, non-exclusive, non-transferable license to copy, use, modify, create derivative works of, and compile the Cypress Source Code and derivative works for the sole purpose of creating custom software and or firmware in support of licensee product to be used only in conjunction with a Cypress integrated circuit as specified in the applicable agreement. Any reproduction, modification, translation, compilation, or representation of this Source Code except as specified above is prohibited without the express written permission of Cypress.

Disclaimer: CYPRESS MAKES NO WARRANTY OF ANY KIND, EXPRESS OR IMPLIED, WITH REGARD TO THIS MATERIAL, INCLUDING, BUT NOT LIMITED TO, THE IMPLIED WARRANTIES OF MERCHANTABILITY AND FITNESS FOR A PARTICULAR PURPOSE. Cypress reserves the right to make changes without further notice to the materials described herein. Cypress does not assume any liability arising out of the application or use of any product or circuit described herein. Cypress does not authorize its products for use as critical components in life-support systems where a malfunction or failure may reasonably be expected to result in significant injury to the user. The inclusion of Cypress' product in a life-support systems application implies that the manufacturer assumes all risk of such use and in doing so indemnifies Cypress against all charges.

Use may be limited by and subject to the applicable Cypress software license agreement.