

2K x 8 Reprogrammable PROM

Features

- Windowed for reprogrammability
- CMOS for optimum speed/power
- High speed
 - 20 ns (Commercial)
 - 35 ns (Military)
- Low power
 - 660 mW (Commercial and Military)
- Low standby power
 - 220 mW (Commercial and Military)
- EPROM technology 100% programmable
- Slim 300-mil or standard 600-mil packaging available
- 5V $\pm 10\%$ V_{CC} , commercial and military
- TTL-compatible I/O
- Direct replacement for bipolar PROMs
- Capable of withstanding >2001V static discharge

Functional Description

The CY7C291A is a high-performance 2K-word by 8-bit CMOS PROM. It is packaged in a 300-mil ceramic package which may be equipped with an erasure window; when exposed to UV light the PROM is erased and can then be reprogrammed. The memory cells utilize proven EPROM floating-gate technology and byte-wide intelligent programming algorithms.

The CY7C291A is a plug-in replacement for bipolar devices and offers the advantage of lower power, reprogrammability, superior performance and programming yield. The EPROM cell requires only 12.5V for the supervoltage and low current requirements allow for gang programming. The EPROM cells allow for each memory location to be tested 100%, as each location is written into, erased, and repeatedly exercised prior to encapsulation. Each PROM is also tested for AC performance to guarantee that after customer programming the product will meet DC and AC specification limits.

A read is accomplished by placing an active LOW signal on \overline{CS}_1 , and active HIGH signals on CS_2 and CS_3 . The contents of the memory location addressed by the address line (A_0 - A_{10}) will become available on the output lines (O_0 - O_7).

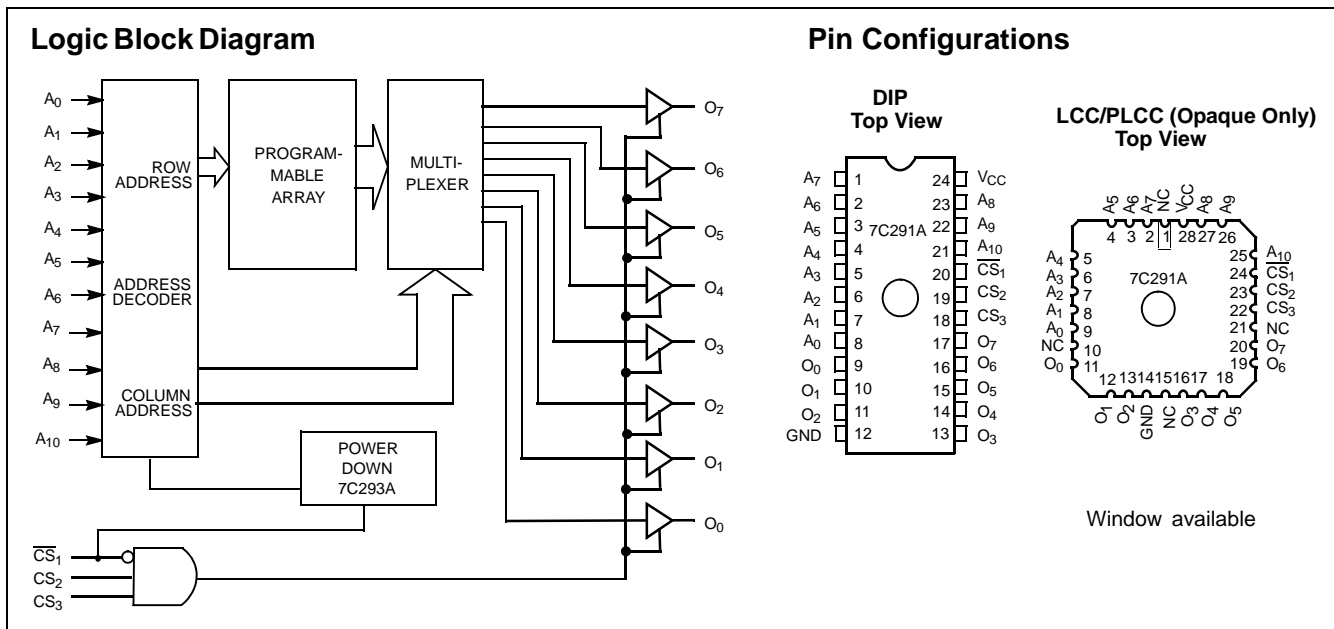

Selection Guide

			7C291A-20	7C291A-25	7C291A-35 7C291AL-35	7C291A-50	Unit
Maximum Access Time			20	25	35	50	ns
Maximum Operating Current	Standard	Commercial	120	90	90	90	mA
		Military			90		mA
	L	Commercial			60		mA

Maximum Ratings

(Above which the useful life may be impaired. For user guidelines, not tested.)

- Storage Temperature -65°C to +150°C
- Ambient Temperature with Power Applied..... -55°C to +125°C
- Supply Voltage to Ground Potential -0.5V to +7.0V
- DC Voltage Applied to Outputs in High Z State -0.5V to +7.0V
- DC Input Voltage -3.0V to +7.0V

- DC Program Voltage..... 13.0V
- UV Exposure 7258 Wsec/cm²
- Static Discharge Voltage..... >2001V (per MIL-STD-883, Method 3015)
- Latch-Up Current..... >200 mA

Operating Range

Range	Ambient Temperature	V _{CC}
Commercial	0°C to + 70°C	5V ±10%
Military ^[1]	-55°C to + 125°C	5V ±10%

Note

1. T_A is the "instant on" case temperature.

Electrical Characteristics Over the Operating Range^[2,3]

Parameter	Description	Test Conditions	7C291A-20		7C291A-25		Unit
			Min.	Max.	Min.	Max.	
V _{OH}	Output HIGH Voltage	V _{CC} = Min., I _{OH} = -4.0 mA	2.4		2.4		V
V _{OL}	Output LOW Voltage	V _{CC} = Min., I _{OL} = 16.0 mA		0.4		0.4	V
V _{IH}	Input HIGH Voltage	Guaranteed Input Logical HIGH Voltage for All Inputs	2.0	V _{CC}	2.0	V _{CC}	V
V _{IL}	Input LOW Voltage	Guaranteed Input Logical LOW Voltage for All Inputs		0.8		0.8	V
I _{IX}	Input Load Current	GND ≤ V _{IN} ≤ V _{CC}	-10	+10	-10	+10	μA
V _{CD}	Input Diode Clamp Voltage		Note 3				
I _{OZ}	Output Leakage Current	GND ≤ V _{OUT} ≤ V _{CC} , Output Disabled	-10	+10	-10	+10	μA
I _{OS}	Output Short Circuit Current ^[4]	V _{CC} = Max., V _{OUT} = GND	-20	-90	-20	-90	mA
I _{CC}	V _{CC} Operating Supply Current	V _{CC} = Max., I _{OUT} = 0 mA		120		90	mA
I _{SB}	Standby Supply Current (7C293A Only)	V _{CC} = Max., CS ₁ = V _{IH}		40		30	mA
V _{PP}	Programming Supply Voltage		12	13	12	13	V
I _{PP}	Programming Supply Current			50		50	mA
V _{IHP}	Input HIGH Programming Voltage		3.0		3.0		V
V _{ILP}	Input LOW Programming Voltage			0.4		0.4	V

Notes

- See the last page of this specification for Group A subgroup testing information.
- See the "Introduction to CMOS PROMs" section of the Cypress Data Book for general information on testing.
- For test purposes, not more than one output at a time should be shorted. Short circuit test duration should not exceed 30 seconds.

Electrical Characteristics Over the Operating Range^[2,3] (continued)

Parameter	Description	Test Conditions	7C291AL-35		7C291A-35 7C291A-50		Unit	
			Min.	Max.	Min.	Max.		
V _{OH}	Output HIGH Voltage	V _{CC} = Min., I _{OH} = -4.0 mA	2.4		2.4		V	
V _{OL}	Output LOW Voltage	V _{CC} = Min., I _{OL} = 16.0 mA		0.4		0.4	V	
V _{IH}	Input HIGH Voltage	Guaranteed Input Logical HIGH Voltage for All Inputs	2.0		2.0		V	
V _{IL}	Input LOW Voltage	Guaranteed Input Logical LOW Voltage for All Inputs		0.8		0.8	V	
I _{IX}	Input Load Current	GND ≤ V _{IN} ≤ V _{CC}	-10	+10	-10	+10	μA	
V _{CD}	Input Diode Clamp Voltage		Note 3					
I _{OZ}	Output Leakage Current	GND ≤ V _{OUT} ≤ V _{CC} , Output Disabled	-10	+10	-10	+10	μA	
I _{OS}	Output Short Circuit Current ^[4]	V _{CC} = Max., V _{OUT} = GND	-20	-90	-20	-90	mA	
I _{CC}	V _{CC} Operating Supply Current	V _{CC} = Max., V _{IN} = 2.0V I _{OUT} = 0 mA	Commercial		60		90	mA
			Military				90	
I _{SB}	Standby Supply Current (7C293A Only)	V _{CC} = Max., CS ₁ = V _{IH}	Commercial		30		30	mA
			Military				40	
V _{PP}	Programming Supply Voltage		12	13	12	13	V	
I _{PP}	Programming Supply Current			50		50	mA	
V _{IHP}	Input HIGH Programming Voltage		3.0		3.0		V	
V _{ILP}	Input LOW Programming Voltage			0.4		0.4	V	

Capacitance^[3]

Parameter	Description	Test Conditions	Max.	Unit
C _{IN}	Input Capacitance	T _A = 25°C, f = 1 MHz, V _{CC} = 5.0V	10	pF
C _{OUT}	Output Capacitance		10	pF

AC Test Loads and Waveforms^[3]

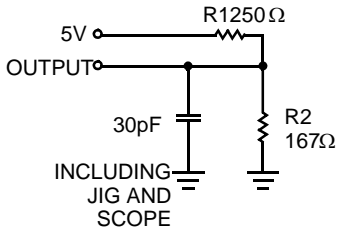

(a) Normal Load

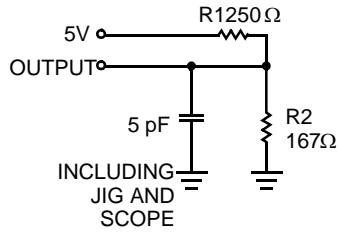

(b) High Z Load

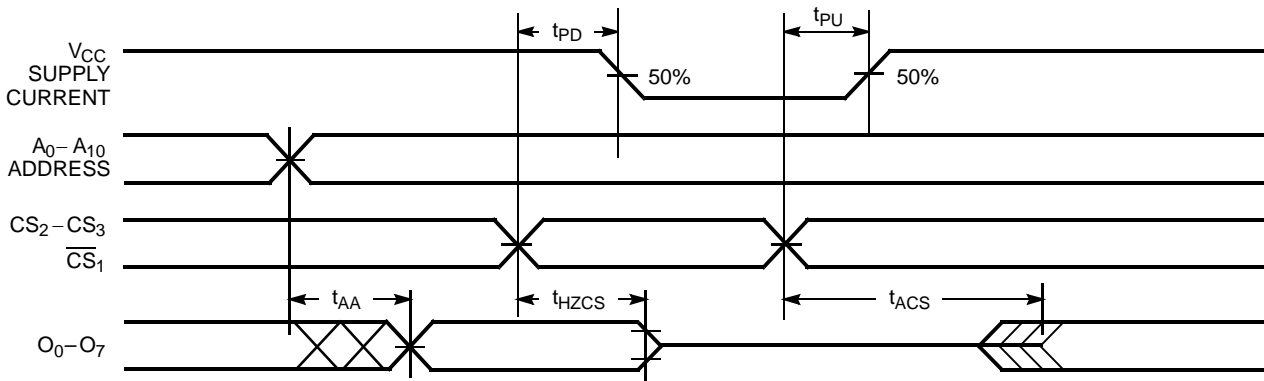
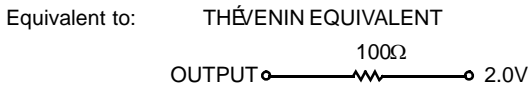
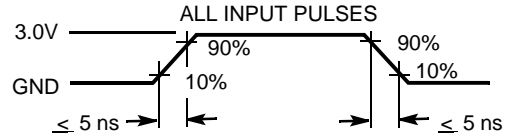

Switching Characteristics Over the Operating Range^[2, 3]

Parameter	Description	7C291A-20		7C291A-25		7C291A-35 7C291AL-35		7C291A-50		Unit
		Min.	Max.	Min.	Max.	Min.	Max.	Min.	Max.	
t _{AA}	Address to Output Valid		20		25		35		50	ns
t _{HZCS1}	Chip Select Inactive to High Z		15		15		20		20	ns
t _{ACS1}	Chip Select Active to Output Valid		15		15		20		20	ns
t _{HZCS2}	Chip Select Inactive to High Z		22		27		35		45	ns
t _{ACS2}	Chip Select Active to Output Valid		22		27		35		45	ns
t _{PU}	Chip Select Active to Power-Up	0		0		0		0		ns
t _{PD}	Chip Select Inactive to Power-Down		22		27		35		45	ns

Erasure Characteristics

Wavelengths of light less than 4000 Angstroms begin to erase these PROMs. For this reason, an opaque label should be placed over the window if the PROM is exposed to sunlight or fluorescent lighting for extended periods of time.

The recommended dose of ultraviolet light for erasure is a wavelength of 2537 Angstroms for a minimum dose (UV intensity x exposure time) of 25 Wsec/cm². For an ultraviolet lamp with a 12 mW/cm² power rating, the exposure time would be approximately 35 minutes.

These PROMs need to be within 1 inch of the lamp during erasure. Permanent damage may result if the PROM is exposed to high-intensity UV light for an extended period of time. 7258 Wsec/cm² is the recommended maximum dosage.

Programming Information

Programming support is available from Cypress as well as from a number of third-party software vendors. For detailed programming information, including a listing of software packages, please see the PROM Programming Information located at the end of this section. Programming algorithms can be obtained from any Cypress representative.

Table 1. Mode Selection

Mode	Pin Function ^[5]					
	Read or Output Disable	A ₁₀ -A ₀	CS ₃	CS ₂	CS ₁	O ₇ -O ₀
	Other	A ₁₀ -A ₀	PGM	VFY	V _{PP}	D ₇ -D ₀
Read		A ₁₀ -A ₀	V _{IH}	V _{IH}	V _{IL}	O ₇ -O ₀
Output Disable ^[6]		A ₁₀ -A ₀	X	X	V _{IH}	High Z
Output Disable		A ₁₀ -A ₀	X	V _{IL}	X	High Z
Output Disable		A ₁₀ -A ₀	V _{IL}	X	X	High Z
Program		A ₁₀ -A ₀	V _{ILP}	V _{IHP}	V _{PP}	D ₇ -D ₀
Program Verify		A ₁₀ -A ₀	V _{IHP}	V _{ILP}	V _{PP}	O ₇ -O ₀
Program Inhibit		A ₁₀ -A ₀	V _{IHP}	V _{IHP}	V _{PP}	High Z
Intelligent Program		A ₁₀ -A ₀	V _{ILP}	V _{IHP}	V _{PP}	D ₇ -D ₀
Blank Check Zeros		A ₁₀ -A ₀	V _{IHP}	V _{ILP}	V _{PP}	Zeros

Figure 1. Programming Pinouts

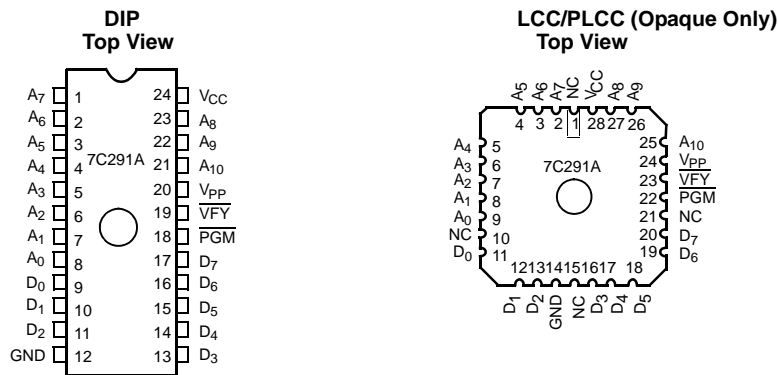

Notes

- 5. X = "don't care" but not to exceed V_{CC} +5%.
- 6. The power-down mode for the CY7C293A is activated by deselecting CS₁.

Typical DC and AC Characteristics

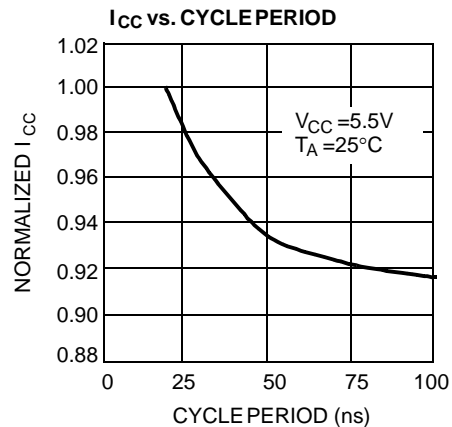
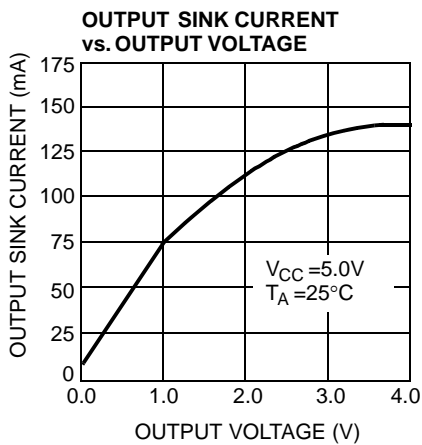
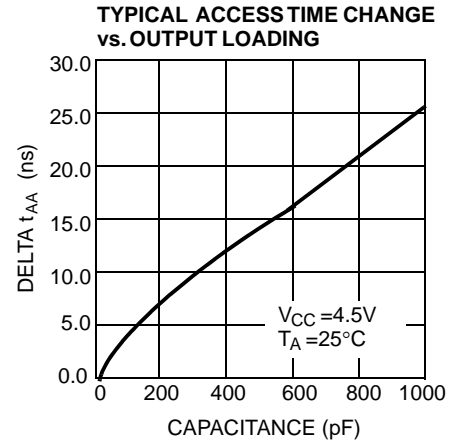
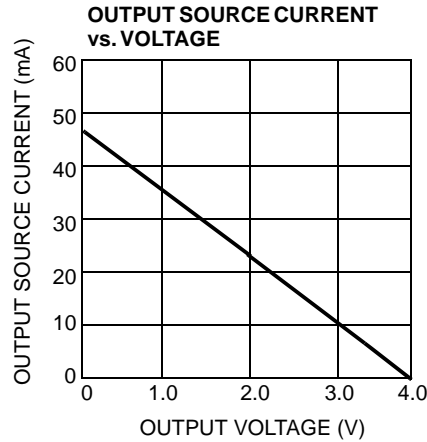
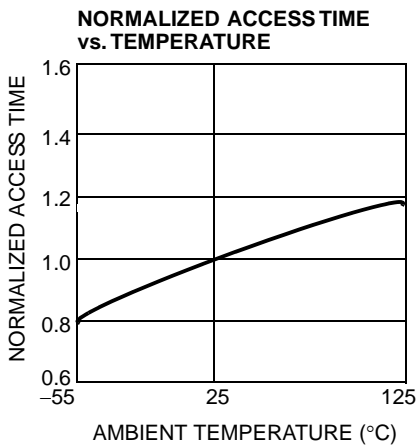
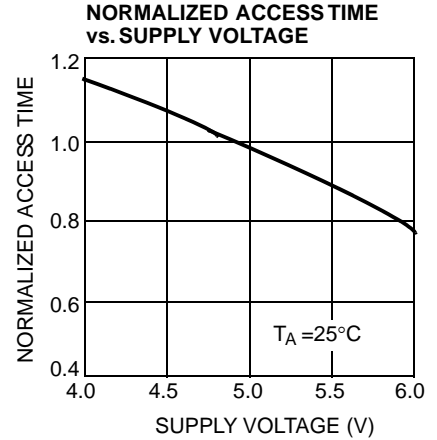
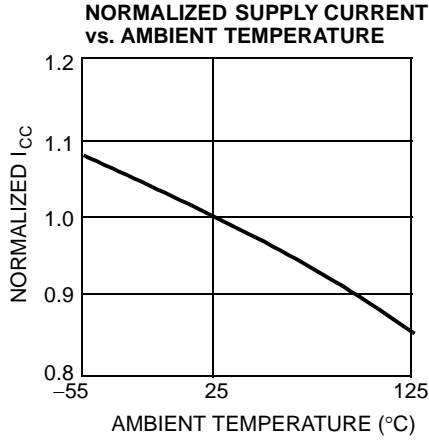
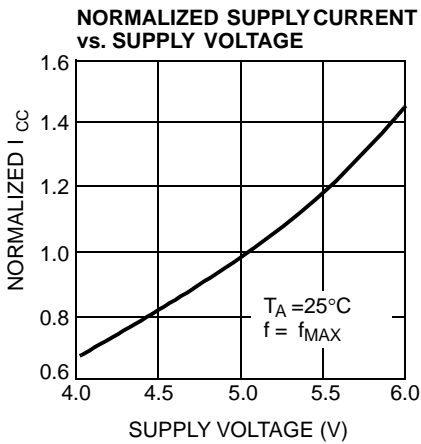

Ordering Information

Speed (ns)	I _{CC} (mA)	Ordering Code	Package Name	Package Type	Operating Range
20	120	CY7C291A-20PC	P13	24-Lead (300-Mil) Molded DIP	Commercial
25	90	CY7C291A-25JC	J64	28-Lead Plastic Leaded Chip Carrier	Commercial
		CY7C291A-25PC	P13	24-Lead (300-Mil) Molded DIP	
35	60	CY7C291AL-35JC	J64	28-Lead Plastic Leaded Chip Carrier	Commercial
		CY7C291AL-35PC	P13	24-Lead (300-Mil) Molded DIP	
		CY7C291AL-35WC	W14	24-Lead (300-Mil) Windowed CerDIP	
	90	CY7C291A-35JC	J64	28-Lead Plastic Leaded Chip Carrier	Commercial
		CY7C291A-35PC	P13	24-Lead (300-Mil) Molded DIP	
		CY7C291A-35WC	W14	24-Lead (300-Mil) Windowed CerDIP	
120	CY7C291A-35DMB	D14	24-Lead (300-Mil) CerDIP	Military	
50	90	CY7C291A-50PC	P13	24-Lead (300-Mil) Molded DIP	Commercial
		CY7C291A-50WMB	W14	24-Lead (300-Mil) Windowed CerDIP	Military

MILITARY SPECIFICATIONS
Group A Subgroup Testing

DC Characteristics

Parameter	Subgroups
V _{OH}	1, 2, 3
V _{OL}	1, 2, 3
V _{IH}	1, 2, 3
V _{IL}	1, 2, 3
I _{IX}	1, 2, 3
I _{OZ}	1, 2, 3
I _{CC}	1, 2, 3
I _{SB}	1, 2, 3

SMD Cross Reference

SMD Number	Suffix	Cypress Number
5962-87650	01LX	CY7C291-50WMB
5962-87650	03LX	CY7C291-35WMB
5962-88734	023X	CY7C291A-35LMB
5962-88734	033X	CY7C291A-35LMB
5962-88734	04LX	CY7C291A-25DMB
5962-88734	043X	CY7C291A-25LMB

Switching Characteristics

Parameter	Subgroups
t _{AA}	7, 8, 9, 10, 11
t _{ACS1}	7, 8, 9, 10, 11

Package Diagrams

Figure 2. 24-Lead (300-Mil) CerDIP D14

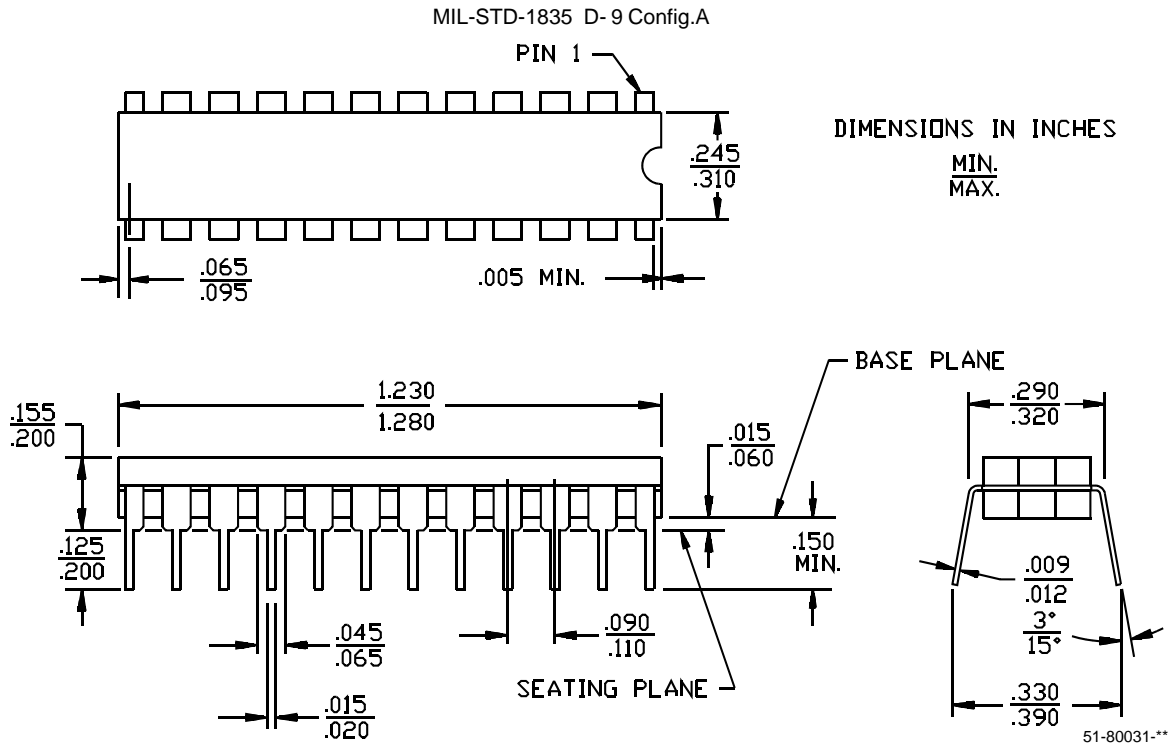
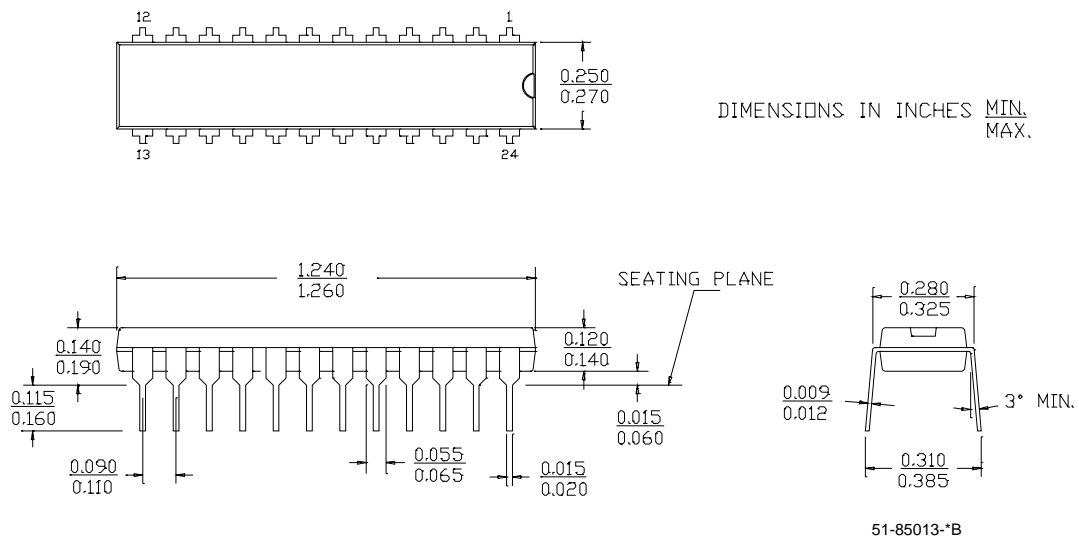
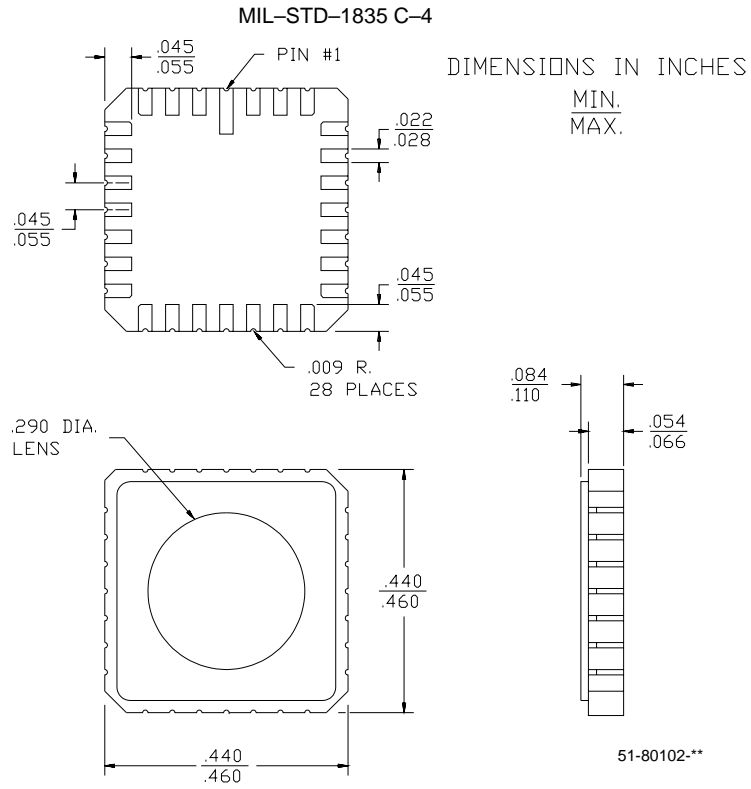

Figure 3. 24-Lead (300-Mil) PDIP P13



Package Diagrams (continued)

Figure 4. 28-Pin Windowed Leadless Chip Carrier Q64



Package Diagrams (continued)

Figure 5. 24 Lead (300 Mil) SOIC - S13

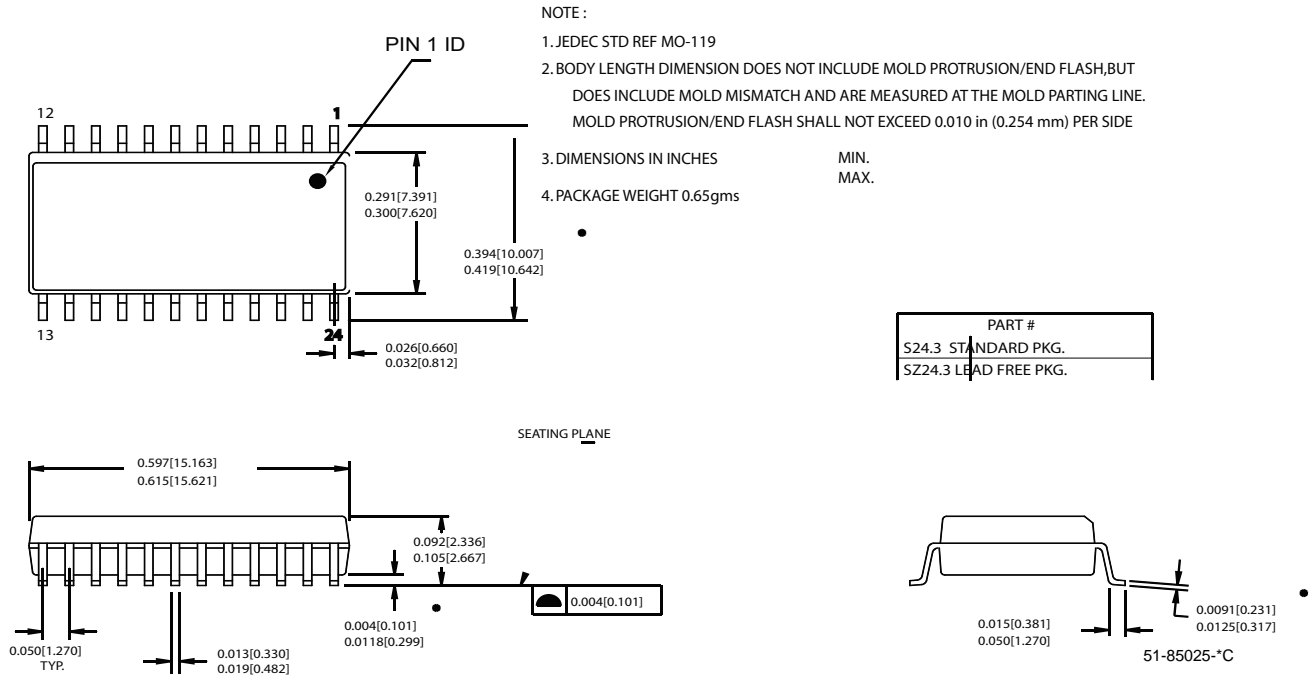

Package Diagrams (continued)

Figure 6. 24-Lead (300-Mil) Windowed CerDIP W14

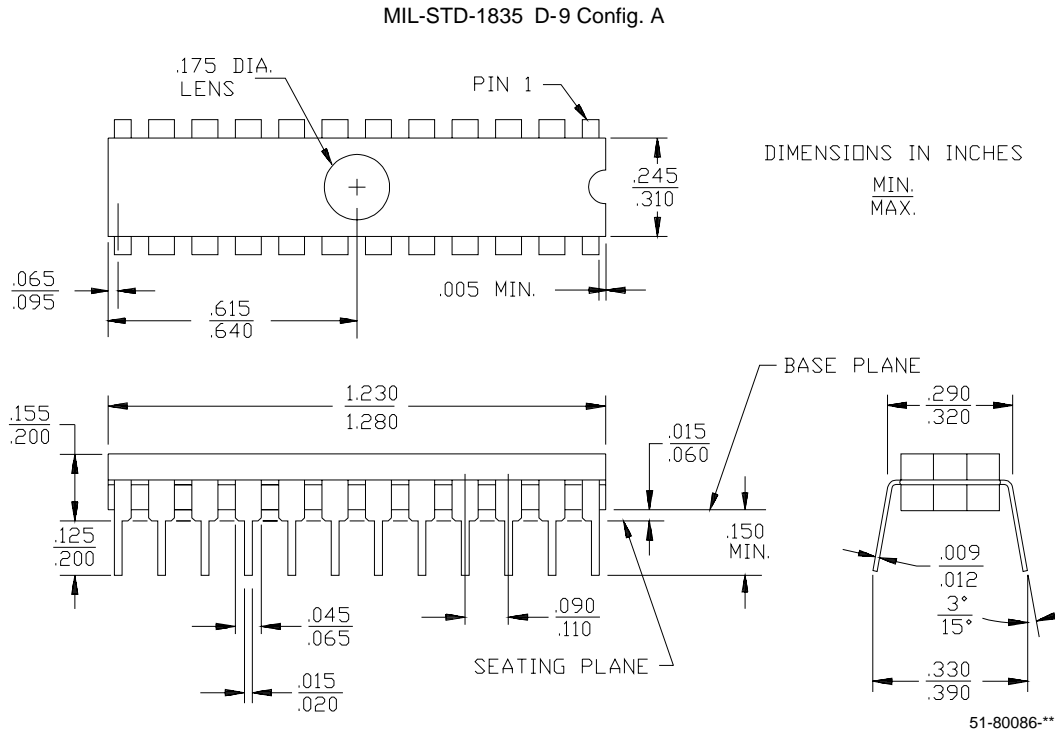

All product and company names mentioned in this document may be the trademarks of their respective holders.

Document History Page

Document Title: CY7C291A 2K x 8 Reprogrammable PROM
Document Number: 38-04011

REV.	ECN NO.	Issue Date	Orig. of Change	Description of Change
**	114138	03/18/02	DSG	Changed from Spec number: 38-00075 to 38-04011
*A	118905	10/11/02	GBI	Updated ordering information
*B	499562	See ECN	PCI	Updated ordering information