

## Features

- Temperature ranges
  - $-40^{\circ}\text{C}$  to  $85^{\circ}\text{C}$
- Pin and function compatible with CY7C199C
- High speed
  - $t_{AA} = 10\text{ ns}$
- Low active power
  - $I_{CC} = 80\text{ mA}$  at  $10\text{ ns}$
- Low CMOS standby power
  - $I_{SB2} = 3\text{ mA}$
- 2.0 V data retention
- Automatic power-down when deselected
- Complementary metal oxide semiconductor (CMOS) for optimum speed/power
- Transistor-transistor logic (TTL) compatible inputs and outputs
- Easy memory expansion with  $\overline{\text{CE}}$  and  $\overline{\text{OE}}$  features
- Available in Pb-free 28-pin 300-Mil-wide molded small outline J-lead package (SOJ) and 28-pin thin small outline package (TSOP) I packages

## Logic Block Diagram

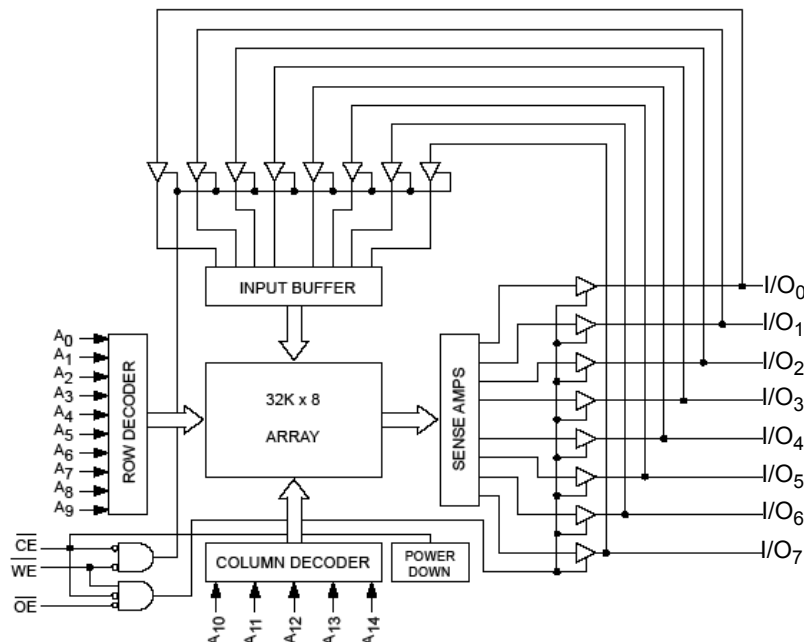

## Functional Description

The CY7C199D is a high performance CMOS static RAM organized as 32,768 words by 8-bits. Easy memory expansion is provided by an active LOW chip enable ( $\overline{\text{CE}}$ ), an active LOW output enable ( $\overline{\text{OE}}$ ) and tri-state drivers. This device has an automatic power-down feature, reducing the power consumption when deselected. The input and output pins ( $I/O_0$  through  $I/O_7$ ) are placed in a high impedance state when the device is deselected ( $\overline{\text{CE}}$  HIGH), the outputs are disabled ( $\overline{\text{OE}}$  HIGH), or during a write operation ( $\overline{\text{CE}}$  LOW and  $\overline{\text{WE}}$  LOW).

Write to the device by taking chip enable ( $\overline{\text{CE}}$ ) and write enable ( $\overline{\text{WE}}$ ) inputs LOW. Data on the eight I/O pins ( $I/O_0$  through  $I/O_7$ ) is then written into the location specified on the address pins ( $A_0$  through  $A_{14}$ ).

Read from the device by taking chip enable ( $\overline{\text{CE}}$ ) and output enable ( $\overline{\text{OE}}$ ) LOW while forcing write enable ( $\overline{\text{WE}}$ ) HIGH. Under these conditions, the contents of the memory location specified by the address pins appears on the I/O pins.

## Contents

<b>Pin Configuration</b> .....	<b>3</b>	<b>Ordering Information</b> .....	<b>9</b>
<b>Selection Guide</b> .....	<b>3</b>	Ordering Code Definitions .....	9
<b>Maximum Ratings</b> .....	<b>4</b>	<b>Package Diagrams</b> .....	<b>10</b>
<b>Operating Range</b> .....	<b>4</b>	<b>Acronyms</b> .....	<b>12</b>
<b>Electrical Characteristics</b> .....	<b>4</b>	<b>Document Conventions</b> .....	<b>12</b>
<b>Capacitance</b> .....	<b>5</b>	Units of Measure .....	12
<b>Thermal Resistance</b> .....	<b>5</b>	<b>Document History Page</b> .....	<b>13</b>
<b>AC Test Loads and Waveforms</b> .....	<b>5</b>	<b>Sales, Solutions, and Legal Information</b> .....	<b>14</b>
<b>Switching Characteristics</b> .....	<b>6</b>	Worldwide Sales and Design Support .....	14
<b>Data Retention Characteristics</b> .....	<b>7</b>	Products .....	14
<b>Data Retention Waveform</b> .....	<b>7</b>	PSoC Solutions .....	14
<b>Switching Waveforms</b> .....	<b>7</b>		
<b>Truth Table</b> .....	<b>9</b>		

## Pin Configuration

Figure 1. 28-pin SOJ (Top View)

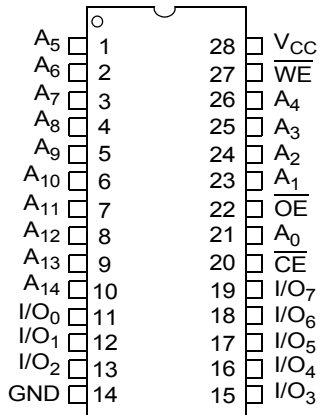
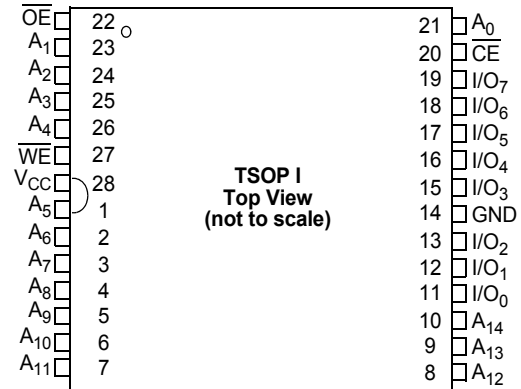

Figure 2. 28-pin TSOP I (Top View)



## Selection Guide

Description	-10 (Industrial)	Unit
Maximum access time	10	ns
Maximum operating current	80	mA
Maximum CMOS standby current	3	mA

**Maximum Ratings**

Exceeding the maximum ratings may impair the useful life of the device. These user guidelines are not tested.

- Storage temperature ..... -65 °C to +150 °C
- Ambient temperature with power applied ..... -55 °C to +125 °C
- Supply voltage on V<sub>CC</sub> to relative GND <sup>[1]</sup> ..... -0.5 V to +6.0 V
- DC voltage applied to outputs in high Z State <sup>[1]</sup> ..... -0.5 V to V<sub>CC</sub> + 0.5 V

- DC input voltage <sup>[1]</sup> ..... -0.5 V to V<sub>CC</sub> + 0.5 V
- Output current into outputs (LOW) ..... 20 mA
- Static discharge voltage ..... > 2,001 V (per MIL-STD-883, method 3015)
- Latch-up current ..... > 140 mA

**Operating Range**

Range	Ambient Temperature	V <sub>CC</sub>	Speed
Industrial	-40 °C to +85 °C	5 V ± 0.5 V	10 ns

**Electrical Characteristics**

Over the operating range

Parameter	Description	Test Conditions	CY7C199D-10		Unit	
			Min	Max		
V <sub>OH</sub>	Output HIGH voltage	I <sub>OH</sub> = -4.0 mA	2.4	-	V	
V <sub>OL</sub>	Output LOW voltage	I <sub>OL</sub> = 8.0 mA	-	0.4	V	
V <sub>IH</sub>	Input HIGH voltage <sup>[1]</sup>		2.2	V <sub>CC</sub> + 0.5	V	
V <sub>IL</sub>	Input LOW voltage <sup>[1]</sup>		-0.5	0.8	V	
I <sub>IX</sub>	Input leakage current	GND ≤ V <sub>I</sub> ≤ V <sub>CC</sub>	-1	+1	μA	
I <sub>OZ</sub>	Output leakage current	GND ≤ V <sub>O</sub> ≤ V <sub>CC</sub> , output disabled	-1	+1	μA	
I <sub>CC</sub>	V <sub>CC</sub> operating supply current	V <sub>CC</sub> = V <sub>CC(max)</sub> , I <sub>OUT</sub> = 0 mA, f = f <sub>max</sub> = 1/t <sub>RC</sub>	100 MHz	-	80	mA
			83 MHz	-	72	mA
			66 MHz	-	58	mA
			40 MHz	-	37	mA
I <sub>SB1</sub>	Automatic CE power-down current— TTL Inputs	V <sub>CC</sub> = V <sub>CC(max)</sub> , $\overline{CE} \geq V_{IH}$ , V <sub>IN</sub> ≥ V <sub>IH</sub> or V <sub>IN</sub> ≤ V <sub>IL</sub> , f = f <sub>max</sub>	-	10	mA	
I <sub>SB2</sub>	Automatic CE power-down current— CMOS Inputs	V <sub>CC</sub> = V <sub>CC(max)</sub> , $\overline{CE} \geq V_{CC} - 0.3 V$ , V <sub>IN</sub> ≥ V <sub>CC</sub> - 0.3 V or V <sub>IN</sub> ≤ 0.3 V, f = 0	-	3	mA	

**Note**

1. V<sub>IL(min)</sub> = -2.0 V and V<sub>IH(max)</sub> = V<sub>CC</sub> + 1 V for pulse durations of less than 5 ns.

### Capacitance

Parameter [2]	Description	Test Conditions	Max	Unit
C <sub>IN</sub>	Input capacitance	T <sub>A</sub> = 25 °C, f = 1 MHz, V <sub>CC</sub> = 5.0 V	8	pF
C <sub>OUT</sub>	Output capacitance		8	pF

### Thermal Resistance

Parameter [2]	Description	Test Conditions	28-pin SOJ	28-pin TSOP I	Unit
Θ <sub>JA</sub>	Thermal resistance (junction to ambient)	Still air, soldered on a 3 × 4.5 inch, four-layer printed circuit board	59.16	54.65	°C/W
Θ <sub>JC</sub>	Thermal resistance (junction to case)		40.84	21.49	°C/W

### AC Test Loads and Waveforms

Figure 3. AC Test Loads and Waveforms [3]

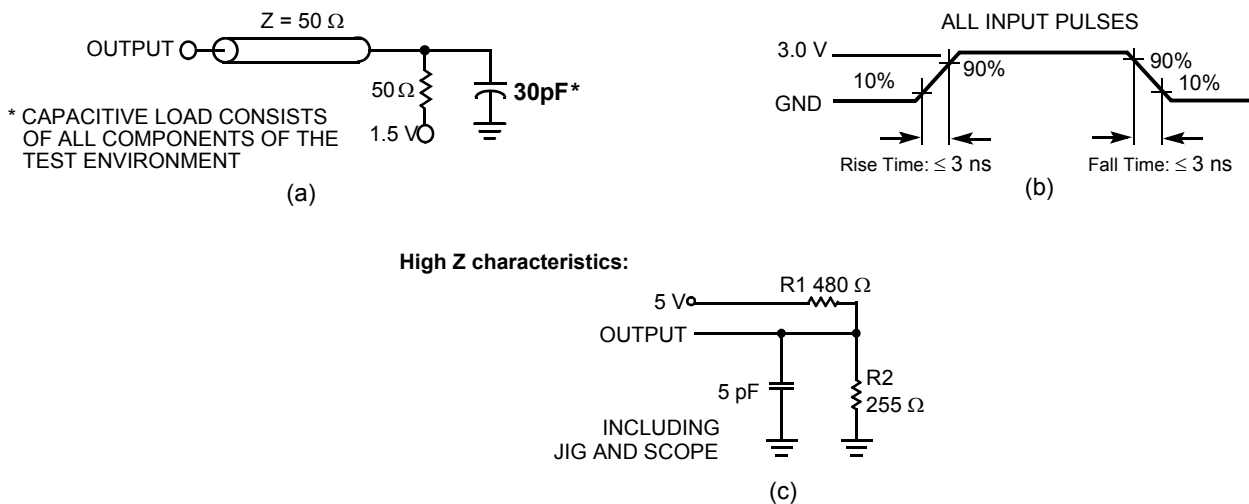

**Notes**

2. Tested initially and after any design or process changes that may affect these parameters.
3. AC characteristics (except high Z) are tested using the load conditions shown in Figure 3 (a). High Z characteristics are tested for all speeds using the test load shown in Figure 3 (c).

## Switching Characteristics

Over the operating range

Parameter <sup>[4]</sup>	Description	CY7C199D-10		Unit
		Min	Max	
<b>Read Cycle</b>				
$t_{power}^{[5]}$	$V_{CC(ypical)}$ to the first access	100	–	$\mu s$
$t_{RC}$	Read cycle time	10	–	ns
$t_{AA}$	Address to data valid	–	10	ns
$t_{OHA}$	Data hold from address change	3	–	ns
$t_{ACE}$	$\overline{CE}$ LOW to data valid	–	10	ns
$t_{DOE}$	$\overline{OE}$ LOW to data valid	–	5	ns
$t_{LZOE}^{[6]}$	$\overline{OE}$ LOW to low Z	0	–	ns
$t_{HZOE}^{[6, 7]}$	$\overline{OE}$ HIGH to high Z	–	5	ns
$t_{LZCE}^{[6]}$	$\overline{CE}$ LOW to low Z	3	–	ns
$t_{HZCE}^{[6, 7]}$	$\overline{CE}$ HIGH to high Z	–	5	ns
$t_{PU}^{[8]}$	$\overline{CE}$ LOW to power-up	0	–	ns
$t_{PD}^{[8]}$	$\overline{CE}$ HIGH to power-down	–	10	ns
<b>Write Cycle <sup>[9, 10]</sup></b>				
$t_{WC}$	Write cycle time	10	–	ns
$t_{SCE}$	$\overline{CE}$ LOW to write end	7	–	ns
$t_{AW}$	Address setup to write end	7	–	ns
$t_{HA}$	Address hold from write end	0	–	ns
$t_{SA}$	Address setup to write start	0	–	ns
$t_{PWE}$	$\overline{WE}$ pulse width	7	–	ns
$t_{SD}$	Data setup to write end	6	–	ns
$t_{HD}$	Data hold from write end	0	–	ns
$t_{HZWE}^{[6]}$	$\overline{WE}$ LOW to high Z	–	5	ns
$t_{LZWE}^{[6, 7]}$	$\overline{WE}$ HIGH to low Z	3	–	ns

### Notes

- Test conditions assume signal transition time of 3 ns or less for all speeds, timing reference levels of 1.5 V, input pulse levels of 0 to 3.0 V, and output loading of the specified  $I_{OL}/I_{OH}$  and 30-pF load capacitance.
- $t_{POWER}$  gives the minimum amount of time that the power supply should be at typical  $V_{CC}$  values until the first memory access can be performed.
- At any given temperature and voltage condition,  $t_{HZCE}$  is less than  $t_{LZCE}$ ,  $t_{HZOE}$  is less than  $t_{LZOE}$ , and  $t_{HZWE}$  is less than  $t_{LZWE}$  for any given device.
- $t_{HZOE}$ ,  $t_{HZCE}$ , and  $t_{HZWE}$  are specified with  $C_L = 5$  pF as in part (b) of [Figure 3 on page 5](#). Transition is measured  $\pm 200$  mV from steady-state voltage.
- This parameter is guaranteed by design and is not tested.
- The internal write time of the memory is defined by the overlap of  $\overline{CE}$  LOW and  $\overline{WE}$  LOW. Both signals must be LOW to initiate a write and either signal can terminate a write by going HIGH. The data input setup and hold timing should be referenced to the rising edge of the signal that terminates the write.
- The minimum write cycle time for Write Cycle No. 3 ( $\overline{WE}$  controlled,  $\overline{OE}$  LOW) is the sum of  $t_{HZWE}$  and  $t_{SD}$ .

### Data Retention Characteristics

Over the operating range

Parameter	Description	Conditions	Min	Max	Unit
$V_{DR}$	$V_{CC}$ for data retention		2.0	–	V
$I_{CCDR}$	Data retention current	$V_{CC} = V_{DR} = 2.0\text{ V}$ , $\overline{CE} \geq V_{CC} - 0.3\text{ V}$ , $V_{IN} \geq V_{CC} - 0.3\text{ V}$ or $V_{IN} \leq 0.3\text{ V}$	–	3	mA
$t_{CDR}^{[11]}$	Chip deselect to data retention time		0	–	ns
$t_R^{[12]}$	Operation recovery time		15	–	ns

### Data Retention Waveform

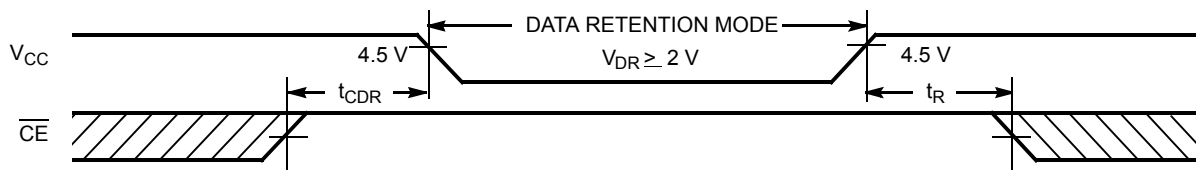

### Switching Waveforms

Figure 4. Read Cycle No. 1: Address Transition Controlled [13, 14]

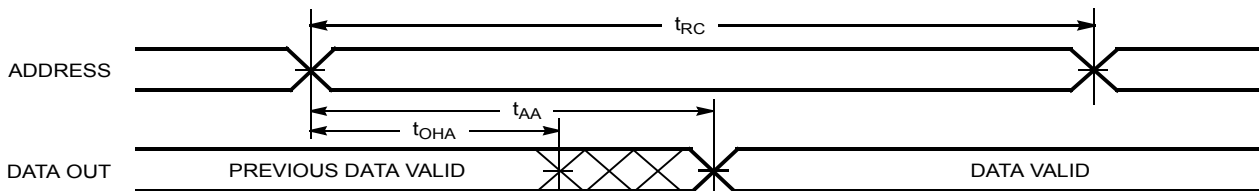
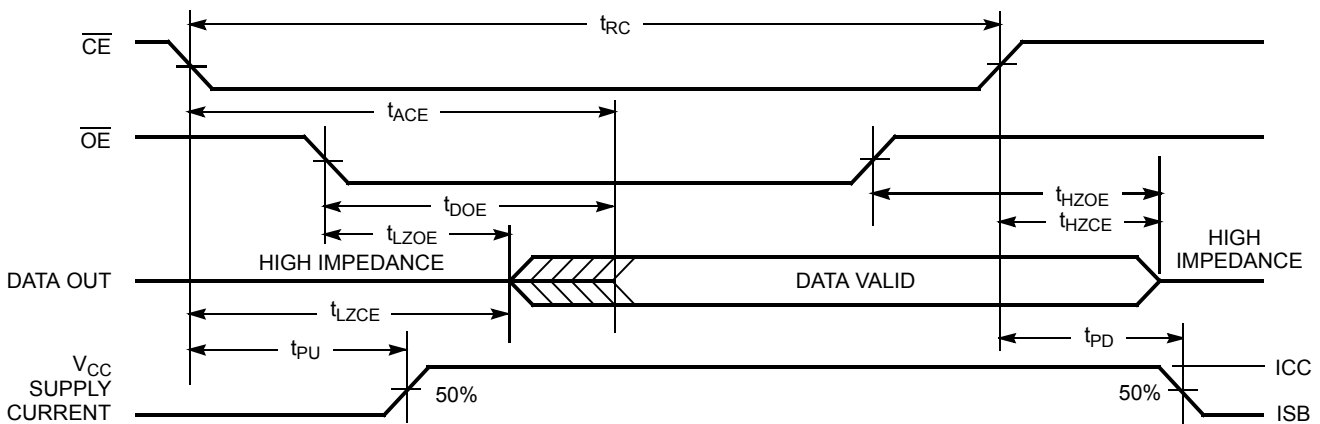

Figure 5. Read Cycle No. 2  $\overline{OE}$  Controlled [14, 15]



**Notes**

- 11. Tested initially and after any design or process changes that may affect these parameters.
- 12. Full device operation requires linear  $V_{CC}$  ramp from  $V_{DR}$  to  $V_{CC(min)}$   $\geq 50\ \mu\text{s}$  or stable at  $V_{CC(min)} \geq 50\ \mu\text{s}$ .
- 13. Device is continuously selected.  $OE, CE = V_{IL}$ .
- 14.  $WE$  is HIGH for read cycle.
- 15. Address valid prior to or coincident with  $\overline{CE}$  transition LOW.

Switching Waveforms (continued)

Figure 6. Write Cycle No. 1:  $\overline{\text{CE}}$  Controlled [16, 17, 18]

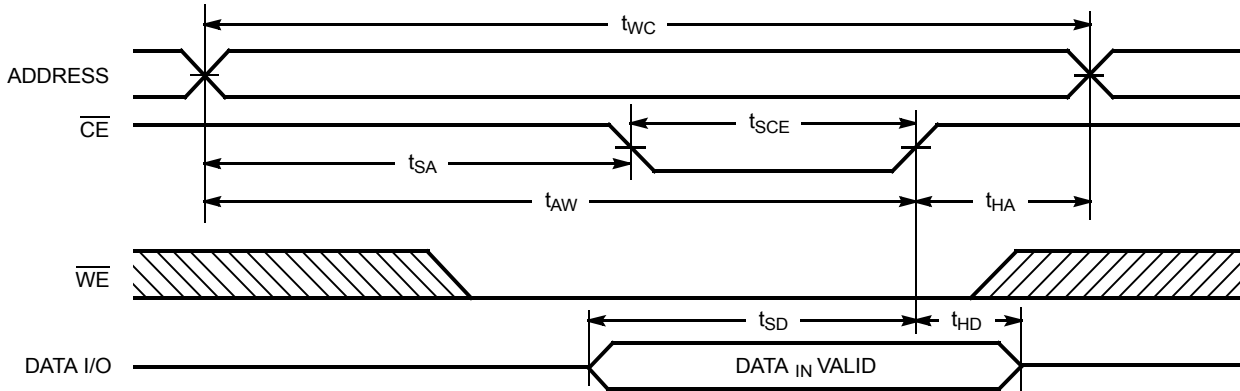
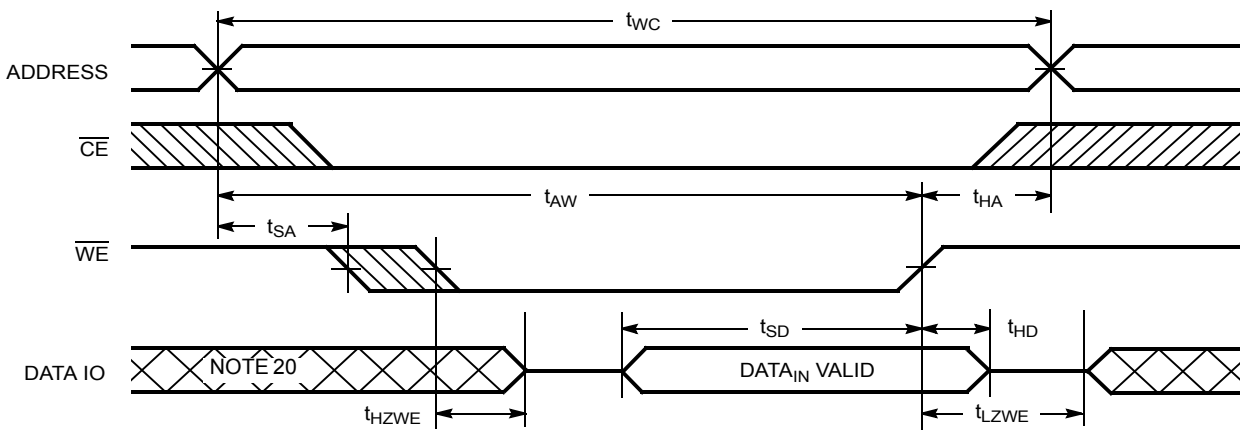

Figure 7. Write Cycle No. 3  $\overline{\text{WE}}$  Controlled,  $\overline{\text{OE}}$  LOW [18, 19]



Notes

- 16. The internal write time of the memory is defined by the overlap of  $\overline{\text{CE}}$  LOW and  $\overline{\text{WE}}$  LOW. Both signals must be LOW to initiate a write and either signal can terminate a write by going HIGH. The data input setup and hold timing should be referenced to the rising edge of the signal that terminates the write.
- 17. Data I/O is high impedance if  $\overline{\text{OE}} = V_{IH}$ .
- 18. If  $\overline{\text{CE}}$  goes HIGH simultaneously with  $\overline{\text{WE}}$  HIGH, the output remains in a high-impedance state.
- 19. The minimum write cycle time for Write Cycle No. 3 ( $\overline{\text{WE}}$  controlled,  $\overline{\text{OE}}$  LOW) is the sum of  $t_{HZWE}$  and  $t_{SD}$ .
- 20. During this period the I/Os are in the output state and input signals should not be applied.



### Truth Table

$\overline{CE}$	$\overline{WE}$	$\overline{OE}$	Inputs/Outputs	Mode	Power
H	X	X	High Z	Deselect/power-down	Standby ( $I_{SB}$ )
L	H	L	Data out	Read	Active ( $I_{CC}$ )
L	L	X	Data in	Write	Active ( $I_{CC}$ )
L	H	H	High Z	Deselect, output disabled	Active ( $I_{CC}$ )

### Ordering Information

Cypress offers other versions of this type of product in many different configurations and features. The following table contains only the list of parts that are currently available. For a complete listing of all options, visit the Cypress website at <http://www.cypress.com> and refer to the product summary page at <http://www.cypress.com/products> or contact your local sales representative.

Cypress maintains a worldwide network of offices, solution centers, manufacturer's representatives and distributors. To find the office closest to you, visit us at <http://www.cypress.com/go/datasheet/offices>.

Speed (ns)	Ordering Code	Package Diagram	Package Type	Operating Range
10	CY7C199D-10VXI	51-85031	28-pin (300-Mil) Molded SOJ (Pb-free)	Industrial
	CY7C199D-10ZXI	51-85071	28-pin TSOP Type I (Pb-free)	

Please contact your local Cypress sales representative for availability of these parts.

### Ordering Code Definitions

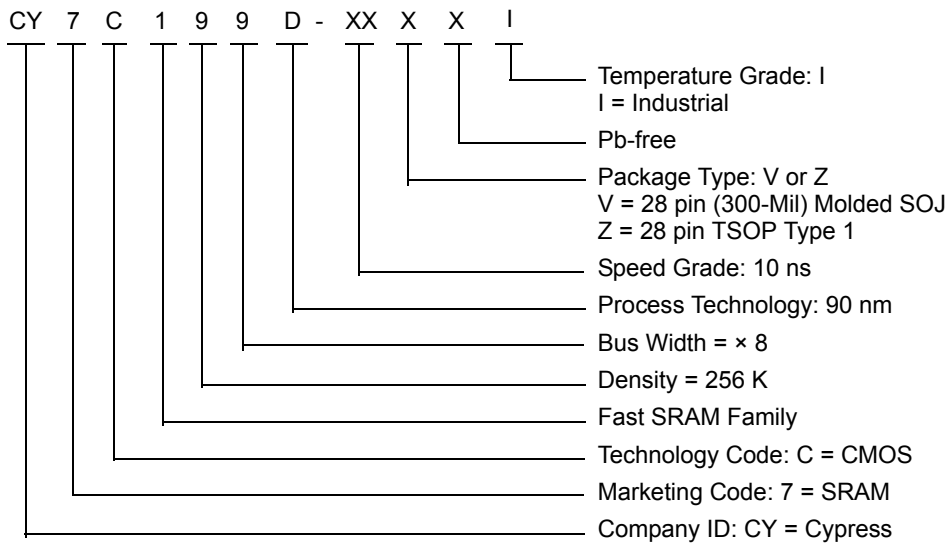

Package Diagrams

Figure 8. 28-pin SOJ 300-Mils V28.3 (Molded SOJ V21)

NOTE :

1. JEDEC STD REF M0088
2. BODY LENGTH DIMENSION DOES NOT INCLUDE MOLD PROTRUSION/END FLASH  
MOLD PROTRUSION/END FLASH SHALL NOT EXCEED 0.006 in (0.152 mm) PER SIDE
3. DIMENSIONS IN INCHES MIN.  
MAX.

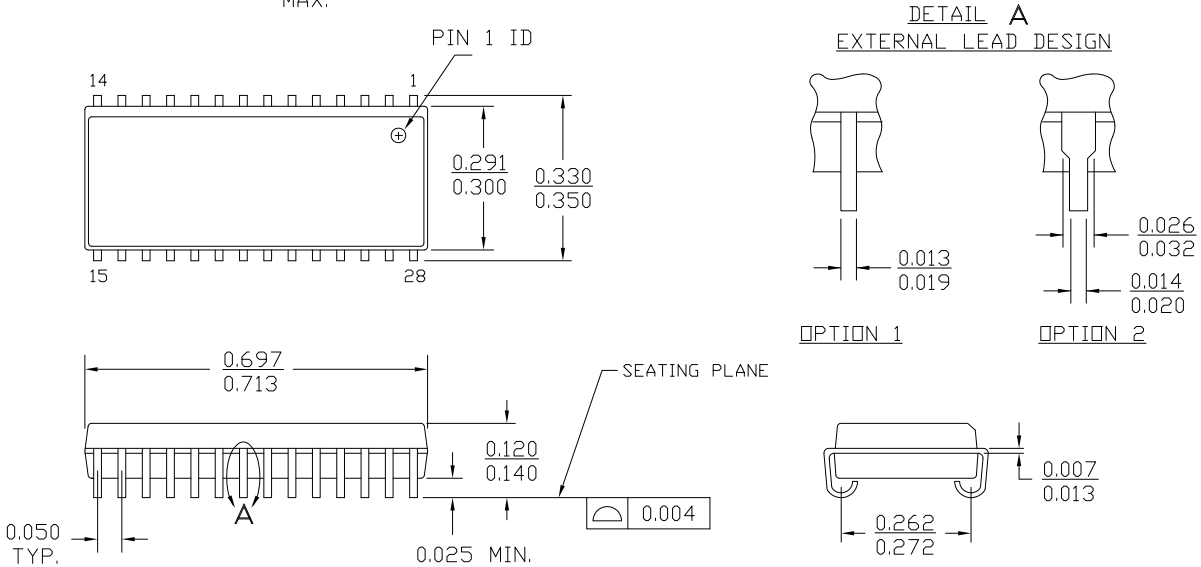

51-85031 \*D

Package Diagrams (continued)

Figure 9. 28-pin TSOP Type 1 (8 × 13.4 × 1.2 mm) Z28 (Standard)

NOTE: ORIENTATION I.D. MAY BE LOCATED EITHER AS SHOWN IN OPTION 1 OR OPTION 2

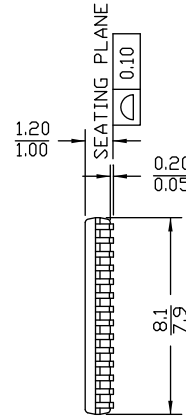
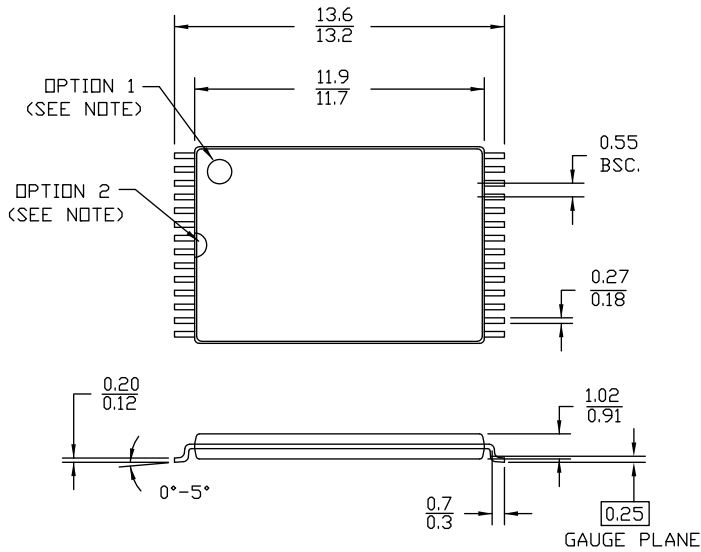

DIMENSION IN MM  
 MAX.  
 MIN.

51-85071 \*1

## Acronyms

Acronym	Description
$\overline{CE}$	chip enable
CMOS	complementary metal oxide semiconductor
I/O	input/output
$\overline{OE}$	output enable
SOJ	small outline J-lead
SRAM	static random access memory
TSOP	thin small outline package
TTL	transistor-transistor logic
$\overline{WE}$	write enable

## Document Conventions

### Units of Measure

Symbol	Unit of Measure
$^{\circ}\text{C}$	degree Celsius
$\mu\text{A}$	micro Amperes
$\mu\text{s}$	micro seconds
$\text{mA}$	milli Amperes
$\text{mm}$	milli meter
$\text{ns}$	nano seconds
$\text{pF}$	pico Farad
V	Volts
W	Watts

**Document History Page**

Document Title: CY7C199D, 256 K (32 K × 8) Static RAM Document Number: 38-05471				
Revision	ECN	Orig. of Change	Submission Date	Description of Change
**	201560	SWI	See ECN	Advance Information datasheet for C9 IPP
*A	233728	RKF	See ECN	DC parameters modified as per EROS (Spec # 01-02165) Pb-free Offering in Ordering Information
*B	262950	RKF	See ECN	Removed 28-LCC Pinout and Package Diagrams Added Data Retention Characteristics table Added T <sub>power</sub> Spec in Switching Characteristics table Shaded Ordering Information
*C	307594	RKF	See ECN	Reduced Speed bins to -10, -12 and -15 ns
*D	820660	VKN	See ECN	Converted from Preliminary to Final Removed 12 ns and 15 ns speed bin Removed Commercial Operating range Removed "L" part Removed 28-pin PDIP and 28-pin SOIC package Changed Overshoot spec from V <sub>CC</sub> +2V to V <sub>CC</sub> +1V in footnote #2 Changed I <sub>CC</sub> spec from 60 mA to 80 mA for 100 MHz speed bin Added I <sub>CC</sub> specs for 83 MHz, 66 MHz and 40 MHz speed bins Updated Thermal Resistance table Updated Ordering Information Table
*E	2745093	VKN	See ECN	Included 28-Pin SOIC package Changed V <sub>IH</sub> level from 2.0V to 2.2V For Industrial grade, changed t <sub>SD</sub> from 5 ns to 6 ns, and t <sub>HZWE</sub> from 6 ns to 5 ns Included Automotive-E information
*F	2897087	AJU	03/22/10	Removed obsolete parts from ordering information table Updated package diagrams
*G	3023234	RAME	09/06/2010	Added Auto-E SOIC package related info Changed TDOE spec from 10 ns to 11 ns in CY7C199D-25. Added <a href="#">Ordering Code Definitions</a> . Added <a href="#">Acronyms</a> and <a href="#">Document Conventions</a> .
*H	3130763	PRAS	01/07/11	Dislodged Automotive information to a new datasheet (001-65530)
*I	3271782	PRAS	06/02/2011	Updated <a href="#">Functional Description</a> (Removed "For best practice recommendations, refer to the Cypress application note AN1064, SRAM System Guidelines."). Updated <a href="#">Package Diagrams</a> . Updated in new template.

## Sales, Solutions, and Legal Information

### Worldwide Sales and Design Support

Cypress maintains a worldwide network of offices, solution centers, manufacturer's representatives, and distributors. To find the office closest to you, visit us at [Cypress Locations](#).

### Products

<a href="#">Automotive</a>	<a href="http://cypress.com/go/automotive">cypress.com/go/automotive</a>
<a href="#">Clocks &amp; Buffers</a>	<a href="http://cypress.com/go/clocks">cypress.com/go/clocks</a>
<a href="#">Interface</a>	<a href="http://cypress.com/go/interface">cypress.com/go/interface</a>
<a href="#">Lighting &amp; Power Control</a>	<a href="http://cypress.com/go/powerpsoc">cypress.com/go/powerpsoc</a> <a href="http://cypress.com/go/plc">cypress.com/go/plc</a>
<a href="#">Memory</a>	<a href="http://cypress.com/go/memory">cypress.com/go/memory</a>
<a href="#">Optical &amp; Image Sensing</a>	<a href="http://cypress.com/go/image">cypress.com/go/image</a>
<a href="#">PSoC</a>	<a href="http://cypress.com/go/psoc">cypress.com/go/psoc</a>
<a href="#">Touch Sensing</a>	<a href="http://cypress.com/go/touch">cypress.com/go/touch</a>
<a href="#">USB Controllers</a>	<a href="http://cypress.com/go/USB">cypress.com/go/USB</a>
<a href="#">Wireless/RF</a>	<a href="http://cypress.com/go/wireless">cypress.com/go/wireless</a>

### PSoC Solutions

[psoc.cypress.com/solutions](http://psoc.cypress.com/solutions)  
PSoC 1 | PSoC 3 | PSoC 5

---

© Cypress Semiconductor Corporation, 2004-2011. The information contained herein is subject to change without notice. Cypress Semiconductor Corporation assumes no responsibility for the use of any circuitry other than circuitry embodied in a Cypress product. Nor does it convey or imply any license under patent or other rights. Cypress products are not warranted nor intended to be used for medical, life support, life saving, critical control or safety applications, unless pursuant to an express written agreement with Cypress. Furthermore, Cypress does not authorize its products for use as critical components in life-support systems where a malfunction or failure may reasonably be expected to result in significant injury to the user. The inclusion of Cypress products in life-support systems application implies that the manufacturer assumes all risk of such use and in doing so indemnifies Cypress against all charges.

Any Source Code (software and/or firmware) is owned by Cypress Semiconductor Corporation (Cypress) and is protected by and subject to worldwide patent protection (United States and foreign), United States copyright laws and international treaty provisions. Cypress hereby grants to licensee a personal, non-exclusive, non-transferable license to copy, use, modify, create derivative works of, and compile the Cypress Source Code and derivative works for the sole purpose of creating custom software and or firmware in support of licensee product to be used only in conjunction with a Cypress integrated circuit as specified in the applicable agreement. Any reproduction, modification, translation, compilation, or representation of this Source Code except as specified above is prohibited without the express written permission of Cypress.

Disclaimer: CYPRESS MAKES NO WARRANTY OF ANY KIND, EXPRESS OR IMPLIED, WITH REGARD TO THIS MATERIAL, INCLUDING, BUT NOT LIMITED TO, THE IMPLIED WARRANTIES OF MERCHANTABILITY AND FITNESS FOR A PARTICULAR PURPOSE. Cypress reserves the right to make changes without further notice to the materials described herein. Cypress does not assume any liability arising out of the application or use of any product or circuit described herein. Cypress does not authorize its products for use as critical components in life-support systems where a malfunction or failure may reasonably be expected to result in significant injury to the user. The inclusion of Cypress' product in a life-support systems application implies that the manufacturer assumes all risk of such use and in doing so indemnifies Cypress against all charges.

Use may be limited by and subject to the applicable Cypress software license agreement.