

256Kx1 Static RAM

Features

- High speed
 - 12 ns
- CMOS for optimum speed/power
- Low active power
 - 880 mW
- Low standby power
 - 220 mW
- TTL-compatible inputs and outputs
- Automatic power-down when deselected

Functional Description

The CY7C197 is a high-performance CMOS static RAM organized as 256K words by 1 bit. Easy memory expansion is pro-

vided by an active LOW Chip Enable (\overline{CE}) and three-state drivers. The CY7C197 has an automatic power-down feature, reducing the power consumption by 75% when deselected.

Writing to the device is accomplished when the Chip Enable (\overline{CE}) and Write Enable (\overline{WE}) inputs are both LOW. Data on the input pin (D_{IN}) is written into the memory location specified on the address pins (A_0 through A_{17}).

Reading the device is accomplished by taking chip enable (\overline{CE}) LOW while Write Enable (\overline{WE}) remains HIGH. Under these conditions the contents of the memory location specified on the address pins will appear on the data output (D_{OUT}) pin.

The output pin stays in a high-impedance state when Chip Enable (\overline{CE}) is HIGH or Write Enable (\overline{WE}) is LOW.

The CY7C197 utilizes a die coat to insure alpha immunity.

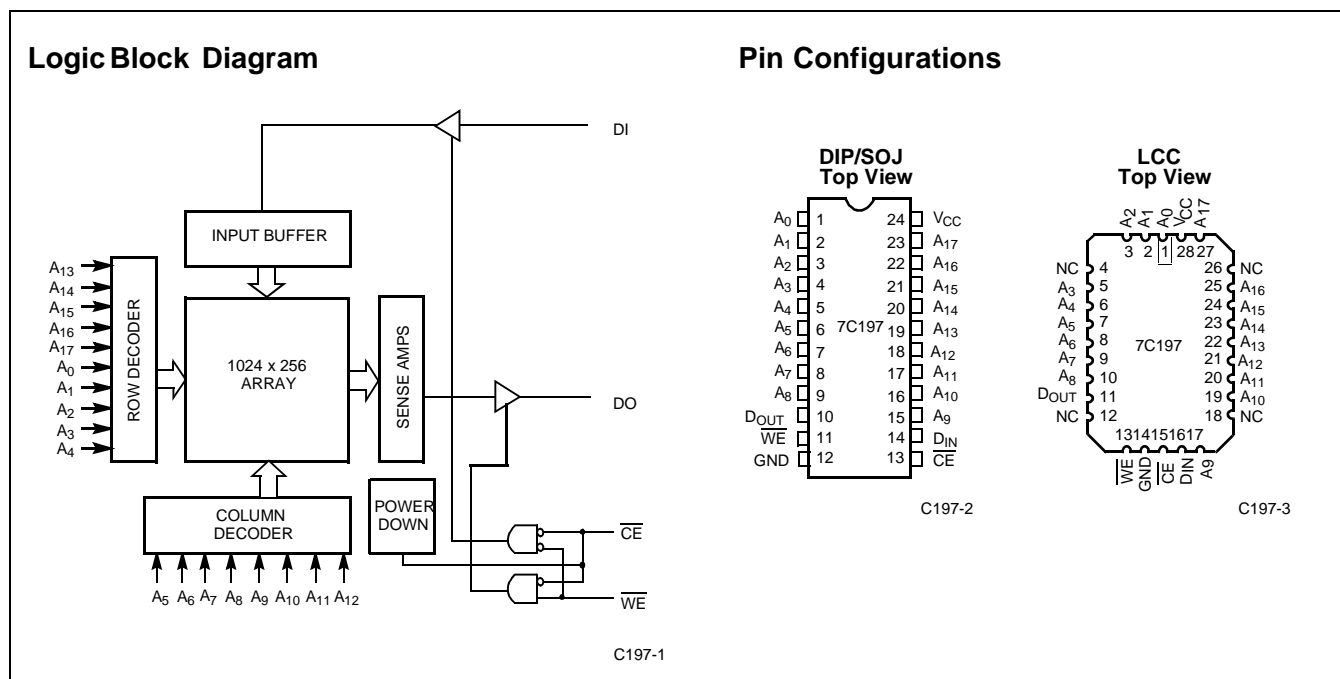

Maximum Ratings

(Above which the useful life may be impaired. For user guidelines, not tested.)

Storage Temperature -65°C to +150°C
 Ambient Temperature with Power Applied..... -55°C to +125°C
 Supply Voltage to Ground Potential (Pin 24 to Pin 12)..... -0.5V to +7.0V
 DC Voltage Applied to Outputs in High Z State^[1] -0.5V to $V_{CC} + 0.5V$

DC Input Voltage^[1]..... -0.5V to $V_{CC} + 0.5V$
 Output Current into Outputs (LOW)..... 20 mA
 Static Discharge Voltage >2001V (per MIL-STD-883, Method 3015)
 Latch-Up Current..... >200 mA

Operating Range

Range	Ambient Temperature	V_{CC}
Commercial	0°C to +70°C	5V ± 10%

Electrical Characteristics Over the Operating Range

Parameter	Description	Test Conditions	7C197-12		7C197-15		Unit
			Min.	Max.	Min.	Max.	
V_{OH}	Output HIGH Voltage	$V_{CC} = \text{Min.}, I_{OH} = -4.0 \text{ mA}$	2.4		2.4		V
V_{OL}	Output LOW Voltage	$V_{CC} = \text{Min.}, I_{OL} = 12.0 \text{ mA}$		0.4		0.4	V
V_{IH}	Input HIGH Voltage		2.2	$V_{CC} + 0.3V$	2.2	$V_{CC} + 0.3V$	V
V_{IL}	Input LOW Voltage ^[1]		-0.5	0.8	-0.5	0.8	V
I_{IX}	Input Load Current	$GND \leq V_I \leq V_{CC}$	-5	+5	-5	+5	µA
I_{OZ}	Output Leakage Current	$GND \leq V_O \leq V_{CC}$, Output Disabled	-5	+5	-5	+5	µA
I_{OS}	Output Short Circuit Current ^[2]	$V_{CC} = \text{Max.}, V_{OUT} = GND$		-300		-300	mA
I_{CC}	V_{CC} Operating Supply Current	$V_{CC} = \text{Max.}, I_{OUT} = 0 \text{ mA}, f = f_{MAX} = 1/t_{RC}$		150		140	mA
I_{SB1}	Automatic \overline{CE} Power-Down Current—TTL Inputs ^[3]	Max. $V_{CC}, \overline{CE} \geq V_{IH}, V_{IN} \geq V_{IH}$ or $V_{IN} \leq V_{IL}, f = f_{MAX}$		30		30	mA
I_{SB2}	Automatic \overline{CE} Power-Down Current—CMOS Inputs ^[3]	Max. $V_{CC}, \overline{CE} \geq V_{CC} - 0.3V, V_{IN} \geq V_{CC} - 0.3V$ or $V_{IN} < 0.3V$		10		10	mA

Notes:

- $V_{(min.)} = -2.0V$ for pulse durations of less than 20 ns.
- Not more than one output should be shorted at one time. Duration of the short circuit should not exceed 30 seconds.
- A pull-up resistor to V_{CC} on the \overline{CE} input is required to keep the device deselected during V_{CC} power-up, otherwise I_{SB} will exceed values given.

Electrical Characteristics Over the Operating Range (continued)

Parameter	Description	Test Conditions	7C197-20		7C197-25, 35, 45		Unit
			Min.	Max.	Min.	Max.	
V _{OH}	Output HIGH Voltage	V _{CC} = Min., I _{OH} = -4.0 mA	2.4		2.4		V
V _{OL}	Output LOW Voltage	V _{CC} = Min., I _{OL} = 12.0 mA		0.4		0.4	V
V _{IH}	Input HIGH Voltage		2.2	V _{CC} + 0.3V	2.2	V _{CC} + 0.3V	V
V _{IL}	Input LOW Voltage ^[1]		-0.5	0.8	-0.5	0.8	V
I _{IX}	Input Load Current	GND ≤ V _I ≤ V _{CC}	-5	+5	-5	+5	μA
I _{OZ}	Output Leakage Current	GND ≤ V _O ≤ V _{CC} , Output Disabled	-5	+5	-5	+5	μA
I _{OS}	Output Short Circuit Current ^[2]	V _{CC} = Max., V _{OUT} = GND		-300		-300	mA
I _{CC}	V _{CC} Operating Supply Current	V _{CC} = Max., I _{OUT} = 0 mA, f = f _{MAX} = 1/t _{RC}		135		95	mA
I _{SB1}	Automatic \overline{CE} Power Down Current—TTL Inputs ^[3]	Max. V _{CC} , $\overline{CE} \geq V_{IH}$, V _{IN} ≥ V _{IH} or V _{IN} ≤ V _{IL} , f = f _{MAX}		30		30	mA
I _{SB2}	Automatic \overline{CE} Power-Down Current—CMOS Inputs ^[3]	Max. V _{CC} , $\overline{CE} \geq V_{CC} - 0.3V$, V _{IN} ≥ V _{CC} - 0.3V or V _{IN} < 0.3V		15		15	mA

Capacitance^[4]

Parameter	Description	Test Conditions	Max.	Unit
C _{IN}	Input Capacitance	T _A = 25°C, f = 1 MHz, V _{CC} = 5.0V	8	pF
C _{OUT}	Output Capacitance		10	pF

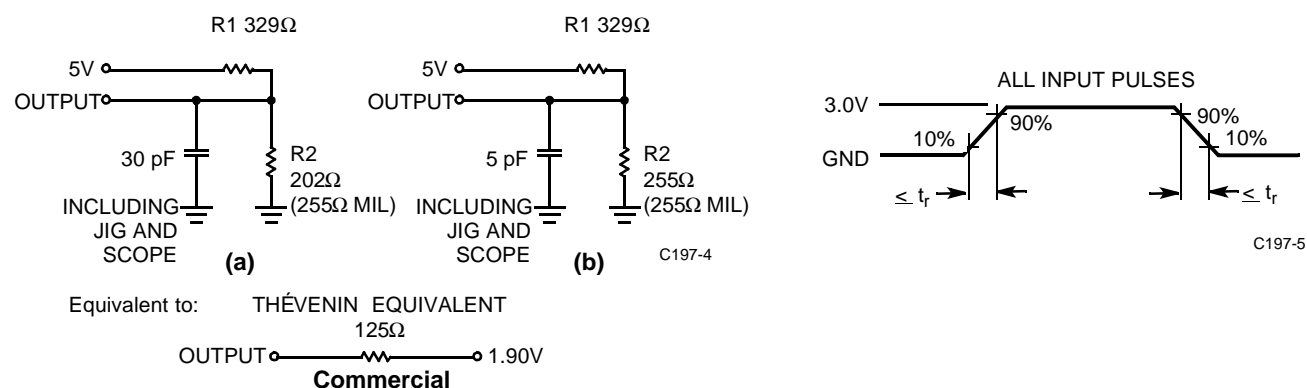
AC Test Loads and Waveforms^[5]

Notes:

4. Tested initially and after any design or process changes that may affect these parameters.
5. t_r = ≤ 3 ns for the -12 and -15 speeds. t_r = ≤ 5 ns for the -20 and slower speeds.

Switching Characteristics Over the Operating Range^[6]

Parameter	Description	7C197-12		7C197-15		7C197-20		7C197-25		7C197-35		7C197-45		Unit
		Min.	Max.	Min.	Max.	Min.	Max.	Min.	Max.	Min.	Max.	Min.	Max.	
READ CYCLE														
t _{RC}	Read Cycle Time	12		15		20		25		35		45		ns
t _{AA}	Address to Data Valid		12		15		20		25		35		45	ns
t _{OHA}	Output Hold from Address Change	3		3		3		3		3		3		ns
t _{ACE}	\overline{CE} LOW to Data Valid		12		15		20		25		35		45	ns
t _{LZCE}	\overline{CE} LOW to Low Z ^[7]	3		3		3		3		3		3		ns
t _{HZCE}	\overline{CE} HIGH to High Z ^[7, 8]		5		7	0	9	0	11	0	15	0	15	ns
t _{PU}	\overline{CE} LOW to Power-Up	0		0		0		0		0		0		ns
t _{PD}	\overline{CE} HIGH to Power-Down		12		15		20		20		25		30	ns
WRITE CYCLE^[9]														
t _{WC}	Write Cycle Time	12		15		20		25		35		45		ns
t _{SCE}	\overline{CE} LOW to Write End	9		10		15		20		30		40		ns
t _{AW}	Address Set-Up to Write End	9		10		15		20		30		40		ns
t _{HA}	Address Hold from Write End	0		0		0		0		0		0		ns
t _{SA}	Address Set-Up to Write Start	0		0		0		0		0		0		ns
t _{PWE}	\overline{WE} Pulse Width	8		9		15		20		25		30		ns
t _{SD}	Data Set-Up to Write End	8		9		10		15		17		20		ns
t _{HD}	Data Hold from Write End	0		0		0		0		0		0		ns
t _{LZWE}	\overline{WE} HIGH to Low Z ^[7]	2		2		3		3		3		3		ns
t _{HZWE}	\overline{WE} LOW to High Z ^[7, 8]		7		7	0	10	0	11	0	15	0	15	ns

Notes:

- Test conditions assume signal transition time of 3 ns or less for -12 and -15 speeds and 5 ns or less for -20 and slower speeds, timing reference levels of 1.5V, input pulse levels of 0 to 3.0V, and output loading of the specified I_{OL}/I_{OH} and 30-pF load capacitance.
- At any given temperature and voltage condition, t_{HZCE} is less than t_{LZCE} and t_{HZWE} is less than t_{LZWE} for any given device.
- t_{HZCE} and t_{HZWE} are specified with C_L = 5 pF as in part (b) in AC Test Loads and Waveforms. Transition is measured ±500 mV from steady-state voltage.
- The internal write time of the memory is defined by the overlap of \overline{CE} LOW and \overline{WE} LOW. Both signals must be LOW to initiate a write and either signal can terminate a write by going HIGH. The data input set-up and hold timing should be referenced to the rising edge of the signal that terminates the write.

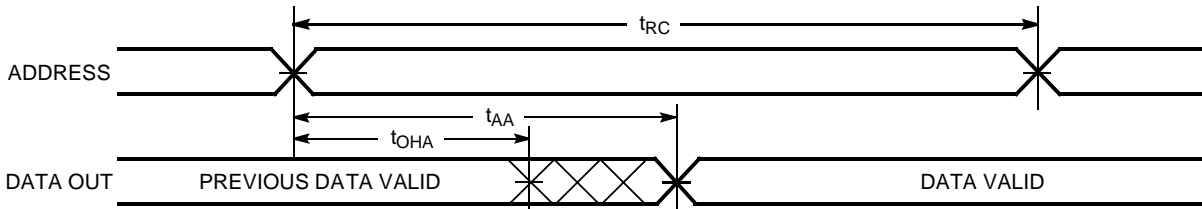
Switching Waveforms
Read Cycle No. 1 ^[10, 11]

C197-6

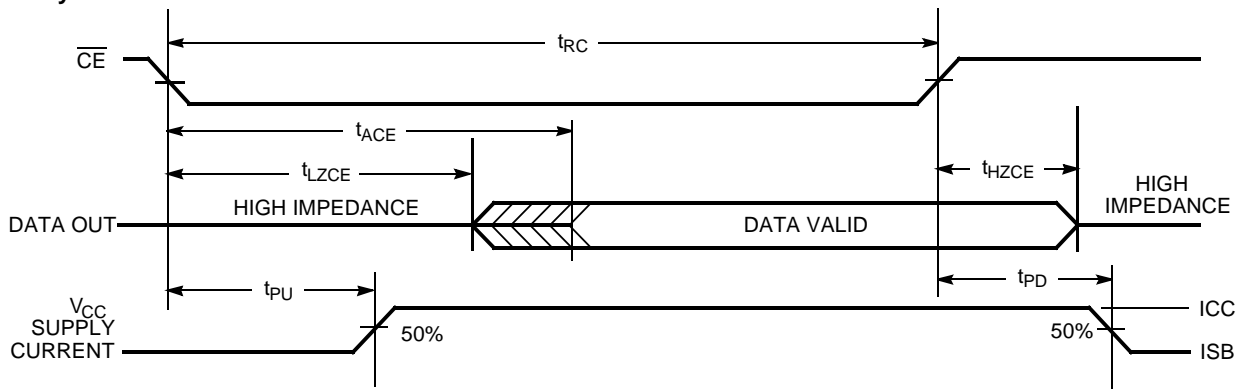
Read Cycle No. 2 ^[10]

C197-7

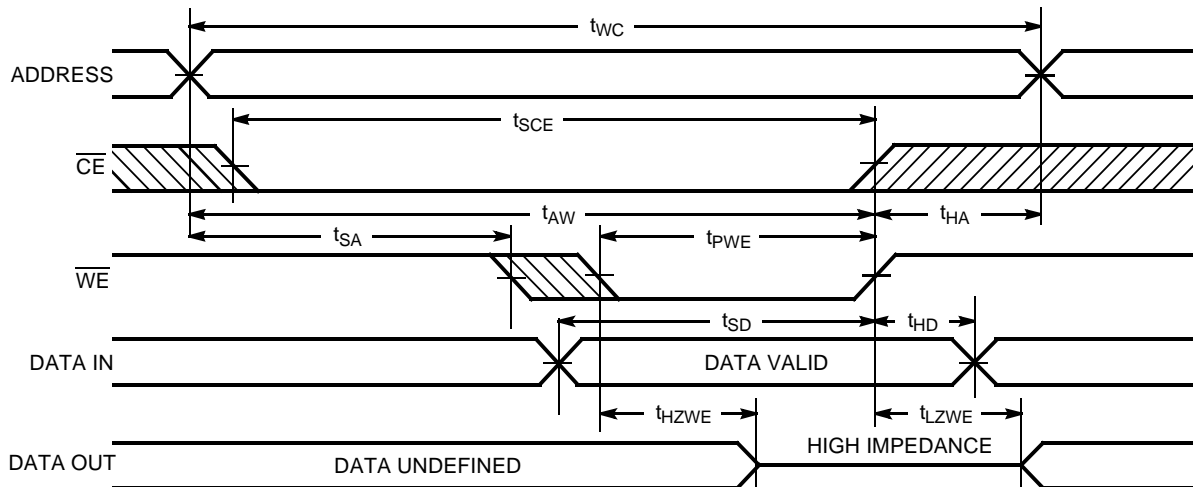
Write Cycle No. 1 (\overline{WE} Controlled) ^[9]

C197-8

Notes:

10. \overline{WE} is HIGH for read cycle.
11. Device is continuously selected, $\overline{CE} = V_{IL}$.

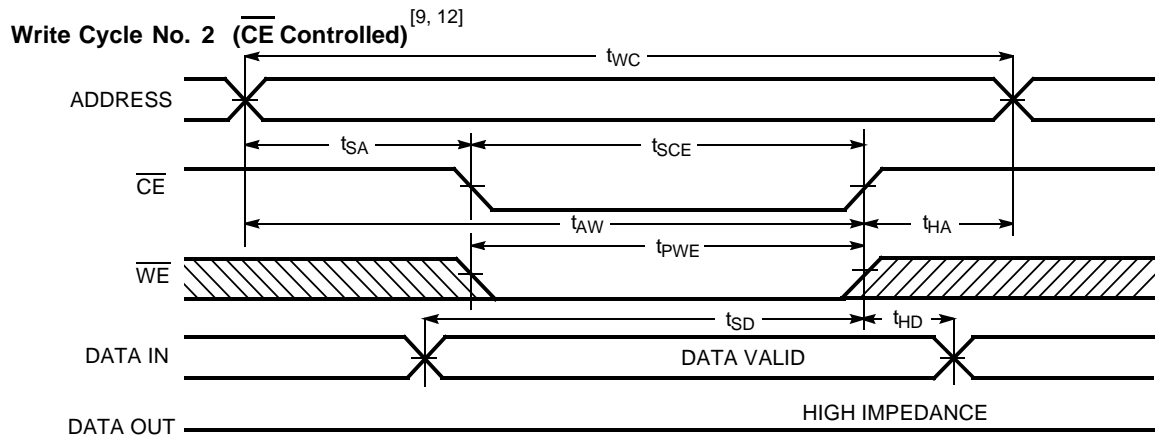
Switching Waveforms (continued)

C197-9

Note:

12. If \overline{CE} goes HIGH simultaneously with \overline{WE} HIGH, the output remains in a high-impedance state.

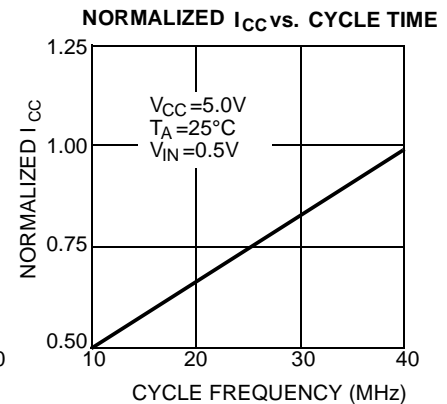
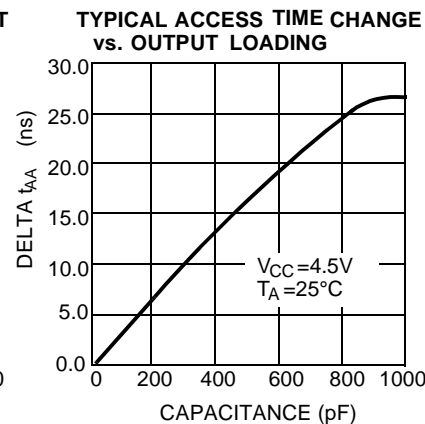
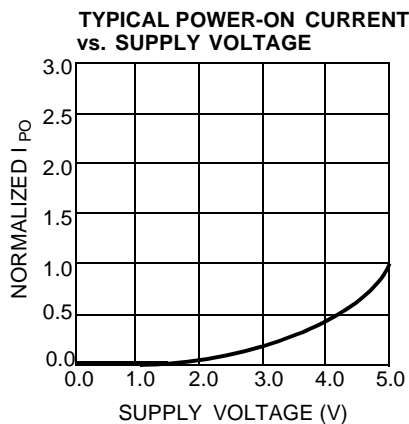
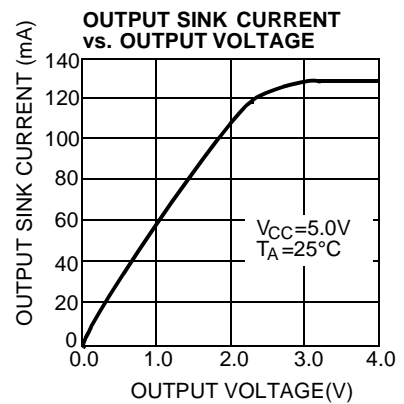
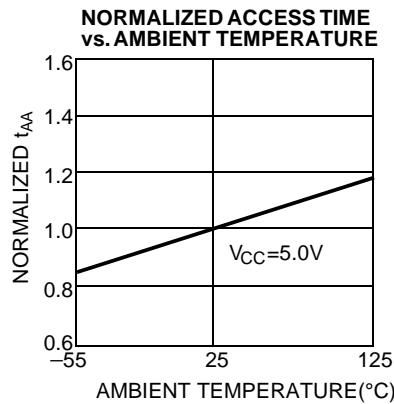
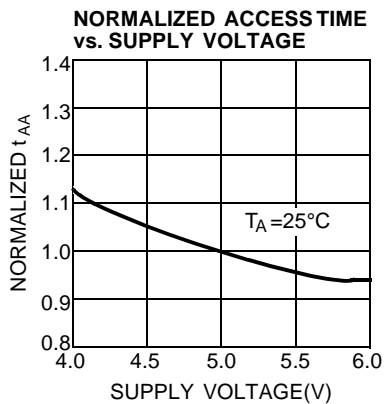
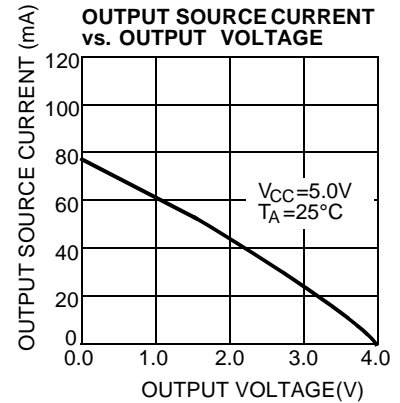
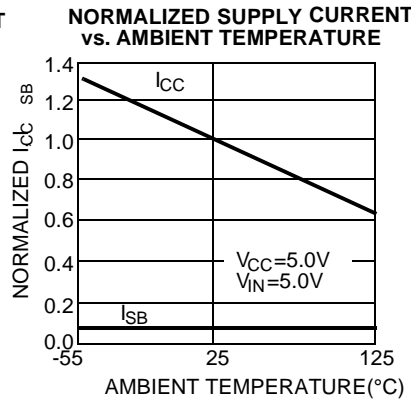
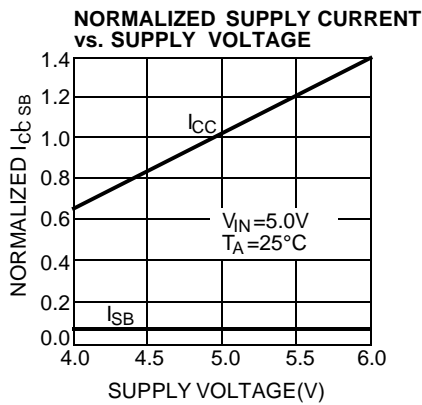
Typical DC and AC Characteristics

CY7C197 Truth Table

CE	WE	Input/Output	Mode
H	X	High Z	Deselect/Power-Down
L	H	Data Out	Read
L	L	Data In	Write

Ordering Information

Speed (ns)	Ordering Code	Package Name	Package Type	Operating Range
12	CY7C197-12PC	P13	24-Lead (300-Mil) Molded DIP	Commercial
	CY7C197-12VC	V13	24-Lead Molded SOJ	
15	CY7C197-15PC	P13	24-Lead (300-Mil) Molded DIP	Commercial
	CY7C197-15VC	V13	24-Lead Molded SOJ	
20	CY7C197-20PC	P13	24-Lead (300-Mil) Molded DIP	Commercial
	CY7C197-20VC	V13	24-Lead Molded SOJ	
25	CY7C197-25PC	P13	24-Lead (300-Mil) Molded DIP	Commercial
	CY7C197-25VC	V13	24-Lead Molded SOJ	
35	CY7C197-35PC	P13	24-Lead (300-Mil) Molded DIP	Commercial
	CY7C197-35VC	V13	24-Lead Molded SOJ	
45	CY7C197-45PC	P13	24-Lead (300-Mil) Molded DIP	Commercial
	CY7C197-45VC	V13	24-Lead Molded SOJ	

Package Diagrams

24-Lead (300-Mil) Molded DIP P13/P13A

DIMENSIONS IN INCHES MIN.
MAX.

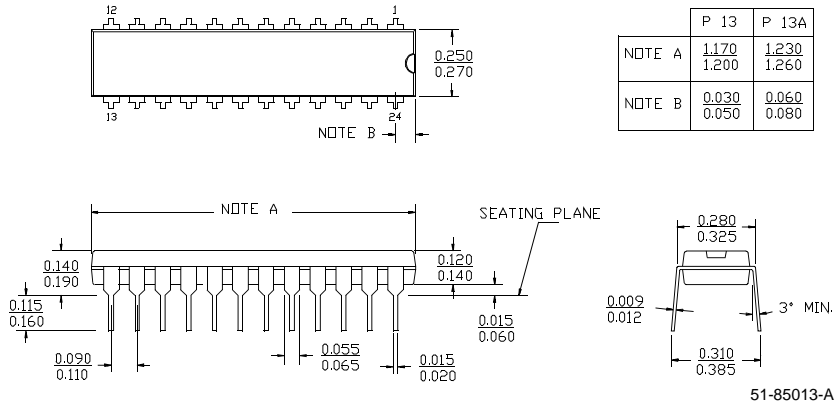

24-Lead (300-Mil) Molded SOJ V13

DIMENSIONS IN INCHES MIN.
MAX.

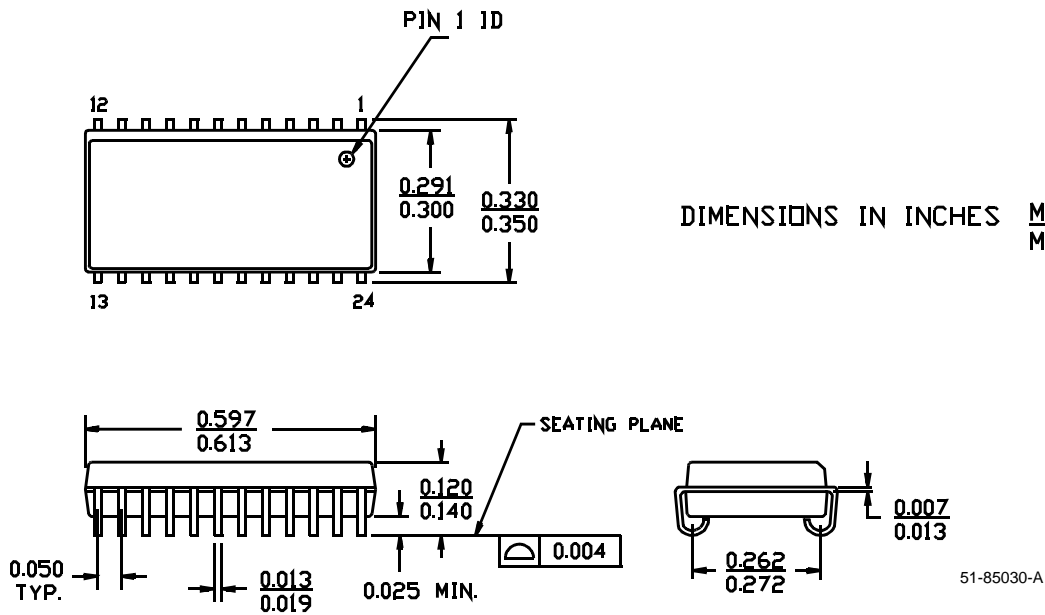

Document Title: CY7C197 256K x 1 Static RAM Document Number: 38-05049				
REV.	ECN NO.	Issue Date	Orig. of Change	Description of Change
**	107151	09/10/01	SZV	Change from Spec number: 38-00078 to 38-05049