

4-Mbit (128K x 36) Pipelined Sync SRAM

Features

- Fully registered inputs and outputs for pipelined operation
- 128K x 36 common IO architecture
- 3.3V core power supply (V_{DD})
- 2.5V/3.3V I/O power supply (V_{DDQ})
- Fast clock-to-output times
— 2.6 ns (for 250-MHz device)
- User-selectable burst counter supporting Intel® Pentium® interleaved or linear burst sequences
- Separate processor and controller address strobes
- Synchronous self-timed writes
- Asynchronous output enable
- Offered in lead-free 100-Pin TQFP, lead-free and non-lead-free 119-Ball BGA package and 165-Ball FBGA package
- “ZZ” sleep mode option and stop clock option
- Available in industrial and commercial temperature ranges

Functional Description^[1]

The CY7C1347G is a 3.3V, 128K x 36 synchronous-pipelined SRAM designed to support zero-wait-state secondary cache with minimal glue logic. CY7C1347G IO pins can operate at either the 2.5V or the 3.3V level; the IO pins are 3.3V tolerant when $V_{DDQ} = 2.5V$. All synchronous inputs pass through input registers controlled by the rising edge of the clock. All data outputs pass through output registers controlled by the rising edge of the clock. Maximum access delay from the clock rise is 2.6 ns (250 MHz device). CY7C1347G supports either the interleaved burst sequence used by the Intel Pentium processor or a linear burst sequence used by processors such as the PowerPC®. The burst sequence is selected through the MODE pin. Accesses can be initiated by asserting either the Address Strobe from Processor (ADSP) or the Address Strobe from Controller (ADSC) at clock rise. Address advancement through the burst sequence is controlled by the ADV input. A 2-bit on-chip wraparound burst counter captures the first address in a burst sequence and automatically increments the address for the rest of the burst access.

Byte write operations are qualified with the four Byte Write Select ($BW_{[A,D]}$) inputs. A Global Write Enable (GW) overrides all byte write inputs and writes data to all four bytes. All writes are conducted with on-chip synchronous self-timed write circuitry.

Three synchronous Chip Selects ($\overline{CE}_1, CE_2, \overline{CE}_3$) and an asynchronous Output Enable (\overline{OE}) provide for easy bank selection and output tri-state control. In order to provide proper data during depth expansion, \overline{OE} is masked during the first clock of a read cycle when emerging from a deselected state.

Selection Guide

	250 MHz	200 MHz	166 MHz	133 MHz	Unit
Maximum Access Time	2.6	2.8	3.5	4.0	ns
Maximum Operating Current	325	265	240	225	mA
Maximum CMOS Standby Current	40	40	40	40	mA

Note

1. For best practice recommendations, refer to the Cypress application note [AN1064, SRAM System Guidelines](#).

Logic Block Diagram

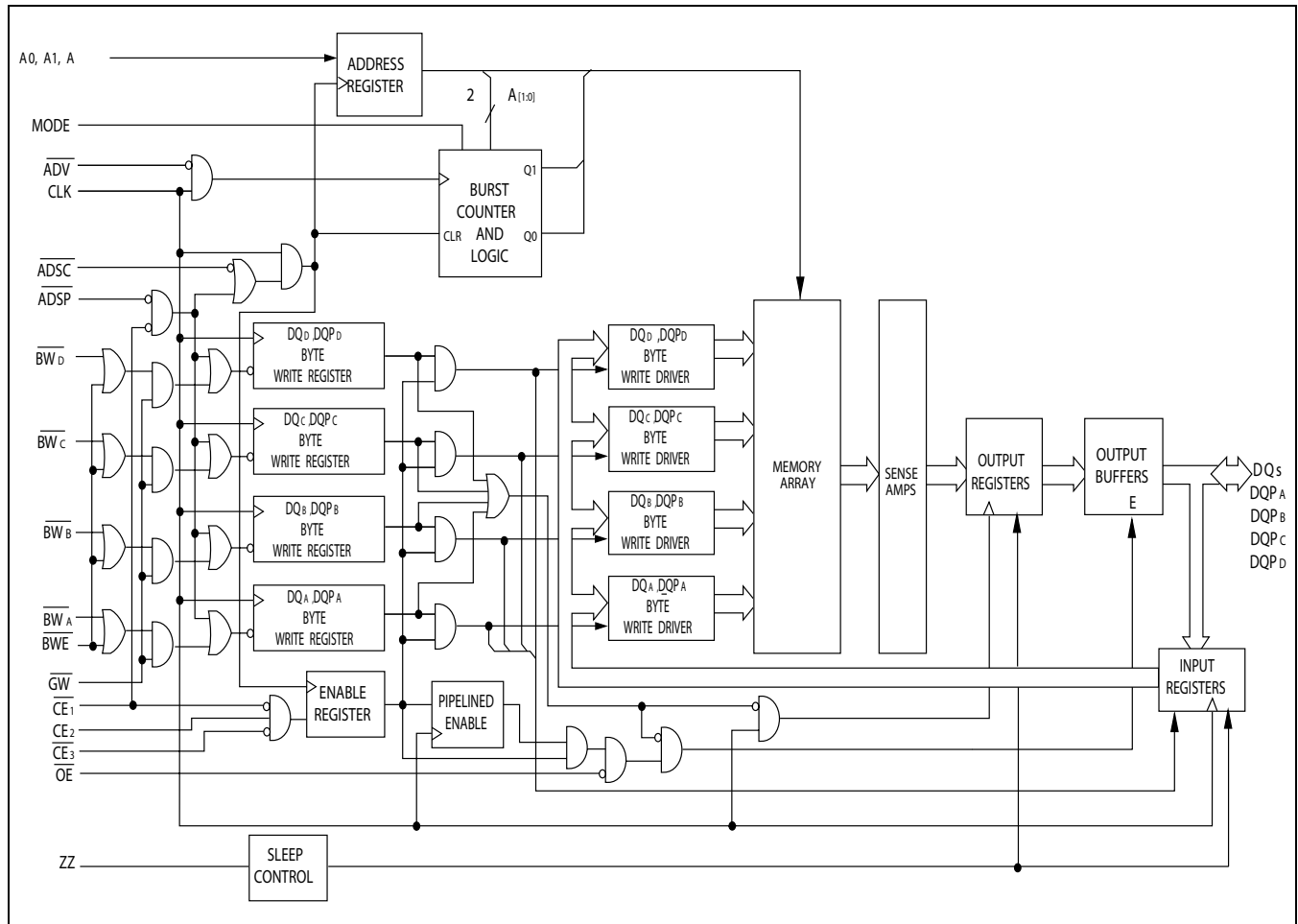

Pin Configurations

100-Pin TQFP Pinout

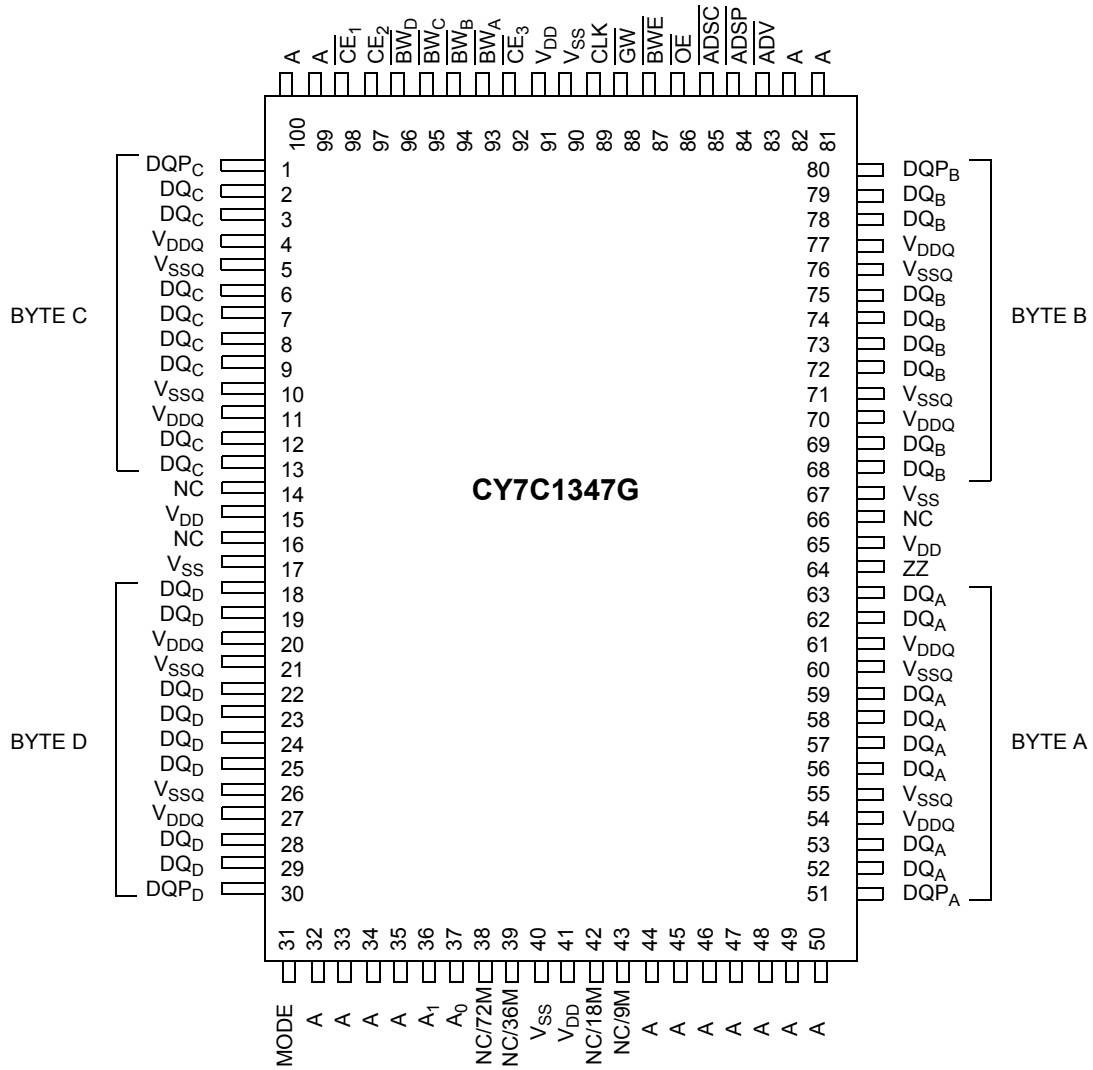

Pin Configurations (continued)

119-Ball BGA Pinout

	1	2	3	4	5	6	7
A	V _{DDQ}	A	A	$\overline{\text{ADSP}}$	A	A	V _{DDQ}
B	NC/288M	CE ₂	A	$\overline{\text{ADSC}}$	A	$\overline{\text{CE}}_3$	NC/576M
C	NC/144M	A	A	V _{DD}	A	A	NC/1G
D	DQ _C	DQP _C	V _{SS}	NC	V _{SS}	DQP _B	DQ _B
E	DQ _C	DQ _C	V _{SS}	$\overline{\text{CE}}_1$	V _{SS}	DQ _B	DQ _B
F	V _{DDQ}	DQ _C	V _{SS}	$\overline{\text{OE}}$	V _{SS}	DQ _B	V _{DDQ}
G	DQ _C	DQ _C	$\overline{\text{BW}}_C$	$\overline{\text{ADV}}$	$\overline{\text{BW}}_B$	DQ _B	DQ _B
H	DQ _C	DQ _C	V _{SS}	$\overline{\text{GW}}$	V _{SS}	DQ _B	DQ _B
J	V _{DDQ}	V _{DD}	NC	V _{DD}	NC	V _{DD}	V _{DDQ}
K	DQ _D	DQ _D	V _{SS}	CLK	V _{SS}	DQ _A	DQ _A
L	DQ _D	DQ _D	$\overline{\text{BW}}_D$	NC	$\overline{\text{BW}}_A$	DQ _A	DQ _A
M	V _{DDQ}	DQ _D	V _{SS}	$\overline{\text{BWE}}$	V _{SS}	DQ _A	V _{DDQ}
N	DQ _D	DQ _D	V _{SS}	A1	V _{SS}	DQ _A	DQ _A
P	DQ _D	DQP _D	V _{SS}	A0	V _{SS}	DQP _A	DQ _A
R	NC	A	MODE	V _{DD}	NC	A	NC
T	NC	NC/72M	A	A	A	NC/36M	ZZ
U	V _{DDQ}	NC	NC	NC	NC	NC	V _{DDQ}

165-Ball FBGA Pinout

	1	2	3	4	5	6	7	8	9	10	11
A	NC/288M	A	$\overline{\text{CE}}_1$	$\overline{\text{BW}}_C$	$\overline{\text{BW}}_B$	$\overline{\text{CE}}_3$	$\overline{\text{BWE}}$	$\overline{\text{ADSC}}$	$\overline{\text{ADV}}$	A	NC
B	NC/144M	A	CE ₂	$\overline{\text{BW}}_D$	$\overline{\text{BW}}_A$	CLK	$\overline{\text{GW}}$	$\overline{\text{OE}}$	$\overline{\text{ADSP}}$	A	NC/576M
C	DQP _C	NC	V _{DDQ}	V _{SS}	V _{SS}	V _{SS}	V _{SS}	V _{SS}	V _{DDQ}	NC/1G	DQP _B
D	DQ _C	DQ _C	V _{DDQ}	V _{DD}	V _{SS}	V _{SS}	V _{SS}	V _{DD}	V _{DDQ}	DQ _B	DQ _B
E	DQ _C	DQ _C	V _{DDQ}	V _{DD}	V _{SS}	V _{SS}	V _{SS}	V _{DD}	V _{DDQ}	DQ _B	DQ _B
F	DQ _C	DQ _C	V _{DDQ}	V _{DD}	V _{SS}	V _{SS}	V _{SS}	V _{DD}	V _{DDQ}	DQ _B	DQ _B
G	DQ _C	DQ _C	V _{DDQ}	V _{DD}	V _{SS}	V _{SS}	V _{SS}	V _{DD}	V _{DDQ}	DQ _B	DQ _B
H	NC	V _{SS}	NC	V _{DD}	V _{SS}	V _{SS}	V _{SS}	V _{DD}	NC	NC	ZZ
J	DQ _D	DQ _D	V _{DDQ}	V _{DD}	V _{SS}	V _{SS}	V _{SS}	V _{DD}	V _{DDQ}	DQ _A	DQ _A
K	DQ _D	DQ _D	V _{DDQ}	V _{DD}	V _{SS}	V _{SS}	V _{SS}	V _{DD}	V _{DDQ}	DQ _A	DQ _A
L	DQ _D	DQ _D	V _{DDQ}	V _{DD}	V _{SS}	V _{SS}	V _{SS}	V _{DD}	V _{DDQ}	DQ _A	DQ _A
M	DQ _D	DQ _D	V _{DDQ}	V _{DD}	V _{SS}	V _{SS}	V _{SS}	V _{DD}	V _{DDQ}	DQ _A	DQ _A
N	DQP _D	NC	V _{DDQ}	V _{SS}	NC	NC/18M	V _{SS}	V _{SS}	V _{DDQ}	NC	DQP _A
P	NC	NC/72M	A	A	NC	A1	NC	A	A	A	NC/9M
R	MODE	NC/36M	A	A	NC	A0	NC	A	A	A	A

Pin Definitions

Name	IO	Description
A ₀ , A ₁ , A	Input-Synchronous	Address Inputs used to select one of the 128K address locations. Sampled at the rising edge of the CLK if ADSP or ADSC is active LOW, and CE ₁ , CE ₂ , and CE ₃ are sampled active. A _[1:0] feeds the 2-bit counter.
\overline{BW}_A , \overline{BW}_B , \overline{BW}_C , \overline{BW}_D	Input-Synchronous	Byte Write Select Inputs, Active LOW. Qualified with \overline{BWE} to conduct byte writes to the SRAM. Sampled on the rising edge of CLK.
\overline{GW}	Input-Synchronous	Global Write Enable Input, Active LOW. When asserted LOW on the rising edge of CLK, a global write is conducted (ALL bytes are written, regardless of the values on $\overline{BW}_{[A:D]}$ and \overline{BWE}).
\overline{BWE}	Input-Synchronous	Byte Write Enable Input, Active LOW. Sampled on the rising edge of CLK. This signal must be asserted LOW to conduct a byte write.
CLK	Input-Clock	Clock Input. Used to capture all synchronous inputs to the device. Also used to increment the burst counter when ADV is asserted LOW, during a burst operation.
\overline{CE}_1	Input-Synchronous	Chip Enable 1 Input, Active LOW. Sampled on the rising edge of CLK. Used in conjunction with CE ₂ and CE ₃ to select or deselect the device. ADSP is ignored if CE ₁ is HIGH. CE ₁ is sampled only when a new external address is loaded.
CE ₂	Input-Synchronous	Chip Enable 2 Input, Active HIGH. Sampled on the rising edge of CLK. Used in conjunction with CE ₁ and CE ₃ to select or deselect the device. CE ₂ is sampled only when a new external address is loaded.
\overline{CE}_3	Input-Synchronous	Chip Enable 3 Input, Active LOW. Sampled on the rising edge of CLK. Used in conjunction with CE ₁ and CE ₂ to select or deselect the device. CE ₃ is sampled only when a new external address is loaded.
\overline{OE}	Input-Asynchronous	Output Enable, Asynchronous Input, Active LOW. Controls the direction of the IO pins. When LOW, the IO pins behave as outputs. When deasserted HIGH, IO pins are tri-stated, and act as input data pins. OE is masked during the first clock of a read cycle when emerging from a deselected state.
\overline{ADV}	Input-Synchronous	Advance Input Signal, sampled on the rising edge of CLK. When asserted, it automatically increments the address in a burst cycle.
\overline{ADSP}	Input-Synchronous	Address Strobe from Processor, sampled on the rising edge of CLK. When asserted LOW, addresses presented to the device are captured in the address registers. A _[1:0] are also loaded into the burst counter. When ADSP and ADSC are both asserted, only ADSP is recognized. ADSP is ignored when \overline{CE}_1 is deasserted HIGH.
\overline{ADSC}	Input-Synchronous	Address Strobe from Controller, sampled on the rising edge of CLK. When asserted LOW, addresses presented to the device are captured in the address registers. A _[1:0] are also loaded into the burst counter. When ADSP and \overline{ADSC} are both asserted, only ADSP is recognized.
ZZ	Input-Asynchronous	ZZ “Sleep” Input. This active HIGH input places the device in a non-time-critical “sleep” condition with data integrity preserved. During normal operation, this pin must be LOW or left floating. ZZ pin has an internal pull down.
DQ _A , DQ _B , DQ _C , DQ _D , DQP _A , DQP _B , DQP _C , DQP _D	IO-Synchronous	Bidirectional Data IO Lines. As inputs, they feed into an on-chip data register that is triggered by the rising edge of CLK. As outputs, they deliver the data contained in the memory location specified by the addresses presented during the previous clock rise of the read cycle. The direction of the pins is controlled by \overline{OE} . When \overline{OE} is asserted LOW, the pins behave as outputs. When HIGH, DQs and DQPs are placed in a tri-state condition.
V _{DD}	Power Supply	Power supply inputs to the core of the device.
V _{SS}	Ground	Ground for the core of the device.
V _{DDQ}	IO Power Supply	Power supply for the IO circuitry.
V _{SSQ}	IO Ground	Ground for the IO circuitry.

Pin Definitions (continued)

Name	IO	Description
MODE	Input-Static	Selects Burst Order. When tied to GND selects linear burst sequence. When tied to V_{DDQ} or left floating selects interleaved burst sequence. This is a strap pin and must remain static during device operation. Mode pin has an internal pull up.
NC, NC/9M, NC/18M, NC/36M, NC/72M, NC/144M, NC/288M, NC/576M, NC/1G	–	No Connects. Not internally connected to the die. NC/9M, NC/18M, NC/36M, NC/72M, NC/144M, NC/288M, NC/576M, and NC/1G are address expansion pins that are not internally connected to the die.

Functional Overview

All synchronous inputs pass through input registers controlled by the rising edge of the clock. All data outputs pass through output registers controlled by the rising edge of the clock. Maximum access delay from the clock rise (t_{CO}) is 2.6 ns (250 MHz device).

The CY7C1347G supports secondary cache in systems using either a linear or interleaved burst sequence. The linear burst sequence is suited for processors that utilize a linear burst sequence. The burst order is user selectable, and is determined by sampling the MODE input. Accesses can be initiated with either the Address Strobe from Processor (\overline{ADSP}) or the Address Strobe from Controller (\overline{ADSC}). Address advancement through the burst sequence is controlled by the \overline{ADV} input. A two-bit on-chip wraparound burst counter captures the first address in a burst sequence and automatically increments the address for the rest of the burst access.

Byte write operations are qualified with the Byte Write Enable (\overline{BWE}) and Byte Write Select ($BW_{[A:D]}$) inputs. A Global Write Enable (\overline{GW}) overrides all byte write inputs and writes data to all four bytes. All writes are simplified with on-chip synchronous self-timed write circuitry.

Three synchronous Chip Selects ($\overline{CE}_1, CE_2, \overline{CE}_3$) and an asynchronous Output Enable (\overline{OE}) provide for easy bank selection and output tri-state control. \overline{ADSP} is ignored if \overline{CE}_1 is HIGH.

Single Read Accesses

This access is initiated when the following conditions are satisfied at clock rise: (1) \overline{ADSP} or \overline{ADSC} is asserted LOW, (2) $\overline{CE}_1, CE_2, CE_3$ are all asserted active, and (3) the write signals ($\overline{GW}, \overline{BWE}$) are all deasserted HIGH. \overline{ADSP} is ignored if \overline{CE}_1 is HIGH. The address presented to the address inputs ($A_{[16:0]}$) is stored into the address advancement logic and the Address Register while being presented to the memory core. The corresponding data is allowed to propagate to the input of the Output Registers. At the rising edge of the next clock the data is allowed to propagate through the Output Register and onto the data bus within 2.6 ns (250 MHz device) if \overline{OE} is active LOW. The only exception occurs when the SRAM is emerging from a deselected state to a selected state, its outputs are always tri-stated during the first cycle of the access. After the first cycle of the access, the outputs are controlled by the \overline{OE} signal. Consecutive single read cycles are supported. After the SRAM is deselected at clock rise by the chip select and either \overline{ADSP} or \overline{ADSC} signals, its output tri-states immediately.

Single Write Accesses Initiated by \overline{ADSP}

This access is initiated when both of the following conditions are satisfied at clock rise: (1) \overline{ADSP} is asserted LOW, and (2) $\overline{CE}_1, CE_2, \overline{CE}_3$ are all asserted active. The address presented to $A_{[16:0]}$ is loaded into the Address Register and the address advancement logic while being delivered to the RAM core. The write signals ($\overline{GW}, \overline{BWE}$, and $BW_{[A:D]}$) and \overline{ADV} inputs are ignored during this first cycle.

\overline{ADSP} -triggered write accesses require two clock cycles to complete. If \overline{GW} is asserted LOW on the second clock rise, the data presented to the DQs and DQPs inputs is written into the corresponding address location in the RAM core. If \overline{GW} is HIGH, then the write operation is controlled by \overline{BWE} and $BW_{[A:D]}$ signals. The CY7C1347G provides byte write capability that is described in “Partial Truth Table for Read/Write” on page 9. Asserting the Byte Write Enable input (\overline{BWE}) with the selected Byte Write ($BW_{[A:D]}$) input selectively writes to only the desired bytes.

Bytes not selected during a byte write operation remain unaltered. A synchronous self-timed write mechanism has been provided to simplify the write operations.

Because the CY7C1347G is a common IO device, the Output Enable (\overline{OE}) must be deasserted HIGH before presenting data to the DQs and DQPs inputs. Doing so tri-states the output drivers. As a safety precaution, DQs and DQPs are automatically tri-stated whenever a write cycle is detected, regardless of the state of \overline{OE} .

Single Write Accesses Initiated by \overline{ADSC}

\overline{ADSC} write accesses are initiated when the following conditions are satisfied: (1) \overline{ADSC} is asserted LOW, (2) \overline{ADSP} is deasserted HIGH, (3) $\overline{CE}_1, CE_2, \overline{CE}_3$ are all asserted active, and (4) the appropriate combination of the write inputs ($\overline{GW}, \overline{BWE}$, and $BW_{[A:D]}$) are asserted active to conduct a write to the desired byte(s). \overline{ADSC} -triggered write accesses require a single clock cycle to complete. The address presented to $A_{[16:0]}$ is loaded into the address register and the address advancement logic while being delivered to the RAM core. The \overline{ADV} input is ignored during this cycle. If a global write is conducted, the data presented to the DQs and DQPs is written into the corresponding address location in the RAM core. If a byte write is conducted, only the selected bytes are written. Bytes not selected during a byte write operation remain unaltered. A synchronous self-timed write mechanism has been provided to simplify the write operations.

Because the CY7C1347G is a common IO device, the Output Enable (\overline{OE}) must be deasserted HIGH before presenting data

to the DQs and DQPs inputs. Doing so tri-states the output drivers. As a safety precaution, DQs and DQPs are automatically tri-stated whenever a write cycle is detected, regardless of the state of \overline{OE} .

Burst Sequences

The CY7C1347G provides a two-bit wraparound counter, fed by $A_{[1:0]}$, that implements either an interleaved or linear burst sequence. The interleaved burst sequence is designed specifically to support Intel Pentium applications. The linear burst sequence is designed to support processors that follow a linear burst sequence. The burst sequence is user-selectable through the MODE input.

Asserting \overline{ADV} LOW at clock rise automatically increments the burst counter to the next address in the burst sequence. Both read and write burst operations are supported.

Sleep Mode

The ZZ input pin is an asynchronous input. Asserting ZZ places the SRAM in a power conservation “sleep” mode. Two clock cycles are required to enter into or exit from this “sleep” mode. While in this mode, data integrity is guaranteed. Accesses pending when entering the “sleep” mode are not considered valid nor is the completion of the operation guaranteed. The device must be deselected before entering the “sleep” mode. \overline{CE}_1 , \overline{CE}_2 , \overline{CE}_3 , \overline{ADSP} , and \overline{ADSC} must remain inactive for the duration of t_{ZZREC} after the ZZ input returns LOW.

Interleaved Burst Sequence

First Address	Second Address	Third Address	Fourth Address
$A_{[1:0]}$	$A_{[1:0]}$	$A_{[1:0]}$	$A_{[1:0]}$
00	01	10	11
01	00	11	10
10	11	00	01
11	10	01	00

Linear Burst Sequence

First Address	Second Address	Third Address	Fourth Address
$A_{[1:0]}$	$A_{[1:0]}$	$A_{[1:0]}$	$A_{[1:0]}$
00	01	10	11
01	10	11	00
10	11	00	01
11	00	01	10

ZZ Mode Electrical Characteristics

Parameter	Description	Test Conditions	Min	Max	Unit
I_{DDZZ}	Snooze mode standby current	$ZZ \geq V_{DD} - 0.2V$		40	mA
t_{ZZS}	Device operation to ZZ	$ZZ \geq V_{DD} - 0.2V$		$2t_{CYC}$	ns
t_{ZZREC}	ZZ recovery time	$ZZ \leq 0.2V$	$2t_{CYC}$		ns
t_{ZZI}	ZZ Active to snooze current	This parameter is sampled		$2t_{CYC}$	ns
t_{RZZI}	ZZ Inactive to exit snooze current	This parameter is sampled	0		ns

Truth Table

The truth table for CY7C1347G follows.^[2, 3, 4, 5, 6]

Next Cycle	Add. Used	\overline{CE}_1	CE_2	\overline{CE}_3	ZZ	\overline{ADSP}	\overline{ADSC}	\overline{ADV}	\overline{WRITE}	\overline{OE}	CLK	DQ
Deselect Cycle, Power Down	None	H	X	X	L	X	L	X	X	X	L-H	Tri-State
Deselect Cycle, Power Down	None	L	L	X	L	L	X	X	X	X	L-H	Tri-State
Deselect Cycle, Power Down	None	L	X	H	L	L	X	X	X	X	L-H	Tri-State
Deselect Cycle, Power Down	None	L	L	X	L	H	L	X	X	X	L-H	Tri-State
Deselect Cycle, Power Down	None	L	X	H	L	H	L	X	X	X	L-H	Tri-State
Snooze Mode, Power Down	None	X	X	X	H	X	X	X	X	X	X	Tri-State
Read Cycle, Begin Burst	External	L	H	L	L	L	X	X	X	L	L-H	Q
Read Cycle, Begin Burst	External	L	H	L	L	L	X	X	X	H	L-H	Tri-State
Write Cycle, Begin Burst	External	L	H	L	L	H	L	X	L	X	L-H	D
Read Cycle, Begin Burst	External	L	H	L	L	H	L	X	H	L	L-H	Q
Read Cycle, Begin Burst	External	L	H	L	L	H	L	X	H	H	L-H	Tri-State
Read Cycle, Continue Burst	Next	X	X	X	L	H	H	L	H	H	L-H	Tri-State
Read Cycle, Continue Burst	Next	X	X	X	L	H	H	L	H	L	L-H	Q
Read Cycle, Continue Burst	Next	H	X	X	L	X	H	L	H	L	L-H	Q
Read Cycle, Continue Burst	Next	H	X	X	L	X	H	L	H	H	L-H	Tri-State
Write Cycle, Continue Burst	Next	X	X	X	L	H	H	L	L	X	L-H	D
Write Cycle, Continue Burst	Next	H	X	X	L	X	H	L	L	X	L-H	D
Read Cycle, Suspend Burst	Current	X	X	X	L	H	H	H	H	L	L-H	Q
Read Cycle, Suspend Burst	Current	X	X	X	L	H	H	H	H	H	L-H	Tri-State
Read Cycle, Suspend Burst	Current	H	X	X	L	X	H	H	H	L	L-H	Q
Read Cycle, Suspend Burst	Current	H	X	X	L	X	H	H	H	H	L-H	Tri-State
Write Cycle, Suspend Burst	Current	X	X	X	L	H	H	H	L	X	L-H	D
Write Cycle, Suspend Burst	Current	H	X	X	L	X	H	H	L	X	L-H	D

Notes:

- X = "Do Not Care." H = Logic HIGH, L = Logic LOW.
- $\overline{WRITE} = L$ when any one or more Byte Write Enable signals ($\overline{BW}_A, \overline{BW}_B, \overline{BW}_C, \overline{BW}_D$) and $\overline{BWE} = L$ or $\overline{GW} = L$. $\overline{WRITE} = H$ when all Byte Write Enable signals ($\overline{BW}_A, \overline{BW}_B, \overline{BW}_C, \overline{BW}_D$), \overline{BWE} , $\overline{GW} = H$.
- The DQ pins are controlled by the current cycle and the \overline{OE} signal. \overline{OE} is asynchronous and is not sampled with the clock.
- The SRAM always initiates a read cycle when \overline{ADSP} is asserted, regardless of the state of \overline{GW} , \overline{BWE} , or $\overline{BW}_{[A,D]}$. Writes may occur only on subsequent clocks after the \overline{ADSP} or with the assertion of \overline{ADSC} . As a result, \overline{OE} must be driven HIGH before the start of the write cycle to allow the outputs to tri-state. \overline{OE} is a don't care for the remainder of the write cycle.
- \overline{OE} is asynchronous and is not sampled with the clock rise. It is masked internally during write cycles. During a read cycle all data bits are tri-state when \overline{OE} is inactive or when the device is deselected, and all data bits behave as output when \overline{OE} is active (LOW).

Partial Truth Table for Read/Write

The partial read/write truth table for CY7C1347G follows.^[2, 7]

Function	\overline{GW}	\overline{BWE}	\overline{BW}_D	\overline{BW}_C	\overline{BW}_B	\overline{BW}_A
Read	H	H	X	X	X	X
Read	H	L	H	H	H	H
Write Byte A – DQ _A	H	L	H	H	H	L
Write Byte B – DQ _B	H	L	H	H	L	H
Write Bytes B, A	H	L	H	H	L	L
Write Byte C– DQ _C	H	L	H	L	H	H
Write Bytes C, A	H	L	H	L	H	L
Write Bytes C, B	H	L	H	L	L	H
Write Bytes C, B, A	H	L	H	L	L	L
Write Byte D– DQ _D	H	L	L	H	H	H
Write Bytes D, A	H	L	L	H	H	L
Write Bytes D, B	H	L	L	H	L	H
Write Bytes D, B, A	H	L	L	H	L	L
Write Bytes D, C	H	L	L	L	H	H
Write Bytes D, C, A	H	L	L	L	H	L
Write Bytes D, C, B	H	L	L	L	L	H
Write All Bytes	H	L	L	L	L	L
Write All Bytes	L	X	X	X	X	X

Note

7. Table is only a partial listing of the byte write combinations. Any combination of BW_x is valid. Appropriate write is based on which byte write is active.

Maximum Ratings

Exceeding the maximum ratings may shorten the battery life of the device. User guidelines are not tested.

Storage Temperature -65°C to +150°C
 Ambient Temperature with Power Applied..... -55°C to +125°C
 Supply Voltage on V_{DD} Relative to GND..... -0.5V to +4.6V
 Supply Voltage on V_{DDQ} Relative to GND -0.5V to +V_{DD}
 DC Voltage Applied to Outputs in High-Z State -0.5V to V_{DD} + 0.5V

DC Input Voltage -0.5V to V_{DD} + 0.5V
 Current into Outputs (LOW)..... 20 mA
 Static Discharge Voltage..... > 2001V (MIL-STD-883, Method 3015)
 Latch Up Current > 200 mA

Operating Range

Range	Ambient Temperature	V _{DD}	V _{DDQ}
Commercial	0°C to +70°C	3.3V -5%/+10%	2.5V -5% to V _{DD}
Industrial	-40°C to +85°C		

Electrical Characteristics

Over the Operating Range [8, 9]

Parameter	Description	Test Conditions	Min	Max	Unit
V _{DD}	Power Supply Voltage		3.135	3.6	V
V _{DDQ}	IO Supply Voltage		2.375	V _{DD}	V
V _{OH}	Output HIGH Voltage	For 3.3V IO, I _{OH} = -4.0 mA	2.4		V
		For 2.5V IO, I _{OH} = -1.0 mA	2.0		V
V _{OL}	Output LOW Voltage	For 3.3V IO, I _{OL} = 8.0 mA		0.4	V
		For 2.5V IO, I _{OL} = 1.0 mA		0.4	V
V _{IH}	Input HIGH Voltage ^[8]	For 3.3V IO	2.0	V _{DD} + 0.3V	V
		For 2.5V IO	1.7	V _{DD} + 0.3V	V
V _{IL}	Input LOW Voltage ^[8]	For 3.3V IO	-0.3	0.8	V
		For 2.5V IO	-0.3	0.7	V
I _X	Input Leakage Current Except ZZ and MODE	GND ≤ V _I ≤ V _{DDQ}	-5	5	μA
	Input Current of MODE	Input = V _{SS}	-30		μA
		Input = V _{DD}		5	μA
	Input Current of ZZ	Input = V _{SS}	-5		μA
		Input = V _{DD}		30	μA
I _{OZ}	Output Leakage Current	GND ≤ V _I ≤ V _{DDQ} , Output Disabled	-5	5	μA
I _{DD}	V _{DD} Operating Supply Current	V _{DD} = Max., I _{OUT} = 0 mA, f = f _{MAX} = 1/t _{CYC}			
		4-ns cycle, 250 MHz		325	mA
		5-ns cycle, 200 MHz		265	mA
		6-ns cycle, 166 MHz		240	mA
		7.5-ns cycle, 133 MHz		225	mA
I _{SB1}	Automatic CE Power Down Current—TTL Inputs	Max. V _{DD} , Device Deselected, V _{IN} ≥ V _{IH} or V _{IN} ≤ V _{IL} , f = f _{MAX} = 1/t _{CYC}			
		4-ns cycle, 250 MHz		120	mA
		5-ns cycle, 200 MHz		110	mA
		6-ns cycle, 166 MHz		100	mA
		7.5-ns cycle, 133 MHz		90	mA
I _{SB2}	Automatic CE Power Down Current—CMOS Inputs	Max. V _{DD} , Device Deselected, V _{IN} ≤ 0.3V or V _{IN} ≥ V _{DDQ} - 0.3V, f = 0		40	mA
		All speeds			

Notes

- Overshoot: V_{IH}(AC) < V_{DD} + 1.5V (pulse width less than t_{CYC}/2). Undershoot: V_{IL}(AC) > -2V (pulse width less than t_{CYC}/2).
- T_{Power-up}: assumes a linear ramp from 0V to V_{DD}(min) within 200 ms. During this time V_{IH} < V_{DD} and V_{DDQ} ≤ V_{DD}.

Electrical Characteristics

Over the Operating Range (continued)^[8, 9]

Parameter	Description	Test Conditions	Min	Max	Unit	
I _{SB3}	Automatic CE Power Down Current—CMOS Inputs	Max. V _{DD} , Device Deselected, or V _{IN} ≤ 0.3V or V _{IN} ≥ V _{DDQ} - 0.3V f = f _{MAX} = 1/t _{CYC}	4-ns cycle, 250 MHz		105	mA
			5-ns cycle, 200 MHz		95	mA
			6-ns cycle, 166 MHz		85	mA
			7.5-ns cycle, 133 MHz		75	mA
I _{SB4}	Automatic CE Power Down Current—TTL Inputs	Max. V _{DD} , Device Deselected, V _{IN} ≥ V _{IH} or V _{IN} ≤ V _{IL} , f = 0		45	mA	

Capacitance

Tested initially and after any design or process changes that may affect these parameters.

Parameter	Description	Test Conditions	100 TQFP Max	119 BGA Max	165 FBGA Max	Unit
C _{IN}	Input Capacitance	T _A = 25°C, f = 1 MHz, V _{DD} = 3.3V, V _{DDQ} = 3.3V	5	5	5	pF
C _{CLK}	Clock Input Capacitance		5	5	5	pF
C _{IO}	Input/Output Capacitance		5	7	7	pF

Thermal Resistance

Tested initially and after any design or process changes that may affect these parameters.

Parameter	Description	Test Conditions	100 TQFP Package	119 BGA Package	165 FBGA Package	Unit
Θ _{JA}	Thermal Resistance (Junction to Ambient)	Test conditions follow standard test methods and procedures for measuring thermal impedance, per EIA/JESD51.	30.32	34.1	20.3	°C/W
Θ _{JC}	Thermal Resistance (Junction to Case)		6.85	14.0	4.6	°C/W

AC Test Loads and Waveforms

Figure 1. AC Test Loads and Waveforms

3.3V I/O Test Load

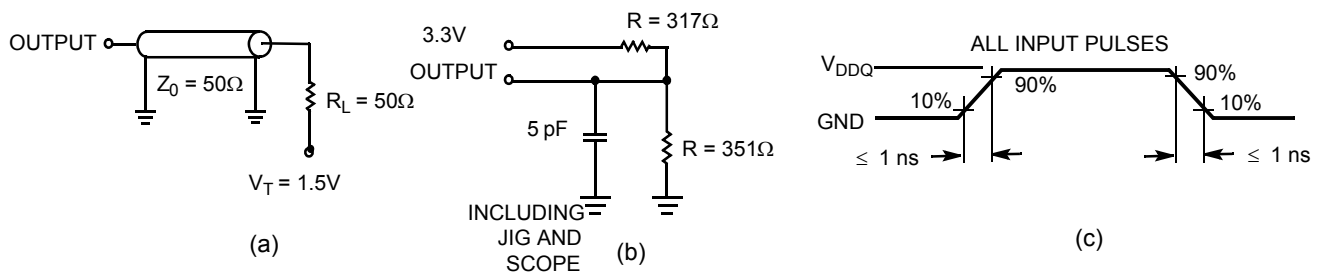

2.5V I/O Test Load

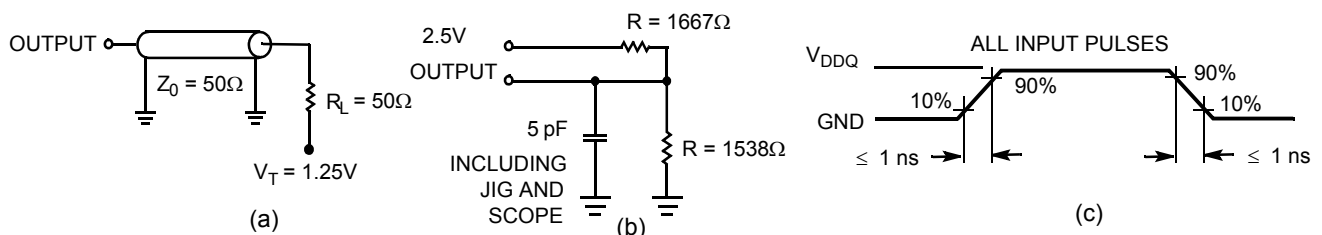

Switching Characteristics

 Over the Operating Range^[14, 15]

Parameter	Description	-250		-200		-166		-133		Unit
		Min	Max	Min	Max	Min	Max	Min	Max	
t _{POWER}	V _{DD} (Typical) to the first Access ^[10]	1		1		1		1		ms
Clock										
t _{CYC}	Clock Cycle Time	4.0		5.0		6.0		7.5		ns
t _{CH}	Clock HIGH	1.7		2.0		2.5		3.0		ns
t _{CL}	Clock LOW	1.7		2.0		2.5		3.0		ns
Output Times										
t _{CO}	Data Output Valid After CLK Rise		2.6		2.8		3.5		4.0	ns
t _{DOH}	Data Output Hold After CLK Rise	1.0		1.0		1.5		1.5		ns
t _{CLZ}	Clock to Low-Z ^[11, 12, 13]	0		0		0		0		ns
t _{CHZ}	Clock to High-Z ^[11, 12, 13]		2.6		2.8		3.5		4.0	ns
t _{OEV}	\overline{OE} LOW to Output Valid		2.6		2.8		3.5		4.5	ns
t _{OELZ}	\overline{OE} LOW to Output Low-Z ^[11, 12, 13]	0		0		0		0		ns
t _{OEHZ}	\overline{OE} HIGH to Output High-Z ^[11, 12, 13]		2.6		2.8		3.5		4.0	ns
Setup Times										
t _{AS}	Address Setup Before CLK Rise	1.2		1.2		1.5		1.5		ns
t _{ADS}	\overline{ADSC} , \overline{ADSP} Setup Before CLK Rise	1.2		1.2		1.5		1.5		ns
t _{ADVS}	\overline{ADV} Setup Before CLK Rise	1.2		1.2		1.5		1.5		ns
t _{WES}	\overline{GW} , \overline{BWE} , \overline{BW}_X Setup Before CLK Rise	1.2		1.2		1.5		1.5		ns
t _{DS}	Data Input Setup Before CLK Rise	1.2		1.2		1.5		1.5		ns
t _{CES}	Chip Enable Setup Before CLK Rise	1.2		1.2		1.5		1.5		ns
Hold Times										
t _{AH}	Address Hold After CLK Rise	0.3		0.5		0.5		0.5		ns
t _{ADH}	\overline{ADSP} , \overline{ADSC} Hold After CLK Rise	0.3		0.5		0.5		0.5		ns
t _{ADVH}	\overline{ADV} Hold After CLK Rise	0.3		0.5		0.5		0.5		ns
t _{WEH}	\overline{GW} , \overline{BWE} , \overline{BW}_X Hold After CLK Rise	0.3		0.5		0.5		0.5		ns
t _{DH}	Data Input Hold After CLK Rise	0.3		0.5		0.5		0.5		ns
t _{CEH}	Chip Enable Hold After CLK Rise	0.3		0.5		0.5		0.5		ns

Notes

- This part has an internal voltage regulator; t_{POWER} is the time that the power must be supplied above V_{DD}(min) initially before a read or write operation can be initiated.
- t_{CHZ}, t_{CLZ}, t_{OELZ}, and t_{OEHZ} are specified with AC test conditions shown in part (b) of "AC Test Loads and Waveforms" on page 11. Transition is measured ±200 mV from steady-state voltage.
- At any voltage and temperature, t_{OEHZ} is less than t_{OELZ} and t_{CHZ} is less than t_{CLZ} to eliminate bus contention between SRAMs when sharing the same data bus. These specifications do not imply a bus contention condition, but reflect parameters guaranteed over worst case user conditions. Device is designed to achieve High-Z prior to Low-Z under the same system conditions.
- This parameter is sampled and not 100% tested.
- Timing references level is 1.5V when V_{DDQ} = 3.3V and is 1.25V when V_{DDQ} = 2.5V on all data sheets.
- Test conditions shown in (a) of "AC Test Loads and Waveforms" on page 11 unless otherwise noted.

Switching Waveforms

Figure 2 shows read cycle timing waveforms.^[16]

Figure 2. Read Cycle Timing

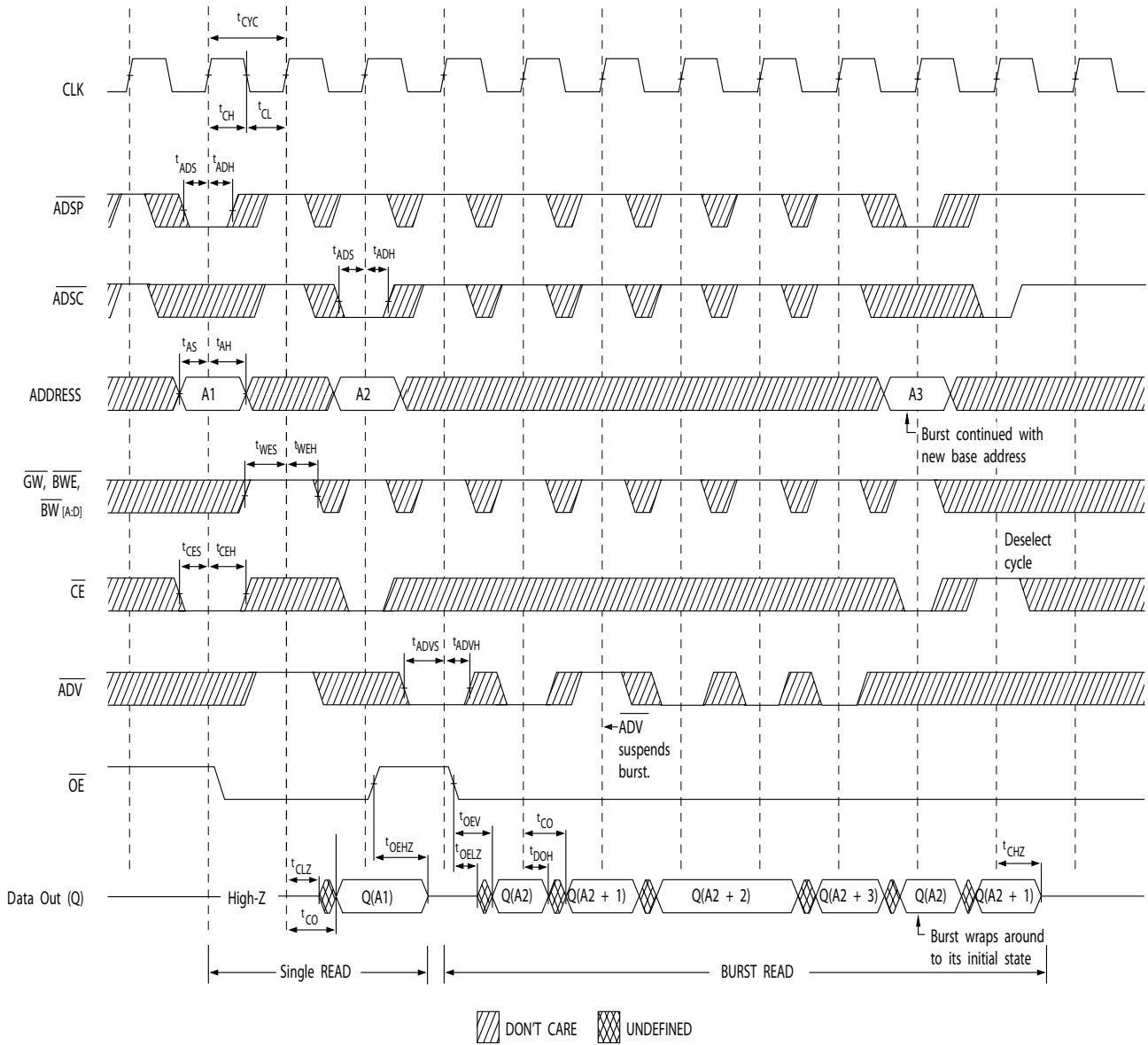

Note

16. On this diagram, when \overline{CE} is LOW, \overline{CE}_1 is LOW, CE_2 is HIGH, and \overline{CE}_3 is LOW. When \overline{CE} is HIGH, \overline{CE}_1 is HIGH, CE_2 is LOW, or \overline{CE}_3 is HIGH.

Switching Waveforms (continued)

Figure 3 shows write cycle timing waveforms.[16, 17]

Figure 3. Write Cycle Timing

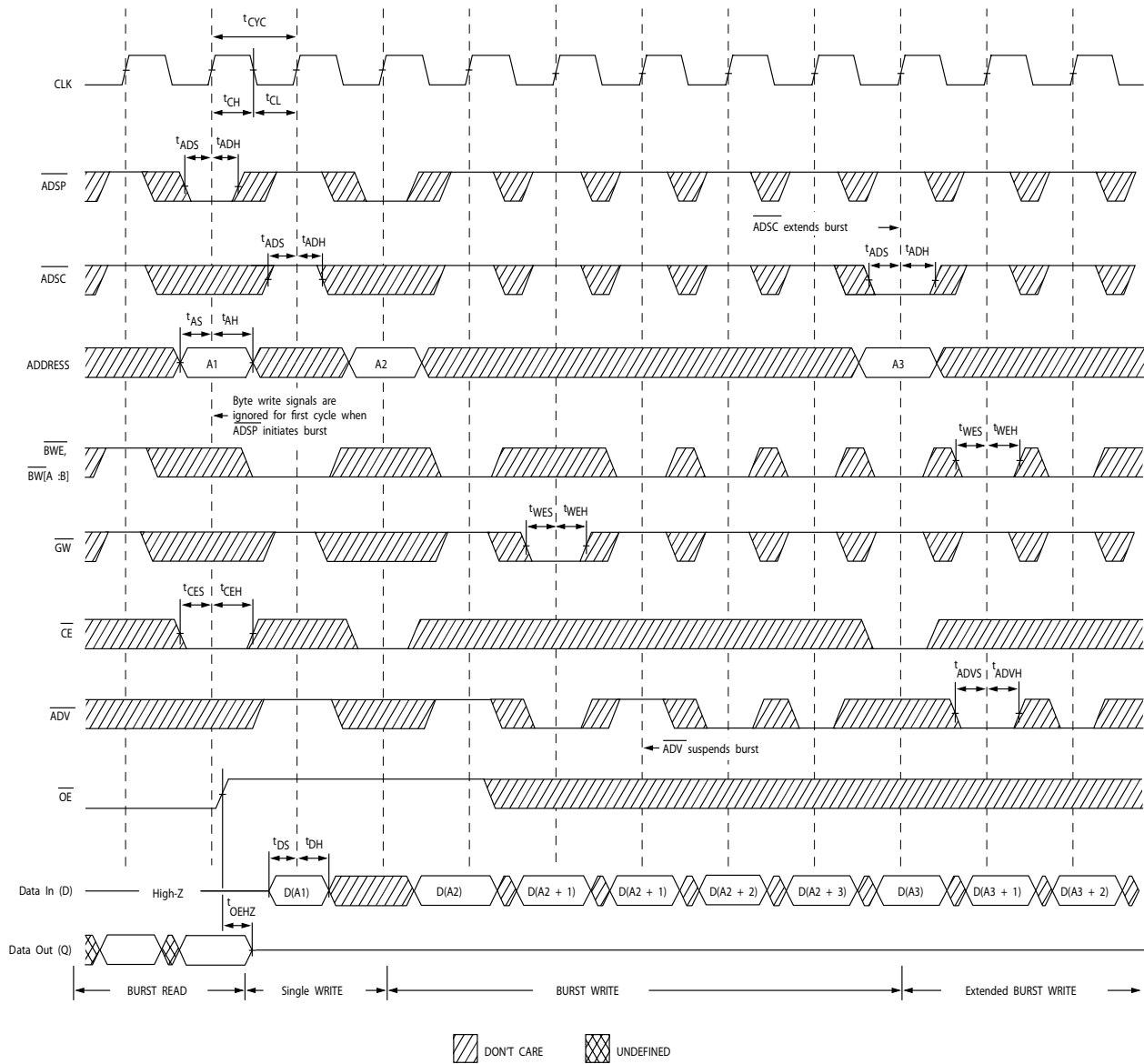

Note

17. Full width write can be initiated by either \overline{GW} LOW, or by \overline{GW} HIGH, \overline{BWE} LOW, and BW_x LOW.

Switching Waveforms (continued)

Figure 4 shows read/write cycle timing waveforms.[16, 18, 19]

Figure 4. Read/Write Cycle Timing

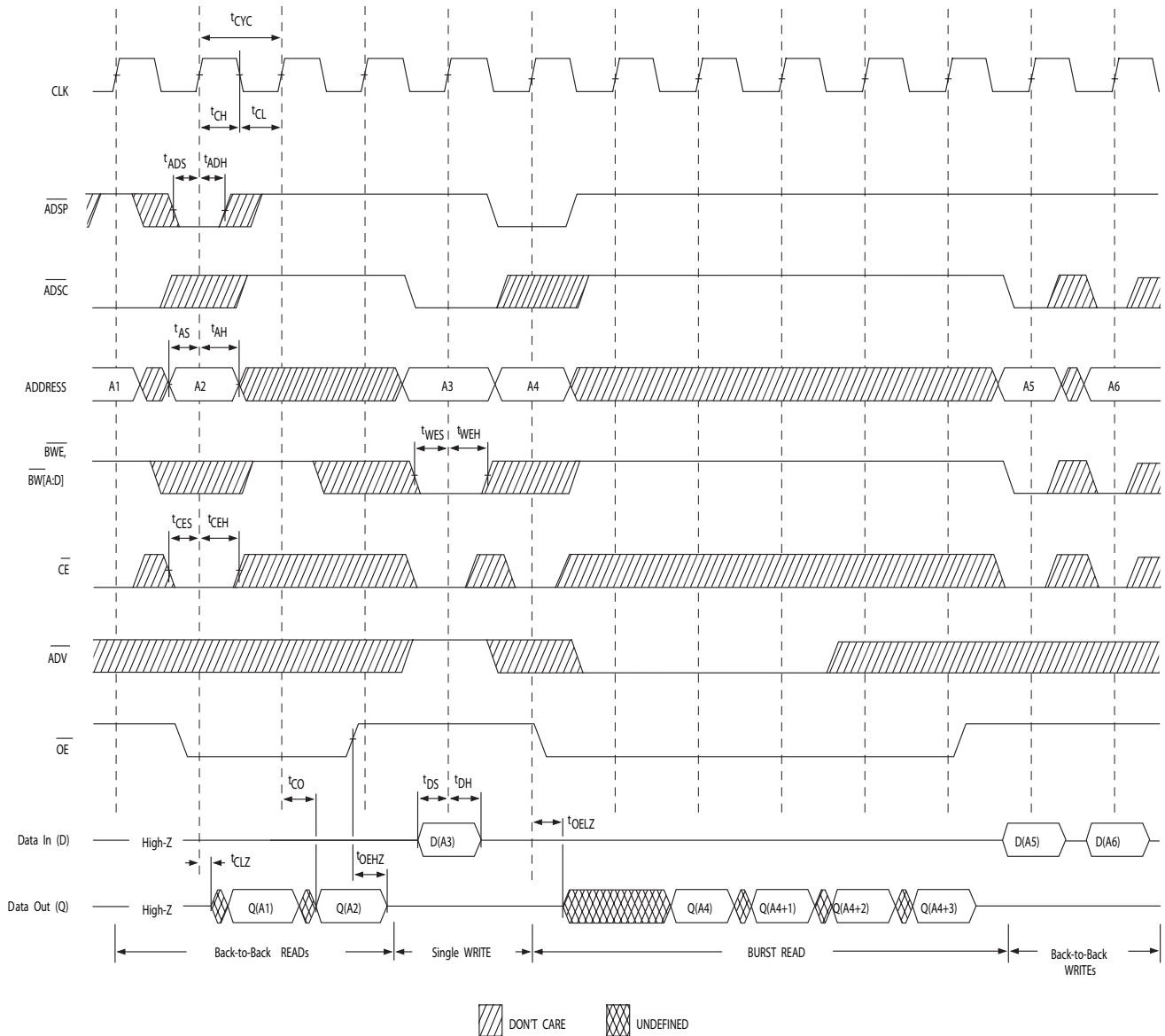

Notes

- 18. The data bus (Q) remains in High-Z following a write cycle, unless a new read access is initiated by \overline{ADSP} or \overline{ADSC} .
- 19. GW is HIGH.

Switching Waveforms (continued)

Figure 5 shows ZZ mode timing waveforms.^[20, 21]

Figure 5. ZZ Mode Timing

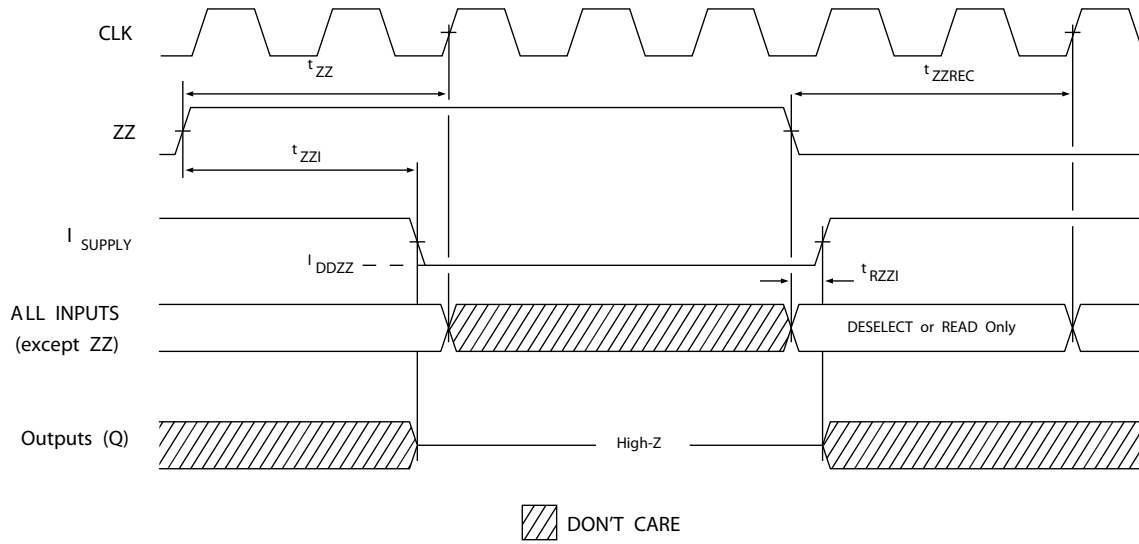

Notes

- 20. Device must be deselected when entering ZZ mode. See "Truth Table" on page 8 for all possible signal conditions to deselect the device.
- 21. DQs are in high-Z when exiting ZZ sleep mode.

Ordering Information

Not all of the speed, package and temperature ranges are available. Please contact your local sales representative or visit www.cypress.com for actual products offered.

Speed (MHz)	Ordering Code	Package Diagram	Package Type	Operating Range
133	CY7C1347G-133AXC	51-85050	100-Pin Thin Quad Flat Pack (14 x 20 x 1.4 mm) Pb-Free	Commercial
	CY7C1347G-133BGC	51-85115	119-Ball Ball Grid Array (14 x 22 x 2.4 mm)	
	CY7C1347G-133BGXC		119-Ball Ball Grid Array (14 x 22 x 2.4 mm) Pb-Free	
	CY7C1347G-133BZC	51-85180	165-Ball Fine-Pitch Ball Grid Array (13 x 15 x 1.4 mm)	
	CY7C1347G-133BZXC		165-Ball Fine-Pitch Ball Grid Array (13 x 15 x 1.4 mm) Pb-Free	
	CY7C1347G-133AXI	51-85050	100-Pin Thin Quad Flat Pack (14 x 20 x 1.4 mm) Pb-Free	
	CY7C1347G-133BGI	51-85115	119-Ball Ball Grid Array (14 x 22 x 2.4 mm)	
	CY7C1347G-133BGXI		119-Ball Ball Grid Array (14 x 22 x 2.4 mm) Pb-Free	
	CY7C1347G-133BZI	51-85180	165-Ball Fine-Pitch Ball Grid Array (13 x 15 x 1.4 mm)	
	CY7C1347G-133BZXI		165-Ball Fine-Pitch Ball Grid Array (13 x 15 x 1.4 mm) Pb-Free	
166	CY7C1347G-166AXC	51-85050	100-Pin Thin Quad Flat Pack (14 x 20 x 1.4 mm) Pb-Free	Commercial
	CY7C1347G-166BGC	51-85115	119-Ball Ball Grid Array (14 x 22 x 2.4 mm)	
	CY7C1347G-166BGXC		119-Ball Ball Grid Array (14 x 22 x 2.4 mm) Pb-Free	
	CY7C1347G-166BZC	51-85180	165-Ball Fine-Pitch Ball Grid Array (13 x 15 x 1.4 mm)	
	CY7C1347G-166BZXC		165-Ball Fine-Pitch Ball Grid Array (13 x 15 x 1.4 mm) Pb-Free	Industrial
	CY7C1347G-166AXI	51-85050	100-Pin Thin Quad Flat Pack (14 x 20 x 1.4 mm) Pb-Free	
	CY7C1347G-166BGI	51-85115	119-Ball Ball Grid Array (14 x 22 x 2.4 mm)	
	CY7C1347G-166BGXI		119-Ball Ball Grid Array (14 x 22 x 2.4 mm) Pb-Free	
	CY7C1347G-166BZI	51-85180	165-Ball Fine-Pitch Ball Grid Array (13 x 15 x 1.4 mm)	
	CY7C1347G-166BZXI		165-Ball Fine-Pitch Ball Grid Array (13 x 15 x 1.4 mm) Pb-Free	
200	CY7C1347G-200AXC	51-85050	100-Pin Thin Quad Flat Pack (14 x 20 x 1.4 mm) Pb-Free	Commercial
	CY7C1347G-200BGC	51-85115	119-Ball Ball Grid Array (14 x 22 x 2.4 mm)	
	CY7C1347G-200BGXC		119-Ball Ball Grid Array (14 x 22 x 2.4 mm) Pb-Free	
	CY7C1347G-200BZC	51-85180	165-Ball Fine-Pitch Ball Grid Array (13 x 15 x 1.4 mm)	
	CY7C1347G-200BZXC		165-Ball Fine-Pitch Ball Grid Array (13 x 15 x 1.4 mm) Pb-Free	Industrial
	CY7C1347G-200AXI	51-85050	100-Pin Thin Quad Flat Pack (14 x 20 x 1.4 mm) Pb-Free	
	CY7C1347G-200BGI	51-85115	119-Ball Ball Grid Array (14 x 22 x 2.4 mm)	
	CY7C1347G-200BGXI		119-Ball Ball Grid Array (14 x 22 x 2.4 mm) Pb-Free	
	CY7C1347G-200BZI	51-85180	165-Ball Fine-Pitch Ball Grid Array (13 x 15 x 1.4 mm)	
	CY7C1347G-200BZXI		165-Ball Fine-Pitch Ball Grid Array (13 x 15 x 1.4 mm) Pb-Free	
250	CY7C1347G-250AXC	51-85050	100-Pin Thin Quad Flat Pack (14 x 20 x 1.4 mm) Pb-Free	Commercial
	CY7C1347G-250BGC	51-85115	119-Ball Ball Grid Array (14 x 22 x 2.4 mm)	
	CY7C1347G-250BGXC		119-Ball Ball Grid Array (14 x 22 x 2.4 mm) Pb-Free	
	CY7C1347G-250BZC	51-85180	165-Ball Fine-Pitch Ball Grid Array (13 x 15 x 1.4 mm)	
	CY7C1347G-250BZXC		165-Ball Fine-Pitch Ball Grid Array (13 x 15 x 1.4 mm) Pb-Free	Industrial
	CY7C1347G-250AXI	51-85050	100-Pin Thin Quad Flat Pack (14 x 20 x 1.4 mm) Pb-Free	
	CY7C1347G-250BGI	51-85115	119-Ball Ball Grid Array (14 x 22 x 2.4 mm)	
	CY7C1347G-250BGXI		119-Ball Ball Grid Array (14 x 22 x 2.4 mm) Pb-Free	
	CY7C1347G-250BZI	51-85180	165-Ball Fine-Pitch Ball Grid Array (13 x 15 x 1.4 mm)	
	CY7C1347G-250BZXI		165-Ball Fine-Pitch Ball Grid Array (13 x 15 x 1.4 mm) Pb-Free	

Package Diagrams

Figure 6. 100-Pin Thin Plastic Quad Flatpack (14 x 20 x 1.4 mm), 51-85050

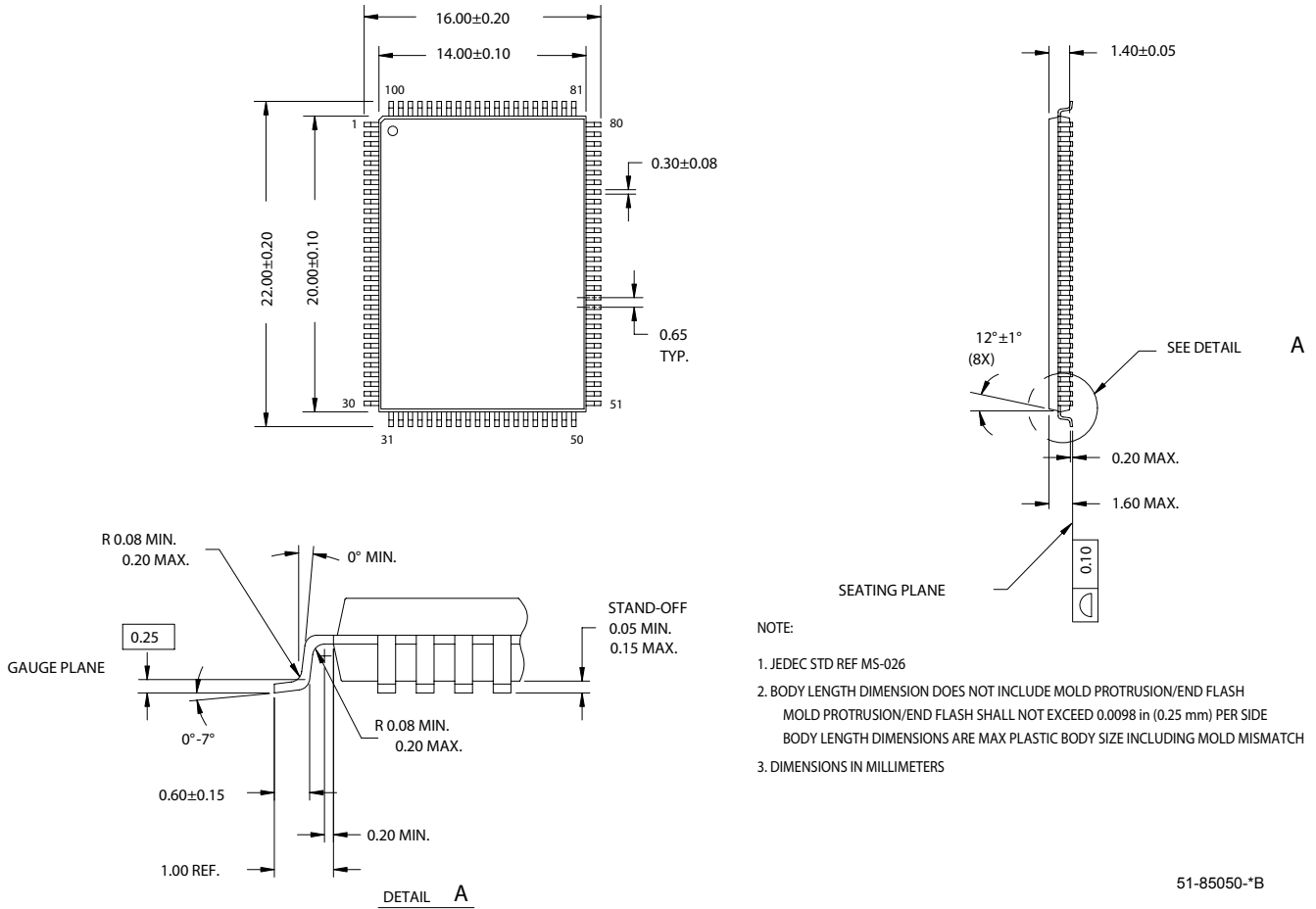

Package Diagrams (continued)

Figure 7.119-Ball BGA (14 x 22 x 2.4 mm), 51-85115

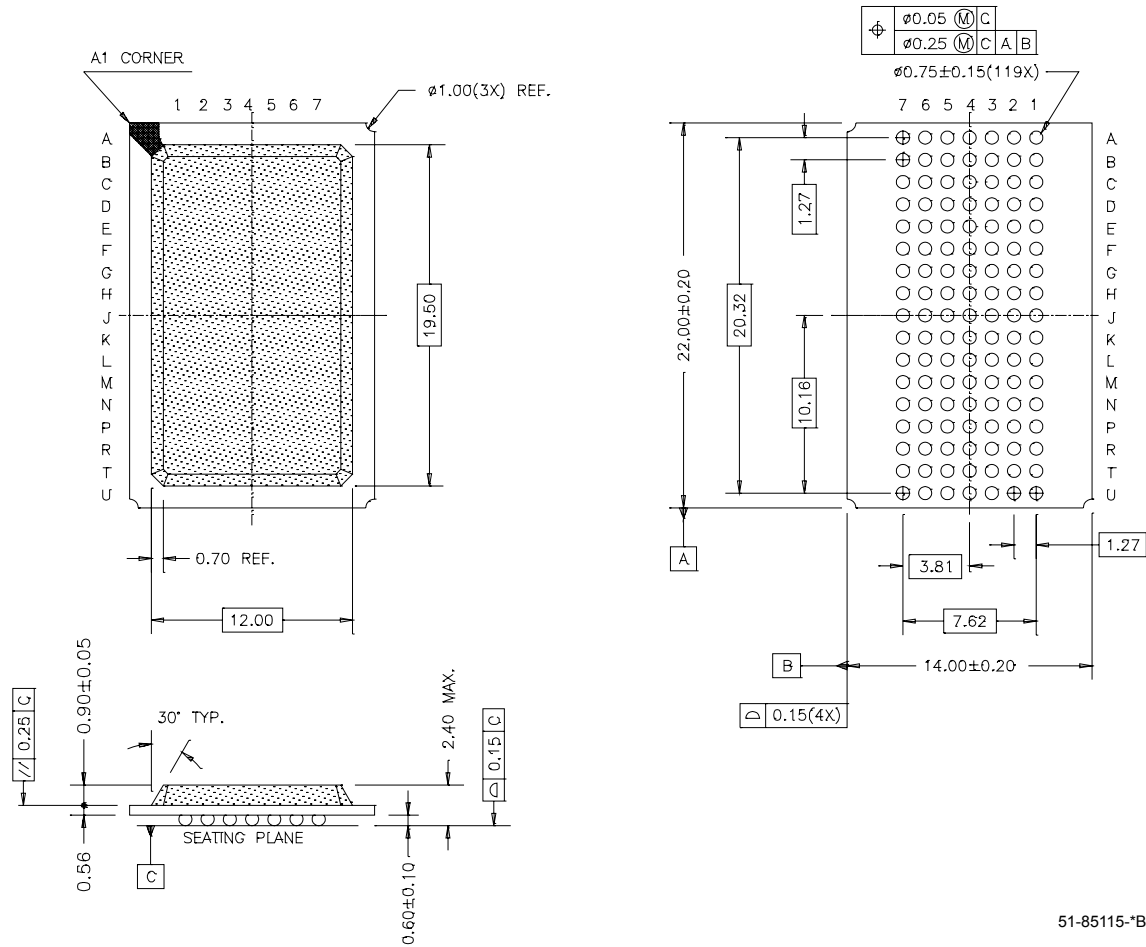

51-85115-B

Package Diagrams (continued)

Figure 8. 165-Ball FBGA (13 x 15 x 1.4 mm), 51-85180

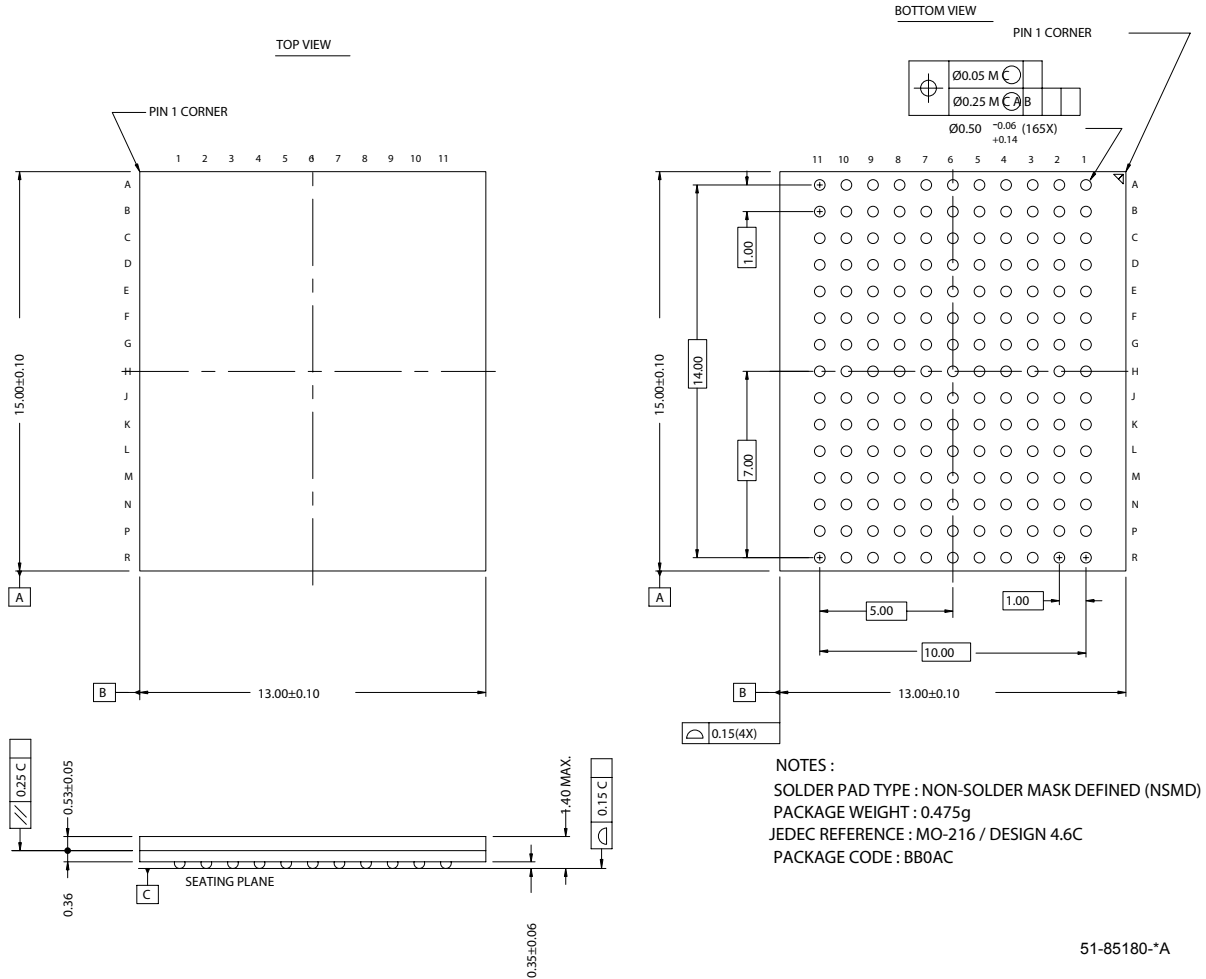

51-85180-*A

© Cypress Semiconductor Corporation, 2004-2007. The information contained herein is subject to change without notice. Cypress Semiconductor Corporation assumes no responsibility for the use of any circuitry other than circuitry embodied in a Cypress product. Nor does it convey or imply any license under patent or other rights. Cypress products are not warranted nor intended to be used for medical, life support, life saving, critical control or safety applications, unless pursuant to an express written agreement with Cypress. Furthermore, Cypress does not authorize its products for use as critical components in life-support systems where a malfunction or failure may reasonably be expected to result in significant injury to the user. The inclusion of Cypress products in life-support systems application implies that the manufacturer assumes all risk of such use and in doing so indemnifies Cypress against all charges.

Intel and Pentium are registered trademarks of Intel Corporation. PowerPC is a registered trademark of International Business Machines, Inc. All product and company names mentioned in this document may be the trademarks of their respective holders.

Any Source Code (software and/or firmware) is owned by Cypress Semiconductor Corporation (Cypress) and is protected by and subject to worldwide patent protection (United States and foreign), United States copyright laws and international treaty provisions. Cypress hereby grants to licensee a personal, non-exclusive, non-transferable license to copy, use, modify, create derivative works of, and compile the Cypress Source Code and derivative works for the sole purpose of creating custom software and or firmware in support of licensee product to be used only in conjunction with a Cypress integrated circuit as specified in the applicable agreement. Any reproduction, modification, translation, compilation, or representation of this Source Code except as specified above is prohibited without the express written permission of Cypress.

Disclaimer: CYPRESS MAKES NO WARRANTY OF ANY KIND, EXPRESS OR IMPLIED, WITH REGARD TO THIS MATERIAL, INCLUDING, BUT NOT LIMITED TO, THE IMPLIED WARRANTIES OF MERCHANTABILITY AND FITNESS FOR A PARTICULAR PURPOSE. Cypress reserves the right to make changes without further notice to the materials described herein. Cypress does not assume any liability arising out of the application or use of any product or circuit described herein. Cypress does not authorize its products for use as critical components in life-support systems where a malfunction or failure may reasonably be expected to result in significant injury to the user. The inclusion of Cypress' product in a life-support systems application implies that the manufacturer assumes all risk of such use and in doing so indemnifies Cypress against all charges.

Use may be limited by and subject to the applicable Cypress software license agreement.

Document History Page

Document Title: CY7C1347G 4-Mbit (128K x 36) Pipelined Sync SRAM				
Document Number: 38-05516				
REV.	ECN NO.	Issue Date	Orig. of Change	Description of Change
**	224364	See ECN	RKF	New data sheet
*A	276690	See ECN	VBL	Changed TQFP package in Ordering Information section to lead-free TQFP Added comment of BG and BZ lead-free package availability
*B	333625	See ECN	SYT	Removed 225-MHz and 100-MHz speed grades Modified Address Expansion balls in the pinouts for 100 TQFP Package as per JEDEC standards and updated the Pin Definitions accordingly Modified V_{OL} , V_{OH} test conditions Replaced TBDs for θ_{JA} and θ_{JC} to their respective values on the Thermal Resistance table Changed the package name for 100 TQFP from A100RA to A101 Removed comment on the availability of BG lead-free package Updated the Ordering Information by shading and unshading MPNs as per availability
*C	419256	See ECN	R XU	Converted from Preliminary to Final. Changed address of Cypress Semiconductor Corporation on Page #1 from "3901 North First Street" to "198 Champion Court" Swapped typo \overline{CE}_2 and \overline{CE}_3 in the Truth Table column heading on Page #6 Modified test condition from $V_{IH} \leq V_{DD}$ to $V_{IH} < V_{DD}$. Modified test condition from $V_{DDQ} < V_{DD}$ to $V_{DDQ} \leq V_{DD}$ Modified "Input Load" to "Input Leakage Current except ZZ and MODE" in the Electrical Characteristics Table. Replaced Package Name column with Package Diagram in the Ordering Information table. Replaced Package Diagram of 51-85050 from *A to *B Replaced Package Diagram of 51-85180 from ** to *A Updated the Ordering Information.
*D	480124	See ECN	VKN	Added the Maximum Rating for Supply Voltage on V_{DDQ} Relative to GND. Updated the Ordering Information table.
*E	1078184	See ECN	VKN	Corrected write timing diagram on page 12