

4-Mbit (256 K × 18) Pipelined Sync SRAM

Features

- Registered inputs and outputs for pipelined operation
- 256 K × 18 common I/O Architecture
- 3.3 V core power supply (V_{DD})
- 2.5 V I/O power supply (V_{DDQ})
- Fast clock-to-output times
 - 3.5 ns (for 166-MHz device)
- Provide high performance 3-1-1-1 access rate
- User-selectable burst counter supporting Intel® Pentium® interleaved or linear burst sequences
- Separate processor and controller address strobes
- Synchronous self-timed writes
- Asynchronous output enable
- Offered in Pb-free 100-pin TQFP package
- “ZZ” sleep mode option

Functional Description

The CY7C1327G SRAM integrates 256 K × 18 SRAM cells with advanced synchronous peripheral circuitry and a two-bit counter for internal burst operation. All synchronous inputs are gated by registers controlled by a positive-edge-triggered clock input (CLK). The synchronous inputs include all addresses, all data inputs, address-pipelining chip enable (\overline{CE}_1), depth-expansion chip enables (\overline{CE}_2 and \overline{CE}_3), burst control inputs (ADSC, ADSP, and ADV), write enables ($BW_{[A:B]}$, and BWE), and global write (\overline{GW}). Asynchronous inputs include the output enable (\overline{OE}) and the ZZ pin.

Addresses and chip enables are registered at rising edge of clock when either address strobe processor (ADSP) or address strobe controller (ADSC) are active. Subsequent burst addresses can be internally generated as controlled by the advance pin (ADV).

Address, data inputs, and write controls are registered on-chip to initiate a self-timed Write cycle. This part supports byte write operations (see Pin Descriptions and Truth Table for further details). Write cycles can be one to two bytes wide as controlled by the byte write control inputs. \overline{GW} when active LOW causes all bytes to be written.

The CY7C1327G operates from a +3.3 V core power supply while all outputs also operate with a +3.3 V or a +2.5 V supply. All inputs and outputs are JEDEC-standard JESD8-5-compatible.

Logic Block Diagram

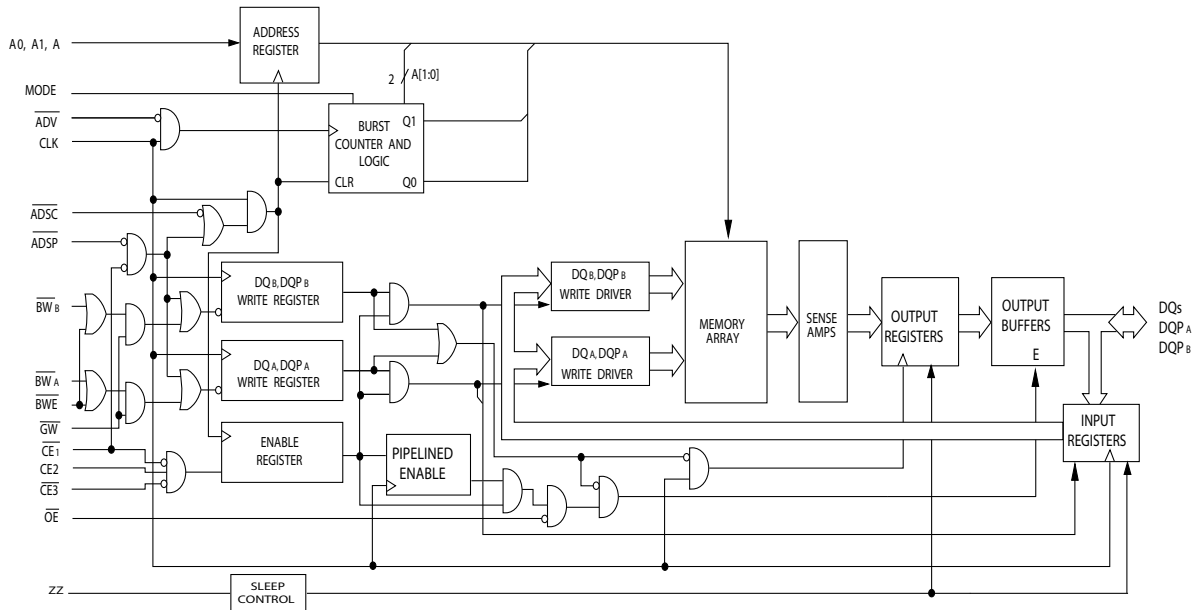

Errata: For information on silicon errata, see "Errata" on page 20. Details include trigger conditions, devices affected, and proposed workaround.

Contents

Selection Guide	3	AC Test Loads and Waveforms	11
Pin Configurations	3	Switching Characteristics	12
Pin Definitions	4	Switching Waveforms	13
Functional Overview	5	Ordering Information	17
Single Read Accesses	5	Ordering Code Definitions	17
Single Write Accesses Initiated by ADSP	5	Package Diagrams	18
Single Write Accesses Initiated by ADSC	5	Acronyms	19
Burst Sequences	5	Document Conventions	19
Sleep Mode	5	Units of Measure	19
Interleaved Burst Address Table	6	Errata	20
Linear Burst Address Table	6	Part Numbers Affected	20
ZZ Mode Electrical Characteristics	6	Product Status	20
Truth Table	7	Ram9 Sync/NoBL ZZ Pin Issues Errata Summary	20
Truth Table for Read/Write	8	Document History Page	21
Maximum Ratings	9	Sales, Solutions, and Legal Information	23
Operating Range	9	Worldwide Sales and Design Support	23
Neutron Soft Error Immunity	9	Products	23
Electrical Characteristics	9	PSoC® Solutions	23
Capacitance	10	Cypress Developer Community	23
Thermal Resistance	10	Technical Support	23

Selection Guide

Description	166 MHz	133 MHz	Unit
Maximum access time	3.5	4.0	ns
Maximum operating current	240	225	mA
Maximum CMOS standby current	40	40	mA

Pin Configurations

Figure 1. 100-pin TQFP Pinout^[1]

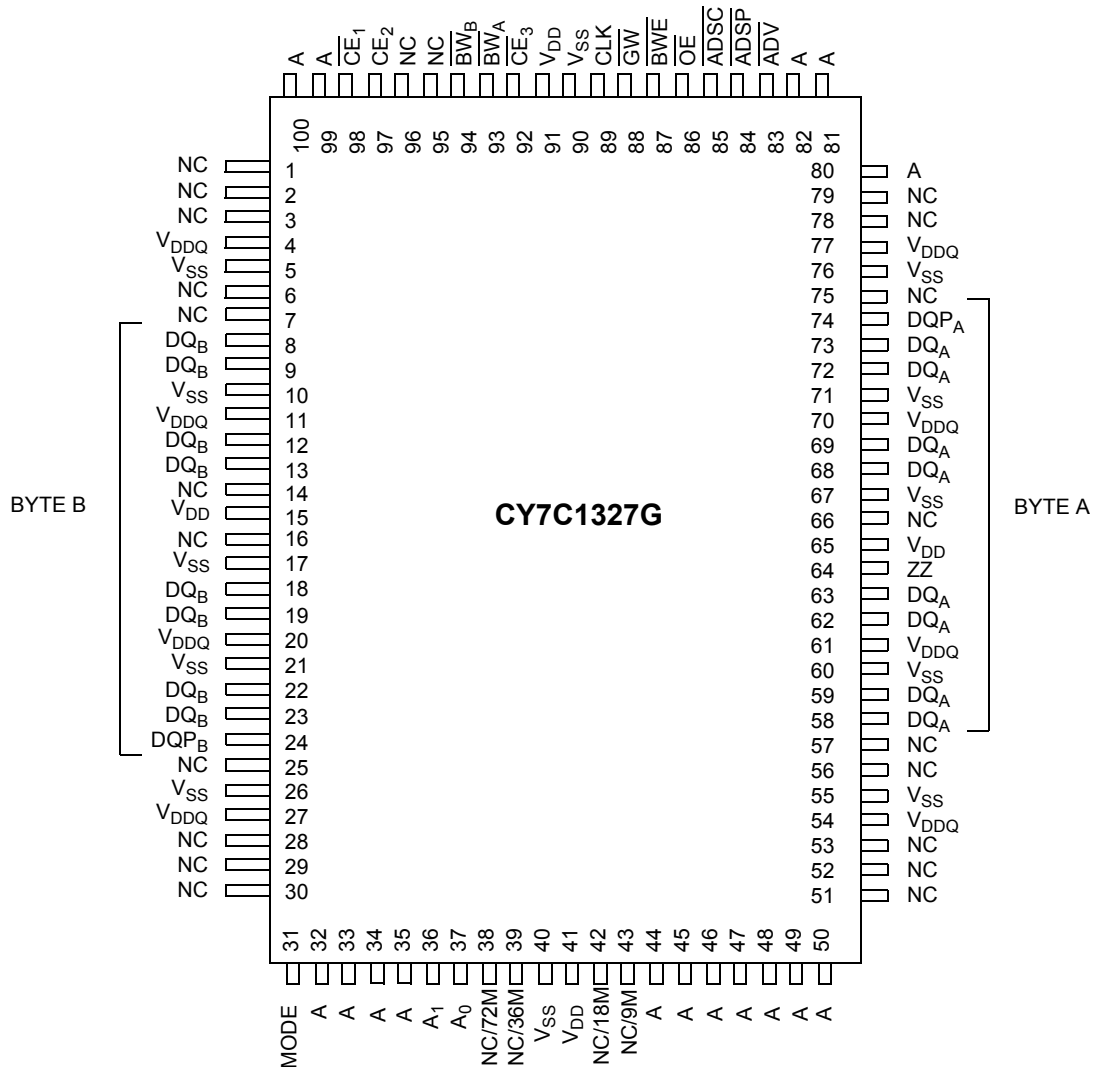

Note

1. **Errata:** The ZZ pin (Pin 64) needs to be externally connected to ground. For more information, see "Errata" on page 20.

Pin Definitions

Name	I/O	Description
A ₀ , A ₁ , A	Input-synchronous	Address inputs used to select one of the 256 K address locations. Sampled at the rising edge of the CLK if ADSP or ADSC is active LOW, and CE ₁ , CE ₂ , and CE ₃ are sampled active. A ₁ , A ₀ feed the 2-bit counter.
BW _A , BW _B	Input-synchronous	Byte write select inputs, active LOW. Qualified with BWE to conduct byte writes to the SRAM. Sampled on the rising edge of CLK.
GW	Input-synchronous	Global write enable input, active LOW. When asserted LOW on the rising edge of CLK, a global write is conducted (all bytes are written, regardless of the values on BW _[A:B] and BWE).
BWE	Input-synchronous	Byte write enable input, active LOW. Sampled on the rising edge of CLK. This signal must be asserted LOW to conduct a byte write.
CLK	Input-clock	Clock input. Used to capture all synchronous inputs to the device. Also used to increment the burst counter when ADV is asserted LOW, during a burst operation.
CE ₁	Input-synchronous	Chip enable 1 input, active LOW. Sampled on the rising edge of CLK. Used in conjunction with CE ₂ and CE ₃ to select/deselect the device. ADSP is ignored if CE ₁ is HIGH. CE ₁ is sampled only when a new external address is loaded.
CE ₂	Input-synchronous	Chip enable 2 input, active HIGH. Sampled on the rising edge of CLK. Used in conjunction with CE ₁ and CE ₃ to select/deselect the device. CE ₂ is sampled only when a new external address is loaded.
CE ₃	Input-synchronous	Chip enable 3 input, active LOW. Sampled on the rising edge of CLK. Used in conjunction with CE ₁ and CE ₂ to select/deselect the device. CE ₃ is sampled only when a new external address is loaded.
OE	Input-asynchronous	Output enable, asynchronous input, active LOW. Controls the direction of the I/O pins. When LOW, the I/O pins behave as outputs. When deasserted HIGH, I/O pins are tristated, and act as input data pins. OE is masked during the first clock of a read cycle when emerging from a deselected state.
ADV	Input-synchronous	Advance input signal, sampled on the rising edge of CLK, active LOW. When asserted, it automatically increments the address in a burst cycle.
ADSP	Input-synchronous	Address strobe from processor, sampled on the rising edge of CLK, active LOW. When asserted LOW, A is captured in the address registers. A ₁ :A ₀ are also loaded into the burst counter. When ADSP and ADSC are both asserted, only ADSP is recognized. ADSP is ignored when CE ₁ is deasserted HIGH.
ZZ ^[2]	Input-asynchronous	ZZ “sleep” input, active HIGH. This input, when High places the device in a non-time-critical “sleep” condition with data integrity preserved. During normal operation, this pin has to be low or left floating. ZZ pin has an internal pull-down.
ADSC	Input-synchronous	Address strobe from controller, sampled on the rising edge of CLK, active LOW. When asserted LOW, A is captured in the address registers. A ₁ :A ₀ are also loaded into the burst counter. When ADSP and ADSC are both asserted, only ADSP is recognized.
DQ _A , DQ _B , DQP _A , DQP _B	I/O-synchronous	Bidirectional data I/O lines. As inputs, they feed into an on-chip data register that is triggered by the rising edge of CLK. As outputs, they deliver the data contained in the memory location specified by “A” during the previous clock rise of the read cycle. The direction of the pins is controlled by OE. When OE is asserted LOW, the pins behave as outputs. When HIGH, DQs and DQP _[A:B] are placed in a tristate condition.
V _{DD}	Power supply	Power supply inputs to the core of the device.
V _{SS}	Ground	Ground for the device.
V _{DDQ}	I/O ground	Ground for the I/O circuitry.
MODE	Input-static	Selects burst order. When tied to GND selects linear burst sequence. When tied to V _{DD} or left floating selects interleaved burst sequence. This is a strap pin and should remain static during device operation. Mode Pin has an internal pull-up.
NC, NC/9M, NC/18M, NC/72M, NC/144M, NC/288M, NC/576M, NC/1G	–	No connects. Not internally connected to the die. NC/9M, NC/18M, NC/72M, NC/144M, NC/288M, NC/576M and NC/1G are address expansion pins are not internally connected to the die.

Note

- Errata:** The ZZ pin (Pin 64) needs to be externally connected to ground. For more information, see “Errata” on page 20.

Functional Overview

All synchronous inputs pass through input registers controlled by the rising edge of the clock. All data outputs pass through output registers controlled by the rising edge of the clock.

The CY7C1327G supports secondary cache in systems utilizing either a linear or interleaved burst sequence. The interleaved burst order supports Pentium and i486™ processors. The linear burst sequence is suited for processors that utilize a linear burst sequence. The burst order is user selectable, and is determined by sampling the MODE input. Accesses can be initiated with either the processor address strobe (ADSP) or the controller address strobe (ADSC). Address advancement through the burst sequence is controlled by the ADV input. A two-bit on-chip wraparound burst counter captures the first address in a burst sequence and automatically increments the address for the rest of the burst access.

Byte write operations are qualified with the byte write enable (BWE) and byte write select ($BW_{[A:B]}$) inputs. A global write enable (GW) overrides all byte write inputs and writes data to all four bytes. All writes are simplified with on-chip synchronous self-timed write circuitry.

Three synchronous chip selects (\overline{CE}_1 , CE_2 , \overline{CE}_3) and an asynchronous output enable (\overline{OE}) provide for easy bank selection and output tristate control. ADSP is ignored if CE_1 is HIGH.

Single Read Accesses

This access is initiated when the following conditions are satisfied at clock rise: (1) ADSP or ADSC is asserted LOW, (2) \overline{CE}_1 , CE_2 , CE_3 are all asserted active, and (3) the write signals (GW, BWE) are all deserted HIGH. ADSP is ignored if CE_1 is HIGH. The address presented to the address inputs (A) is stored into the address advancement logic and the address register while being presented to the memory array. The corresponding data is allowed to propagate to the input of the output registers. At the rising edge of the next clock the data is allowed to propagate through the output register and onto the data bus within t_{CO} if \overline{OE} is active LOW. The only exception occurs when the SRAM is emerging from a deselected state to a selected state, its outputs are always tristated during the first cycle of the access. After the first cycle of the access, the outputs are controlled by the \overline{OE} signal. Consecutive single read cycles are supported. Once the SRAM is deselected at clock rise by the chip select and either ADSP or ADSC signals, its output will tristate immediately.

Single Write Accesses Initiated by ADSP

This access is initiated when both of the following conditions are satisfied at clock rise: (1) ADSP is asserted LOW, and (2) \overline{CE}_1 , CE_2 , CE_3 are all asserted active. The address presented to A is loaded into the address register and the address advancement logic while being delivered to the memory array. The Write signals (GW, BWE, and $BW_{[A:B]}$) and ADV inputs are ignored during this first cycle.

ADSP-triggered Write accesses require two clock cycles to complete. If GW is asserted LOW on the second clock rise, the data presented to the DQ inputs is written into the corresponding address location in the memory array. If GW is HIGH, then the

Write operation is controlled by \overline{BWE} and $\overline{BW}_{[A:B]}$ signals. The CY7C1327G provides byte write capability that is described in the Write Cycle Descriptions table. Asserting the byte write enable input (\overline{BWE}) with the selected byte write ($\overline{BW}_{[A:B]}$) input, will selectively write to only the desired bytes. Bytes not selected during a byte write operation will remain unaltered. A synchronous self-timed Write mechanism has been provided to simplify the write operations.

Because the CY7C1327G is a common I/O device, the output enable (\overline{OE}) must be deserted HIGH before presenting data to the DQ inputs. Doing so will tristate the output drivers. As a safety precaution, DQs are automatically tristated whenever a Write cycle is detected, regardless of the state of \overline{OE} .

Single Write Accesses Initiated by ADSC

ADSC write accesses are initiated when the following conditions are satisfied: (1) ADSC is asserted LOW, (2) ADSP is deserted HIGH, (3) CE_1 , CE_2 , CE_3 are all asserted active, and (4) the appropriate combination of the write inputs (GW, BWE, and $BW_{[A:B]}$) are asserted active to conduct a write to the desired byte(s). ADSC-triggered Write accesses require a single clock cycle to complete. The address presented to A is loaded into the address register and the address advancement logic while being delivered to the memory array. The ADV input is ignored during this cycle. If a global write is conducted, the data presented to DQ is written into the corresponding address location in the memory core. If a byte write is conducted, only the selected bytes are written. Bytes not selected during a byte write operation will remain unaltered. A synchronous self-timed write mechanism has been provided to simplify the write operations.

Because the CY7C1327G is a common I/O device, the output enable (\overline{OE}) must be deserted HIGH before presenting data to the DQ inputs. Doing so will tristate the output drivers. As a safety precaution, DQs are automatically tristated whenever a Write cycle is detected, regardless of the state of \overline{OE} .

Burst Sequences

The CY7C1327G provides a two-bit wraparound counter, fed by A1:A0, that implements either an interleaved or linear burst sequence. The interleaved burst sequence is designed specifically to support Intel Pentium applications. The linear burst sequence is designed to support processors that follow a linear burst sequence. The burst sequence is user selectable through the MODE input.

Asserting \overline{ADV} LOW at clock rise will automatically increment the burst counter to the next address in the burst sequence. Both Read and Write burst operations are supported.

Sleep Mode

The ZZ input pin is an asynchronous input. Asserting ZZ places the SRAM in a power conservation "sleep" mode. Two clock cycles are required to enter into or exit from this "sleep" mode. While in this mode, data integrity is guaranteed. Accesses pending when entering the "sleep" mode are not considered valid nor is the completion of the operation guaranteed. The device must be deselected prior to entering the "sleep" mode. CE_1 , CE_2 , CE_3 , ADSP, and ADSC must remain inactive for the duration of t_{ZZREC} after the ZZ input returns LOW.

Interleaved Burst Address Table

(MODE = Floating or V_{DD})

First Address A1:A0	Second Address A1:A0	Third Address A1:A0	Fourth Address A1:A0
00	01	10	11
01	00	11	10
10	11	00	01
11	10	01	00

Linear Burst Address Table

(MODE = GND)

First Address A1:A0	Second Address A1:A0	Third Address A1:A0	Fourth Address A1:A0
00	01	10	11
01	10	11	00
10	11	00	01
11	00	01	10

ZZ Mode Electrical Characteristics

Parameter	Description	Test Conditions	Min	Max	Unit
I_{DDZZ}	Snooze mode standby current	$ZZ \geq V_{DD} - 0.2 V$	–	40	mA
t_{ZZS}	Device operation to ZZ	$ZZ \geq V_{DD} - 0.2 V$	–	$2t_{CYC}$	ns
t_{ZZREC}	ZZ recovery time	$ZZ \leq 0.2 V$	$2t_{CYC}$	–	ns
t_{ZZI}	ZZ active to snooze current	This parameter is sampled	–	$2t_{CYC}$	ns
t_{RZZI}	ZZ Inactive to exit snooze current	This parameter is sampled	0	–	ns

Truth Table

The Truth Table for CY7C1327G follows. [3, 4, 5, 6, 7]

Next Cycle	Add. Used	\overline{CE}_1	CE_2	\overline{CE}_3	ZZ	\overline{ADSP}	\overline{ADSC}	\overline{ADV}	\overline{OE}	DQ	\overline{WRITE}
Unselected	None	H	X	X	L	X	L	X	X	Tri-state	X
Unselected	None	L	X	H	L	L	X	X	X	Tri-state	X
Unselected	None	L	L	X	L	L	X	X	X	Tri-state	X
Unselected	None	L	X	H	L	H	L	X	X	Tri-state	X
Unselected	None	L	L	X	L	H	L	X	X	Tri-state	X
Begin read	External	L	H	L	L	L	X	X	X	Tri-state	X
Begin read	External	L	H	L	L	H	L	X	X	Tri-state	H
Continue read	Next	X	X	X	L	H	H	L	H	Tri-state	H
Continue read	Next	X	X	X	L	H	H	L	L	DQ	H
Continue read	Next	H	X	X	L	X	H	L	H	Tri-state	H
Continue read	Next	H	X	X	L	X	H	L	L	DQ	H
Suspend read	Current	X	X	X	L	H	H	H	H	Tri-state	H
Suspend read	Current	X	X	X	L	H	H	H	L	DQ	H
Suspend read	Current	H	X	X	L	X	H	H	H	Tri-state	H
Suspend read	Current	H	X	X	L	X	H	H	L	DQ	H
Begin write	Current	X	X	X	L	H	H	H	X	Tri-state	L
Begin write	Current	H	X	X	L	X	H	H	X	Tri-state	L
Begin write	External	L	H	L	L	H	H	X	X	Tri-state	L
Continue write	Next	X	X	X	L	H	H	H	X	Tri-state	L
Continue write	Next	H	X	X	L	X	H	H	X	Tri-state	L
Suspend write	Current	X	X	X	L	H	H	H	X	Tri-state	L
Suspend write	Current	H	X	X	L	X	H	H	X	Tri-state	L
ZZ "sleep"	None	X	X	X	H	X	X	X	X	Tri-state	X

Notes

- X = "Don't Care." H = Logic HIGH, L = Logic LOW.
- \overline{WRITE} = L when any one or more byte write enable signals (\overline{BW}_A , \overline{BW}_B) and \overline{BWE} = L or \overline{GW} = L. \overline{WRITE} = H when all byte write enable signals (\overline{BW}_A , \overline{BW}_B), \overline{BWE} , \overline{GW} = H.
- The DQ pins are controlled by the current cycle and the \overline{OE} signal. \overline{OE} is asynchronous and is not sampled with the clock.
- The SRAM always initiates a read cycle when \overline{ADSP} is asserted, regardless of the state of \overline{GW} , \overline{BWE} , or $\overline{BW}_{[A, B]}$. Writes may occur only on subsequent clocks after the \overline{ADSP} or with the assertion of \overline{ADSC} . As a result, \overline{OE} must be driven HIGH prior to the start of the write cycle to allow the outputs to tristate. \overline{OE} is a don't care for the remainder of the write cycle.
- \overline{OE} is asynchronous and is not sampled with the clock rise. It is masked internally during write cycles. During a read cycle all data bits are tristate when \overline{OE} is inactive or when the device is deselected, and all data bits behave as output when \overline{OE} is active (LOW).

Truth Table for Read/Write

The Truth Table for Read/Write follows. ^[8]

Function	\overline{GW}	\overline{BWE}	\overline{BW}_B	\overline{BW}_A
Read	H	H	X	X
Read	H	L	H	H
Write byte A – (DQ _A and DQP _A)	H	L	H	L
Write byte B – (DQ _B and DQP _B)	H	L	L	H
Write bytes B, A	H	L	L	L
Write all bytes	H	L	L	L
Write all bytes	L	X	X	X

Note

8. X = "Don't Care." H = Logic HIGH, L = Logic LOW.

Maximum Ratings

Exceeding maximum ratings may impair the useful life of the device. These user guidelines are not tested.

Storage temperature	-65 °C to +150 °C
Ambient temperature with power applied	-55 °C to +125 °C
Supply voltage on V _{DD} relative to GND	-0.5 V to +4.6 V
Supply voltage on V _{DDQ} relative to GND	-0.5 V to +V _{DD}
DC voltage applied to outputs in tristate	-0.5 V to V _{DDQ} + 0.5 V
DC input voltage	-0.5 V to V _{DD} + 0.5 V
Current into outputs (LOW)	20 mA
Static discharge voltage (per MIL-STD-883, method 3015)	> 2001 V
Latch-up current	> 200 mA

Operating Range

Range	Ambient Temperature	V _{DD}	V _{DDQ}
Commercial	0 °C to +70 °C	3.3 V - 5% / + 10%	2.5 V - 5% to V _{DD}
Industrial	-40 °C to +85 °C		

Neutron Soft Error Immunity

Parameter	Description	Test Conditions	Typ	Max*	Unit
LSBU	Logical single-bit upsets	25 °C	361	394	FIT/Mb
LMBU	Logical multi-bit upsets	25 °C	0	0.01	FIT/Mb
SEL	Single event latch-up	85 °C	0	0.1	FIT/Dev

* No LMBU or SEL events occurred during testing; this column represents a statistical χ^2 , 95% confidence limit calculation. For more details refer to Application Note AN54908 "Accelerated Neutron SER Testing and Calculation of Terrestrial Failure Rates".

Electrical Characteristics

Over the Operating Range

Parameter ^[9, 10]	Description	Test Conditions	Min	Max	Unit
V _{DD}	Power supply voltage		3.135	3.6	V
V _{DDQ}	I/O supply voltage		2.375	V _{DD}	V
V _{OH}	Output HIGH voltage	for 3.3 V I/O, I _{OH} = -4.0 mA	2.4	-	V
		for 2.5 V I/O, I _{OH} = -1.0 mA	2.0	-	V
V _{OL}	Output LOW voltage	for 3.3 V I/O, I _{OL} = 8.0 mA	-	0.4	V
		for 2.5 V I/O, I _{OL} = 1.0 mA	-	0.4	V
V _{IH}	Input HIGH voltage ^[9.]	for 3.3 V I/O	2.0	V _{DD} + 0.3 V	V
		for 2.5 V I/O	1.7	V _{DD} + 0.3 V	V
V _{IL}	Input LOW voltage ^[9.]	for 3.3 V I/O	-0.3	0.8	V
		for 2.5 V I/O	-0.3	0.7	V
I _X	Input leakage current except ZZ and MODE	GND ≤ V _I ≤ V _{DDQ}	-5	5	μA
		Input = V _{SS}	-30	-	μA
	Input current of MODE	Input = V _{DD}	-	5	μA
		Input = V _{SS}	-5	-	μA
Input current of ZZ	Input = V _{SS}	-	30	μA	
	Input = V _{DD}	-	30	μA	
I _{OZ}	Output leakage current	GND ≤ V _I ≤ V _{DDQ} , output disabled	-5	5	μA

Notes

- Overshoot: V_{IH(AC)} < V_{DD} + 1.5 V (Pulse width less than t_{CYC/2}), undershoot: V_{IL(AC)} > -2 V (Pulse width less than t_{CYC/2}).
- T_{Power-up}: Assumes a linear ramp from 0 V to V_{DD(min)} within 200 ms. During this time V_{IH} < V_{DD} and V_{DDQ} ≤ V_{DD}.

Electrical Characteristics *(continued)*

Over the Operating Range

Parameter ^[9, 10]	Description	Test Conditions	Min	Max	Unit	
I _{DD}	V _{DD} operating supply current	V _{DD} = Max, I _{OUT} = 0 mA, f = f _{MAX} = 1/t _{CYC}	6 ns cycle, 166 MHz	–	240	mA
			7.5 ns cycle, 133 MHz	–	225	mA
I _{SB1}	Automatic CE power-down current – TTL inputs	V _{DD} = Max, device deselected, V _{IN} ≥ V _{IH} or V _{IN} ≤ V _{IL} , f = f _{MAX} = 1/t _{CYC}	6 ns cycle, 166 MHz	–	100	mA
			7.5 ns cycle, 133 MHz	–	90	mA
I _{SB2}	Automatic CE power-down current – CMOS inputs	V _{DD} = Max, device deselected, V _{IN} ≤ 0.3 V or V _{IN} ≥ V _{DDQ} – 0.3 V, f = 0	All speeds	–	40	mA
I _{SB3}	Automatic CE power-down current – CMOS inputs	V _{DD} = Max, device deselected, V _{IN} ≤ 0.3 V or V _{IN} ≥ V _{DDQ} – 0.3 V, f = f _{MAX} = 1/t _{CYC}	6 ns cycle, 166 MHz	–	85	mA
			7.5 ns cycle, 133 MHz	–	75	mA
I _{SB4}	Automatic CE power-down current – TTL inputs	V _{DD} = Max, device deselected, V _{IN} ≥ V _{IH} or V _{IN} ≤ V _{IL} , f = 0	All speeds	–	45	mA

Capacitance

Parameter ^[11]	Description	Test Conditions	100-pin TQFP Max	Unit
C _{IN}	Input capacitance	T _A = 25 °C, f = 1 MHz, V _{DD} = 3.3 V, V _{DDQ} = 3.3 V	5	pF
C _{CLK}	Clock input capacitance		5	pF
C _{I/O}	Input/output capacitance		5	pF

Thermal Resistance

Parameter ^[11]	Description	Test Conditions	100-pin TQFP Package	Unit
θ _{JA}	Thermal resistance (junction to ambient)	Test conditions follow standard test methods and procedures for measuring thermal impedance, per EIA/JESD51.	30.32	°C/W
θ _{JC}	Thermal resistance (junction to case)		6.85	°C/W

Note

11. Tested initially and after any design or process change that may affect these parameters.

AC Test Loads and Waveforms

Figure 2. AC Test Loads and Waveforms

3.3 V I/O Test Load

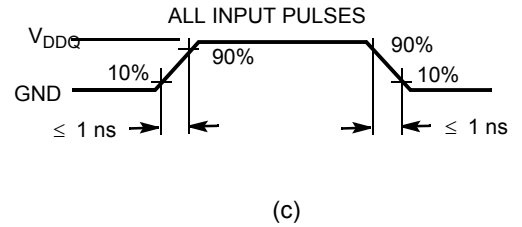
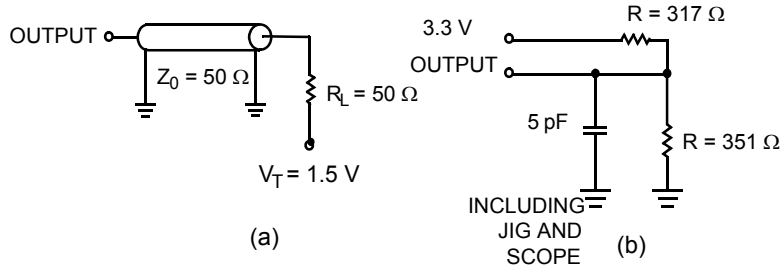

2.5 V I/O Test Load

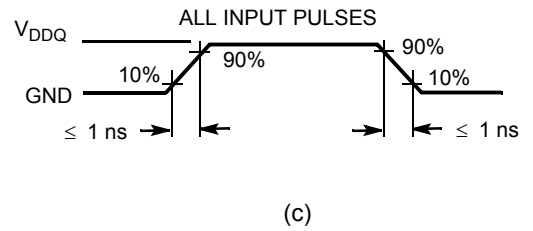
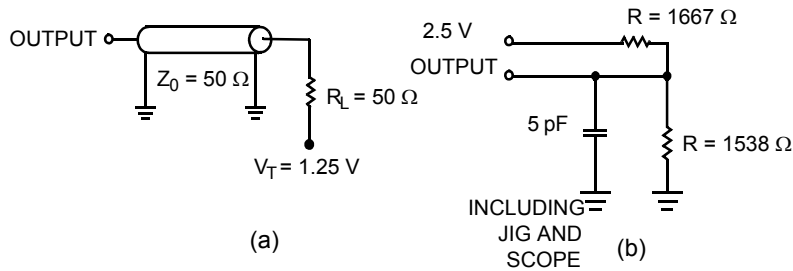

Switching Characteristics

Over the Operating Range

Parameter ^[12, 13]	Description	-166		-133		Unit
		Min	Max	Min	Max	
t _{POWER}	V _{DD} (typical) to the first access ^[14]	1	–	1	–	ms
Clock						
t _{CYC}	Clock cycle time	6.0	–	7.5	–	ns
t _{CH}	Clock HIGH	2.5	–	3.0	–	ns
t _{CL}	Clock LOW	2.5	–	3.0	–	ns
Output Times						
t _{CO}	Data output valid after CLK rise	–	3.5	–	4.0	ns
t _{DOH}	Data output hold after CLK rise	1.5	–	1.5	–	ns
t _{CLZ}	Clock to low Z ^[15, 16, 17]	0	–	0	–	ns
t _{CHZ}	Clock to high Z ^[15, 16, 17]	–	3.5	–	4.0	ns
t _{OEV}	\overline{OE} LOW to output valid	–	3.5	–	4.5	ns
t _{OELZ}	\overline{OE} LOW to output low Z ^[15, 16, 17]	0	–	0	–	ns
t _{OEHZ}	\overline{OE} HIGH to output high Z ^[15, 16, 17]	–	3.5	–	4.0	ns
Set-up Times						
t _{AS}	Address set-up before CLK rise	1.5	–	1.5	–	ns
t _{ADS}	\overline{ADSC} , \overline{ADSP} setup before CLK rise	1.5	–	1.5	–	ns
t _{ADVS}	\overline{ADV} setup before CLK rise	1.5	–	1.5	–	ns
t _{WES}	\overline{GW} , \overline{BWE} , $\overline{BW_X}$ setup before CLK rise	1.5	–	1.5	–	ns
t _{DS}	Data input setup before CLK rise	1.5	–	1.5	–	ns
t _{CES}	Chip enable setup before CLK rise	1.5	–	1.5	–	ns
Hold Times						
t _{AH}	Address hold after CLK rise	0.5	–	0.5	–	ns
t _{ADH}	\overline{ADSP} , \overline{ADSC} hold after CLK rise	0.5	–	0.5	–	ns
t _{ADVH}	\overline{ADV} hold after CLK rise	0.5	–	0.5	–	ns
t _{WEH}	\overline{GW} , \overline{BWE} , $\overline{BW_X}$ hold after CLK rise	0.5	–	0.5	–	ns
t _{DH}	Data input hold after CLK rise	0.5	–	0.5	–	ns
t _{CEH}	Chip enable hold after CLK rise	0.5	–	0.5	–	ns

Notes

12. Timing references level is 1.5 V when V_{DDQ} = 3.3 V and is 1.25 V when V_{DDQ} = 2.5 V on all data sheets.

13. Test conditions shown in (a) of [Figure 2 on page 11](#) unless otherwise noted.

14. This part has a voltage regulator internally; t_{POWER} is the time that the power needs to be supplied above V_{DD(minimum)} initially before a read or write operation can be initiated.

15. t_{CHZ}, t_{CLZ}, t_{OELZ}, and t_{OEHZ} are specified with AC test conditions shown in part (b) of [Figure 2 on page 11](#). Transition is measured ±200 mV from steady-state voltage.

16. At any given voltage and temperature, t_{OEHZ} is less than t_{OELZ} and t_{CHZ} is less than t_{CLZ} to eliminate bus contention between SRAMs when sharing the same data bus. These specifications do not imply a bus contention condition, but reflect parameters guaranteed over worst case user conditions. Device is designed to achieve high Z prior to low Z under the same system conditions.

17. This parameter is sampled and not 100% tested.

Switching Waveforms

Figure 3. Read Cycle Timing [18]

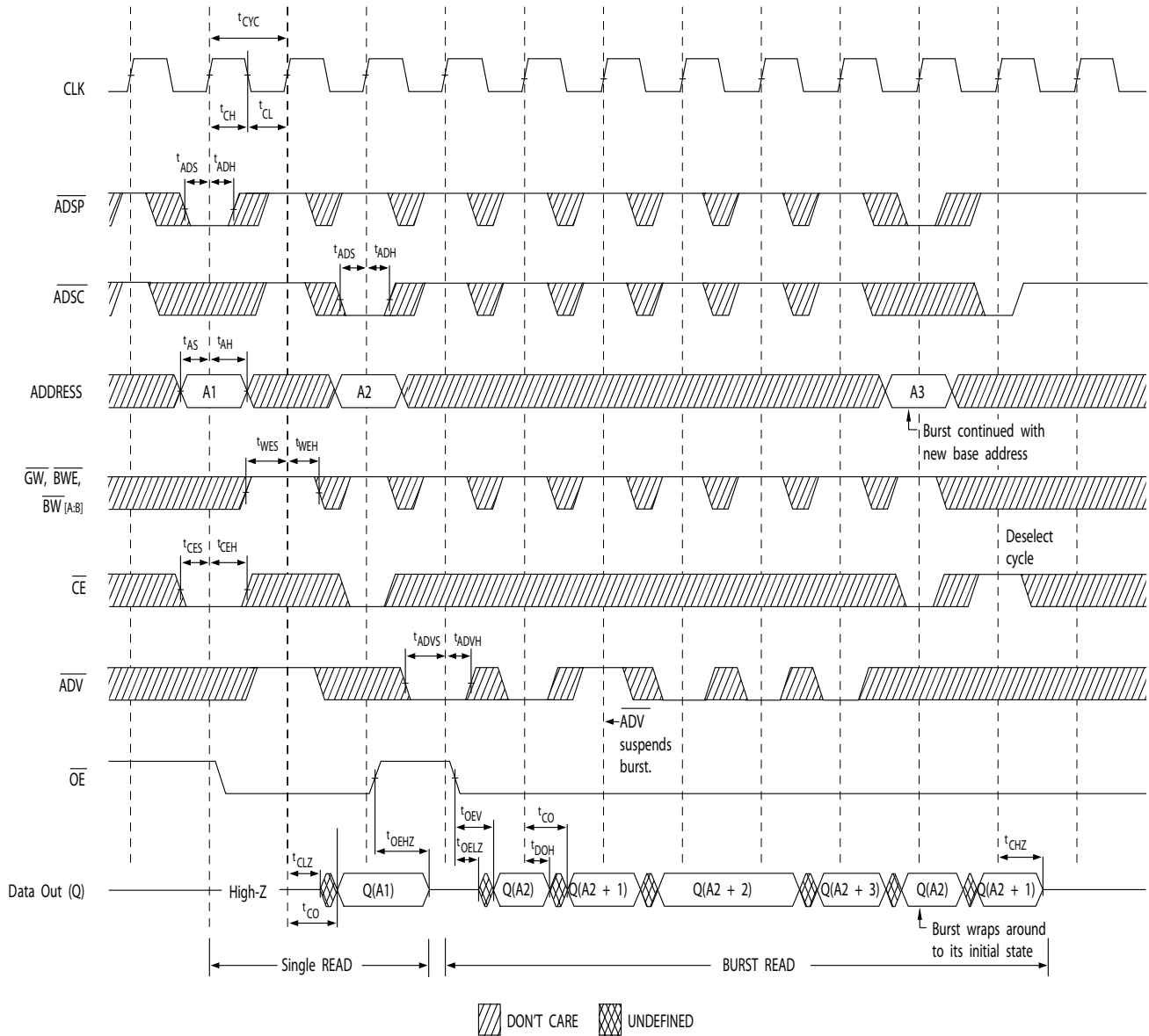

Note

18. On this diagram, when \overline{CE} is LOW: \overline{CE}_1 is LOW, CE_2 is HIGH and \overline{CE}_3 is LOW. When \overline{CE} is HIGH: \overline{CE}_1 is HIGH or CE_2 is LOW or \overline{CE}_3 is HIGH.

Switching Waveforms (continued)

Figure 4. Write Cycle Timing [19, 20]

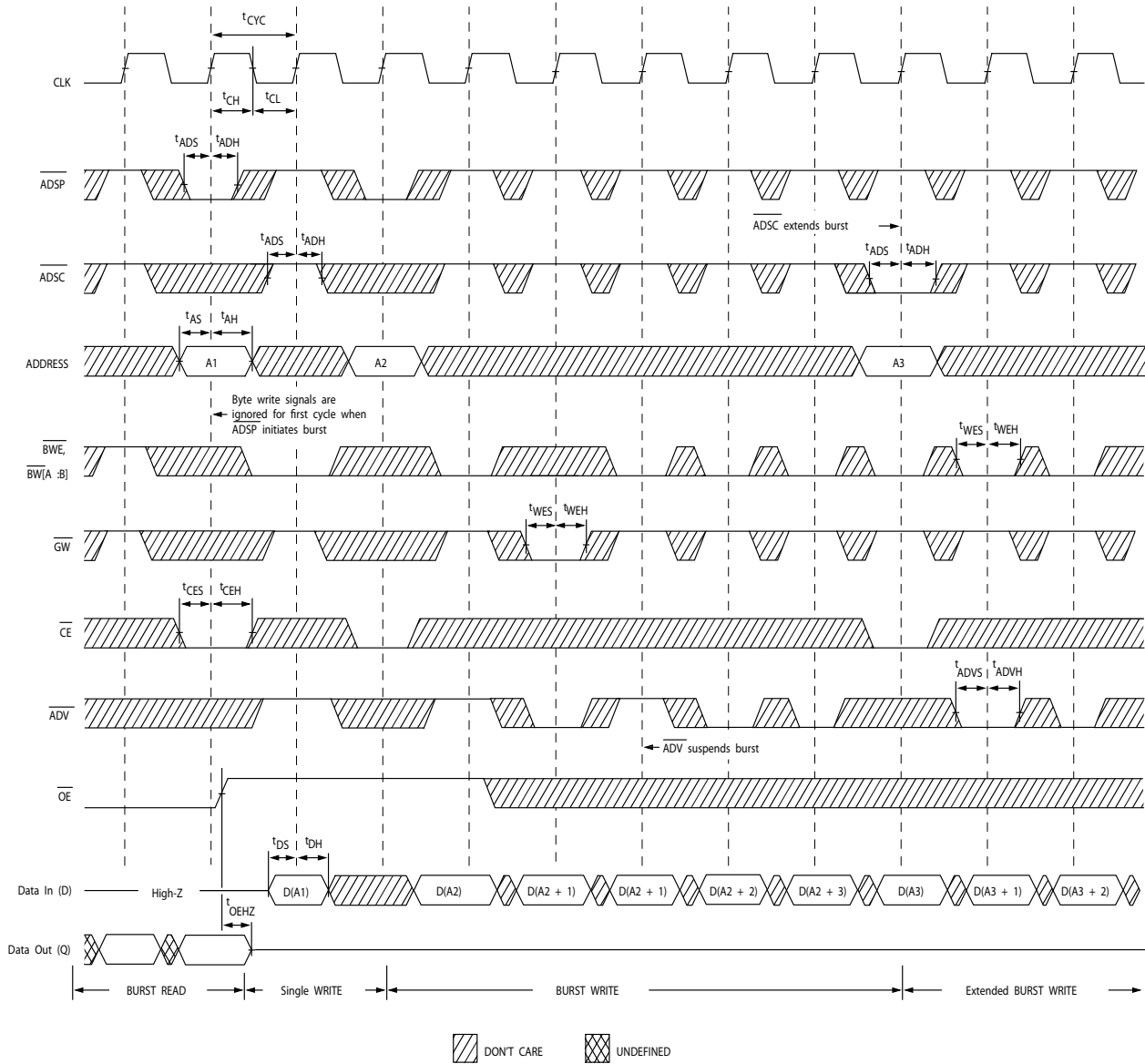

Notes

- 19. On this diagram, when \overline{CE} is LOW: \overline{CE}_1 is LOW, CE_2 is HIGH and \overline{CE}_3 is LOW. When \overline{CE} is HIGH: \overline{CE}_1 is HIGH or CE_2 is LOW or \overline{CE}_3 is HIGH.
- 20. Full width write can be initiated by either \overline{GW} LOW; or by \overline{GW} HIGH, \overline{BWE} LOW and $\overline{BW}_{[A:B]}$ LOW.

Switching Waveforms (continued)

Figure 5. Read/Write Cycle Timing [21, 22, 23]

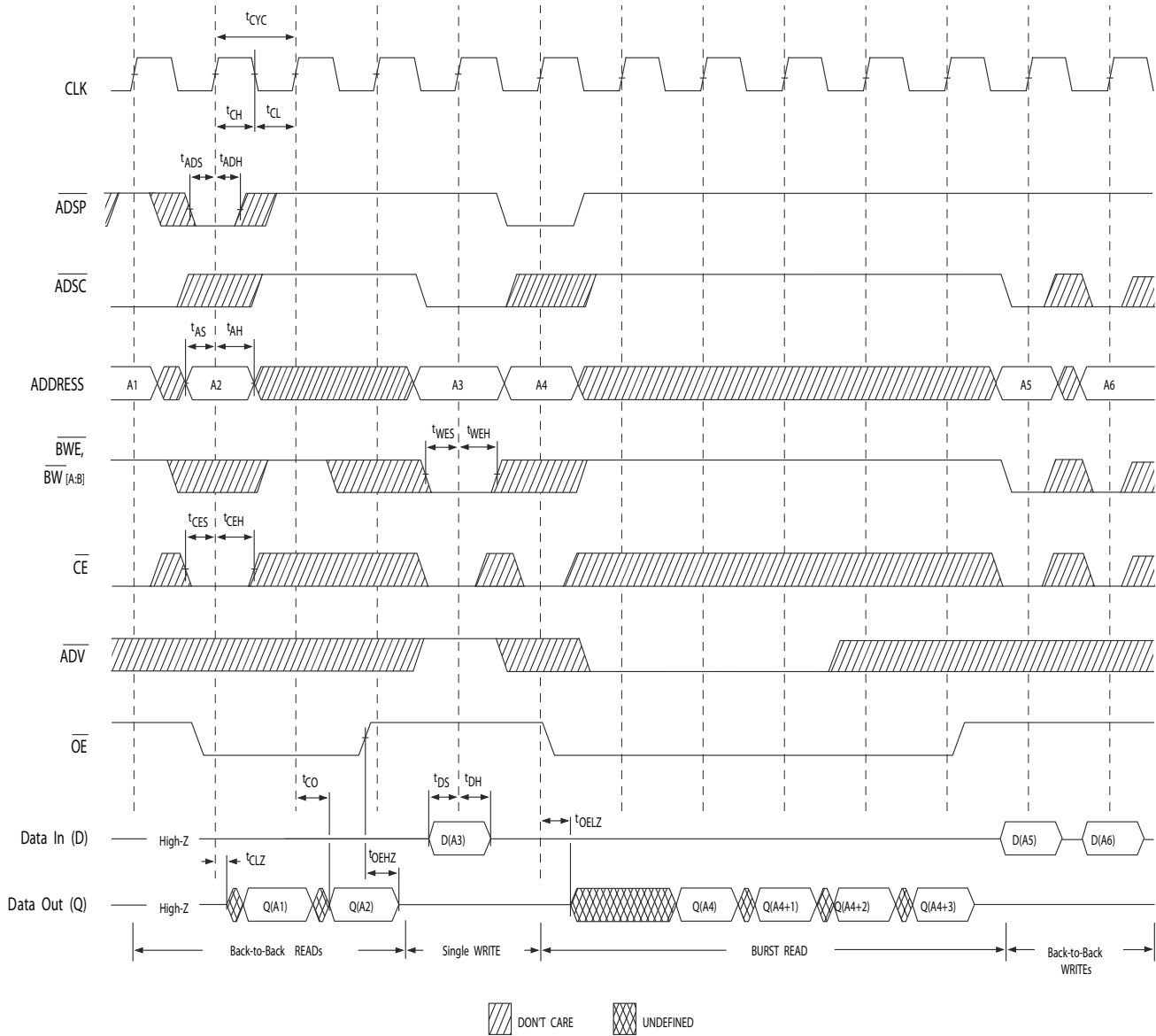

Notes

- 21. On this diagram, when \overline{CE} is LOW: \overline{CE}_1 is LOW, \overline{CE}_2 is HIGH and \overline{CE}_3 is LOW. When \overline{CE} is HIGH: \overline{CE}_1 is HIGH or \overline{CE}_2 is LOW or \overline{CE}_3 is HIGH.
- 22. The data bus (Q) remains in high Z following a WRITE cycle, unless a new read access is initiated by ADSP or ADSC.
- 23. GW is HIGH.

Switching Waveforms (continued)

Figure 6. ZZ Mode Timing [24, 25]

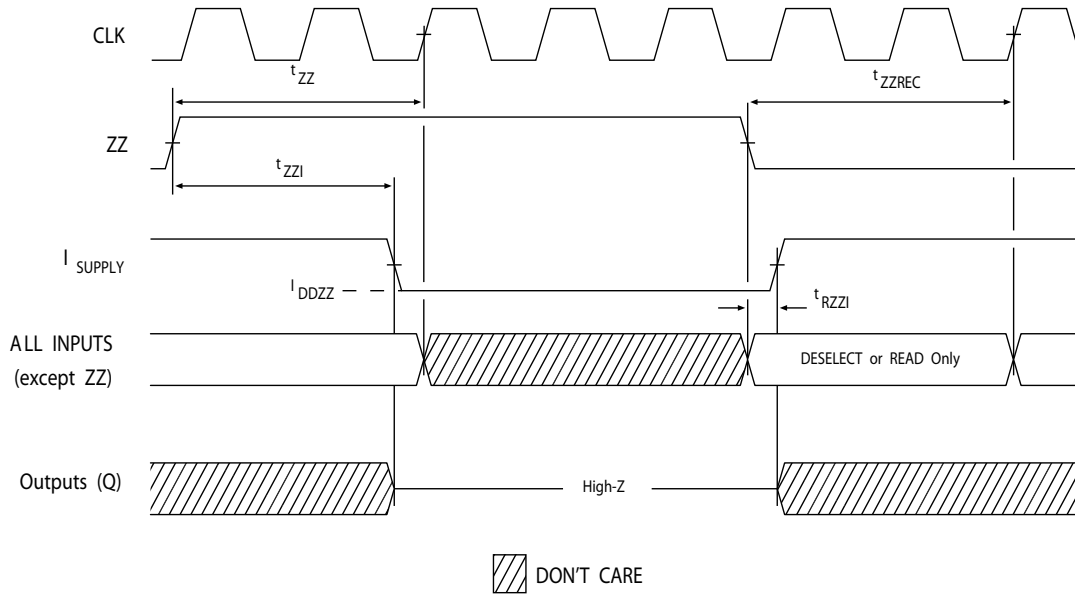

Notes

- 24. Device must be deselected when entering ZZ mode. See Cycle Descriptions table for all possible signal conditions to deselect the device.
- 25. DQs are in high Z when exiting ZZ sleep mode.

Ordering Information

The table below contains only the parts that are currently available. If you don't see what you are looking for, please contact your local sales representative. For more information, visit the Cypress website at www.cypress.com and refer to the product summary page at <http://www.cypress.com/products>

Cypress maintains a worldwide network of offices, solution centers, manufacturer's representatives and distributors. To find the office closest to you, visit us at <http://www.cypress.com/go/datasheet/offices>

Speed (MHz)	Ordering Code	Package Diagram	Package Type	Operating Range
133	CY7C1327G-133AXI	51-85050	100-pin TQFP (14 × 20 × 1.4 mm) Pb-free	Industrial
166	CY7C1327G-166AXC	51-85050	100-pin TQFP (14 × 20 × 1.4 mm) Pb-free	Commercial

Ordering Code Definitions

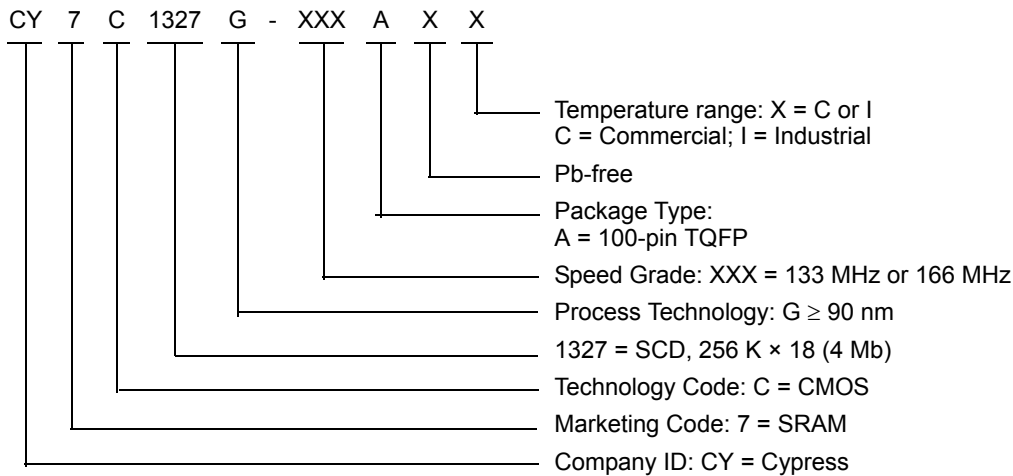

Package Diagrams

Figure 7. 100-pin TQFP (14 × 20 × 1.4 mm) A100RA Package Outline, 51-85050

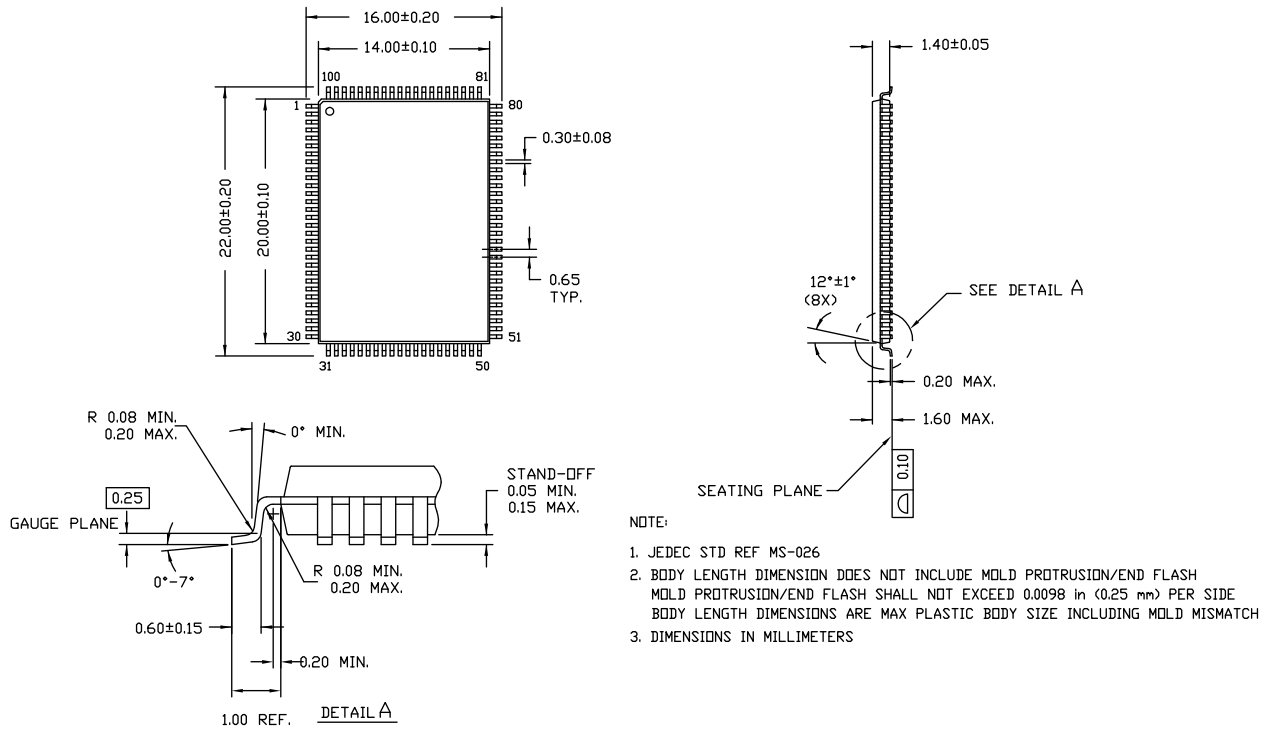

51-85050 *D

Acronyms

Acronym	Description
CE	Chip Enable
CMOS	Complementary Metal Oxide Semiconductor
EIA	Electronic Industries Alliance
I/O	Input/Output
JEDEC	Joint Electron Devices Engineering Council
LMBU	Logical Multi-Bit Upsets
LSBU	Logical Single-Bit Upsets
\overline{OE}	Output Enable
SEL	Single Event Latch-Up
SRAM	Static Random Access Memory
TQFP	Thin Quad Flat Pack
TTL	Transistor-Transistor Logic

Document Conventions

Units of Measure

Symbol	Unit of Measure
°C	degree Celsius
MHz	megahertz
μA	microampere
mA	milliampere
ms	millisecond
mm	millimeter
mV	millivolt
nm	nanometer
ns	nanosecond
Ω	ohm
%	percent
pF	picofarad
V	volt
W	watt

Errata

This section describes the Ram9 Sync/NoBL ZZ pin, JTAG and Chip Enable issues. Details include trigger conditions, the devices affected, proposed workaround and silicon revision applicability. Please contact your local Cypress sales representative if you have further questions.

Part Numbers Affected

Density & Revision	Package Type	Operating Range
4Mb-Ram9 Synchronous SRAMs: CY7C132*G	All packages	Commercial/ Industrial

Product Status

All of the devices in the Ram9 4Mb Sync/NoBL family are qualified and available in production quantities.

Ram9 Sync/NoBL ZZ Pin Issues Errata Summary

The following table defines the errata applicable to available Ram9 4Mb Sync/NoBL family devices.

Item	Issues	Description	Device	Fix Status
1.	ZZ Pin	When asserted HIGH, the ZZ pin places device in a "sleep" condition with data integrity preserved. The ZZ pin currently does not have an internal pull-down resistor and hence cannot be left floating externally by the user during normal mode of operation.	4M-Ram9 (90nm)	For the 4M Ram9 (90 nm) devices, there is no plan to fix this issue.

1. ZZ Pin Issue

■ PROBLEM DEFINITION

The problem occurs only when the device is operated in the normal mode with ZZ pin left floating. The ZZ pin on the SRAM device does not have an internal pull-down resistor. Switching noise in the system may cause the SRAM to recognize a HIGH on the ZZ input, which may cause the SRAM to enter sleep mode. This could result in incorrect or undesirable operation of the SRAM.

■ TRIGGER CONDITIONS

Device operated with ZZ pin left floating.

■ SCOPE OF IMPACT

When the ZZ pin is left floating, the device delivers incorrect data.

■ WORKAROUND

Tie the ZZ pin externally to ground.

■ FIX STATUS

Fix was done for the 72Mb RAM9 Synchronous SRAMs and 72M RAM9 NoBL SRAMs devices. Fixed devices have a new revision. The following table lists the devices affected and the new revision after the fix.

Document History Page

Document Title: CY7C1327G, 4-Mbit (256 K × 18) Pipelined Sync SRAM Document Number: 38-05519				
Rev.	ECN No.	Submission Date	Orig. of Change	Description of Change
**	224367	See ECN	RKF	New data sheet.
*A	278513	See ECN	VBL	Updated Ordering Information (Updated part numbers (Changed TQFP to Pb-free TQFP, added PB-free BGA packages)).
*B	332895	See ECN	SYT	Updated Features (Removed 225 MHz, 100 MHz frequencies related information). Updated Selection Guide (Removed 225 MHz, 100 MHz frequencies related information). Updated Pin Configurations (Modified Address Expansion balls in the pinouts for 100-pin TQFP and 119-ball BGA Packages as per JEDEC standards). Updated Pin Definitions . Updated Electrical Characteristics (Removed 225 MHz, 100 MHz frequencies related information, updated Test Conditions of V_{OL} and V_{OH} parameters). Updated Thermal Resistance (Replaced values of θ_{JA} and θ_{JC} parameters from TBD to respective Thermal Values for all packages). Updated Switching Characteristics (Removed 225 MHz, 100 MHz frequencies related information). Updated Ordering Information (By shading and unshading MPNs as per availability, removed comment on the availability of BGA lead-free package).
*C	351194	See ECN	PCI	Updated Ordering Information (Updated part numbers).
*D	366728	See ECN	PCI	Updated Electrical Characteristics (Added test conditions for V_{DD} and V_{DDQ} parameters, updated Note 10 (Replaced $V_{IH} \leq V_{DD}$ with $V_{IH} < V_{DD}$)).
*E	419256	See ECN	R XU	Changed status from Preliminary to Final. Changed address of Cypress Semiconductor Corporation from “3901 North First Street” to “198 Champion Court”. Updated Electrical Characteristics (Changed “Input Load Current except ZZ and MODE” to “Input Leakage Current except ZZ and MODE” in the description of I_x parameter). Updated Ordering Information (Updated part numbers, replaced Package Name column with Package Diagram in the Ordering Information table). Updated Package Diagrams (spec 51-85050 (changed revision from *A to *B)).
*F	480124	See ECN	VKN	Updated Maximum Ratings (Added the Maximum Rating for Supply Voltage on V_{DDQ} Relative to GND). Updated Ordering Information (Updated part numbers).
*G	2756340	08/26/2009	VKN/AESA	Added Neutron Soft Error Immunity . Updated Ordering Information (By including parts that are available, and modified the disclaimer for the Ordering information).
*H	3044512	10/01/2010	NJY	Added Ordering Code Definitions . Updated Package Diagrams . Added Acronyms and Units of Measure . Minor edits and updated in new template.
*I	3363203	09/05/2011	PRIT	Updated Package Diagrams . Updated in new template.

Document History Page *(continued)*

Document Title: CY7C1327G, 4-Mbit (256 K × 18) Pipelined Sync SRAM Document Number: 38-05519				
Rev.	ECN No.	Submission Date	Orig. of Change	Description of Change
*J	3612268	05/09/2012	PRIT	Updated Features (Removed 250 MHz, 200 MHz frequencies related information, removed 119-ball BGA package related information). Updated Functional Description (Removed the Note “For best practices recommendations, refer to the Cypress application note <i>System Design Guidelines</i> on www.cypress.com .” and its reference). Updated Selection Guide (Removed 250 MHz, 200 MHz frequencies related information). Updated Pin Configurations (Removed 119-ball BGA package related information). Updated Electrical Characteristics (Removed 250 MHz, 200 MHz frequencies related information). Updated Capacitance (Removed 119-ball BGA package related information). Updated Thermal Resistance (Removed 119-ball BGA package related information). Updated Switching Characteristics (Removed 250 MHz, 200 MHz frequencies related information).
*K	3749841	09/20/2012	PRIT	No technical updates. Completing sunset review.
*L	3984870	05/02/2013	PRIT	Added Errata .
*M	4039228	06/25/2013	PRIT	Added Errata Footnotes. Updated in new template.

Sales, Solutions, and Legal Information

Worldwide Sales and Design Support

Cypress maintains a worldwide network of offices, solution centers, manufacturer's representatives, and distributors. To find the office closest to you, visit us at [Cypress Locations](#).

Products

Automotive	cypress.com/go/automotive
Clocks & Buffers	cypress.com/go/clocks
Interface	cypress.com/go/interface
Lighting & Power Control	cypress.com/go/powerpsoc cypress.com/go/plc
Memory	cypress.com/go/memory
PSoC	cypress.com/go/psoc
Touch Sensing	cypress.com/go/touch
USB Controllers	cypress.com/go/USB
Wireless/RF	cypress.com/go/wireless

PSoC[®] Solutions

psoc.cypress.com/solutions
PSoC 1 | PSoC 3 | PSoC 4 | PSoC 5LP

Cypress Developer Community

[Community](#) | [Forums](#) | [Blogs](#) | [Video](#) | [Training](#)

Technical Support

cypress.com/go/support

© Cypress Semiconductor Corporation, 2004-2013. The information contained herein is subject to change without notice. Cypress Semiconductor Corporation assumes no responsibility for the use of any circuitry other than circuitry embodied in a Cypress product. Nor does it convey or imply any license under patent or other rights. Cypress products are not warranted nor intended to be used for medical, life support, life saving, critical control or safety applications, unless pursuant to an express written agreement with Cypress. Furthermore, Cypress does not authorize its products for use as critical components in life-support systems where a malfunction or failure may reasonably be expected to result in significant injury to the user. The inclusion of Cypress products in life-support systems application implies that the manufacturer assumes all risk of such use and in doing so indemnifies Cypress against all charges.

Any Source Code (software and/or firmware) is owned by Cypress Semiconductor Corporation (Cypress) and is protected by and subject to worldwide patent protection (United States and foreign), United States copyright laws and international treaty provisions. Cypress hereby grants to licensee a personal, non-exclusive, non-transferable license to copy, use, modify, create derivative works of, and compile the Cypress Source Code and derivative works for the sole purpose of creating custom software and or firmware in support of licensee product to be used only in conjunction with a Cypress integrated circuit as specified in the applicable agreement. Any reproduction, modification, translation, compilation, or representation of this Source Code except as specified above is prohibited without the express written permission of Cypress.

Disclaimer: CYPRESS MAKES NO WARRANTY OF ANY KIND, EXPRESS OR IMPLIED, WITH REGARD TO THIS MATERIAL, INCLUDING, BUT NOT LIMITED TO, THE IMPLIED WARRANTIES OF MERCHANTABILITY AND FITNESS FOR A PARTICULAR PURPOSE. Cypress reserves the right to make changes without further notice to the materials described herein. Cypress does not assume any liability arising out of the application or use of any product or circuit described herein. Cypress does not authorize its products for use as critical components in life-support systems where a malfunction or failure may reasonably be expected to result in significant injury to the user. The inclusion of Cypress' product in a life-support systems application implies that the manufacturer assumes all risk of such use and in doing so indemnifies Cypress against all charges.

Use may be limited by and subject to the applicable Cypress software license agreement.