



## 4-Mbit (256K words × 16 bit) Static RAM with Error-Correcting Code (ECC)

### Features

- High speed
  - $t_{AA} = 10 \text{ ns} / 15 \text{ ns}$
- Embedded ECC for single-bit error correction<sup>[1]</sup>
- Low active and standby currents
  - Active current:  $I_{CC} = 38\text{-mA}$  typical
  - Standby current:  $I_{SB2} = 6\text{-mA}$  typical
- Operating voltage range: 1.65 V to 2.2 V, 2.2 V to 3.6 V, and 4.5 V to 5.5 V
- 1.0-V data retention
- TTL-compatible inputs and outputs
- Error indication (ERR) pin to indicate 1-bit error detection and correction
- Pb-free 44-pin SOJ, 44-pin TSOP II, and 48-ball VFBGA packages

### Functional Description

CY7C1041G and CY7C1041GE are high-performance CMOS fast static RAM devices with embedded ECC. Both devices are offered in single and dual chip-enable options and in multiple pin configurations. The CY7C1041GE device includes an ERR pin that signals an error-detection and correction event during a read cycle.

Data writes are performed by asserting the Chip Enable ( $\overline{CE}$ ) and Write Enable ( $\overline{WE}$ ) inputs LOW, while providing the data on I/O<sub>0</sub> through I/O<sub>15</sub> and address on A<sub>0</sub> through A<sub>17</sub> pins. The Byte High Enable ( $\overline{BHE}$ ) and Byte Low Enable ( $\overline{BLE}$ ) inputs control write operations to the upper and lower bytes of the specified memory location.  $\overline{BHE}$  controls I/O<sub>8</sub> through I/O<sub>15</sub> and  $\overline{BLE}$  controls I/O<sub>0</sub> through I/O<sub>7</sub>.

Data reads are performed by asserting the Chip Enable ( $\overline{CE}$ ) and Output Enable ( $\overline{OE}$ ) inputs LOW and providing the required address on the address lines. Read data is accessible on the I/O lines (I/O<sub>0</sub> through I/O<sub>15</sub>). Byte accesses can be performed by asserting the required byte enable signal ( $\overline{BHE}$  or  $\overline{BLE}$ ) to read either the upper byte or the lower byte of data from the specified address location.

All I/Os (I/O<sub>0</sub> through I/O<sub>15</sub>) are placed in a high-impedance state during the following events:

- The device is deselected ( $\overline{CE}$  HIGH)
- The control signals ( $\overline{OE}$ ,  $\overline{BLE}$ ,  $\overline{BHE}$ ) are de-asserted

On the CY7C1041GE devices, the detection and correction of a single-bit error in the accessed location is indicated by the assertion of the ERR output (ERR = HIGH)<sup>[1]</sup>. See the [Truth Table on page 14](#) for a complete description of read and write modes.

The logic block diagram is on page 2.

### Product Portfolio

Product <sup>[2]</sup>	Features and Options (see <a href="#">Pin Configurations on page 4</a> )	Range	V <sub>CC</sub> Range (V)	Speed (ns) 10/15	Power Dissipation			
					Operating I <sub>CC</sub> (mA)		Standby, I <sub>SB2</sub> (mA)	
					f = f <sub>max</sub>			
					Typ <sup>[3]</sup>	Max	Typ <sup>[3]</sup>	Max
CY7C1041G(E)18	Single or Dual Chip Enables Optional ERR pins	Industrial	1.65 V–2.2 V	15	–	40	6	8
CY7C1041G(E)30			2.2 V–3.6 V	10	38	45		
CY7C1041G(E)			4.5 V–5.5 V	10	38	45		

#### Notes

1. This device does not support automatic write-back on error detection.
2. The ERR pin is available only for devices which have ERR option "E" in the ordering code. Refer [Ordering Information on page 15](#) for details.
3. Typical values are included only for reference and are not guaranteed or tested. Typical values are measured at V<sub>CC</sub> = 1.8 V (for a V<sub>CC</sub> range of 1.65 V–2.2 V), V<sub>CC</sub> = 3 V (for a V<sub>CC</sub> range of 2.2 V–3.6 V), and V<sub>CC</sub> = 5 V (for a V<sub>CC</sub> range of 4.5 V–5.5 V), T<sub>A</sub> = 25 °C.

**Logic Block Diagram – CY7C1041G**

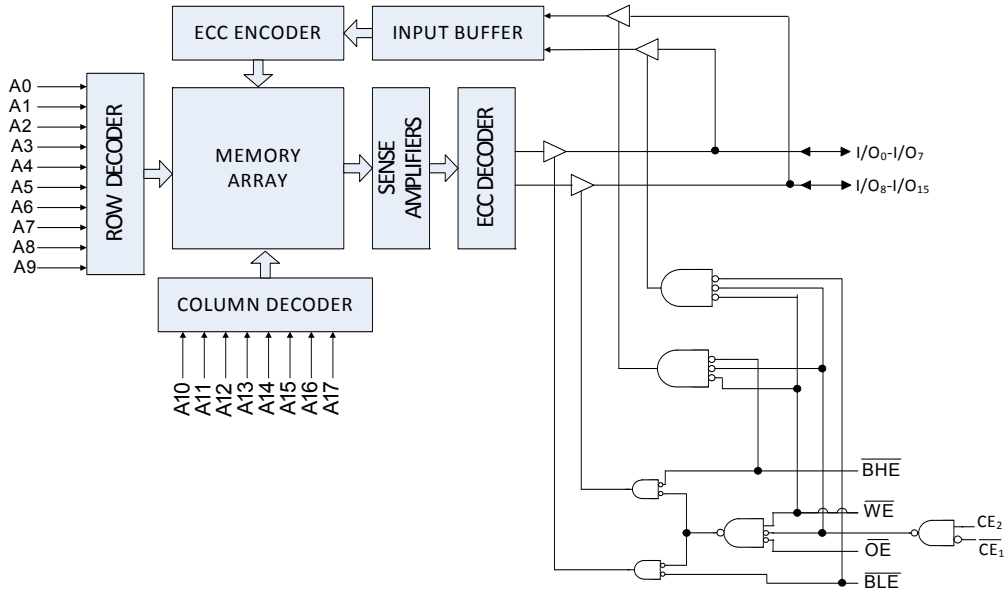

**Logic Block Diagram – CY7C1041GE**

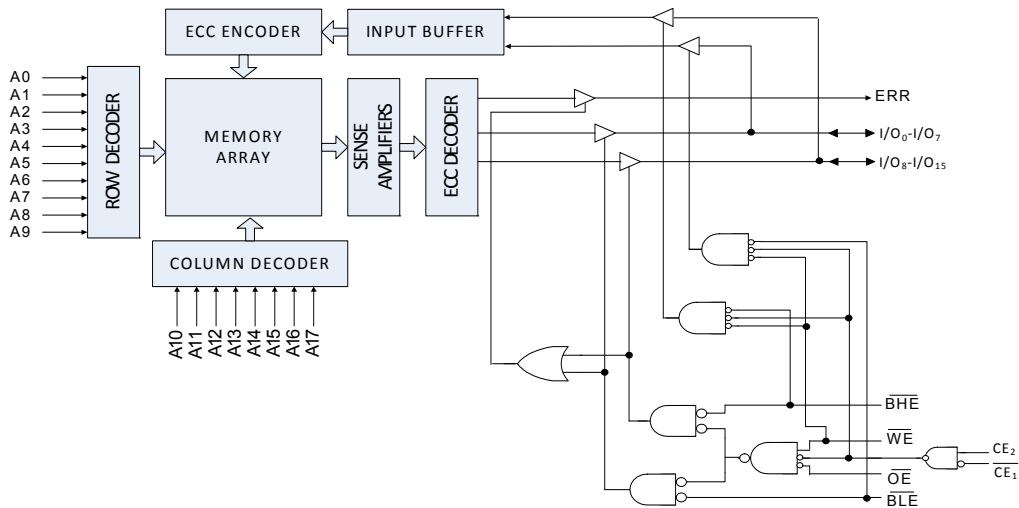

## Contents

<b>Pin Configurations</b> .....	<b>4</b>	<b>Ordering Information</b> .....	<b>15</b>
<b>Maximum Ratings</b> .....	<b>6</b>	Ordering Code Definitions .....	15
<b>Operating Range</b> .....	<b>6</b>	<b>Package Diagrams</b> .....	<b>16</b>
<b>DC Electrical Characteristics</b> .....	<b>6</b>	<b>Acronyms</b> .....	<b>18</b>
<b>Capacitance</b> .....	<b>7</b>	<b>Document Conventions</b> .....	<b>18</b>
<b>Thermal Resistance</b> .....	<b>7</b>	Units of Measure .....	18
<b>AC Test Loads and Waveforms</b> .....	<b>7</b>	<b>Document History Page</b> .....	<b>19</b>
<b>Data Retention Characteristics</b> .....	<b>8</b>	<b>Sales, Solutions, and Legal Information</b> .....	<b>20</b>
<b>Data Retention Waveform</b> .....	<b>8</b>	Worldwide Sales and Design Support .....	20
<b>AC Switching Characteristics</b> .....	<b>9</b>	Products .....	20
<b>Switching Waveforms</b> .....	<b>10</b>	PSoC® Solutions .....	20
<b>Truth Table</b> .....	<b>14</b>	Cypress Developer Community .....	20
<b>ERR Output – CY7C1041GE</b> .....	<b>14</b>	Technical Support .....	20

## Pin Configurations

**Figure 1. 48-ball VFBGA (6 × 8 × 1.0 mm) Single Chip Enable without ERR, CY7C1041G<sup>[4]</sup>, Package/Grade ID: BVXI<sup>[6]</sup>**      **Figure 2. 48-ball VFBGA (6 × 8 × 1.0 mm) Single Chip Enable with ERR, CY7C1041GE<sup>[4, 5]</sup>, Package/Grade ID: BVXI<sup>[6]</sup>**

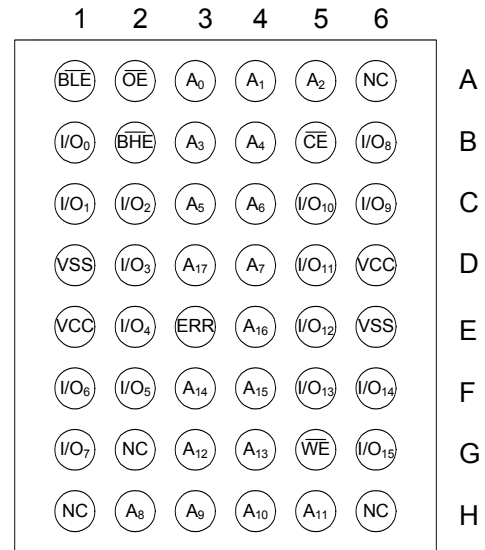
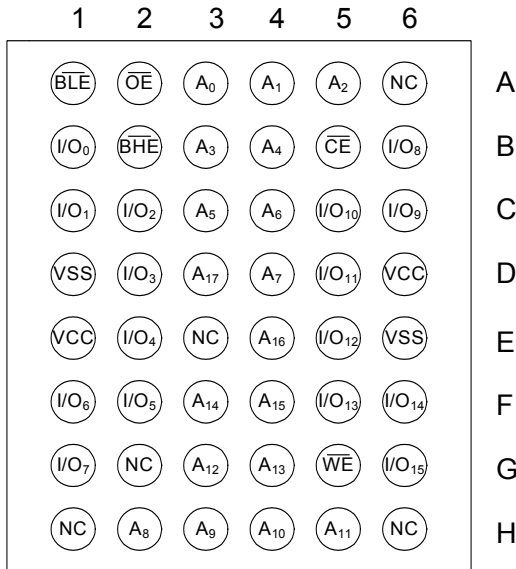

**Figure 3. 48-ball VFBGA (6 × 8 × 1.0 mm) Single Chip Enable without ERR, CY7C1041G<sup>[4]</sup>, Package/Grade ID: BVJXI<sup>[6]</sup>**

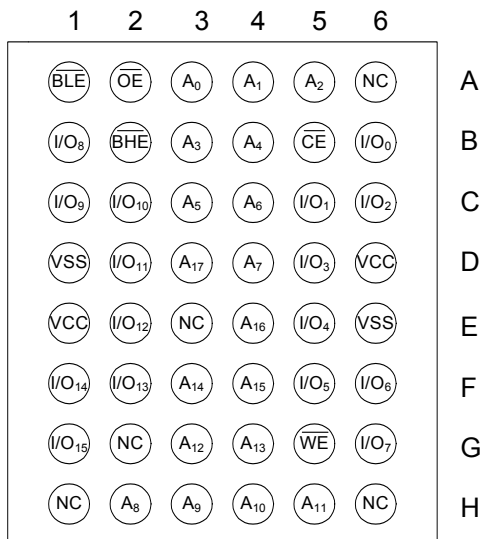

**Figure 4. 48-ball VFBGA (6 × 8 × 1.0 mm) Single Chip Enable with ERR, CY7C1041GE<sup>[4, 5]</sup>, Package/Grade ID: BVJXI<sup>[6]</sup>**

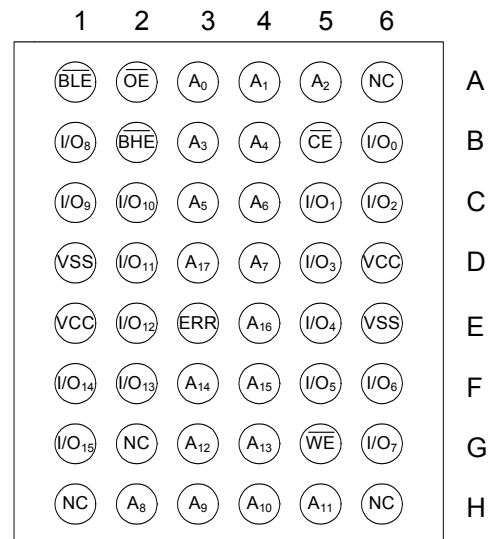

### Notes

- NC pins are not connected internally to the die.
- ERR is an output pin.
- Package type BVJXI is JEDEC compliant compared to package type BVXI. The difference between the two is that the higher and lower byte I/Os (I/O<sub>[7:0]</sub> and I/O<sub>[15:8]</sub>) balls are swapped.

**Pin Configurations** (continued)

**Figure 5. 44-pin TSOP II/44-pin SOJ Single Chip Enable with ERR, CY7C1041GE [7, 8]**

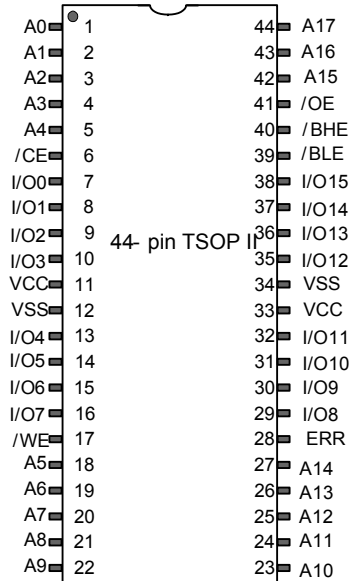

**Figure 6. 44-pin TSOP II/44-pin SOJ Single Chip Enable without ERR, CY7C1041G [7]**

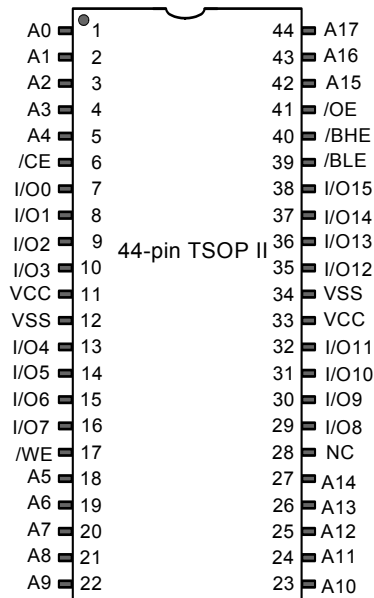

**Notes**

- 7. NC pins are not connected internally to the die.
- 8. ERR is an output pin.

## Maximum Ratings

Exceeding maximum ratings may impair the useful life of the device. These user guidelines are not tested.

Storage temperature ..... -65 °C to +150 °C

Ambient temperature  
with power applied ..... -55 °C to +125 °C

Supply voltage  
on V<sub>CC</sub> relative to GND <sup>[9]</sup> ..... -0.5 V to V<sub>CC</sub> + 0.5 V

DC voltage applied to outputs  
in HI-Z State <sup>[9]</sup> ..... -0.5 V to V<sub>CC</sub> + 0.5 V

DC input voltage <sup>[9]</sup> ..... -0.5 V to V<sub>CC</sub> + 0.5 V

Current into outputs (in LOW state) ..... 20 mA

Static discharge voltage  
(MIL-STD-883, Method 3015) ..... > 2001 V

Latch-up current ..... > 140 mA

## Operating Range

Grade	Ambient Temperature	V <sub>CC</sub>
Industrial	-40 °C to +85 °C	1.65 V to 2.2 V, 2.2 V to 3.6 V, 4.5 V to 5.5 V

## DC Electrical Characteristics

Over the operating range of -40 °C to 85 °C

Parameter	Description	Test Conditions	10 ns / 15 ns			Unit	
			Min	Typ <sup>[10]</sup>	Max		
V <sub>OH</sub>	Output HIGH voltage	1.65 V to 2.2 V	V <sub>CC</sub> = Min, I <sub>OH</sub> = -0.1 mA	1.4	-	-	V
		2.2 V to 2.7 V	V <sub>CC</sub> = Min, I <sub>OH</sub> = -1.0 mA	2	-	-	
		2.7 V to 3.6 V	V <sub>CC</sub> = Min, I <sub>OH</sub> = -4.0 mA	2.2	-	-	
		4.5 V to 5.5 V	V <sub>CC</sub> = Min, I <sub>OH</sub> = -4.0 mA	2.4	-	-	
		4.5 V to 5.5 V	V <sub>CC</sub> = Min, I <sub>OH</sub> = -0.1 mA	V <sub>CC</sub> - 0.5 <sup>[11]</sup>	-	-	
V <sub>OL</sub>	Output LOW voltage	1.65 V to 2.2 V	V <sub>CC</sub> = Min, I <sub>OL</sub> = 0.1 mA	-	-	0.2	V
		2.2 V to 2.7 V	V <sub>CC</sub> = Min, I <sub>OL</sub> = 2 mA	-	-	0.4	
		2.7 V to 3.6 V	V <sub>CC</sub> = Min, I <sub>OL</sub> = 8 mA	-	-	0.4	
		4.5 V to 5.5 V	V <sub>CC</sub> = Min, I <sub>OL</sub> = 8 mA	-	-	0.4	
V <sub>IH</sub>	Input HIGH voltage	1.65 V to 2.2 V	-	1.4	-	V <sub>CC</sub> + 0.2 <sup>[9]</sup>	V
		2.2 V to 2.7 V	-	2	-	V <sub>CC</sub> + 0.3 <sup>[9]</sup>	
		2.7 V to 3.6 V	-	2	-	V <sub>CC</sub> + 0.3 <sup>[9]</sup>	
		4.5 V to 5.5 V	-	2.2	-	V <sub>CC</sub> + 0.5 <sup>[9]</sup>	
V <sub>IL</sub>	Input LOW voltage	1.65 V to 2.2 V	-	-0.2 <sup>[9]</sup>	-	0.4	V
		2.2 V to 2.7 V	-	-0.3 <sup>[9]</sup>	-	0.6	
		2.7 V to 3.6 V	-	-0.3 <sup>[9]</sup>	-	0.8	
		4.5 V to 5.5 V	-	-0.5 <sup>[9]</sup>	-	0.8	
I <sub>IX</sub>	Input leakage current	GND ≤ V <sub>IN</sub> ≤ V <sub>CC</sub>	-1	-	+1	μA	
I <sub>OZ</sub>	Output leakage current	GND ≤ V <sub>OUT</sub> ≤ V <sub>CC</sub> , Output disabled	-1	-	+1	μA	
I <sub>CC</sub>	Operating supply current	Max V <sub>CC</sub> , I <sub>OUT</sub> = 0 mA, CMOS levels	f = 100 MHz	-	38	45	mA
			f = 66.7 MHz	-	-	40	
I <sub>SB1</sub>	Automatic CE power-down current – TTL inputs	Max V <sub>CC</sub> , CE ≥ V <sub>IH</sub> , V <sub>IN</sub> ≥ V <sub>IH</sub> or V <sub>IN</sub> ≤ V <sub>IL</sub> , f = f <sub>MAX</sub>	-	-	15	mA	
I <sub>SB2</sub>	Automatic CE power-down current – CMOS inputs	Max V <sub>CC</sub> , CE ≥ V <sub>CC</sub> - 0.2 V, V <sub>IN</sub> ≥ V <sub>CC</sub> - 0.2 V or V <sub>IN</sub> ≤ 0.2 V, f = 0	-	6	8	mA	

### Notes

9. V<sub>IL(min)</sub> = -2.0 V and V<sub>IH(max)</sub> = V<sub>CC</sub> + 2 V for pulse durations of less than 2 ns.

10. Typical values are included for reference only and are not guaranteed or tested. Typical values are measured at V<sub>CC</sub> = 1.8 V (for V<sub>CC</sub> range of 1.65 V – 2.2 V), V<sub>CC</sub> = 3 V (for V<sub>CC</sub> range of 2.2 V – 3.6 V), and V<sub>CC</sub> = 5 V (for V<sub>CC</sub> range of 4.5 V – 5.5 V), T<sub>A</sub> = 25 °C.

11. This parameter is guaranteed by design and not tested.

## Capacitance

Parameter <sup>[12]</sup>	Description	Test Conditions	48-ball VFBGA	44-pin SOJ	44-pin TSOP II	Unit
C <sub>IN</sub>	Input capacitance	T <sub>A</sub> = 25 °C, f = 1 MHz, V <sub>CC</sub> = V <sub>CC(typ)</sub>	10	10	10	pF
C <sub>OUT</sub>	I/O capacitance		10	10	10	pF

## Thermal Resistance

Parameter <sup>[12]</sup>	Description	Test Conditions	48-ball VFBGA	44-pin SOJ	44-pin TSOP II	Unit
Θ <sub>JA</sub>	Thermal resistance (junction to ambient)	Still air, soldered on a 3 × 4.5 inch, four layer printed circuit board	31.35	55.37	68.85	°C/W
Θ <sub>JC</sub>	Thermal resistance (junction to case)		14.74	30.41	15.97	°C/W

## AC Test Loads and Waveforms

Figure 7. AC Test Loads and Waveforms <sup>[13]</sup>

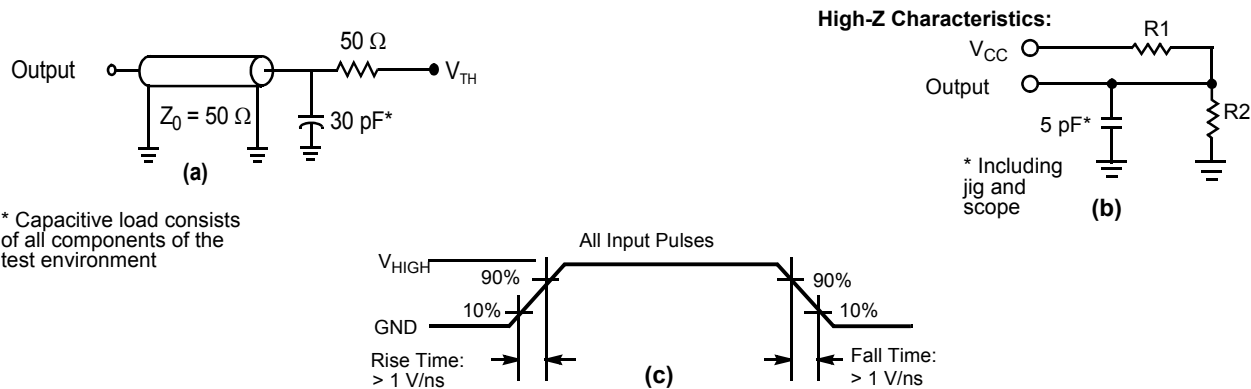

\* Capacitive load consists of all components of the test environment

Parameters	1.8 V	3.0 V	5.0 V	Unit
R1	1667	317	317	Ω
R2	1538	351	351	Ω
V <sub>TH</sub>	0.9	1.5	1.5	V
V <sub>HIGH</sub>	1.8	3	3	V

### Notes

12. Tested initially and after any design or process changes that may affect these parameters.

13. Full-device AC operation assumes a 100-μs ramp time from 0 to V<sub>CC(min)</sub> and a 100-μs wait time after V<sub>CC</sub> stabilization.

## Data Retention Characteristics

Over the operating range of  $-40\text{ }^{\circ}\text{C}$  to  $85\text{ }^{\circ}\text{C}$

Parameter	Description	Conditions	Min	Max	Unit
$V_{DR}$	$V_{CC}$ for data retention		1	–	V
$I_{CCDR}$	Data retention current	$V_{CC} = 1.2\text{ V}$ , $\overline{CE} \geq V_{CC} - 0.2\text{ V}$ <sup>[14]</sup> , $V_{IN} \geq V_{CC} - 0.2\text{ V}$ , or $V_{IN} \leq 0.2\text{ V}$	–	8	mA
$t_{CDR}$ <sup>[15]</sup>	Chip deselect to data retention time		0	–	ns
$t_R$ <sup>[14, 15]</sup>	Operation recovery time	$V_{CC} \geq 2.2\text{ V}$	10	–	ns
		$V_{CC} < 2.2\text{ V}$	15	–	ns

## Data Retention Waveform

Figure 8. Data Retention Waveform<sup>[14]</sup>

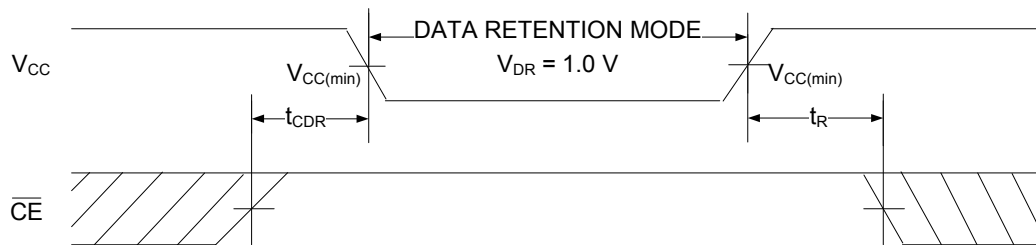

### Notes

14. Full-device operation requires linear  $V_{CC}$  ramp from  $V_{DR}$  to  $V_{CC(min)}$   $\geq 100\text{ }\mu\text{s}$  or stable at  $V_{CC(min)}$   $\geq 100\text{ }\mu\text{s}$ .
15. These parameters are guaranteed by design.



## AC Switching Characteristics

Over the operating range of –40 °C to 85 °C

Parameter <sup>[16]</sup>	Description	10 ns		15 ns		Unit
		Min	Max	Min	Max	
<b>Read Cycle</b>						
t <sub>RC</sub>	Read cycle time	10	–	15	–	ns
t <sub>AA</sub>	Address to data / ERR valid	–	10	–	15	ns
t <sub>OHA</sub>	Data / ERR hold from address change	3	–	3	–	ns
t <sub>ACE</sub>	$\overline{CE}$ LOW to data / ERR valid <sup>[17]</sup>	–	10	–	15	ns
t <sub>DOE</sub>	$\overline{OE}$ LOW to data / ERR valid	–	4.5	–	8	ns
t <sub>LZOE</sub>	$\overline{OE}$ LOW to low impedance <sup>[18, 19]</sup>	0	–	0	–	ns
t <sub>HZOE</sub>	$\overline{OE}$ HIGH to HI-Z <sup>[18, 19]</sup>	–	5	–	8	ns
t <sub>LZCE</sub>	$\overline{CE}$ LOW to low impedance <sup>[17, 18, 19]</sup>	3	–	3	–	ns
t <sub>HZCE</sub>	$\overline{CE}$ HIGH to HI-Z <sup>[17, 18, 19]</sup>	–	5	–	8	ns
t <sub>PU</sub>	$\overline{CE}$ LOW to power-up <sup>[17, 19, 20]</sup>	0	–	0	–	ns
t <sub>PD</sub>	$\overline{CE}$ HIGH to power-down <sup>[17, 19, 20]</sup>	–	10	–	15	ns
t <sub>DBE</sub>	Byte enable to data valid	–	4.5	–	8	ns
t <sub>LZBE</sub>	Byte enable to low impedance <sup>[19]</sup>	0	–	0	–	ns
t <sub>HZBE</sub>	Byte disable to HI-Z <sup>[19]</sup>	–	6	–	8	ns
<b>Write Cycle <sup>[20, 21]</sup></b>						
t <sub>WC</sub>	Write cycle time	10	–	15	–	ns
t <sub>SCE</sub>	$\overline{CE}$ LOW to write end <sup>[17]</sup>	7	–	12	–	ns
t <sub>AW</sub>	Address setup to write end	7	–	12	–	ns
t <sub>HA</sub>	Address hold from write end	0	–	0	–	ns
t <sub>SA</sub>	Address setup to write start	0	–	0	–	ns
t <sub>PWE</sub>	$\overline{WE}$ pulse width	7	–	12	–	ns
t <sub>SD</sub>	Data setup to write end	5	–	8	–	ns
t <sub>HD</sub>	Data hold from write end	0	–	0	–	ns
t <sub>LZWE</sub>	$\overline{WE}$ HIGH to low impedance <sup>[18, 19]</sup>	3	–	3	–	ns
t <sub>HZWE</sub>	$\overline{WE}$ LOW to HI-Z <sup>[18, 19]</sup>	–	5	–	8	ns
t <sub>BW</sub>	Byte Enable to write end	7	–	12	–	ns

### Notes

- Test conditions assume a signal transition time (rise/fall) of 3 ns or less, timing reference levels of 1.5 V (for  $V_{CC} \geq 3$  V) and  $V_{CC}/2$  (for  $V_{CC} < 3$  V), and input pulse levels of 0 to 3 V (for  $V_{CC} \geq 3$  V) and 0 to  $V_{CC}$  (for  $V_{CC} < 3$  V). Test conditions for the read cycle use output loading, as shown in part (a) of Figure 7 on page 7, unless specified otherwise.
- For all dual chip enable devices,  $\overline{CE}$  is the logical combination of  $\overline{CE}_1$  and  $CE_2$ . When  $\overline{CE}_1$  is LOW and  $CE_2$  is HIGH,  $\overline{CE}$  is LOW; when  $\overline{CE}_1$  is HIGH or  $CE_2$  is LOW,  $\overline{CE}$  is HIGH.
- t<sub>HZOE</sub>, t<sub>HZCE</sub>, t<sub>HZWE</sub>, t<sub>HZBE</sub>, t<sub>LZOE</sub>, t<sub>LZCE</sub>, t<sub>LZWE</sub>, and t<sub>LZBE</sub> are specified with a load capacitance of 5 pF, as shown in part (b) of Figure 7 on page 7. Transition is measured ±200 mV from steady state voltage.
- These parameters are guaranteed by design and are not tested.
- The internal write time of the memory is defined by the overlap of  $\overline{WE} = V_{IL}$ ,  $\overline{CE} = V_{IL}$ , and  $\overline{BHE}$  or  $\overline{BLE} = V_{IL}$ . These signals must be LOW to initiate a write, and the HIGH transition of any of these signals can terminate the operation. The input data setup and hold timing should be referenced to the edge of the signal that terminates the write.
- The minimum write cycle pulse width in Write Cycle No 2 ( $\overline{WE}$  Controlled,  $\overline{OE}$  LOW) should be equal to sum of t<sub>sd</sub> and t<sub>HZWE</sub>.

## Switching Waveforms

**Figure 9. Read Cycle No. 1 of CY7C1041G (Address Transition Controlled)** [22, 23]

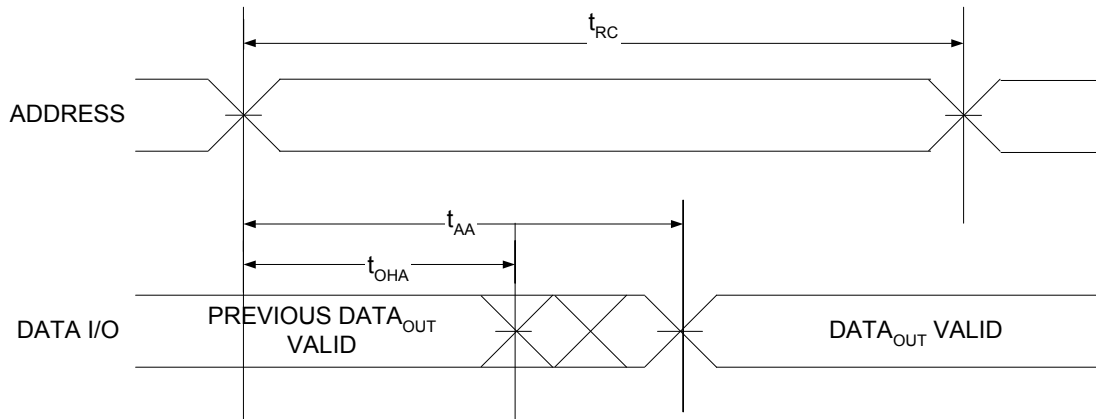

**Figure 10. Read Cycle No. 1 of CY7C1041GE (Address Transition Controlled)** [22, 23]

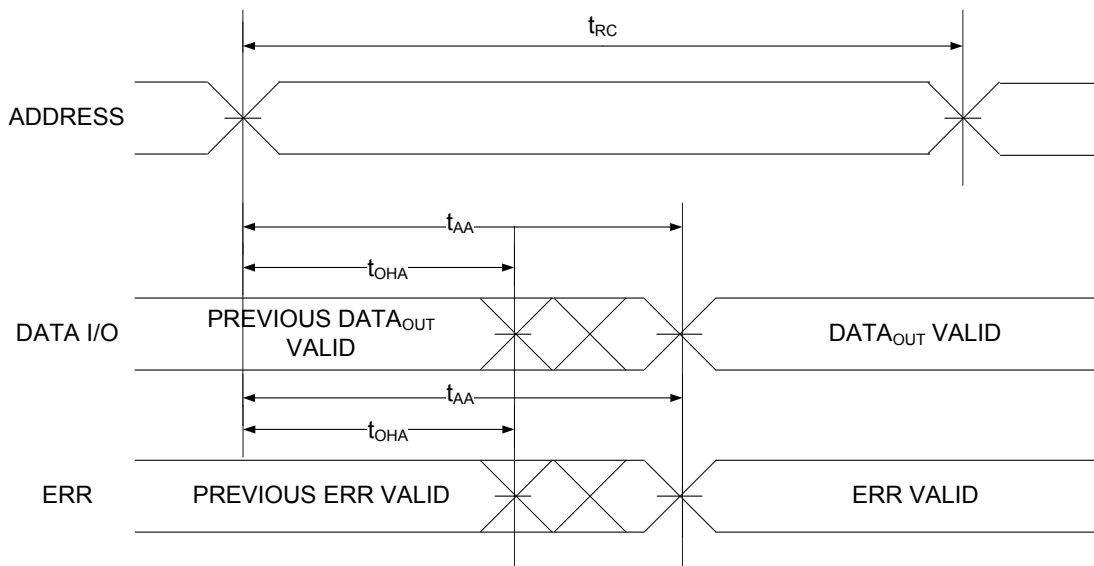

### Notes

22. The device is continuously selected,  $\overline{OE} = V_{IL}$ ,  $\overline{CE} = V_{IL}$ ,  $\overline{BHE}$  or  $\overline{BLE}$  or both =  $V_{IL}$ .  
23.  $\overline{WE}$  is HIGH for the read cycle.

**Switching Waveforms** (continued)

**Figure 11. Read Cycle No. 2 ( $\overline{\text{OE}}$  Controlled)** [24, 25, 26]

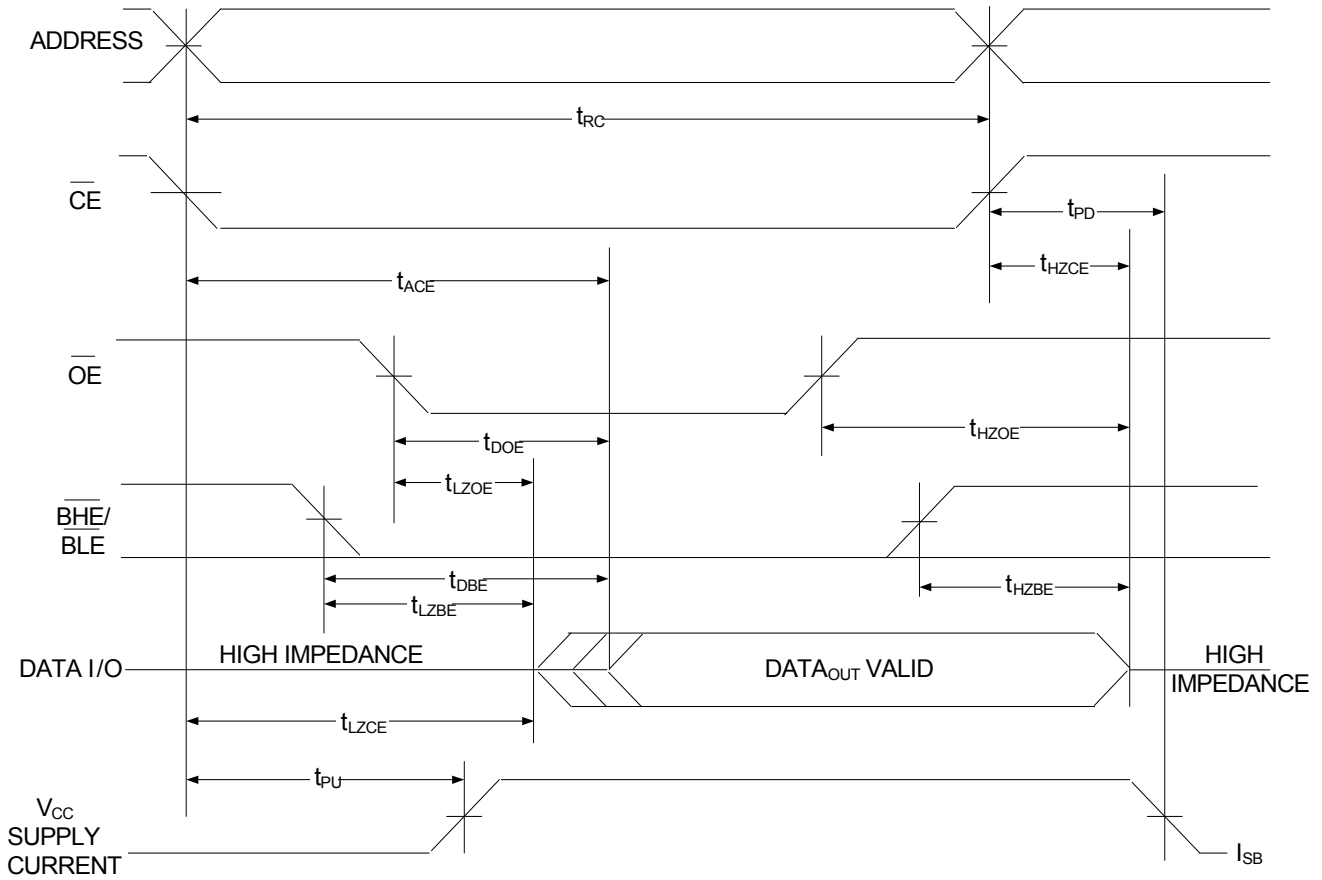

**Notes**

- 24. For all dual chip enable devices,  $\overline{\text{CE}}$  is the logical combination of  $\overline{\text{CE}}_1$  and  $\text{CE}_2$ . When  $\overline{\text{CE}}_1$  is LOW and  $\text{CE}_2$  is HIGH,  $\overline{\text{CE}}$  is LOW; when  $\overline{\text{CE}}_1$  is HIGH or  $\text{CE}_2$  is LOW,  $\overline{\text{CE}}$  is HIGH.
- 25.  $\overline{\text{WE}}$  is HIGH for the read cycle.
- 26. Address valid prior to or coincident with  $\overline{\text{CE}}$  LOW transition.

**Switching Waveforms** (continued)

**Figure 12. Write Cycle No. 1 ( $\overline{CE}$  Controlled)** [27, 28, 29]

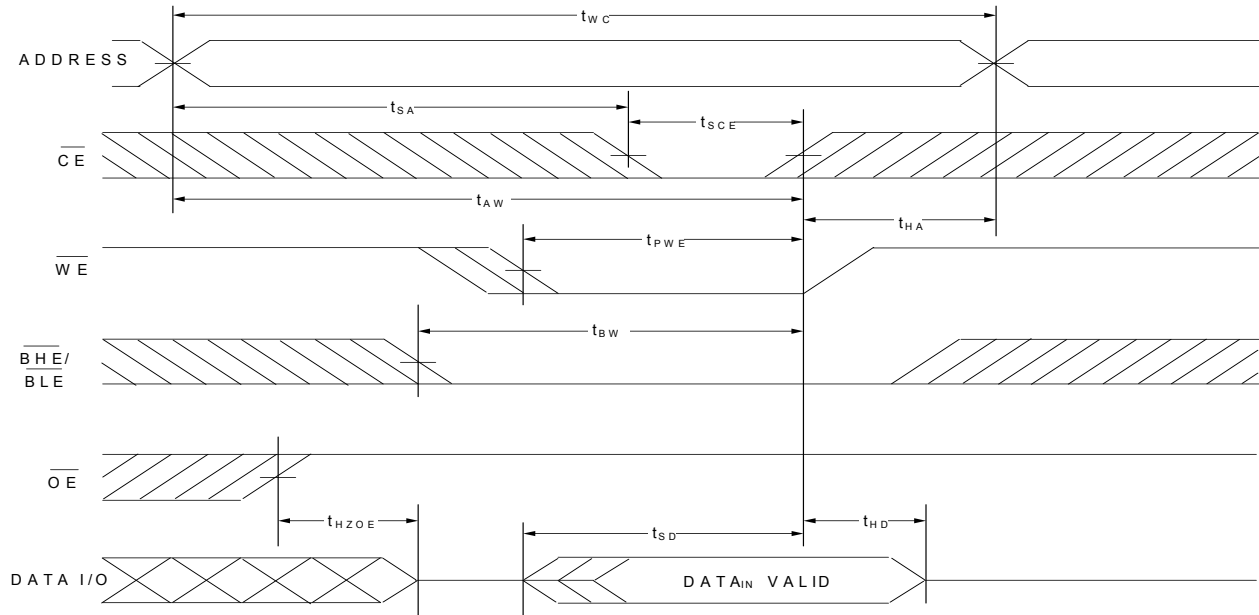

**Figure 13. Write Cycle No. 2 ( $\overline{WE}$  Controlled,  $\overline{OE}$  LOW)** [27, 28, 29, 30]

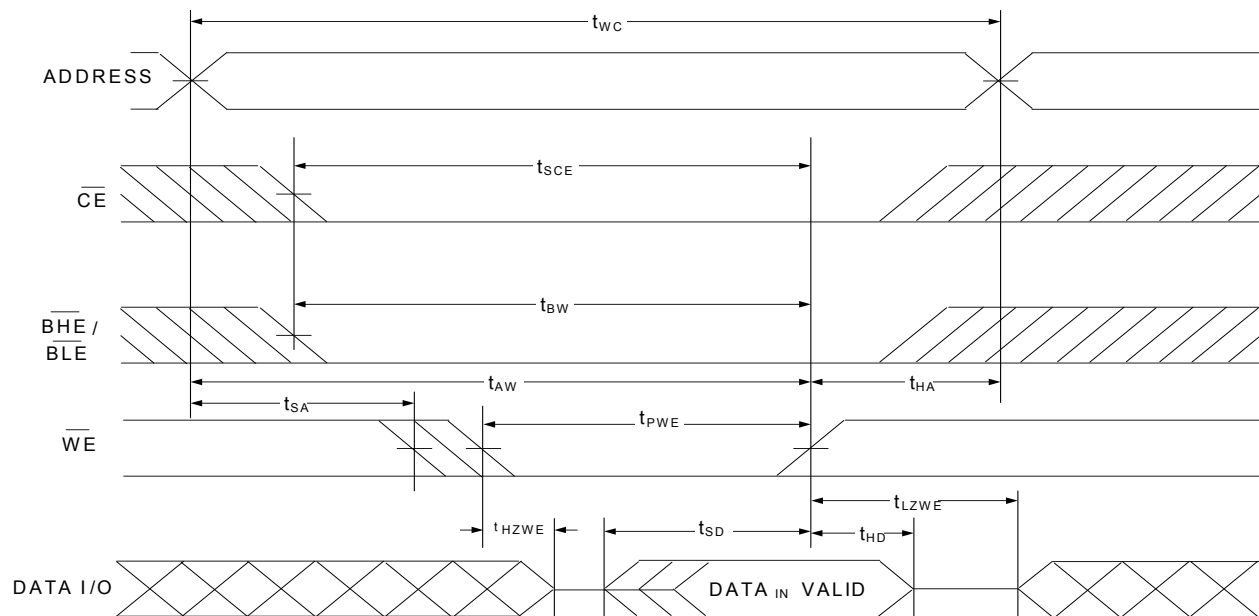

**Notes**

27. For all dual chip enable devices,  $\overline{CE}$  is the logical combination of  $\overline{CE}_1$  and  $CE_2$ . When  $\overline{CE}_1$  is LOW and  $CE_2$  is HIGH,  $\overline{CE}$  is LOW; when  $\overline{CE}_1$  is HIGH or  $CE_2$  is LOW,  $\overline{CE}$  is HIGH.
28. The internal write time of the memory is defined by the overlap of  $\overline{WE} = V_{IL}$ ,  $\overline{CE} = V_{IL}$ , and  $\overline{BHE}$  or  $\overline{BLE} = V_{IL}$ . These signals must be LOW to initiate a write, and the HIGH transition of any of these signals can terminate the operation. The input data setup and hold timing should be referenced to the edge of the signal that terminates the write.
29. Data I/O is in HI-Z state if  $\overline{CE} = V_{IH}$ , or  $\overline{OE} = V_{IH}$ , or  $\overline{BHE}$ , and/or  $\overline{BLE} = V_{IH}$ .
30. The minimum write cycle pulse width should be equal to sum of  $t_{SD}$  and  $t_{HZWE}$ .

**Switching Waveforms** (continued)

**Figure 14. Write Cycle No. 3 ( $\overline{\text{BLE}}$  or  $\overline{\text{BHE}}$  Controlled)** [31, 32, 33]

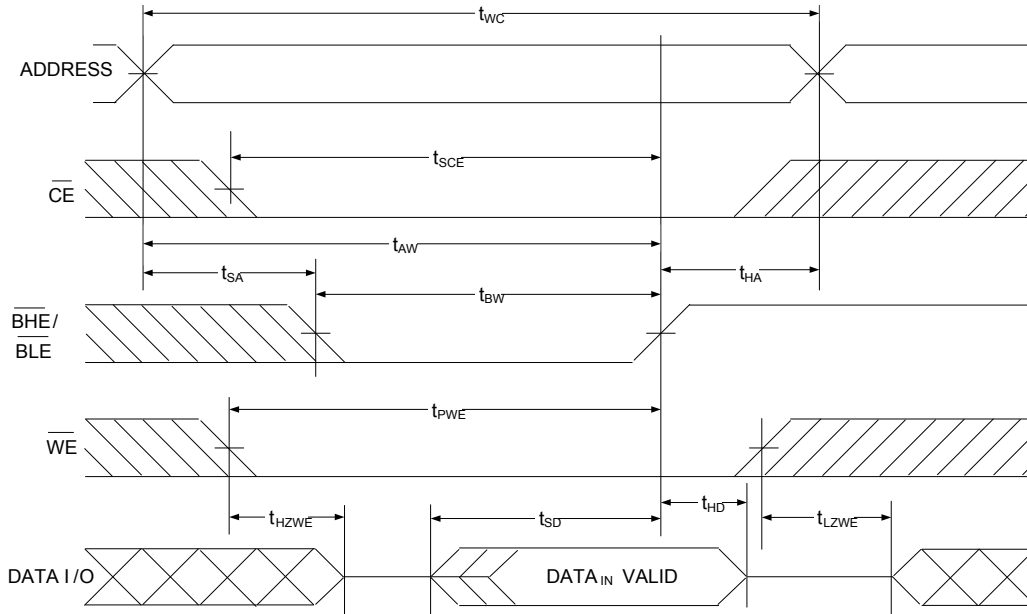

**Figure 15. Write Cycle No. 4 ( $\overline{\text{WE}}$  Controlled)** [31, 32, 33, 34]

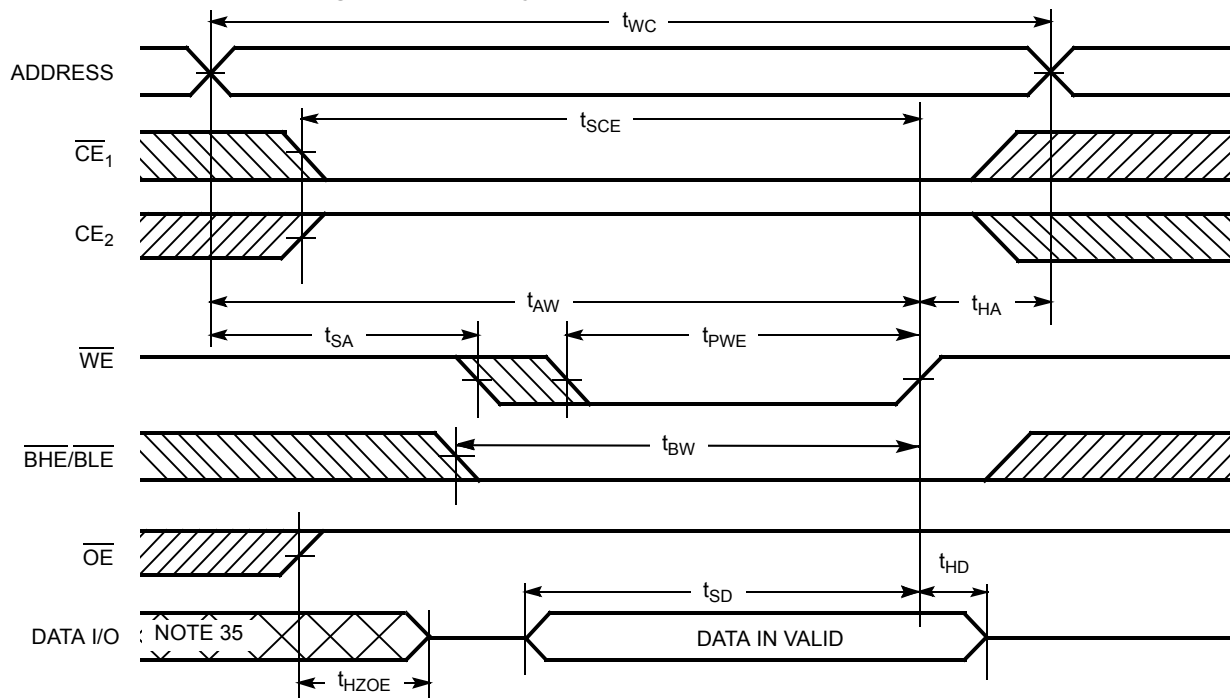

**Notes**

- 31. For all dual chip enable devices,  $\overline{\text{CE}}$  is the logical combination of  $\overline{\text{CE}}_1$  and  $\text{CE}_2$ . When  $\overline{\text{CE}}_1$  is LOW and  $\text{CE}_2$  is HIGH,  $\overline{\text{CE}}$  is LOW; when  $\overline{\text{CE}}_1$  is HIGH or  $\text{CE}_2$  is LOW,  $\overline{\text{CE}}$  is HIGH.
- 32. The internal write time of the memory is defined by the overlap of  $\overline{\text{WE}} = V_{\text{IL}}$ ,  $\overline{\text{CE}} = V_{\text{IL}}$ , and  $\overline{\text{BHE}}$  or  $\overline{\text{BLE}} = V_{\text{IL}}$ . These signals must be LOW to initiate a write, and the HIGH transition of any of these signals can terminate the operation. The input data setup and hold timing should be referenced to the edge of the signal that terminates the write.
- 33. Data I/O is in HI-Z state if  $\overline{\text{CE}} = V_{\text{IH}}$ , or  $\overline{\text{OE}} = V_{\text{IH}}$ , or  $\overline{\text{BHE}}$ , and/or  $\overline{\text{BLE}} = V_{\text{IH}}$ .
- 34. Data I/O is high impedance if  $\overline{\text{OE}} = V_{\text{IH}}$ .
- 35. During this period the I/Os are in output state. Do not apply input signals.

**Truth Table**

$\overline{CE}$ [36]	$\overline{OE}$	$\overline{WE}$	$\overline{BLE}$	$\overline{BHE}$	I/O <sub>0</sub> –I/O <sub>7</sub>	I/O <sub>8</sub> –I/O <sub>15</sub>	Mode	Power
H	X <sup>[37]</sup>	X <sup>[37]</sup>	X <sup>[37]</sup>	X <sup>[37]</sup>	HI-Z	HI-Z	Power down	Standby (I <sub>SB</sub> )
L	L	H	L	L	Data out	Data out	Read all bits	Active (I <sub>CC</sub> )
L	L	H	L	H	Data out	HI-Z	Read lower bits only	Active (I <sub>CC</sub> )
L	L	H	H	L	HI-Z	Data out	Read upper bits only	Active (I <sub>CC</sub> )
L	X	L	L	L	Data in	Data in	Write all bits	Active (I <sub>CC</sub> )
L	X	L	L	H	Data in	HI-Z	Write lower bits only	Active (I <sub>CC</sub> )
L	X	L	H	L	HI-Z	Data in	Write upper bits only	Active (I <sub>CC</sub> )
L	H	H	X	X	HI-Z	HI-Z	Selected, outputs disabled	Active (I <sub>CC</sub> )
L	X	X	H	H	HI-Z	HI-Z	Selected, outputs disabled	Active (I <sub>CC</sub> )

**ERR Output – CY7C1041GE**

Output [38]	Mode
0	Read operation, no single-bit error in the stored data.
1	Read operation, single-bit error detected and corrected.
HI-Z	Device deselected or outputs disabled or Write operation

**Notes**

36. For all dual chip enable devices,  $\overline{CE}$  is the logical combination of  $\overline{CE}_1$  and  $CE_2$ . When  $\overline{CE}_1$  is LOW and  $CE_2$  is HIGH,  $\overline{CE}$  is LOW; when  $\overline{CE}_1$  is HIGH or  $CE_2$  is LOW,  $\overline{CE}$  is HIGH.

37. The input voltage levels on these pins should be either at  $V_{IH}$  or  $V_{IL}$ .

38. ERR is an Output pin. If not used, this pin should be left floating

## Ordering Information

Speed (ns)	Voltage Range	Ordering Code	Package Diagram	Package Type (all Pb-free)	Operating Range
10	2.2 V–3.6 V	CY7C1041GE30-10ZSXI	51-85087	44-pin TSOP II, ERR output	Industrial
		CY7C1041G30-10ZSXI	51-85087	44-pin TSOP II	
		CY7C1041GE30-10BVXI	51-85150	48-ball VFBGA (6 × 8 × 1.0 mm), ERR output	
		CY7C1041G30-10BVXI	51-85150	48-ball VFBGA (6 × 8 × 1.0 mm)	
		CY7C1041G30-10BVJXI	51-85150	48-ball VFBGA (6 × 8 × 1.0 mm), JEDEC	
		CY7C1041G30-10VXI	51-85082	44-pin SOJ (400 Mils)	
		CY7C1041GE30-10VXI	51-85082	44-pin SOJ (400 Mils), ERR output	
	4.5 V–5.5 V	CY7C1041G-10ZSXI	51-85087	44-pin TSOP II	
		CY7C1041GE-10ZSXI	51-85087	44-pin TSOP II, ERR output	
		CY7C1041G-10VXI	51-85082	44-pin SOJ (400 Mils)	
15	1.65 V–2.2 V	CY7C1041G18-15ZSXI	51-85087	44-pin TSOP II	
		CY7C1041G18-15VXI	51-85082	44-pin SOJ (400 Mils)	
		CY7C1041G18-15BVXI	51-85150	48-ball VFBGA (6 × 8 × 1.0 mm)	

## Ordering Code Definitions

CY 7 C 1 04 1 G E XX - XX XXX I

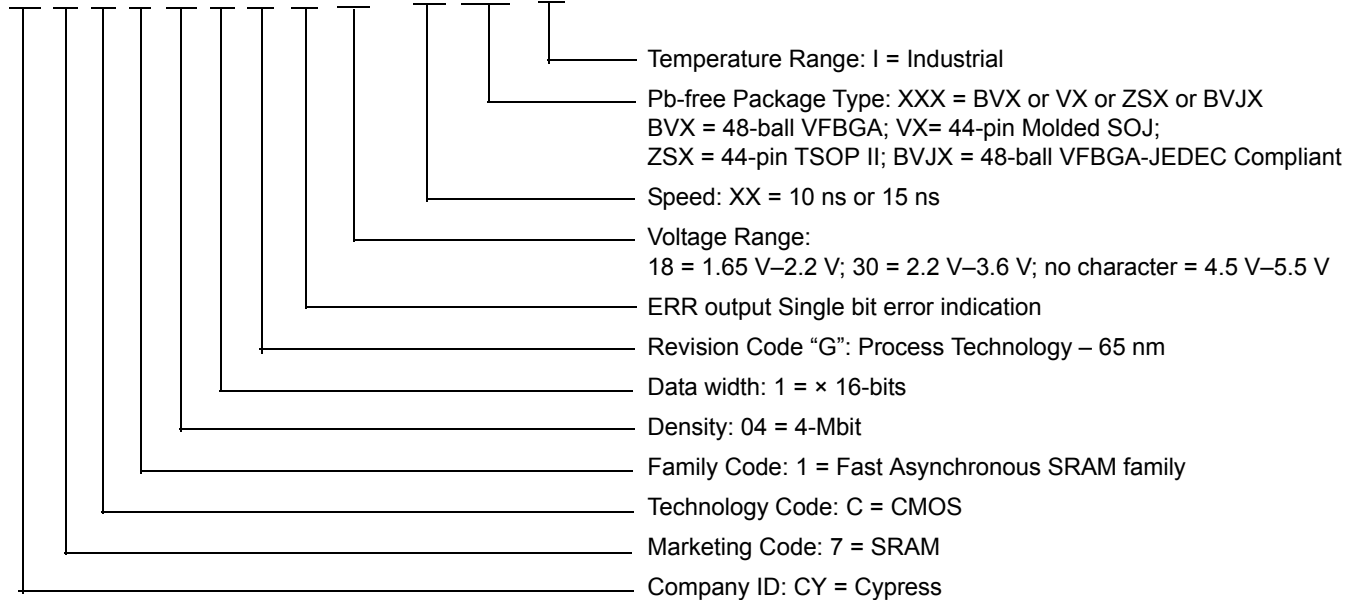

**Package Diagrams**

**Figure 16. 44-pin TSOP II (Z44) Package Outline, 51-85087**

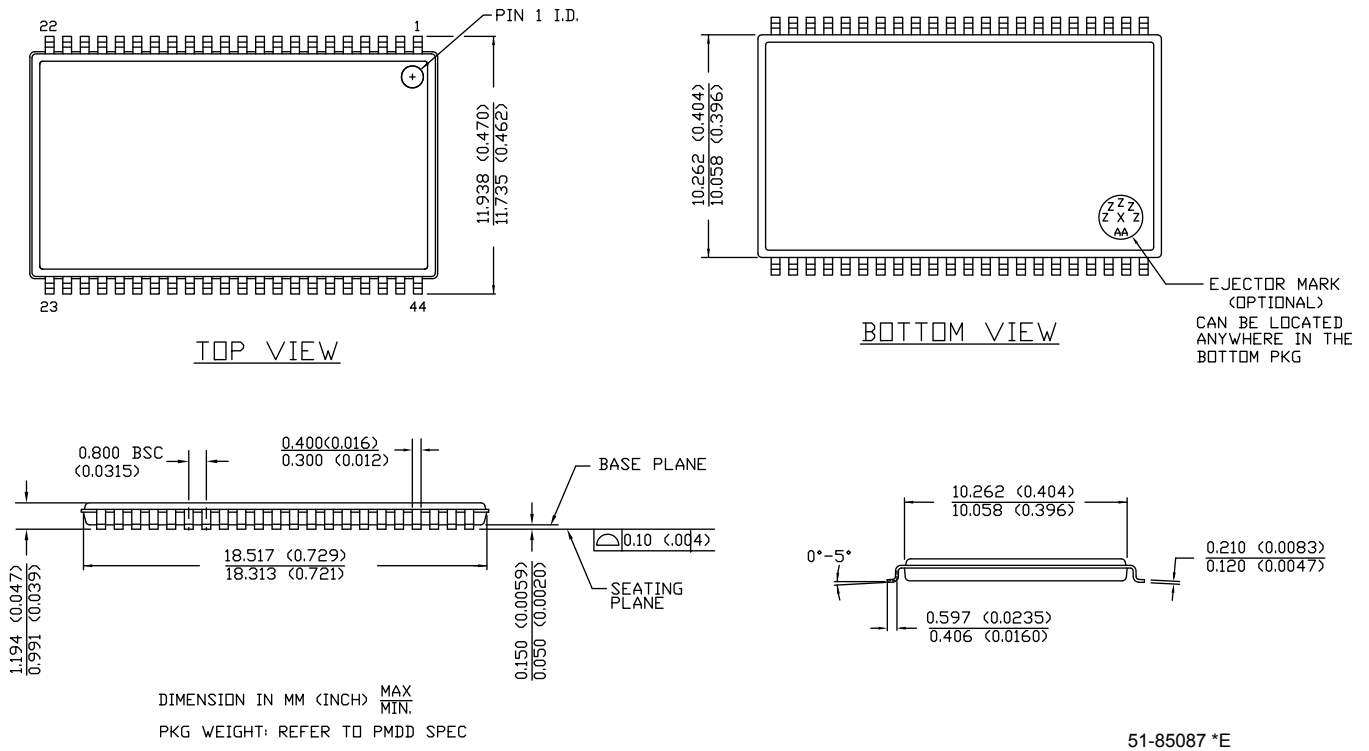

**Figure 17. 44-pin SOJ (400 Mils) Package Outline, 51-85082**

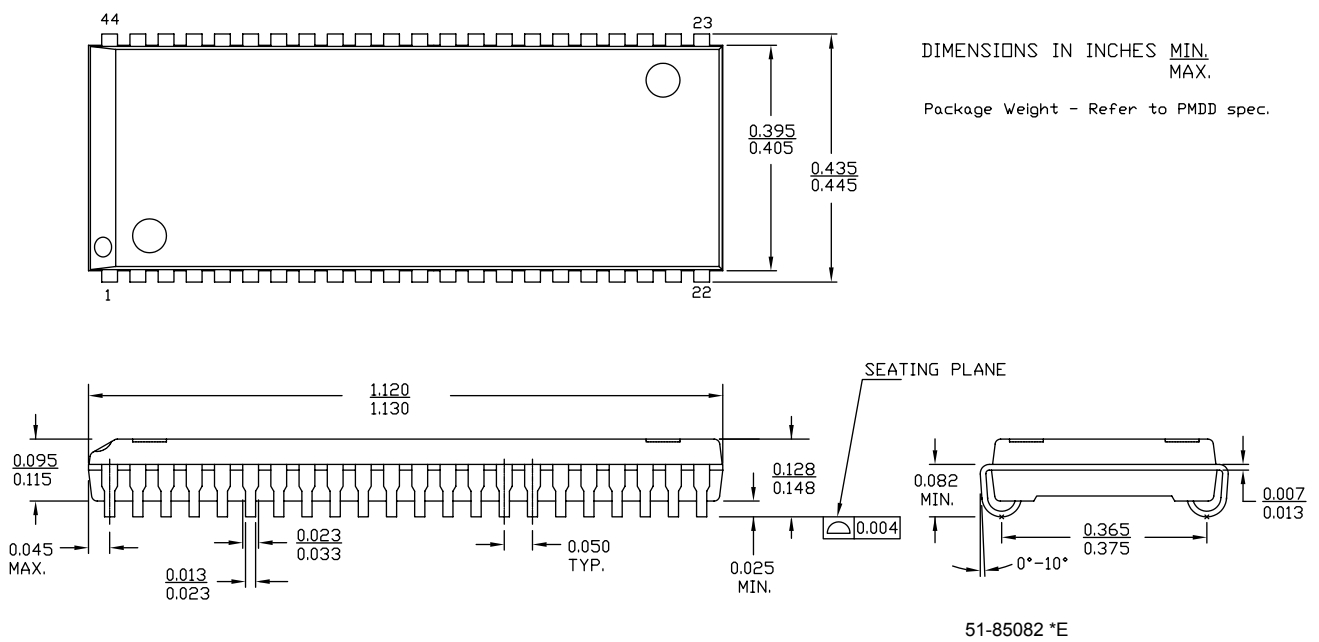



**Package Diagrams** (continued)

**Figure 18. 48-ball VFBGA (6 × 8 × 1.0 mm) BV48/BZ48 Package Outline, 51-85150**

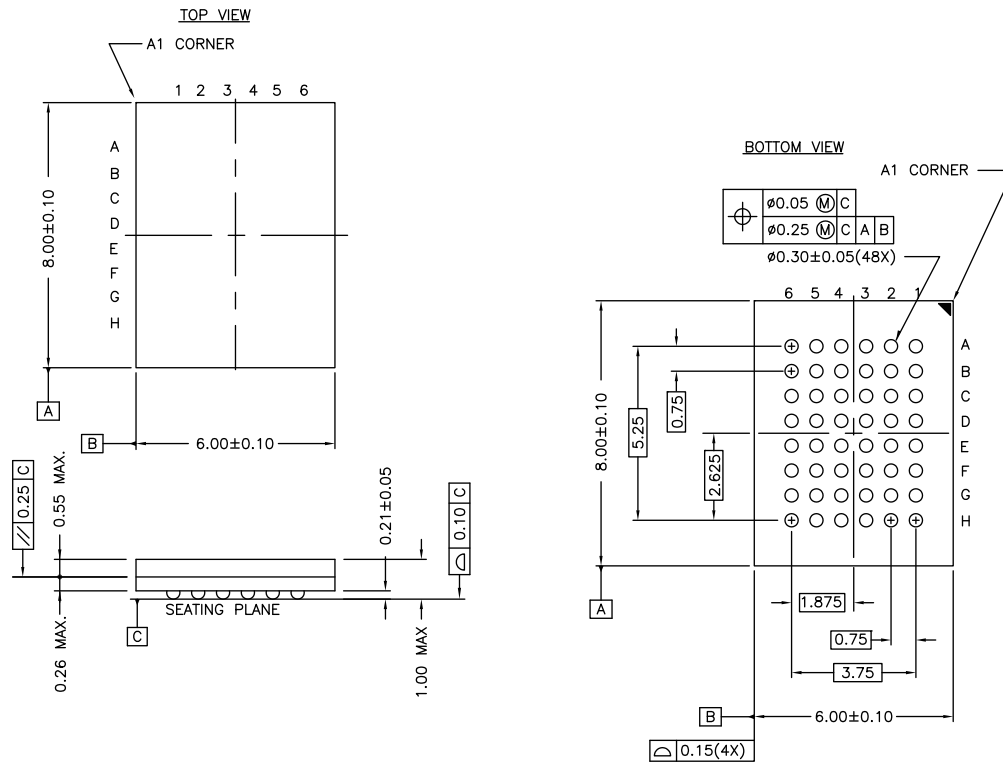

NOTE:  
PACKAGE WEIGHT: See Cypress Package Material Declaration Datasheet (PMDD) posted on the Cypress web.

51-85150 \*H

## Acronyms

Acronym	Description
$\overline{\text{BHE}}$	byte high enable
$\overline{\text{BLE}}$	byte low enable
$\overline{\text{CE}}$	chip enable
CMOS	complementary metal oxide semiconductor
I/O	input/output
$\overline{\text{OE}}$	output enable
SRAM	static random access memory
TSOP	thin small outline package
TTL	transistor-transistor logic
VFBGA	very fine-pitch ball grid array
$\overline{\text{WE}}$	write enable

## Document Conventions

### Units of Measure

Symbol	Unit of Measure
°C	Degrees Celsius
MHz	megahertz
μA	microamperes
μs	microseconds
mA	milliamperes
mm	millimeters
ns	nanoseconds
Ω	ohms
%	percent
pF	picofarads
V	volts
W	watts

## Document History Page

Document Title: CY7C1041G/CY7C1041GE, 4-Mbit (256K words × 16 bit) Static RAM with Error-Correcting Code (ECC) Document Number: 001-91368				
Rev.	ECN No.	Orig. of Change	Submission Date	Description of Change
*F	4867081	NILE	07/31/2015	Changed status from Preliminary to Final.
*G	4876251	NILE	08/07/2015	Updated <a href="#">Ordering Information</a> : Updated part numbers.
*H	4968879	NILE	10/16/2015	Fixed typo in bookmarks.
*I	5019226	VINI	11/18/2015	Updated <a href="#">Ordering Information</a> : Updated part numbers.
*J	5122043	NILE	02/02/2016	Updated <a href="#">Truth Table</a> .

## Sales, Solutions, and Legal Information

### Worldwide Sales and Design Support

Cypress maintains a worldwide network of offices, solution centers, manufacturer's representatives, and distributors. To find the office closest to you, visit us at [Cypress Locations](#).

#### Products

<a href="#">Automotive</a>	<a href="#">cypress.com/go/automotive</a>
<a href="#">Clocks &amp; Buffers</a>	<a href="#">cypress.com/go/clocks</a>
<a href="#">Interface</a>	<a href="#">cypress.com/go/interface</a>
<a href="#">Lighting &amp; Power Control</a>	<a href="#">cypress.com/go/powerpsoc</a>
<a href="#">Memory</a>	<a href="#">cypress.com/go/memory</a>
<a href="#">PSoC</a>	<a href="#">cypress.com/go/psoc</a>
<a href="#">Touch Sensing</a>	<a href="#">cypress.com/go/touch</a>
<a href="#">USB Controllers</a>	<a href="#">cypress.com/go/USB</a>
<a href="#">Wireless/RF</a>	<a href="#">cypress.com/go/wireless</a>

#### PSoC<sup>®</sup> Solutions

[psoc.cypress.com/solutions](#)  
[PSoC 1](#) | [PSoC 3](#) | [PSoC 4](#) | [PSoC 5LP](#)

#### Cypress Developer Community

[Community](#) | [Forums](#) | [Blogs](#) | [Video](#) | [Training](#)

#### Technical Support

[cypress.com/go/support](#)

---

© Cypress Semiconductor Corporation, 2014-2016. The information contained herein is subject to change without notice. Cypress Semiconductor Corporation assumes no responsibility for the use of any circuitry other than circuitry embodied in a Cypress product. Nor does it convey or imply any license under patent or other rights. Cypress products are not warranted nor intended to be used for medical, life support, life saving, critical control or safety applications, unless pursuant to an express written agreement with Cypress. Furthermore, Cypress does not authorize its products for use as critical components in life-support systems where a malfunction or failure may reasonably be expected to result in significant injury to the user. The inclusion of Cypress products in life-support systems application implies that the manufacturer assumes all risk of such use and in doing so indemnifies Cypress against all charges.

Any Source Code (software and/or firmware) is owned by Cypress Semiconductor Corporation (Cypress) and is protected by and subject to worldwide patent protection (United States and foreign), United States copyright laws and international treaty provisions. Cypress hereby grants to licensee a personal, non-exclusive, non-transferable license to copy, use, modify, create derivative works of, and compile the Cypress Source Code and derivative works for the sole purpose of creating custom software and or firmware in support of licensee product to be used only in conjunction with a Cypress integrated circuit as specified in the applicable agreement. Any reproduction, modification, translation, compilation, or representation of this Source Code except as specified above is prohibited without the express written permission of Cypress.

Disclaimer: CYPRESS MAKES NO WARRANTY OF ANY KIND, EXPRESS OR IMPLIED, WITH REGARD TO THIS MATERIAL, INCLUDING, BUT NOT LIMITED TO, THE IMPLIED WARRANTIES OF MERCHANTABILITY AND FITNESS FOR A PARTICULAR PURPOSE. Cypress reserves the right to make changes without further notice to the materials described herein. Cypress does not assume any liability arising out of the application or use of any product or circuit described herein. Cypress does not authorize its products for use as critical components in life-support systems where a malfunction or failure may reasonably be expected to result in significant injury to the user. The inclusion of Cypress' product in a life-support systems application implies that the manufacturer assumes all risk of such use and in doing so indemnifies Cypress against all charges.

Use may be limited by and subject to the applicable Cypress software license agreement.