

## Features

- True dual-ported memory cells which enable simultaneous access of the same memory location
- 4, 8 or 16K x 16 organization
- (CY7C024AV/024BV<sup>[1]</sup>/ 025AV/026AV)
- 4 or 8K x 18 organization (CY7C0241AV/0251AV)
- 16K x 18 organization (CY7C036AV)
- 0.35 micron CMOS for optimum speed and power
- High speed access: 20 and 25 ns
- Low operating power
  - Active:  $I_{CC} = 115 \text{ mA}$  (typical)
  - Standby:  $I_{SB3} = 10 \mu\text{A}$  (typical)
- Fully asynchronous operation
- Automatic power down
- Expandable data bus to 32 bits, 36 bits or more using Master and Slave chip select when using more than one device
- On chip arbitration logic
- Semaphores included to permit software handshaking between ports
- $\overline{\text{INT}}$  flag for port-to-port communication
- Separate upper byte and lower byte control
- Pin select for Master or Slave (M/S)
- Commercial and industrial temperature ranges
- Available in 100-pin Pb-free TQFP and 100-pin TQFP

## Logic Block Diagram

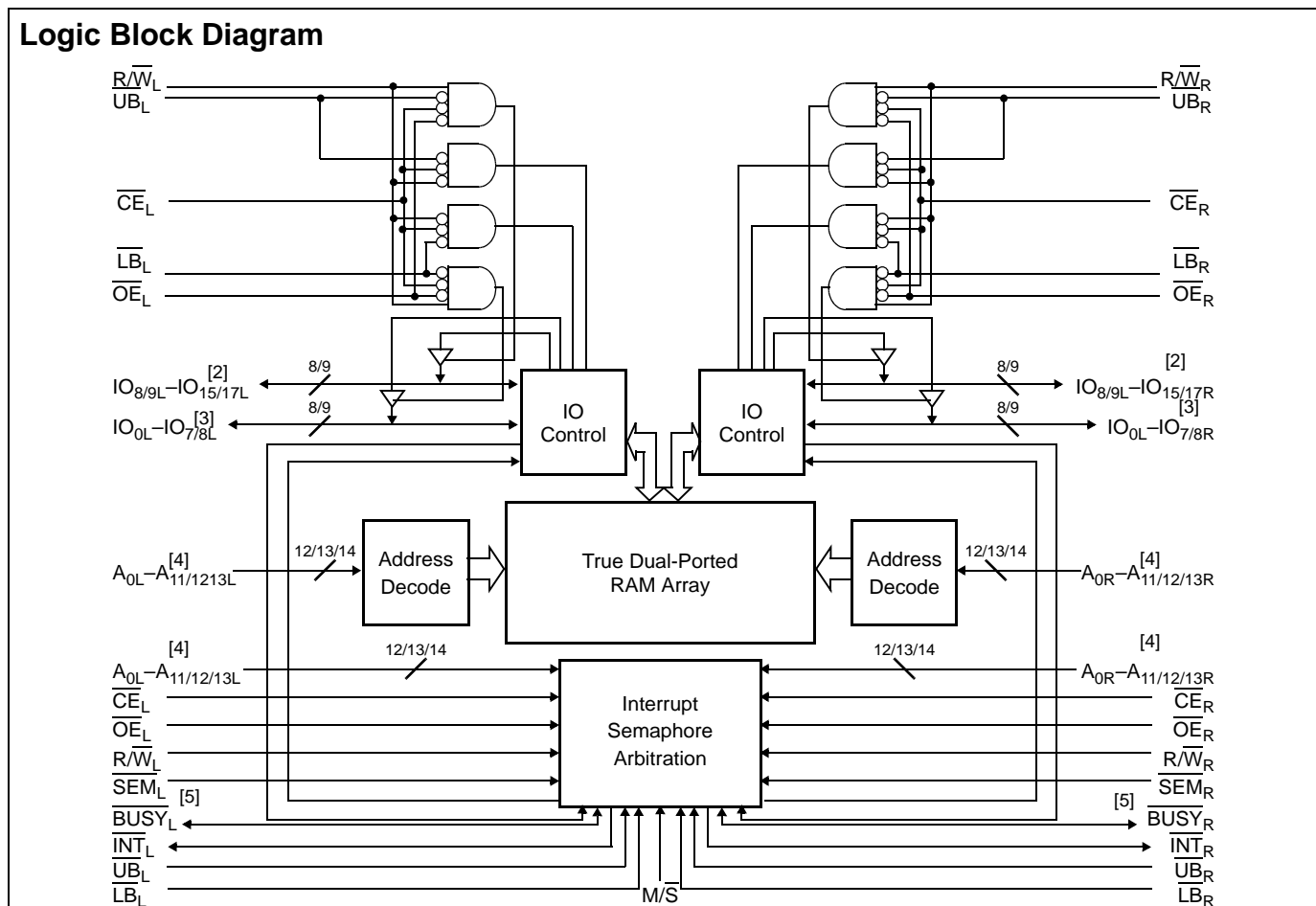

### Notes

1. CY7C024AV and CY7C024BV are functionally identical.
2.  $\text{IO}_8\text{--}\text{IO}_{15}$  for x16 devices;  $\text{IO}_9\text{--}\text{IO}_{17}$  for x18 devices.
3.  $\text{IO}_7\text{--}\text{IO}_7$  for x16 devices;  $\text{IO}_7\text{--}\text{IO}_8$  for x18 devices.
4.  $\text{A}_0\text{--}\text{A}_{11}$  for 4K devices;  $\text{A}_0\text{--}\text{A}_{12}$  for 8K devices;  $\text{A}_0\text{--}\text{A}_{13}$  for 16K devices.
5. BUSY is an output in master mode and an input in slave mode.

**Pin Configurations**

**Figure 1. 100-Pin TQFP (Top View)**

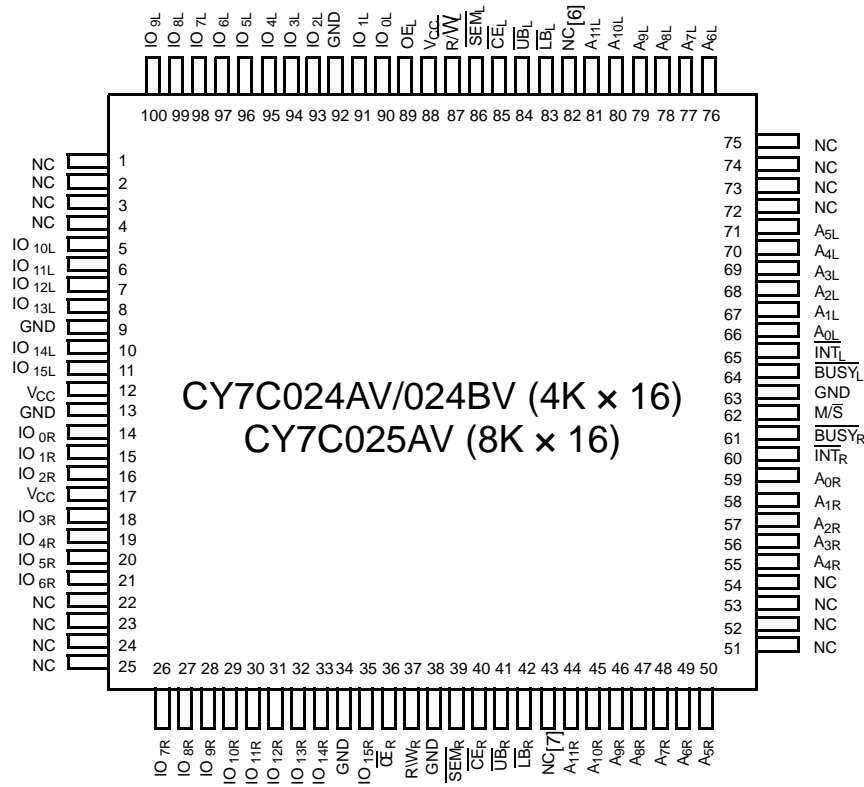

**Notes**

- 6. A<sub>12L</sub> on the CY7C025AV.
- 7. A<sub>12R</sub> on the CY7C025AV.

**Pin Configurations** (continued)

**Figure 2. 100-Pin TQFP (Top View)**

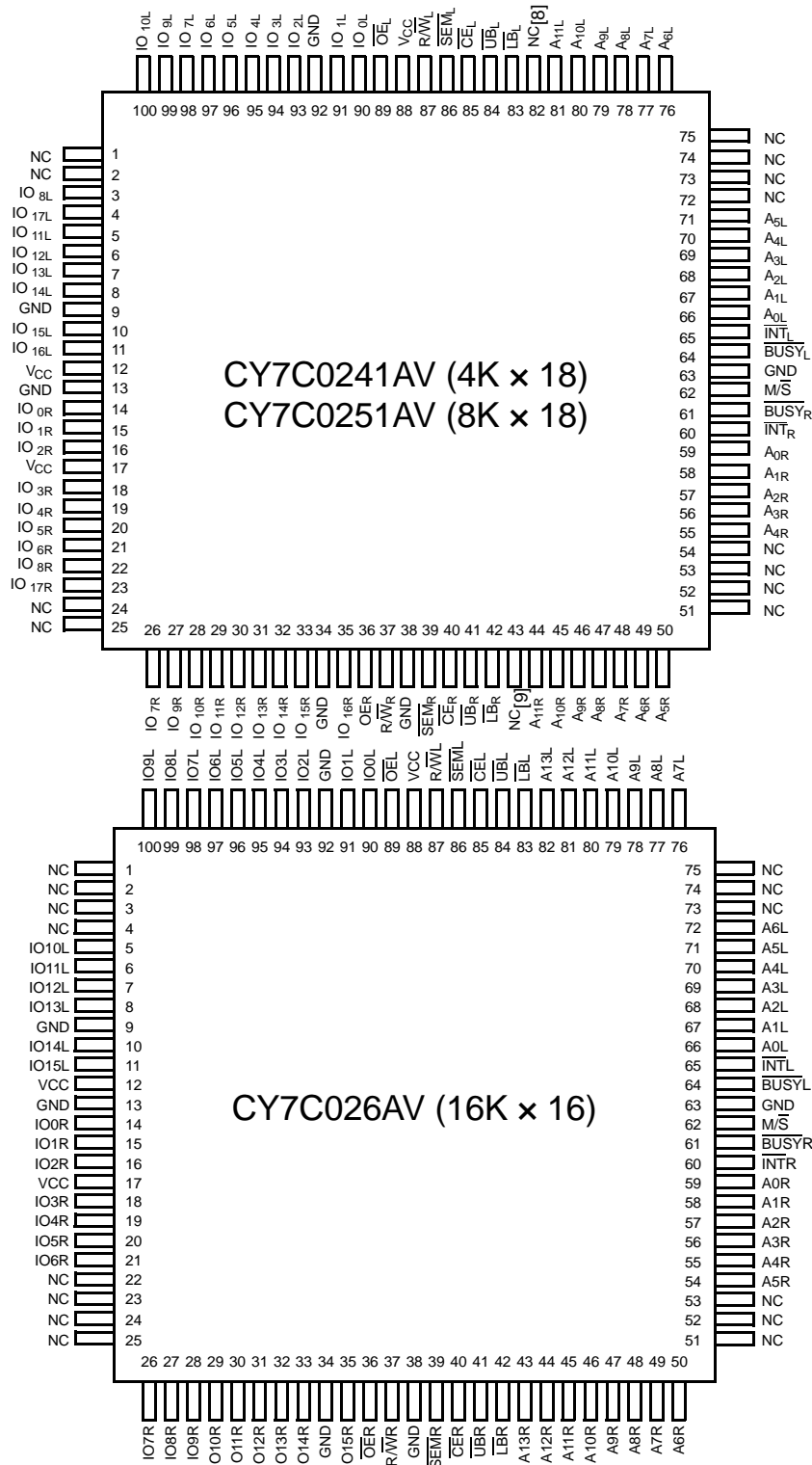

- Notes**
- 8. A<sub>12L</sub> on the CY7C0251AV.
  - 9. A<sub>12R</sub> on the CY7C0251AVC.

**Pin Configurations** (continued)

**Figure 3. 100-Pin TQFP (Top View)**

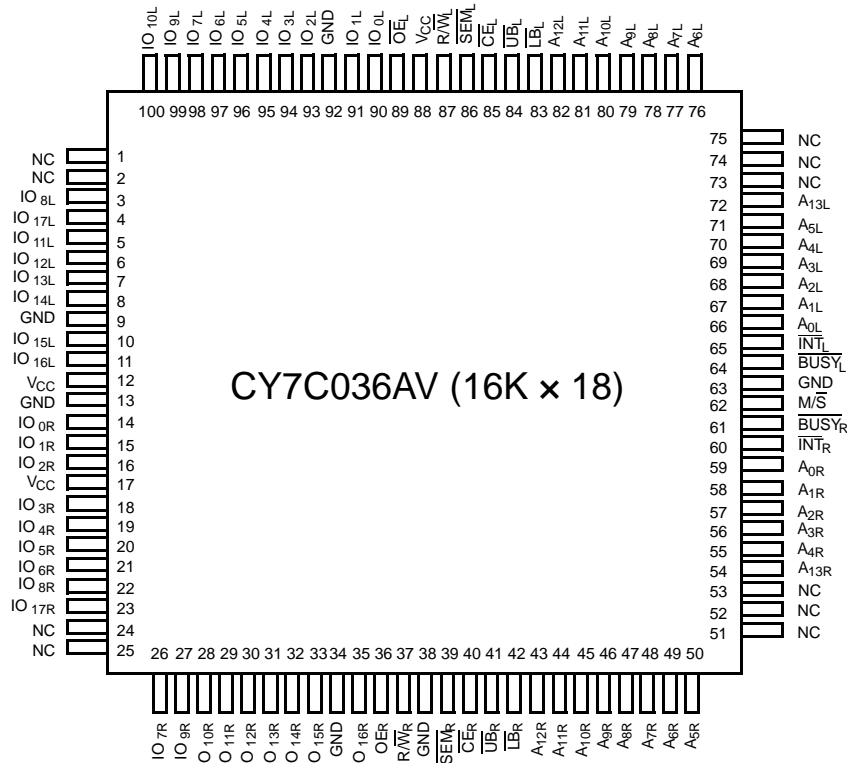

**Selection Guide**

Parameter	CY7C024AV/024BV/025AV/026AV CY7C0241AV/0251AV/036AV -20	CY7C024AV/024BV/025AV/026AV CY7C0241AV/0251AV/036AV -25	Unit
Maximum Access Time	20	25	ns
Typical Operating Current	120	115	mA
Typical Standby Current for I <sub>SB1</sub> (Both ports TTL Level)	35	30	mA
Typical Standby Current for I <sub>SB3</sub> (Both ports CMOS Level)	10	10	μA

## Pin Definitions

Left Port	Right Port	Description
$\overline{CE}_L$	$\overline{CE}_R$	Chip Enable
$R/\overline{W}_L$	$R/\overline{W}_R$	Read and Write Enable
$\overline{OE}_L$	$\overline{OE}_R$	Output Enable
$A_{0L}-A_{13L}$	$A_{0R}-A_{13R}$	Address ( $A_0-A_{11}$ for 4K devices; $A_0-A_{12}$ for 8K devices; $A_0-A_{13}$ for 16K)
$IO_{0L}-IO_{17L}$	$IO_{0R}-IO_{17R}$	Data Bus Input and Output
$\overline{SEM}_L$	$\overline{SEM}_R$	Semaphore Enable
$\overline{UB}_L$	$\overline{UB}_R$	Upper Byte Select ( $IO_8-IO_{15}$ for x16 devices; $IO_9-IO_{17}$ for x18 devices)
$\overline{LB}_L$	$\overline{LB}_R$	Lower Byte Select ( $IO_0-IO_7$ for x16 devices; $IO_0-IO_8$ for x18 devices)
$\overline{INT}_L$	$\overline{INT}_R$	Interrupt Flag
$\overline{BUSY}_L$	$\overline{BUSY}_R$	Busy Flag
$M/\overline{S}$		Master or Slave Select
$V_{CC}$		Power
GND		Ground
NC		No Connect

## Architecture

The CY7C024AV/024BV/025AV/026AV and CY7C0241AV/0251AV/036AV consist of an array of 4K, 8K, and 16K words of 16 and 18 bits each of dual-port RAM cells, IO and address lines, and control signals ( $\overline{CE}$ ,  $\overline{OE}$ ,  $R/W$ ). These control pins permit independent access for reads or writes to any location in memory. To handle simultaneous writes and reads to the same location, a  $\overline{BUSY}$  pin is provided on each port. Two Interrupt ( $\overline{INT}$ ) pins can be used for port to port communication. Two Semaphore ( $\overline{SEM}$ ) control pins are used for allocating shared resources. With the  $M/\overline{S}$  pin, the devices can function as a master ( $\overline{BUSY}$  pins are outputs) or as a slave ( $\overline{BUSY}$  pins are inputs). They also have an automatic power down feature controlled by  $\overline{CE}$ . Each port has its own output enable control ( $\overline{OE}$ ), which enables data to be read from the device.

## Functional Description

The CY7C024AV/024BV/025AV/026AV and CY7C0241AV/0251AV/036AV are low power CMOS 4K, 8K, and 16K x16/18 dual port static RAMs. Various arbitration schemes are included on the devices to handle situations when multiple processors access the same piece of data. There are two ports permitting independent, asynchronous access for reads and writes to any location in memory. The devices can be used as standalone 16 or 18-bit dual port static RAMs or multiple devices can be combined to function as a 32 or 36-bit or wider master and slave dual port static RAM. An  $M/\overline{S}$  pin is provided for implementing 32 or 36-bit or wider memory applications. It does not need separate master and slave devices or additional discrete logic. Application areas include interprocessor/multiprocessor designs, communications status buffering, and dual port video and graphics memory.

Each port has independent control pins: Chip Enable ( $\overline{CE}$ ), Read or Write Enable ( $R/\overline{W}$ ), and Output Enable ( $\overline{OE}$ ). Two flags are provided on each port ( $\overline{BUSY}$  and  $\overline{INT}$ ).  $\overline{BUSY}$  signals that the port is trying to access the same location currently being

accessed by the other port. The Interrupt flag ( $\overline{INT}$ ) permits communication between ports or systems by means of a mail box. The semaphores are used to pass a flag, or token, from one port to the other to indicate that a shared resource is in use. The semaphore logic has eight shared latches. Only one side can control the latch (semaphore) at any time. Control of a semaphore indicates that a shared resource is in use. An automatic power down feature is controlled independently on each port by a Chip Select ( $\overline{CE}$ ) pin.

The CY7C024AV/024BV/025AV/026AV and CY7C0241AV/0251AV/036AV are available in 100-pin Pb-free Thin Quad Flat Pack (TQFP) and 100-pin TQFP.

## Write Operation

Data must be set up for a duration of  $t_{SD}$  before the rising edge of  $R/W$  to guarantee a valid write. A write operation is controlled by either the  $R/W$  pin (see Figure 8 on page 12) or the  $\overline{CE}$  pin (see Figure 9 on page 12). Required inputs for non-contention operations are summarized in Table 1 on page 7.

If a location is being written to by one port and the opposite port tries to read that location, there must be a port to port flowthrough delay before the data is read on the output; otherwise the data read is not deterministic. Data is valid on the port  $t_{DDD}$  after the data is presented on the other port.

## Read Operation

When reading the device, the user must assert both the  $\overline{OE}$  and  $\overline{CE}$  pins. Data is available  $t_{ACE}$  after  $\overline{CE}$  or  $t_{DOE}$  after  $\overline{OE}$  is asserted. If the user wants to access a semaphore flag, then the  $\overline{SEM}$  pin and  $\overline{OE}$  must be asserted.

## Interrupts

The upper two memory locations are for message passing. The highest memory location (FFF for the CY7C024AV/024BV/41AV/1FFF for the CY7C025AV/51AV,

3FFF for the CY7C026AV/36AV) is the mailbox for the right port and the second highest memory location (FFE for the CY7C024AV/024BV/41AV/1FFE for the CY7C025AV/51AV, 3FFE for the CY7C026AV/36AV) is the mailbox for the left port. When one port writes to the other port's mailbox, an interrupt is generated to the owner. The interrupt is reset when the owner reads the contents of the mailbox. The message is user defined.

Each port can read the other port's mailbox without resetting the interrupt. The active state of the busy signal (to a port) prevents the port from setting the interrupt to the winning port. Also, an active busy to a port prevents that port from reading its own mailbox and, thus, resetting the interrupt to it.

If an application does not require message passing, do not connect the interrupt pin to the processor's interrupt request input pin.

The operation of the interrupts and their interaction with Busy are summarized in [Table 2](#) on page 7.

### Busy

The CY7C024AV/024BV/025AV/026AV and CY7C0241AV/0251AV/036AV provide on-chip arbitration to resolve simultaneous memory location access (contention). If both ports'  $\overline{CE}$ s are asserted and an address match occurs within  $t_{PS}$  of each other, the busy logic determines which port has access. If  $t_{PS}$  is violated, one port definitely gains permission to the location, but it is not predictable which port gets that permission.  $\overline{BUSY}$  is asserted  $t_{BLA}$  after an address match or  $t_{BLC}$  after  $\overline{CE}$  is taken LOW.

### Master/Slave

A  $\overline{M/S}$  pin helps to expand the word width by configuring the device as a master or a slave. The  $\overline{BUSY}$  output of the master is connected to the  $\overline{BUSY}$  input of the slave. This enables the device to interface to a master device with no external components. Writing to slave devices must be delayed until after the  $\overline{BUSY}$  input has settled ( $t_{BLC}$  or  $t_{BLA}$ ). Otherwise, the slave chip may begin a write cycle during a contention situation. When tied HIGH, the  $\overline{M/S}$  pin enables the device to be used as a master and, therefore, the  $\overline{BUSY}$  line is an output.  $\overline{BUSY}$  can then be used to send the arbitration outcome to a slave.

### Semaphore Operation



The CY7C024AV/024BV/025AV/026AV and CY7C0241AV/0251AV/036AV provide eight semaphore latches, which are separate from the dual port memory locations. Semaphores are used to reserve resources that are shared between the two ports. The state of the semaphore indicates that a resource is in use. For example, if the left port wants to request a given resource, it sets a latch by writing a zero to a semaphore location. The left port then verifies its success in setting the latch by reading it. After writing to the semaphore,  $\overline{SEM}$  or  $\overline{OE}$  must be deasserted for  $t_{SOP}$  before attempting to read the semaphore. The semaphore value is available  $t_{SWRD} + t_{DOE}$  after the rising edge of the semaphore write. If the left port was successful (reads a zero), it assumes control of the shared resource. Otherwise (reads a one), it assumes the right port has control and continues to poll the semaphore. When the right side has relinquished control of the semaphore (by writing a one), the left side succeeds in gaining control of the semaphore. If the left side no longer requires the semaphore, a one is written to cancel its request.

Semaphores are accessed by asserting  $\overline{SEM}$  LOW. The  $\overline{SEM}$  pin functions as a chip select for the semaphore latches ( $\overline{CE}$  must remain HIGH during  $\overline{SEM}$  LOW).  $A_{0-2}$  represents the semaphore address.  $\overline{OE}$  and  $\overline{RW}$  are used in the same manner as a normal memory access. When writing or reading a semaphore, the other address pins have no effect.

When writing to the semaphore, only  $IO_0$  is used. If a zero is written to the left port of an available semaphore, a one appears at the same semaphore address on the right port. That semaphore can now only be modified by the side showing zero (the left port in this case). If the left port now relinquishes control by writing a one to the semaphore, the semaphore is set to one for both sides. However, if the right port had requested the semaphore (written a zero) while the left port had control, the right port would immediately own the semaphore as soon as the left port released it. [Table 3](#) on page 7 shows sample semaphore operations.

When reading a semaphore, all 16 and 18 data lines output the semaphore value. The read value is latched in an output register to prevent the semaphore from changing state during a write from the other port. If both ports attempt to access the semaphore within  $t_{SPS}$  of each other, the semaphore is definitely obtained by one of them. But there is no guarantee which side controls the semaphore.

**Table 1. Non-Contending Read/Write**

Inputs						Outputs		Operation
CE	R/W	OE	UB	LB	SEM	IO <sub>9</sub> -IO <sub>17</sub>	IO <sub>0</sub> -IO <sub>8</sub>	
H	X	X	X	X	H	High Z	High Z	Deselected: Power Down
X	X	X	H	H	H	High Z	High Z	Deselected: Power Down
L	L	X	L	H	H	Data In	High Z	Write to Upper Byte Only
L	L	X	H	L	H	High Z	Data In	Write to Lower Byte Only
L	L	X	L	L	H	Data In	Data In	Write to Both Bytes
L	H	L	L	H	H	Data Out	High Z	Read Upper Byte Only
L	H	L	H	L	H	High Z	Data Out	Read Lower Byte Only
L	H	L	L	L	H	Data Out	Data Out	Read Both Bytes
X	X	H	X	X	X	High Z	High Z	Outputs Disabled
H	H	L	X	X	L	Data Out	Data Out	Read Data in Semaphore Flag
X	H	L	H	H	L	Data Out	Data Out	Read Data in Semaphore Flag
H		X	X	X	L	Data In	Data In	Write D <sub>IN0</sub> into Semaphore Flag
X		X	H	H	L	Data In	Data In	Write D <sub>IN0</sub> into Semaphore Flag
L	X	X	L	X	L			Not Allowed
L	X	X	X	L	L			Not Allowed

**Table 2. Interrupt Operation Example (assumes  $\overline{\text{BUSY}}_L = \overline{\text{BUSY}}_R = \text{HIGH}$ )<sup>[10]</sup>**

Function	Left Port					Right Port				
	R/W <sub>L</sub>	CE <sub>L</sub>	OE <sub>L</sub>	A <sub>0L-13L</sub>	INT <sub>L</sub>	R/W <sub>R</sub>	CE <sub>R</sub>	OE <sub>R</sub>	A <sub>0R-13R</sub>	INT <sub>R</sub>
Set Right $\overline{\text{INT}}_R$ Flag	L	L	X	FFF <sup>[13]</sup>	X	X	X	X	X	L <sup>[12]</sup>
Reset Right $\overline{\text{INT}}_R$ Flag	X	X	X	X	X	X	L	L	FFF (or 1/3FFF)	H <sup>[11]</sup>
Set Left $\overline{\text{INT}}_L$ Flag	X	X	X	X	L <sup>[11]</sup>	L	L	X	1FFE (or 1/3FFE)	X
Reset Left $\overline{\text{INT}}_L$ Flag	X	L	L	1FFE <sup>[13]</sup>	H <sup>[12]</sup>	X	X	X	X	X

**Table 3. Semaphore Operation Example**

Function	IO <sub>0</sub> -IO <sub>17</sub> Left	IO <sub>0</sub> -IO <sub>17</sub> Right	Status
No action	1	1	Semaphore-free
Left port writes 0 to semaphore	0	1	Left Port has semaphore token
Right port writes 0 to semaphore	0	1	No change. Right side has no write access to semaphore
Left port writes 1 to semaphore	1	0	Right port obtains semaphore token
Left port writes 0 to semaphore	1	0	No change. Left port has no write access to semaphore
Right port writes 1 to semaphore	0	1	Left port obtains semaphore token
Left port writes 1 to semaphore	1	1	Semaphore-free
Right port writes 0 to semaphore	1	0	Right port has semaphore token
Right port writes 1 to semaphore	1	1	Semaphore free
Left port writes 0 to semaphore	0	1	Left port has semaphore token
Left port writes 1 to semaphore	1	1	Semaphore-free

**Notes**

- 10. See [Functional Description](#) on page 5 for specific highest memory locations by device.
- 11. If  $\overline{\text{BUSY}}_R=L$ , then no change.
- 12. If  $\overline{\text{BUSY}}_L=L$ , then no change.
- 13. See [Functional Description](#) on page 5 for specific addresses by device.

## Maximum Ratings

Exceeding maximum ratings<sup>[14]</sup> may shorten the useful life of the device. User guidelines are not tested.

Storage Temperature ..... -65°C to +150°C  
 Ambient Temperature with  
 Power Applied ..... -55°C to +125°C  
 Supply Voltage to Ground Potential ..... -0.5V to +4.6V  
 DC Voltage Applied to  
 Outputs in High-Z State ..... -0.5V to  $V_{CC} + 0.5V$

DC Input Voltage<sup>[15]</sup> ..... -0.5V to  $V_{CC} + 0.5V$   
 Output Current into Outputs (LOW) ..... 20 mA  
 Static Discharge Voltage ..... > 2001V  
 Latch-up Current ..... > 200 mA

## Operating Range

Range	Ambient Temperature	$V_{CC}$
Commercial	0°C to +70°C	3.3V ± 300 mV
Industrial <sup>[16]</sup>	-40°C to +85°C	3.3V ± 300 mV

## Electrical Characteristics

Over the Operating Range

Parameter	Description	CY7C024AV/024BV/025AV/026AV CY7C0241AV/0251AV/036AV						Unit	
		-20			-25				
		Min	Typ	Max	Min	Typ	Max		
$V_{OH}$	Output HIGH Voltage ( $V_{CC}=3.3V$ )	2.4			2.4			V	
$V_{OL}$	Output LOW Voltage			0.4			0.4	V	
$V_{IH}$	Input HIGH Voltage	2.0			2.0			V	
$V_{IL}$	Input LOW Voltage	-0.3 <sup>[17]</sup>		0.8			0.8	V	
$I_{OZ}$	Output Leakage Current	-10		10	-10		10	μA	
$I_{IX}$	Input Leakage Current	-10		10	-10		10	μA	
$I_{CC}$	Operating Current ( $V_{CC} = \text{Max.}$ , $I_{OUT} = 0 \text{ mA}$ ) Outputs Disabled	Com'l.	120	175			115	165	mA
		Ind. <sup>[16]</sup>					135	185	mA
$I_{SB1}$	Standby Current (Both Ports TTL Level) $CE_L \ \& \ CE_R \geq V_{IH}$ , $f = f_{MAX}$	Com'l.	35	45			30	40	mA
		Ind. <sup>[16]</sup>					40	50	mA
$I_{SB2}$	Standby Current (One Port TTL Level) $CE_L \   \ CE_R \geq V_{IH}$ , $f = f_{MAX}$	Com'l.	75	110			65	95	mA
		Ind. <sup>[16]</sup>					75	105	mA
$I_{SB3}$	Standby Current (Both Ports CMOS Level) $CE_L \ \& \ CE_R \geq V_{CC}-0.2V$ , $f = 0$	Com'l.	10	500			10	500	μA
		Ind. <sup>[16]</sup>					10	500	μA
$I_{SB4}$	Standby Current (One Port CMOS Level) $CE_L \   \ CE_R \geq V_{IH}$ , $f = f_{MAX}$ <sup>[18]</sup>	Com'l.	70	95			60	80	mA
		Ind. <sup>[16]</sup>					70	90	mA

## Capacitance

Parameter <sup>[19]</sup>	Description	Test Conditions	Max	Unit
$C_{IN}$	Input Capacitance	$T_A = 25^\circ\text{C}$ , $f = 1 \text{ MHz}$ , $V_{CC} = 3.3V$	10	pF
$C_{OUT}$	Output Capacitance		10	pF

### Notes

14. The voltage on any input or IO pin cannot exceed the power pin during power up.
15. Pulse width < 20 ns.
16. Industrial parts are available in CY7C026AV and CY7C036AV only.
17.  $V_{IL} \geq -1.5V$  for pulse width less than 10ns.
18.  $f_{MAX} = 1/t_{RC}$  = All inputs cycling at  $f = 1/t_{RC}$  (except output enable).  $f = 0$  means no address or control lines change. This applies only to inputs at CMOS level standby  $I_{SB3}$ .
19. Tested initially and after any design or process changes that may affect these parameters.



**Figure 4. AC Test Loads and Waveforms**

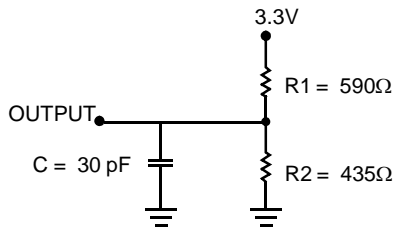

(a) Normal Load (Load 1)

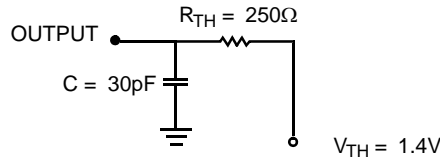

(b) Thévenin Equivalent (Load 1)

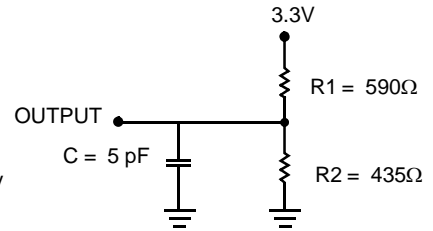

(c) Three-State Delay (Load 2)  
(Used for  $t_{LZ}$ ,  $t_{HZ}$ ,  $t_{HZWE}$ , and  $t_{LZWE}$  including scope and jig)

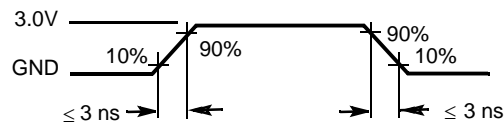

## Switching Characteristics

Over the Operating Range <sup>[20]</sup>

Parameter	Description	CY7C024AV/024BV/025AV/026AV CY7C0241AV/0251AV/036AV				Unit
		-20		-25		
		Min	Max	Min	Max	
<b>Read Cycle</b>						
$t_{RC}$	Read Cycle Time	20		25		ns
$t_{AA}$	Address to Data Valid		20		25	ns
$t_{OHA}$	Output Hold From Address Change	3		3		ns
$t_{ACE}^{[21]}$	CE LOW to Data Valid		20		25	ns
$t_{DOE}$	OE LOW to Data Valid		12		13	ns
$t_{LZOE}^{[22, 23, 24]}$	OE Low to Low Z	3		3		ns
$t_{HZOE}^{[22, 23, 24]}$	OE HIGH to High Z		12		15	ns
$t_{LZCE}^{[22, 23, 24]}$	CE LOW to Low Z	3		3		ns
$t_{HZCE}^{[22, 23, 24]}$	CE HIGH to High Z		12		15	ns
$t_{PU}^{[24]}$	CE LOW to Power Up	0		0		ns
$t_{PD}^{[24]}$	CE HIGH to Power Down		20		25	ns
$t_{ABE}^{[21]}$	Byte Enable Access Time		20		25	ns
<b>Write Cycle</b>						
$t_{WC}$	Write Cycle Time	20		25		ns
$t_{SCE}^{[21]}$	CE LOW to Write End	15		20		ns
$t_{AW}$	Address Valid to Write End	15		20		ns
$t_{HA}$	Address Hold From Write End	0		0		ns
$t_{SA}^{[21]}$	Address Setup to Write Start	0		0		ns

### Notes

20. Test conditions assume signal transition time of 3 ns or less, timing reference levels of 1.5V, input pulse levels of 0 to 3.0V, and output loading of the specified  $I_{OL}/I_{OH}$  and 30 pF load capacitance.

21. To access RAM,  $\overline{CE} = L$ ,  $\overline{UB} = L$ ,  $\overline{SEM} = H$ . To access semaphore,  $\overline{CE} = H$  and  $\overline{SEM} = L$ . Either condition must be valid for the entire  $t_{SCE}$  time.

22. At any given temperature and voltage condition for any given device,  $t_{HZCE}$  is less than  $t_{LZCE}$  and  $t_{HZOE}$  is less than  $t_{LZOE}$ .

23. Test conditions used are Load 3.

24. This parameter is guaranteed but not tested. For information on port to port delay through RAM cells from writing port to reading port, refer to [Figure 12](#).

## Switching Characteristics

Over the Operating Range (continued)<sup>[20]</sup>

Parameter	Description	CY7C024AV/024BV/025AV/026AV CY7C0241AV/0251AV/036AV				Unit
		-20		-25		
		Min	Max	Min	Max	
t <sub>PWE</sub>	Write Pulse Width	15		20		ns
t <sub>SD</sub>	Data Setup to Write End	15		15		ns
t <sub>HD</sub>	Data Hold From Write End	0		0		ns
t <sub>HZWE</sub> <sup>[23, 24]</sup>	R/W LOW to High Z		12		15	ns
t <sub>LZWE</sub> <sup>[23, 24]</sup>	R/W HIGH to Low Z	3		0		ns
t <sub>WDD</sub> <sup>[25]</sup>	Write Pulse to Data Delay		45		50	ns
t <sub>DDD</sub> <sup>[25]</sup>	Write Data Valid to Read Data Valid		30		35	ns
<b>Busy Timing</b> <sup>[26]</sup>						
t <sub>BLA</sub>	BUSY LOW from Address Match		20		20	ns
t <sub>BHA</sub>	BUSY HIGH from Address Mismatch		20		20	ns
t <sub>BLC</sub>	BUSY LOW from CE LOW		20		20	ns
t <sub>BHC</sub>	BUSY HIGH from CE HIGH		17		17	ns
t <sub>PS</sub>	Port Setup for Priority	5		5		ns
t <sub>WB</sub>	R/W HIGH after BUSY (Slave)	0		0		ns
t <sub>WH</sub>	R/W HIGH after BUSY HIGH (Slave)	15		17		ns
t <sub>BDD</sub> <sup>[27]</sup>	BUSY HIGH to Data Valid		20		25	ns
<b>Interrupt Timing</b> <sup>[26]</sup>						
t <sub>INS</sub>	INT Set Time		20		20	ns
t <sub>INR</sub>	INT Reset Time		20		20	ns
<b>Semaphore Timing</b>						
t <sub>SOP</sub>	SEM Flag Update Pulse (OE or SEM)	10		12		ns
t <sub>SWRD</sub>	SEM Flag Write to Read Time	5		5		ns
t <sub>SPS</sub>	SEM Flag Contention Window	5		5		ns
t <sub>SAA</sub>	SEM Address Access Time		20		25	ns

## Data Retention Mode

The CY7C024AV/024BV/025AV/026AV and CY7C0241AV/0251AV/036AV are designed for battery backup. Data retention voltage and supply current are guaranteed over temperature. The following rules ensure data retention:

1. Chip Enable ( $\overline{CE}$ ) must be held HIGH during data retention, within  $V_{CC}$  to  $V_{CC} - 0.2V$ .
2.  $\overline{CE}$  must be kept between  $V_{CC} - 0.2V$  and 70 percent of  $V_{CC}$  during the power up and power down transitions.
3. The RAM can begin operation  $>t_{RC}$  after  $V_{CC}$  reaches the minimum operating voltage (3.0V).

## Timing

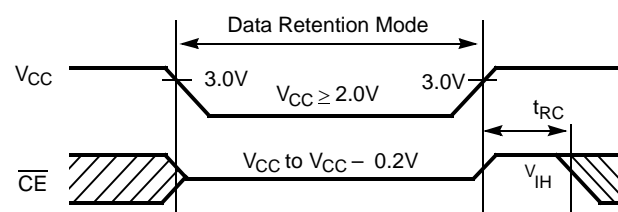

Parameter	Test Conditions <sup>[28]</sup>	Max	Unit
I <sub>CCDR1</sub>	at V <sub>CCDR</sub> = 2V	50	μA

### Notes

25. For information on port to port delay through RAM cells from writing port to reading port, refer to Figure 12.
26. Test conditions used are Load 2.
27. t<sub>BDD</sub> is a calculated parameter and is the greater of t<sub>WDD</sub> - t<sub>PWE</sub> (actual) or t<sub>DDD</sub> - t<sub>SD</sub> (actual).
28. CE = V<sub>CC</sub>; V<sub>in</sub> = GND to V<sub>CC</sub>; T<sub>A</sub> = 25°C. This parameter is guaranteed but not tested.

## Switching Waveforms

Figure 5. Read Cycle No. 1 (Either Port Address Access)<sup>[29, 30, 31]</sup>

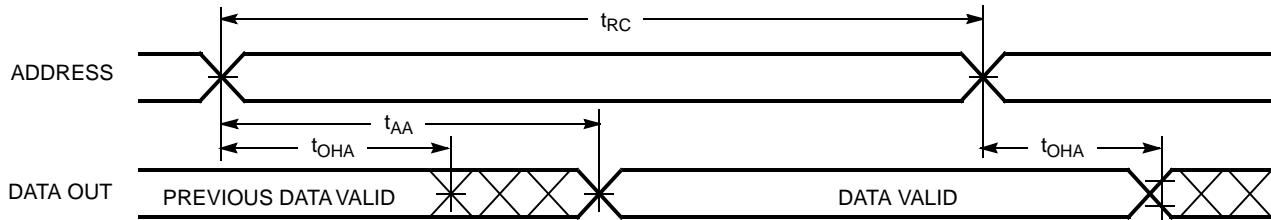

Figure 6. Read Cycle No. 2 (Either Port  $\overline{\text{CE/OE}}$  Access)<sup>[29, 32, 33]</sup>

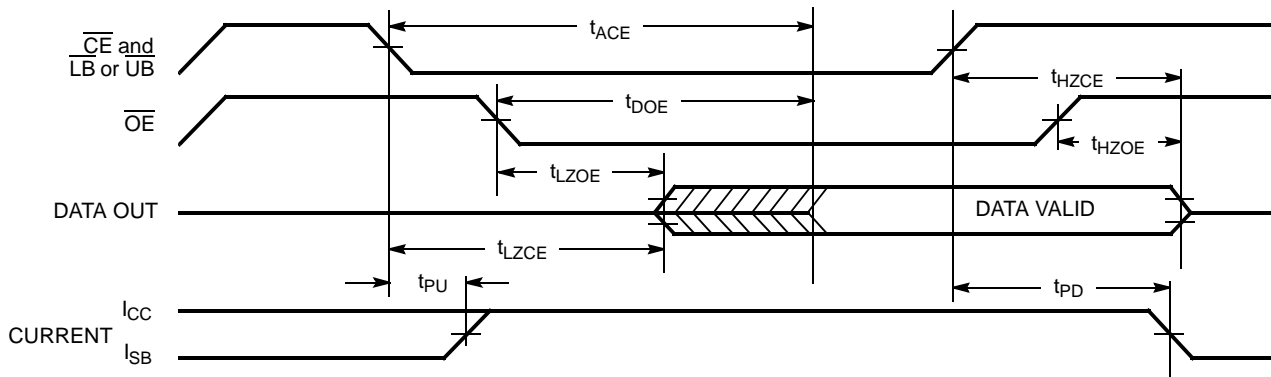
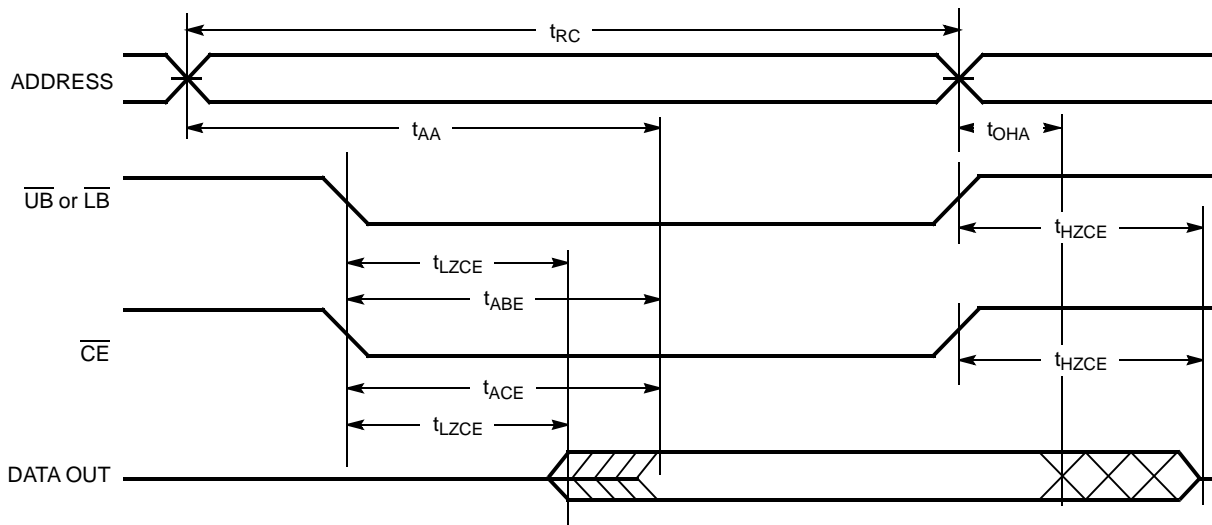

Figure 7. Read Cycle No. 3 (Either Port)<sup>[29, 31, 32, 33]</sup>



### Notes

29. R/W is HIGH for read cycles.
30. Device is continuously selected  $\overline{\text{CE}} = V_{IL}$  and  $\overline{\text{UB}}$  or  $\overline{\text{LB}} = V_{IL}$ . This waveform cannot be used for semaphore reads.
31.  $\overline{\text{OE}} = V_{IL}$ .
32. Address valid prior to or coincident with  $\overline{\text{CE}}$  transition LOW.
33. To access RAM,  $\overline{\text{CE}} = V_{IL}$ ,  $\overline{\text{UB}}$  or  $\overline{\text{LB}} = V_{IL}$ ,  $\overline{\text{SEM}} = V_{IH}$ . To access semaphore,  $\overline{\text{CE}} = V_{IH}$ ,  $\overline{\text{SEM}} = V_{IL}$ .

Switching Waveforms (continued)

Figure 8. Write Cycle No. 1:  $\overline{R/W}$  Controlled Timing<sup>[34, 35, 36, 37]</sup>

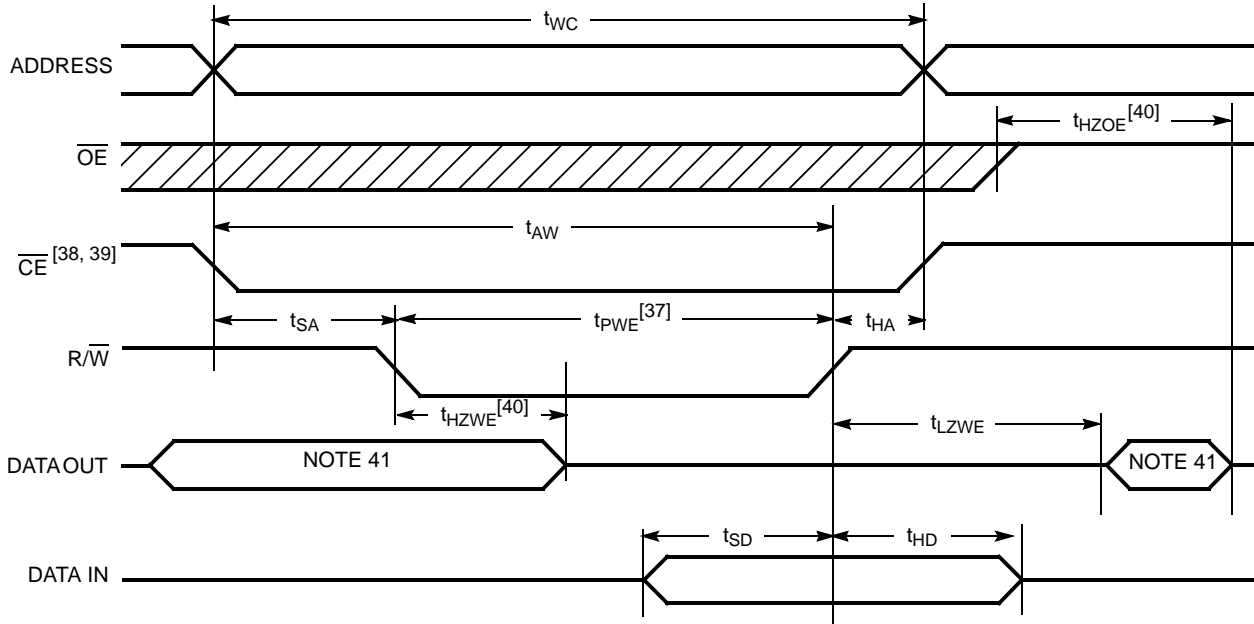
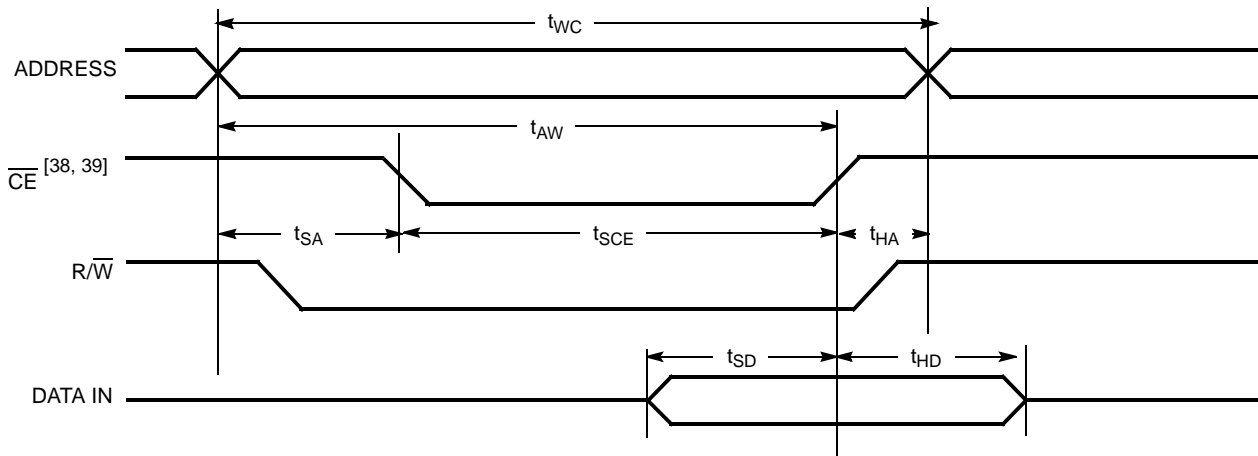

Figure 9. Write Cycle No. 2:  $\overline{CE}$  Controlled Timing<sup>[34, 35, 36, 42]</sup>



Notes

34.  $\overline{R/W}$  or  $\overline{CE}$  must be HIGH during all address transitions.
35. A write occurs during the overlap ( $t_{SCE}$  or  $t_{PWE}$ ) of a LOW  $\overline{CE}$  or  $\overline{SEM}$  and a LOW  $\overline{UB}$  or  $\overline{LB}$ .
36.  $t_{HA}$  is measured from the earlier of  $\overline{CE}$  or  $\overline{R/W}$  or ( $\overline{SEM}$  or  $\overline{R/W}$ ) going HIGH at the end of write cycle.
37. If  $\overline{OE}$  is LOW during a  $\overline{R/W}$  controlled write cycle, the write pulse width must be the larger of  $t_{PWE}$  or ( $t_{HZWE} + t_{SD}$ ) to enable the IO drivers to turn off and data to be placed on the bus for the required  $t_{SD}$ . If  $\overline{OE}$  is HIGH during an  $\overline{R/W}$  controlled write cycle, this requirement does not apply and the write pulse can be as short as the specified  $t_{PWE}$ .
38. To access RAM,  $\overline{CE} = V_{IL}$ ,  $\overline{SEM} = V_{IH}$ .
39. To access upper byte,  $\overline{CE} = V_{IL}$ ,  $\overline{UB} = V_{IL}$ ,  $\overline{SEM} = V_{IH}$ .  
To access lower byte,  $\overline{CE} = V_{IL}$ ,  $\overline{LB} = V_{IL}$ ,  $\overline{SEM} = V_{IH}$ .
40. Transition is measured  $\pm 500$  mV from steady state with a 5 pF load (including scope and jig). This parameter is sampled and not 100 percent tested.
41. During this period, the IO pins are in the output state, and input signals must not be applied.
42. If the  $\overline{CE}$  or  $\overline{SEM}$  LOW transition occurs simultaneously with or after the  $\overline{R/W}$  LOW transition, the outputs remain in the high impedance state.

Switching Waveforms (continued)

Figure 10. Semaphore Read After Write Timing, Either Side<sup>[43]</sup>

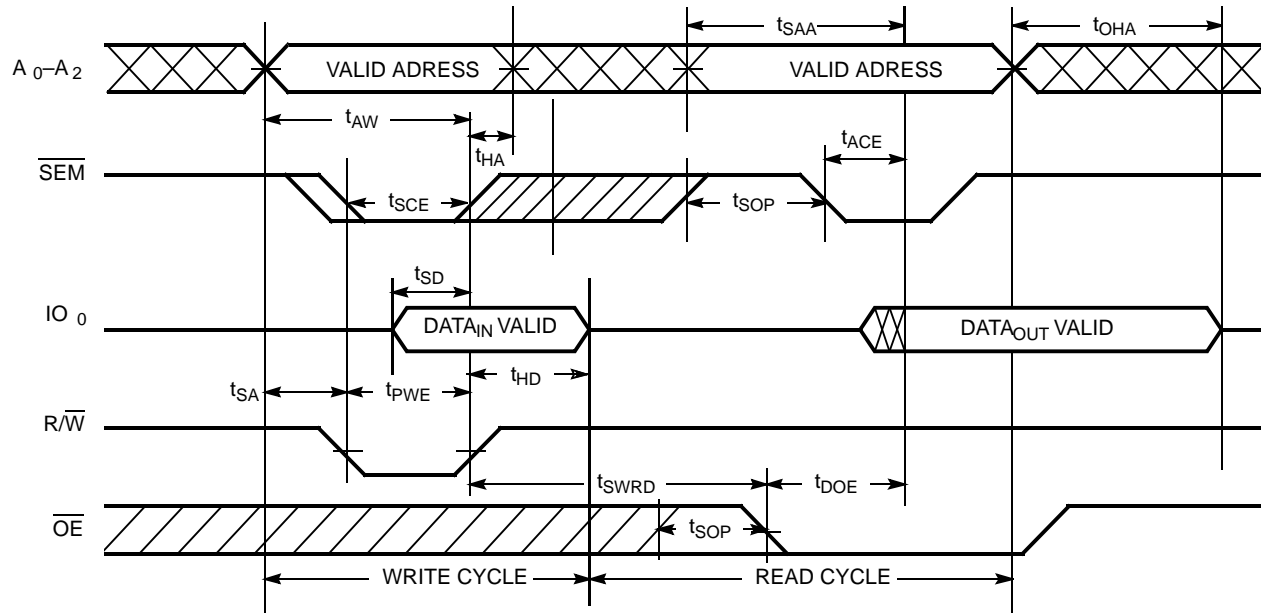
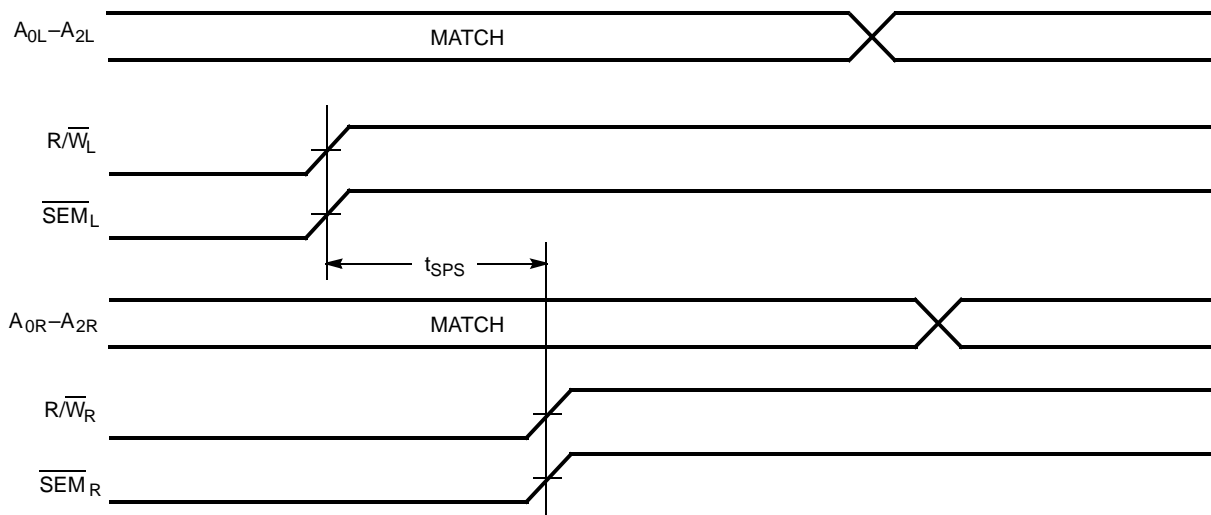

Figure 11. Timing Diagram of Semaphore Contention<sup>[44, 45, 46]</sup>



Notes

- 43. CE = HIGH for the duration of the above timing (both write and read cycle).
- 44. IO<sub>0R</sub> = IO<sub>0L</sub> = LOW (request semaphore); CE<sub>R</sub> = CE<sub>L</sub> = HIGH.
- 45. Semaphores are reset (available to both ports) at cycle start.
- 46. If t<sub>SPS</sub> is violated, the semaphore is definitely obtained by one side or the other, but which side gets the semaphore is unpredictable.

Switching Waveforms (continued)

Figure 12. Timing Diagram of Read with  $\overline{\text{BUSY}}$  ( $\overline{\text{M/S}}=\text{HIGH}$ )<sup>[47]</sup>

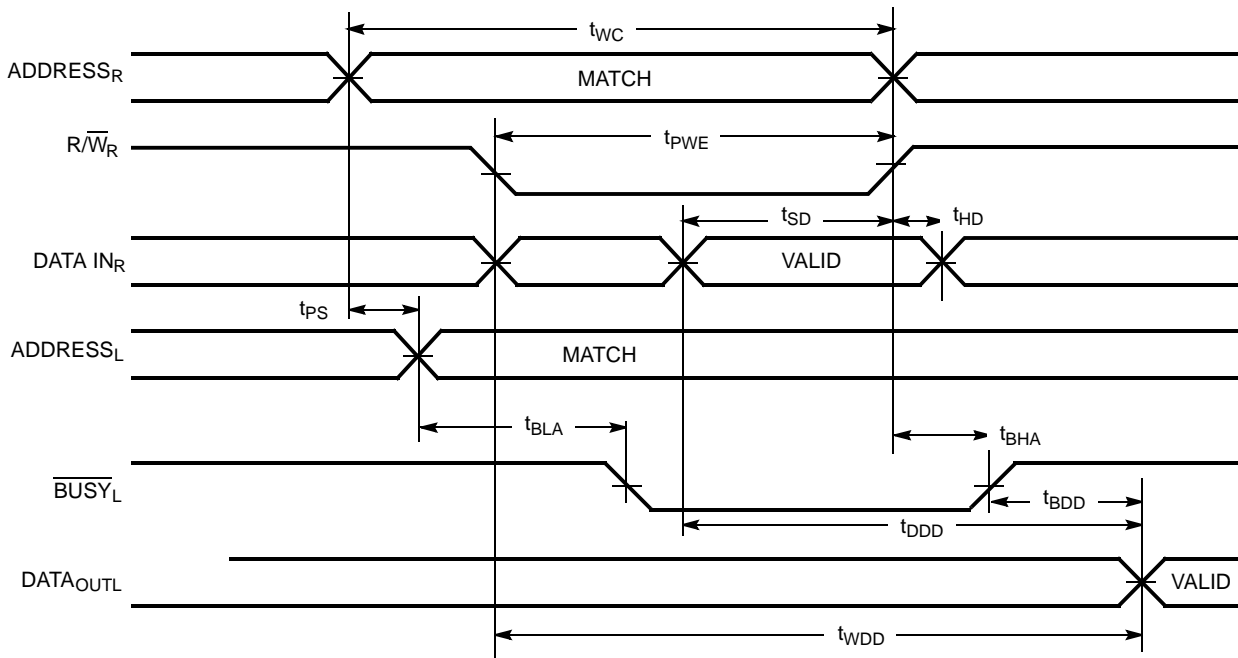
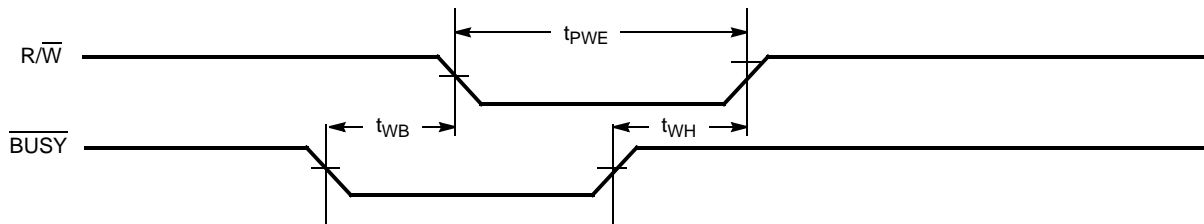

Figure 13. Write Timing with Busy Input ( $\overline{\text{M/S}}=\text{LOW}$ )



Note  
47.  $\overline{\text{CE}}_L = \overline{\text{CE}}_R = \text{LOW}$ .

Switching Waveforms (continued)

Figure 14. Busy Timing Diagram No.1 ( $\overline{CE}$  Arbitration)<sup>[48]</sup>

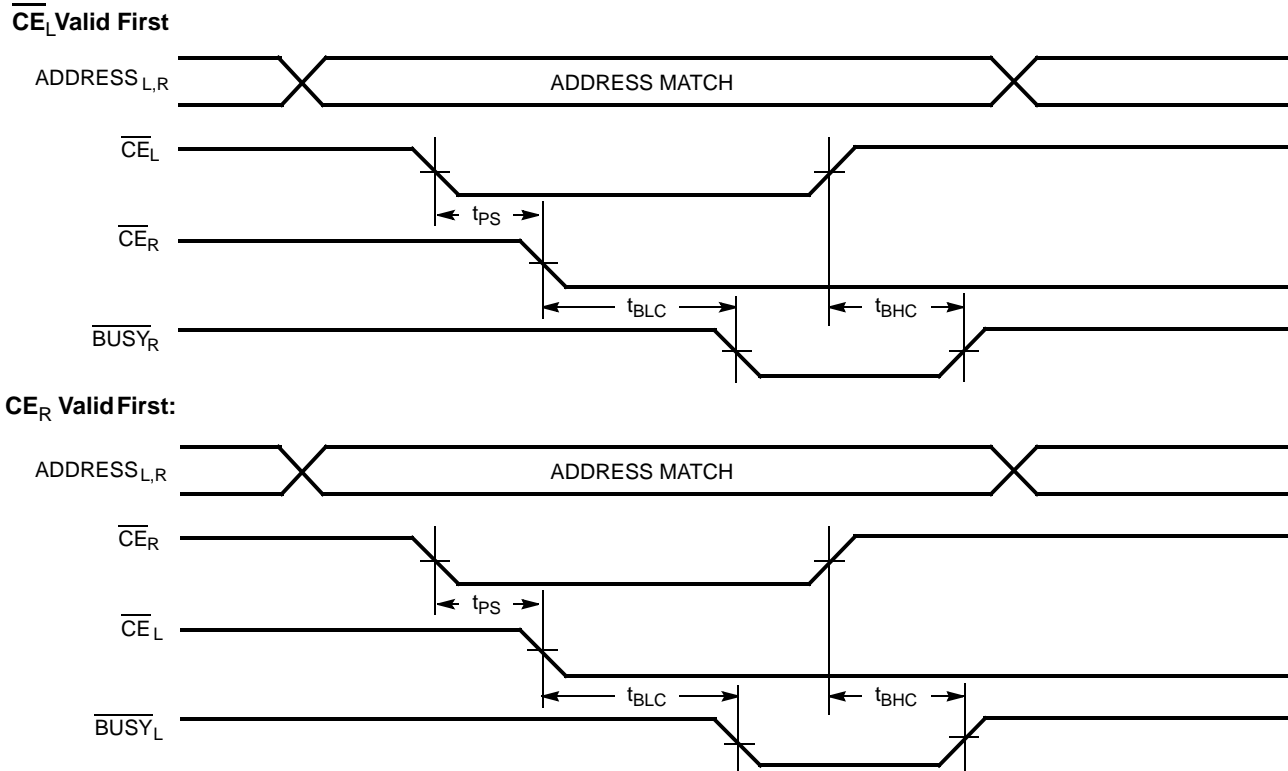
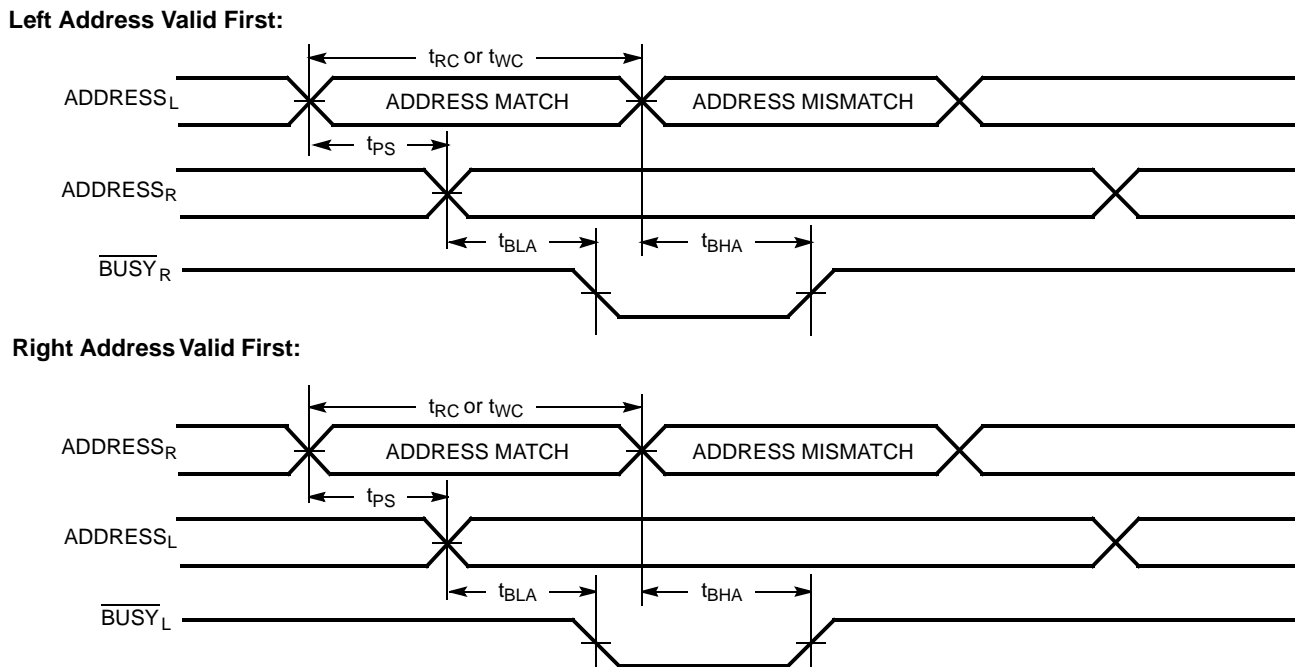

Figure 15. Busy Timing Diagram No.2 (Address Arbitration)<sup>[48]</sup>



Note

48. If  $t_{PS}$  is violated, the busy signal is asserted on one side or the other, but there is no guarantee to which side  $\overline{BUSY}$  is asserted.

Switching Waveforms (continued)

Figure 16. Interrupt Timing Diagram

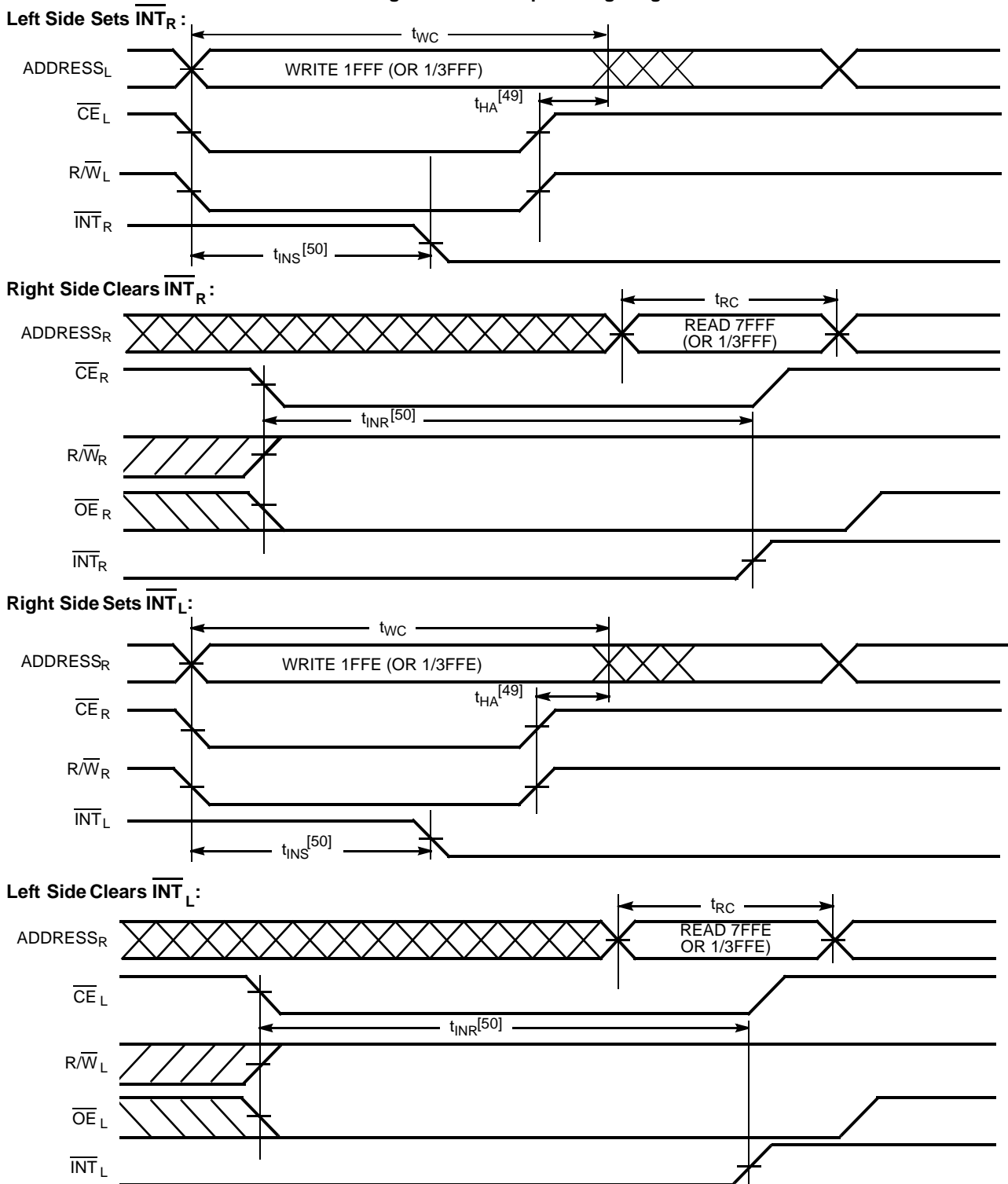

Notes

- 49.  $t_{HA}$  depends on which enable pin ( $\overline{\text{CE}}_L$  or  $\overline{\text{R}}/\overline{\text{W}}_L$ ) is deasserted first.
- 50.  $t_{INS}$  or  $t_{INR}$  depends on which enable pin ( $\overline{\text{CE}}_L$  or  $\overline{\text{R}}/\overline{\text{W}}_L$ ) is asserted last.



## Ordering Information

### 4K x16 3.3V Asynchronous Dual-Port SRAM

Speed (ns)	Ordering Code	Package Diagram	Package Type	Operating Range
15	CY7C024AV-15AI	51-85048	100-Pin Thin Quad Flat Pack	Industrial
	CY7C024BV-15AXI	51-85048	100-Pin Pb-Free Thin Quad Flat Pack	
20	CY7C024AV-20AC	51-85048	100-Pin Thin Quad Flat Pack	Commercial
	CY7C024AV-20AXC	51-85048	100-Pin Pb-Free Thin Quad Flat Pack	
	CY7C024AV-20AI	51-85048	100-Pin Thin Quad Flat Pack	Industrial
	CY7C024AV-20AXI	51-85048	100-Pin Pb-Free Thin Quad Flat Pack	
25	CY7C024AV-25AC	51-85048	100-Pin Thin Quad Flat Pack	Commercial
	CY7C024AV-25AXC	51-85048	100-Pin Pb-Free Thin Quad Flat Pack	
	CY7C024AV-25AI	51-85048	100-Pin Thin Quad Flat Pack	Industrial
	CY7C024AV-25AXI	51-85048	100-Pin Pb-Free Thin Quad Flat Pack	

### 8K x16 3.3V Asynchronous Dual-Port SRAM

Speed (ns)	Ordering Code	Package Name	Package Type	Operating Range
20	CY7C025AV-20AC	51-85048	100-Pin Thin Quad Flat Pack	Commercial
	CY7C025AV-20AXC	51-85048	100-Pin Pb-Free Thin Quad Flat Pack	
	CY7C025AV-20AXI	51-85048	100-Pin Pb-Free Thin Quad Flat Pack	Industrial
25	CY7C025AV-25AC	51-85048	100-Pin Thin Quad Flat Pack	Commercial
	CY7C025AV-25AXC	51-85048	100-Pin Pb-Free Thin Quad Flat Pack	
	CY7C025AV-25AI	51-85048	100-Pin Thin Quad Flat Pack	Industrial
	CY7C025AV-25AXI	51-85048	100-Pin Pb-Free Thin Quad Flat Pack	

### 16K x16 3.3V Asynchronous Dual-Port SRAM

Speed (ns)	Ordering Code	Package Name	Package Type	Operating Range
20	CY7C026AV-20AC	51-85048	100-Pin Thin Quad Flat Pack	Commercial
	CY7C026AV-20AXC	51-85048	100-Pin Pb-Free Thin Quad Flat Pack	
	CY7C026AV-20AXI	51-85048	100-Pin Pb-Free Thin Quad Flat Pack	Industrial
25	CY7C026AV-25AC	51-85048	100-Pin Thin Quad Flat Pack	Commercial
	CY7C026AV-25AXC	51-85048	100-Pin Pb-Free Thin Quad Flat Pack	
	CY7C026AV-25AI	51-85048	100-Pin Thin Quad Flat Pack	Industrial
	CY7C026AV-25AXI	51-85048	100-Pin Pb-Free Thin Quad Flat Pack	

### 4K x18 3.3V Asynchronous Dual-Port SRAM

Speed (ns)	Ordering Code	Package Name	Package Type	Operating Range
20	CY7C0241AV-20AC	51-85048	100-Pin Thin Quad Flat Pack	Commercial
25	CY7C0241AV-25AC	51-85048	100-Pin Thin Quad Flat Pack	Commercial

### 8K x18 3.3V Asynchronous Dual-Port SRAM

Speed (ns)	Ordering Code	Package Name	Package Type	Operating Range
20	CY7C0251AV-20AC	51-85048	100-Pin Thin Quad Flat Pack	Commercial
25	CY7C0251AV-25AC	51-85048	100-Pin Thin Quad Flat Pack	Commercial

**16K x18 3.3V Asynchronous Dual-Port SRAM**

Speed (ns)	Ordering Code	Package Name	Package Type	Operating Range
20	CY7C036AV-20AC	51-85048	100-Pin Thin Quad Flat Pack	Commercial
25	CY7C036AV-25AC	51-85048	100-Pin Thin Quad Flat Pack	Commercial
	CY7C036AV-25AXC	51-85048	100-Pin Pb-free Thin Quad Flat Pack	
	CY7C036AV-25AI	51-85048	100-Pin Thin Quad Flat Pack	Industrial

**Package Diagram**

**Figure 17. 100-Pin Pb-Free Thin Plastic Quad Flat Pack (TQFP) A100**

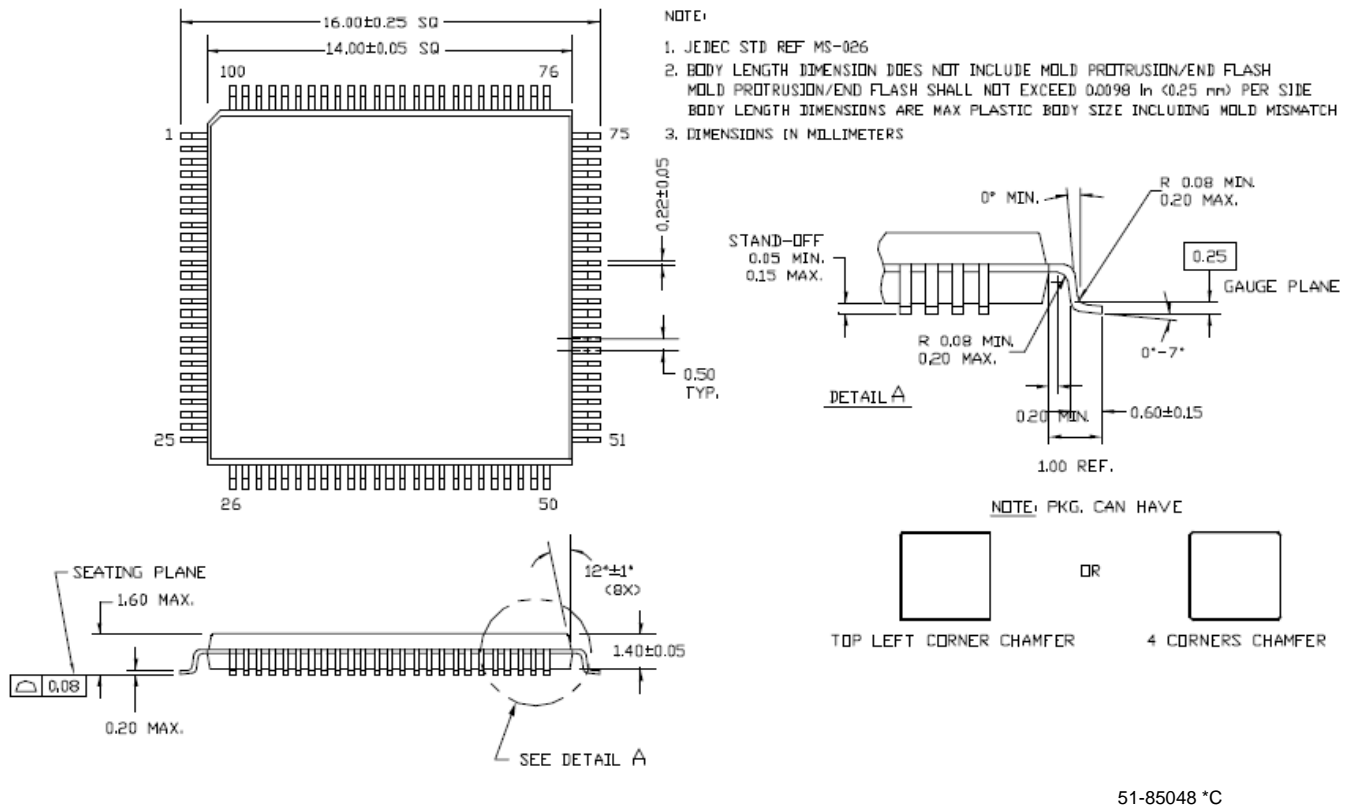

## Document History Page

Document Title: CY7C024AV/024BV/025AV/026AV, CY7C0241AV/0251AV/036AV 3.3V 4K/8K/16K x 16/18 Dual-Port Static RAM Document Number: 38-06052				
Rev.	ECN No.	Orig. of Change	Submission Date	Description of Change
**	110204	SZV	11/11/01	Change from Spec number: 38-00838 to 38-06052
*A	122302	RBI	12/27/02	Power up requirements added to Maximum Ratings Information
*B	128958	JFU	9/03/03	Added CY7C025AV-25AI to Ordering Information
*C	237622	YDT	See ECN	Removed cross information from features section
*D	241968	WWZ	See ECN	Added CY7C024AV-25AI to Ordering Information
*E	276451	SPN	See ECN	Corrected x18 for 026AV to x16
*F	279452	RUY	See ECN	Added Pb-free packaging information Corrected pin A113L to A13L on CY7C026AV pin list Added minimum $V_{IL}$ of 0.3V and note 16
*G	373580	RUY	See ECN	Corrected CY7C024AC-25AXC to CY7C024AV-25AXC in Ordering Information
*H	380476	PCX	See ECN	Added to Part Ordering information: CY7C024AV-15AI, CY7C024AV-15AXI, CY7C024AV-20AI, CY7C024AV-20AXI, CY7C025AV-20AXI, CY7C026AV-20AXI
*I	2543577	NXR/AESA	07/25/08	Updated note number 33 on page 12 from "R/W must be HIGH during all address transitions" to "R/W or CE must be HIGH during all address transitions"
*J	2623540	VKN/PYRS	12/17/08	Added CY7C024BV part

## Sales, Solutions, and Legal Information

### Worldwide Sales and Design Support

Cypress maintains a worldwide network of offices, solution centers, manufacturer's representatives, and distributors. To find the office closest to you, visit us at [cypress.com/sales](http://cypress.com/sales).

#### Products

PSoC	<a href="http://psoc.cypress.com">psoc.cypress.com</a>
Clocks & Buffers	<a href="http://clocks.cypress.com">clocks.cypress.com</a>
Wireless	<a href="http://wireless.cypress.com">wireless.cypress.com</a>
Memories	<a href="http://memory.cypress.com">memory.cypress.com</a>
Image Sensors	<a href="http://image.cypress.com">image.cypress.com</a>

#### PSoC Solutions

General	<a href="http://psoc.cypress.com/solutions">psoc.cypress.com/solutions</a>
Low Power/Low Voltage	<a href="http://psoc.cypress.com/low-power">psoc.cypress.com/low-power</a>
Precision Analog	<a href="http://psoc.cypress.com/precision-analog">psoc.cypress.com/precision-analog</a>
LCD Drive	<a href="http://psoc.cypress.com/lcd-drive">psoc.cypress.com/lcd-drive</a>
CAN 2.0b	<a href="http://psoc.cypress.com/can">psoc.cypress.com/can</a>
USB	<a href="http://psoc.cypress.com/usb">psoc.cypress.com/usb</a>

© Cypress Semiconductor Corporation, 2001-2008. The information contained herein is subject to change without notice. Cypress Semiconductor Corporation assumes no responsibility for the use of any circuitry other than circuitry embodied in a Cypress product. Nor does it convey or imply any license under patent or other rights. Cypress products are not warranted nor intended to be used for medical, life support, life saving, critical control or safety applications, unless pursuant to an express written agreement with Cypress. Furthermore, Cypress does not authorize its products for use as critical components in life-support systems where a malfunction or failure may reasonably be expected to result in significant injury to the user. The inclusion of Cypress products in life-support systems application implies that the manufacturer assumes all risk of such use and in doing so indemnifies Cypress against all charges.

Any Source Code (software and/or firmware) is owned by Cypress Semiconductor Corporation (Cypress) and is protected by and subject to worldwide patent protection (United States and foreign), United States copyright laws and international treaty provisions. Cypress hereby grants to licensee a personal, non-exclusive, non-transferable license to copy, use, modify, create derivative works of, and compile the Cypress Source Code and derivative works for the sole purpose of creating custom software and/or firmware in support of licensee product to be used only in conjunction with a Cypress integrated circuit as specified in the applicable agreement. Any reproduction, modification, translation, compilation, or representation of this Source Code except as specified above is prohibited without the express written permission of Cypress.

Disclaimer: CYPRESS MAKES NO WARRANTY OF ANY KIND, EXPRESS OR IMPLIED, WITH REGARD TO THIS MATERIAL, INCLUDING, BUT NOT LIMITED TO, THE IMPLIED WARRANTIES OF MERCHANTABILITY AND FITNESS FOR A PARTICULAR PURPOSE. Cypress reserves the right to make changes without further notice to the materials described herein. Cypress does not assume any liability arising out of the application or use of any product or circuit described herein. Cypress does not authorize its products for use as critical components in life-support systems where a malfunction or failure may reasonably be expected to result in significant injury to the user. The inclusion of Cypress' product in a life-support systems application implies that the manufacturer assumes all risk of such use and in doing so indemnifies Cypress against all charges.

Use may be limited by and subject to the applicable Cypress software license agreement.