

256K (32K x 8) Static RAM

Features

- **High Speed**
 - 70 ns
- **Temperature Ranges**
 - Commercial: 0°C to 70°C
 - Industrial: -40°C to 85°C
 - Automotive: -40°C to 125°C
- **Low voltage range:**
 - 2.7V – 3.6V
- **Low active power and standby power**
- **Easy memory expansion with \overline{CE} and \overline{OE} features**
- **TTL-compatible inputs and outputs**
- **Automatic power-down when deselected**
- **CMOS for optimum speed/power**
- **Available in a Pb-free and non Pb-free standard 28-pin narrow SOIC, 28-pin TSOP-1 and 28-pin Reverse TSOP-1 packages**

Functional Description^[1]

The CY62256V family is composed of two high-performance CMOS static RAM's organized as 32K words by 8 bits. Easy memory expansion is provided by an active LOW chip enable (\overline{CE}) and active LOW output enable (\overline{OE}) and Tri-state drivers. These devices have an automatic power-down feature, reducing the power consumption by over 99% when deselected.

An active LOW write enable signal (\overline{WE}) controls the writing/reading operation of the memory. When \overline{CE} and \overline{WE} inputs are both LOW, data on the eight data input/output pins (I/O_0 through I/O_7) is written into the memory location addressed by the address present on the address pins (A_0 through A_{14}). Reading the device is accomplished by selecting the device and enabling the outputs, \overline{CE} and \overline{OE} active LOW, while \overline{WE} remains inactive or HIGH. Under these conditions, the contents of the location addressed by the information on address pins are present on the eight data input/output pins.

The input/output pins remain in a high-impedance state unless the chip is selected, outputs are enabled, and write enable (\overline{WE}) is HIGH.

Logic Block Diagram

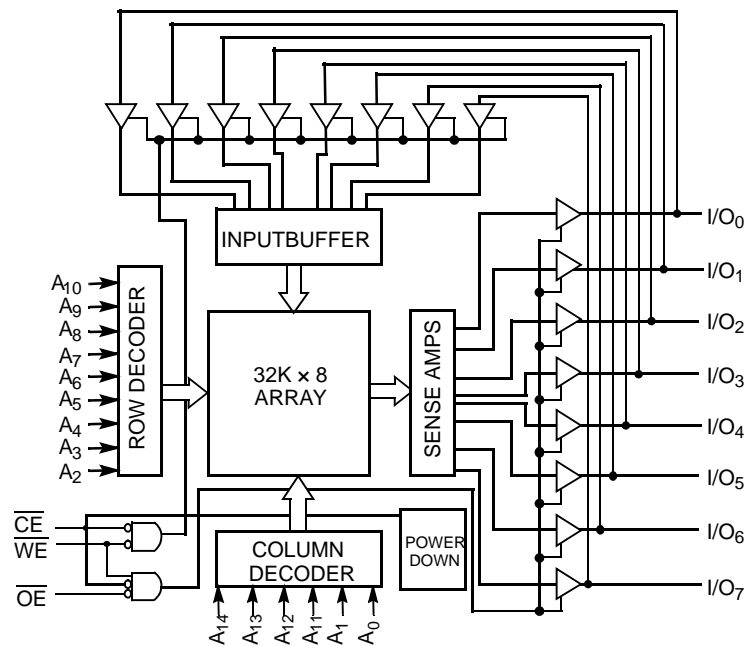

Note:

1. For best practice recommendations, please refer to the Cypress application note "System Design Guidelines" on <http://www.cypress.com>.

Product Portfolio

Product	Range	V _{CC} Range (V)			Speed (ns)	Power Dissipation			
		Min.	Typ. ^[2]	Max.		Operating, I _{CC} (mA)		Standby, I _{SB2} (μA)	
						Typ. ^[2]	Max.	Typ. ^[2]	Max.
CY62256VLL	Com'l/Ind'l	2.7	3.0	3.6	70	11	30	0.1	5
	Automotive								130

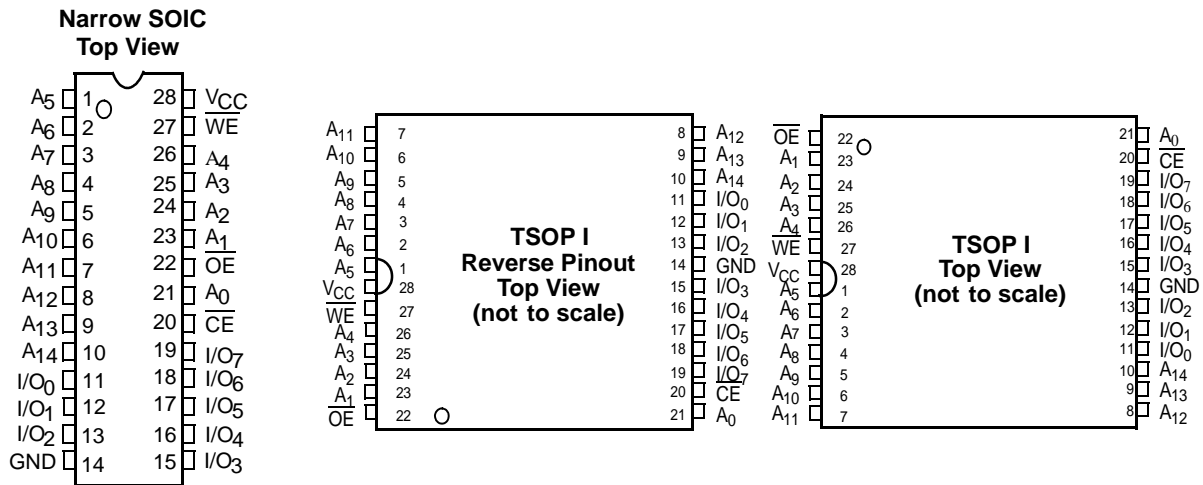
Pin Configurations

Pin Definitions

Pin Number	Type	Description
1–10, 21, 23–26	Input	A₀–A₁₄ . Address Inputs
11–13, 15–19	Input/Output	I/O₀–I/O₇ . Data lines. Used as input or output lines depending on operation
27	Input/Control	\overline{WE} . When selected LOW, a WRITE is conducted. When selected HIGH, a READ is conducted
20	Input/Control	\overline{CE} . When LOW, selects the chip. When HIGH, deselects the chip
22	Input/Control	\overline{OE} . Output Enable. Controls the direction of the I/O pins. When LOW, the I/O pins behave as outputs. When deasserted HIGH, I/O pins are Tri-stated, and act as input data pins
14	Ground	GND . Ground for the device
28	Power Supply	V_{CC} . Power supply for the device

Note:

2. Typical values are included for reference only and are not guaranteed or tested. Typical values are measured at V_{CC} = V_{CC(typ.)}, T_A = 25°C, and t_{AA} = 70 ns.

Maximum Ratings

(Above which the useful life may be impaired. For user guidelines, not tested.)

Storage Temperature -65°C to +150°C
 Ambient Temperature with Power Applied..... -55°C to +125°C
 Supply Voltage to Ground Potential (Pin 28 to Pin 14) -0.5V to +4.6V
 DC Voltage Applied to Outputs in High-Z State^[3] -0.5V to $V_{CC} + 0.5V$
 DC Input Voltage^[3] -0.5V to $V_{CC} + 0.5V$

Output Current into Outputs (LOW)..... 20 mA
 Static Discharge Voltage..... > 2001V (per MIL-STD-883, Method 3015)
 Latch-up Current..... > 200 mA

Operating Range

Device	Range	Ambient Temperature (T_A) ^[4]	V_{CC}
CY62256V	Commercial	0°C to +70°C	2.7V to 3.6V
	Industrial	-40°C to +85°C	
	Automotive	-40°C to +125°C	

Electrical Characteristics Over the Operating Range

Parameter	Description	Test Conditions	CY62256V-70			Unit	
			Min.	Typ. ^[2]	Max.		
V_{OH}	Output HIGH Voltage	$I_{OH} = -1.0 \text{ mA}$, $V_{CC} = 2.7V$	2.4			V	
V_{OL}	Output LOW Voltage	$I_{OL} = 2.1 \text{ mA}$, $V_{CC} = 2.7V$			0.4	V	
V_{IH}	Input HIGH Voltage		2.2		$V_{CC} + 0.3V$	V	
V_{IL}	Input LOW Voltage		-0.5		0.8	V	
I_{IX}	Input Leakage Current	$GND \leq V_{IN} \leq V_{CC}$	Com'l, Ind'l	-1	+1	μA	
			Automotive	-10	+10	μA	
I_{OZ}	Output Leakage Current	$GND \leq V_{IN} \leq V_{CC}$, Output Disabled	Com'l, Ind'l	-1	+1	μA	
			Automotive	-10	+10	μA	
I_{CC}	V_{CC} Operating Supply Current	$V_{CC} = 3.6V$, $I_{OUT} = 0 \text{ mA}$, $f = f_{Max} = 1/t_{RC}$	All ranges	11	30	mA	
I_{SB1}	Automatic CE Power-down Current— TTL Inputs	$V_{CC} = 3.6V$, $\overline{CE} \geq V_{IH}$, $V_{IN} \geq V_{IH}$ or $V_{IN} \leq V_{IL}$, $f = f_{Max}$	All ranges	100	300	μA	
I_{SB2}	Automatic CE Power-down Current— CMOS Inputs	$V_{CC} = 3.6V$, $\overline{CE} \geq V_{CC} - 0.3V$, $V_{IN} \geq V_{CC} - 0.3V$ or $V_{IN} \leq 0.3V$, $f = 0$	Com'l	0.1	5	μA	
			Ind'l		0.1		10
			Automotive		0.1		130

Notes:

- V_{IL} (min.) = -2.0V for pulse durations of less than 20 ns.
- T_A is the "Instant-On" case temperature.

Capacitance^[5]

Parameter	Description	Test Conditions	Max.	Unit
C _{IN}	Input Capacitance	T _A = 25°C, f = 1 MHz, V _{CC} = V _{CC(typ.)}	6	pF
C _{OUT}	Output Capacitance		8	pF

Thermal Resistance

Parameter	Description	Test Conditions	SOIC	TSOPI	RTSOPI	Unit
θ _{JA}	Thermal Resistance (Junction to Ambient) ^[6]	Still Air, soldered on a 3 × 4.5 inch, 2-layer printed circuit board	68.45	87.62	87.62	°C/W
θ _{JC}	Thermal Resistance (Junction to Case) ^[5]		26.94	23.73	23.73	°C/W

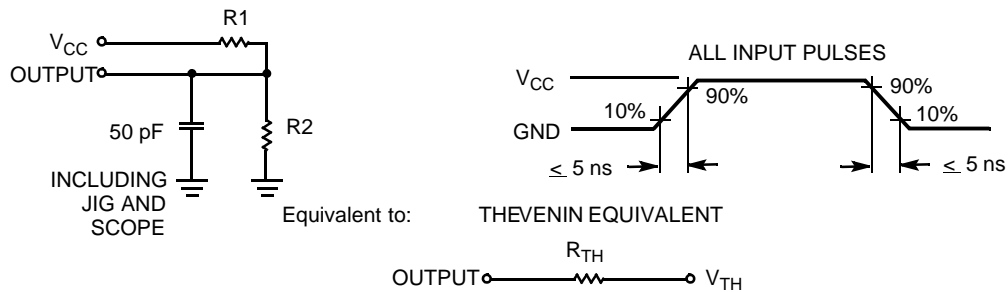
AC Test Loads and Waveforms

Parameter	3.3V	Units
R1	1100	Ohms
R2	1500	Ohms
R _{TH}	645	Ohms
V _{TH}	1.750	Volts

Data Retention Characteristics (Over the Operating Range)

Parameter	Description	Conditions ^[6]	Min.	Typ. ^[2]	Max.	Unit
V _{DR}	V _{CC} for Data Retention		1.4			V
I _{CCDR}	Data Retention Current	V _{CC} = 1.4V, $\overline{CE} \geq V_{CC} - 0.3V$, V _{IN} ≥ V _{CC} - 0.3V or V _{IN} ≤ 0.3V	Com'l	0.1	3	μA
			Ind'l	0.1	6	
			Auto	0.1	50	
t _{CDR} ^[6]	Chip Deselect to Data Retention Time		0			ns
t _R ^[6]	Operation Recovery Time		t _{RC}			ns

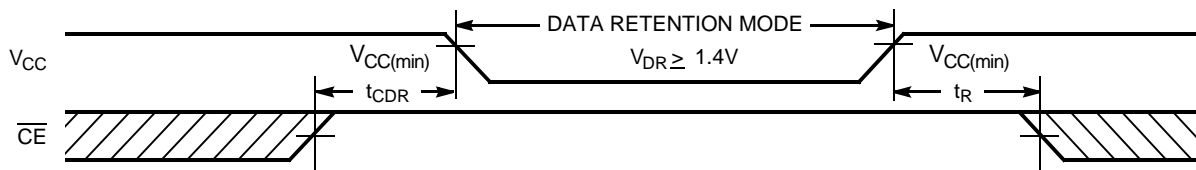
Data Retention Waveform

Notes:

- Tested initially and after any design or process changes that may affect these parameters.
- No input may exceed V_{CC} + 0.3V.

Switching Characteristics Over the Operating Range^[7]

Parameter	Description	CY62256V-70		Unit
		Min.	Max.	
Read Cycle				
t_{RC}	Read Cycle Time	70		ns
t_{AA}	Address to Data Valid		70	ns
t_{OHA}	Data Hold from Address Change	10		ns
t_{ACE}	\overline{CE} LOW to Data Valid		70	ns
t_{DOE}	\overline{OE} LOW to Data Valid		35	ns
t_{LZOE}	\overline{OE} LOW to Low-Z ^[8]	5		ns
t_{HZOE}	\overline{OE} HIGH to High-Z ^[8, 9]		25	ns
t_{LZCE}	\overline{CE} LOW to Low-Z ^[8]	10		ns
t_{HZCE}	\overline{CE} HIGH to High-Z ^[8, 9]		25	ns
t_{PU}	\overline{CE} LOW to Power-up	0		ns
t_{PD}	\overline{CE} HIGH to Power-down		70	ns
Write Cycle^[10, 11]				
t_{WC}	Write Cycle Time	70		ns
t_{SCE}	\overline{CE} LOW to Write End	60		ns
t_{AW}	Address Set-up to Write End	60		ns
t_{HA}	Address Hold from Write End	0		ns
t_{SA}	Address Set-up to Write Start	0		ns
t_{PWE}	\overline{WE} Pulse Width	50		ns
t_{SD}	Data Set-up to Write End	30		ns
t_{HD}	Data Hold from Write End	0		ns
t_{HZWE}	\overline{WE} LOW to High-Z ^[8, 9]		25	ns
t_{LZWE}	\overline{WE} HIGH to Low-Z ^[8]	10		ns

Notes:

7. Test conditions assume signal transition time of 5 ns or less timing reference levels of $V_{CC}/2$, input pulse levels of 0 to V_{CC} , and output loading of the specified I_{OL}/I_{OH} and 50 pF load capacitance.
8. At any given temperature and voltage condition, t_{HZCE} is less than t_{LZCE} , t_{HZOE} is less than t_{LZOE} , and t_{HZWE} is less than t_{LZWE} for any given device.
9. t_{HZOE} , t_{HZCE} , and t_{HZWE} are specified with $C_L = 5$ pF as in (b) of AC Test Loads. Transition is measured ± 200 mV from steady-state voltage.
10. The internal write time of the memory is defined by the overlap of \overline{CE} LOW and \overline{WE} LOW. Both signals must be LOW to initiate a write and either signal can terminate a write by going HIGH. The data input set-up and hold timing should be referenced to the rising edge of the signal that terminates the write.
11. The minimum write cycle time for write cycle #3 (\overline{WE} controlled, \overline{OE} LOW) is the sum of t_{HZWE} and t_{SD} .

Switching Waveforms

Read Cycle No. 1 (Address Transition Controlled)^[12, 13]

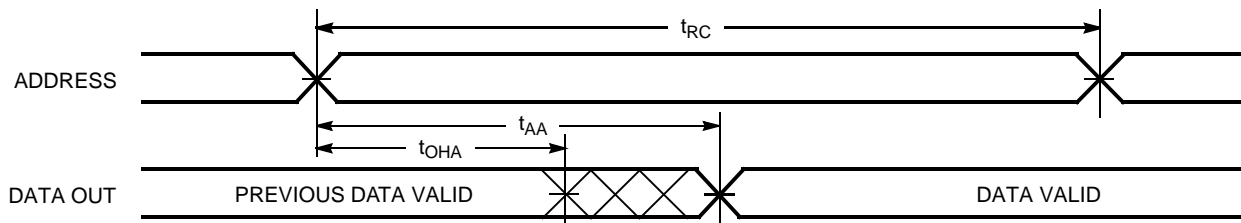

Read Cycle No. 2 (\overline{OE} Controlled)^[13, 14]

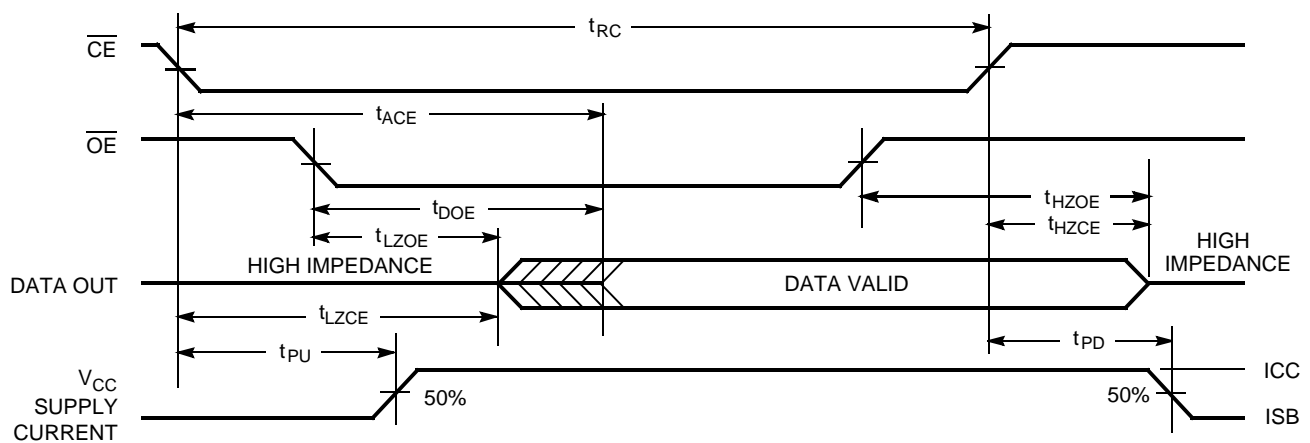

Write Cycle No. 1 (\overline{WE} Controlled)^[10, 15, 16]

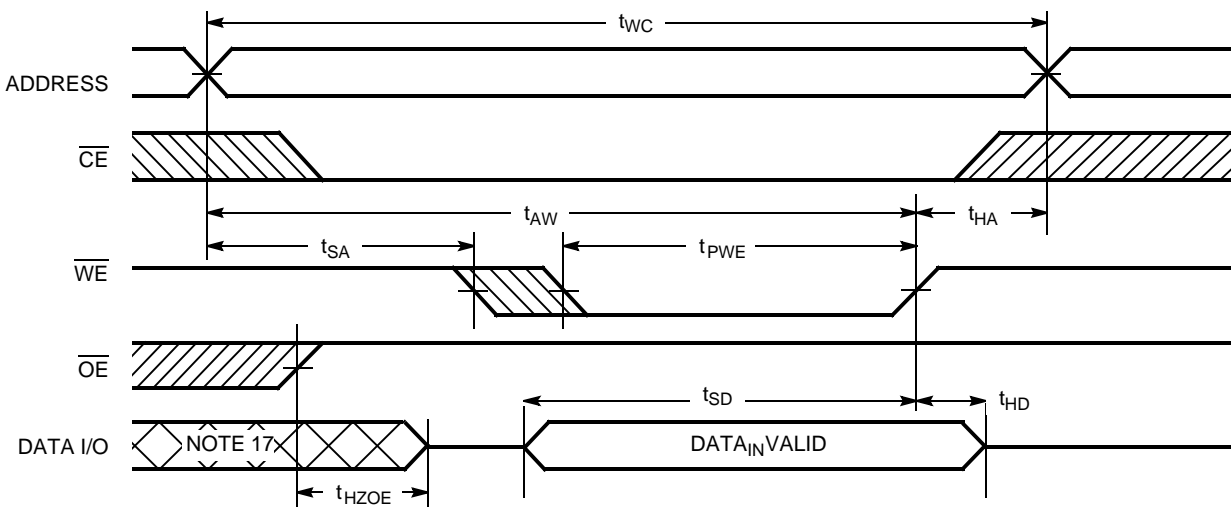

Notes:

- 12. Device is continuously selected. \overline{OE} , $\overline{CE} = V_{IL}$.
- 13. \overline{WE} is HIGH for read cycle.
- 14. Address valid prior to or coincident with \overline{CE} transition LOW.
- 15. Data I/O is high impedance if $\overline{OE} = V_{IH}$.
- 16. If \overline{CE} goes HIGH simultaneously with \overline{WE} HIGH, the output remains in a high-impedance state.
- 17. During this period, the I/Os are in output state and input signals should not be applied.

Switching Waveforms (continued)

Write Cycle No. 2 ($\overline{\text{CE}}$ Controlled)^[10, 15, 16]

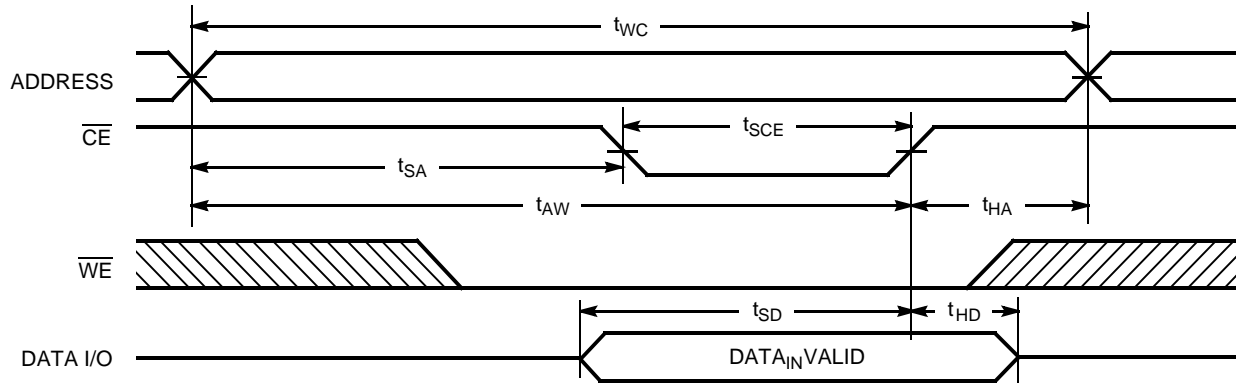

Write Cycle No. 3 ($\overline{\text{WE}}$ Controlled, $\overline{\text{OE}}$ LOW)^[11, 16]

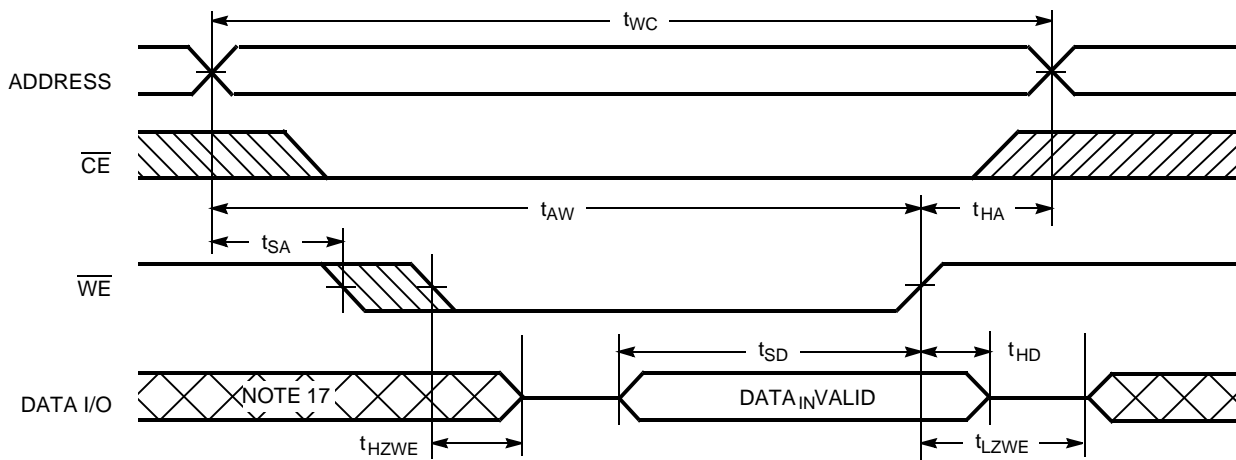

Typical DC and AC Characteristics

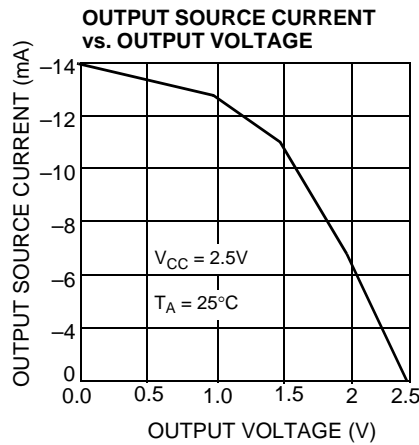
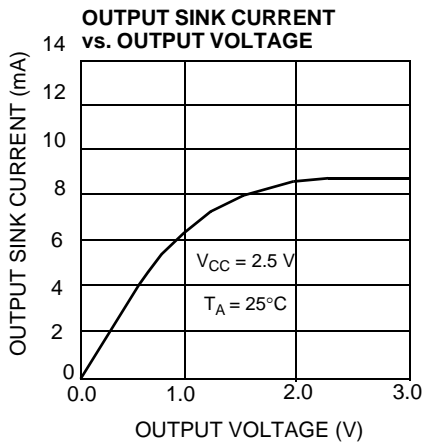
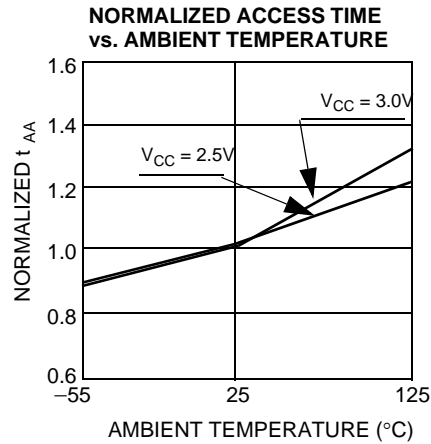
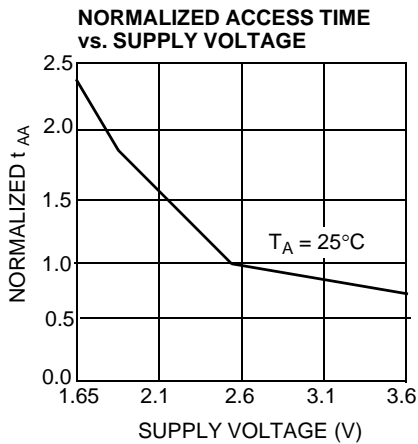
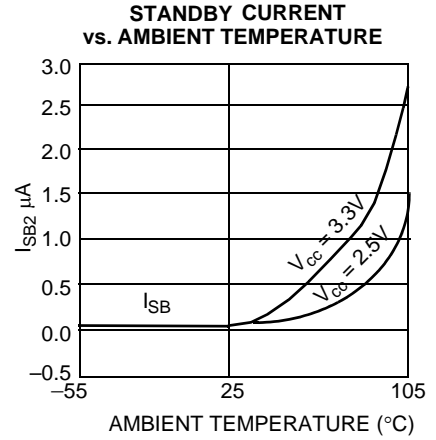
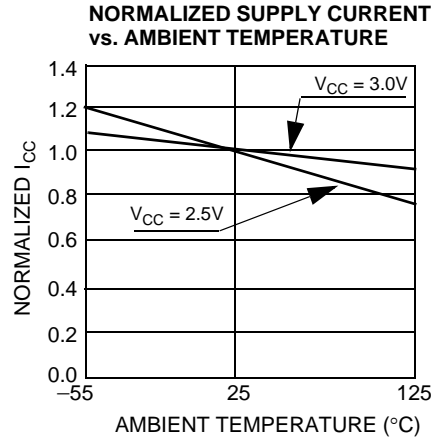
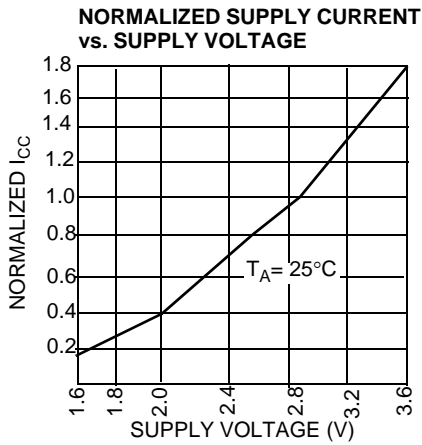

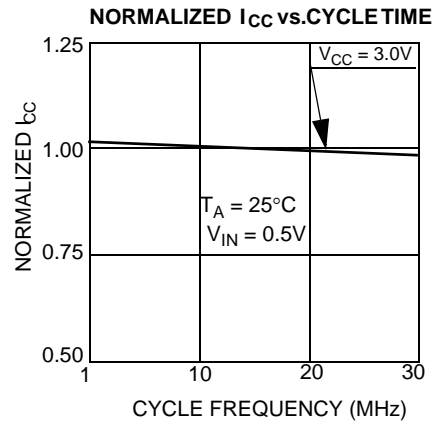
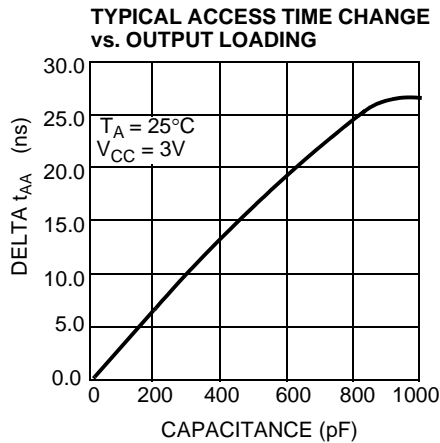
Typical DC and AC Characteristics (continued)

Truth Table

$\overline{\text{CE}}$	$\overline{\text{WE}}$	$\overline{\text{OE}}$	Inputs/Outputs	Mode	Power
H	X	X	High-Z	Deselect/Power-down	Standby (I_{SB})
L	H	L	Data Out	Read	Active (I_{CC})
L	L	X	Data In	Write	Active (I_{CC})
L	H	H	High-Z	Deselect, Output Disabled	Active (I_{CC})

Ordering Information

Speed (ns)	Ordering Code	Package Diagram	Package Type	Operating Range
70	CY62256VLL-70SNC	51-85092	28-pin (300-mil Narrow Body) SNC	Commercial
	CY62256VLL-70SNXC		28-pin (300-mil Narrow Body) SNC (Pb-Free)	
	CY62256VLL-70ZC	51-85071	28-pin TSOP I	
	CY62256VLL-70ZXC		28-pin TSOP I (Pb-Free)	
	CY62256VLL-70SNXI	51-85092	28-pin (300-mil Narrow Body) SNC (Pb-Free)	Industrial
	CY62256VLL-70ZI	51-85071	28-pin TSOP I	
	CY62256VLL-70ZXI		28-pin TSOP I (Pb-Free)	
	CY62256VLL-70ZRI	51-85074	28-pin Reverse TSOP I	
	CY62256VLL-70ZRXI		28-pin Reverse TSOP I (Pb-Free)	
	CY62256VLL-70SNE	51-85092	28-pin (300-mil Narrow Body) SNC	Automotive
	CY62256VLL-70SNXE		28-pin (300-mil Narrow Body) SNC (Pb-Free)	
	CY62256VLL-70ZE	51-85071	28-pin TSOP I	
	CY62256VLL-70ZXE		28-pin TSOP I (Pb-Free)	
	CY62256VLL-70ZRE	51-85074	28-pin Reverse TSOP I	
	CY62256VLL-70ZRXE		28-pin Reverse TSOP I (Pb-Free)	

Please contact your local Cypress sales representative for availability of these parts

Package Diagrams

28-pin (300-mil) SNC (Narrow Body) (51-85092)

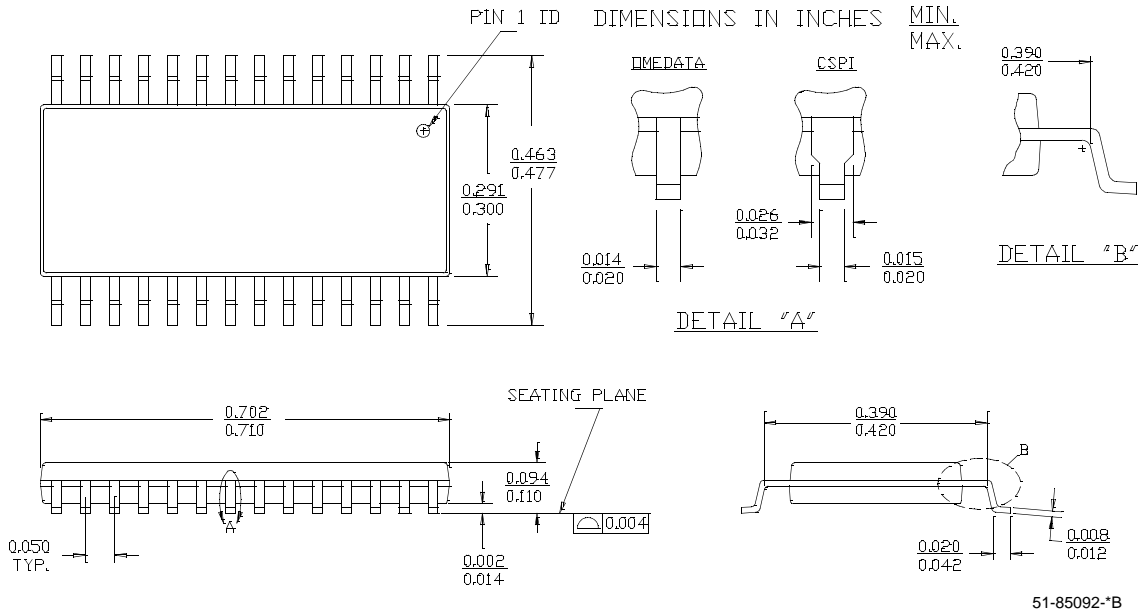

28-pin Thin Small Outline Package Type 1 (8 x 13.4 mm) (51-85071)

NOTE: ORIENTATION I.D. MAY BE LOCATED EITHER AS SHOWN IN OPTION 1 OR OPTION 2

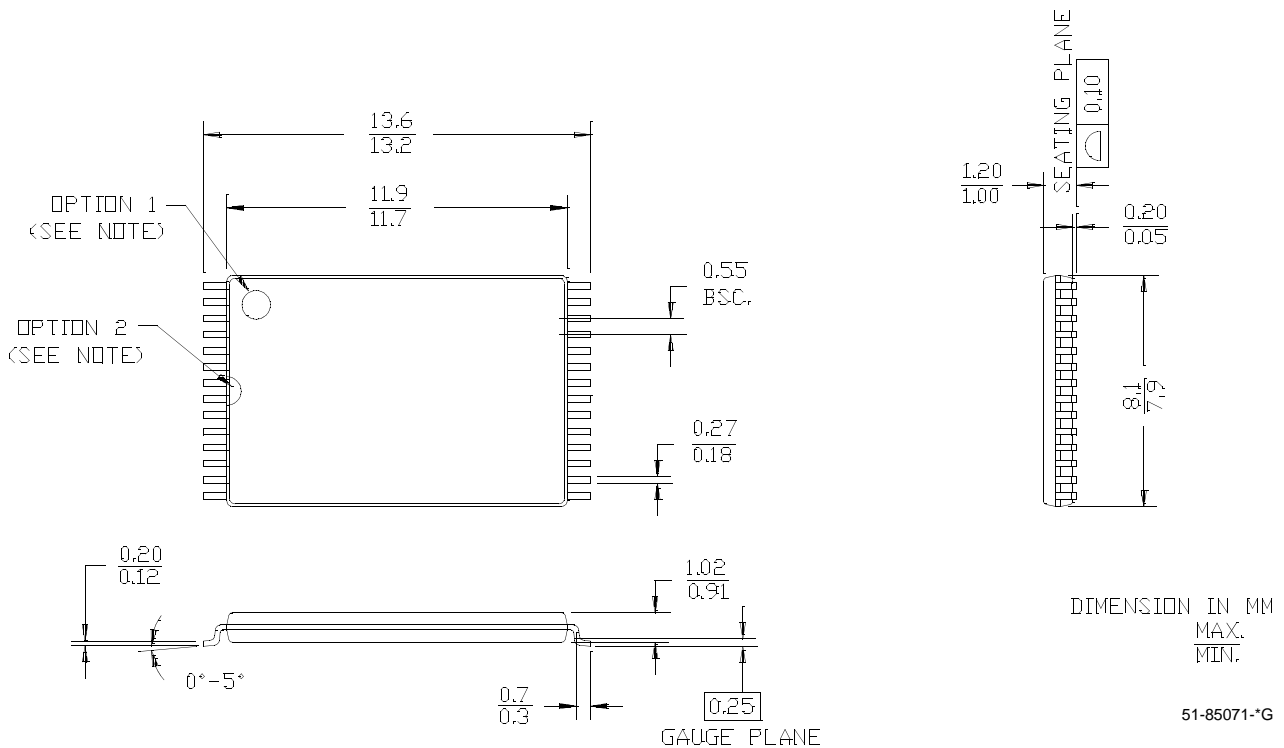

Package Diagrams (continued)

28-pin Reverse Thin Small Outline Package Type 1 (8 × 13.4 mm) (51-85074)

NOTE: ORIENTATION I.D. MAY BE LOCATED EITHER AS SHOWN IN OPTION 1 OR OPTION 2

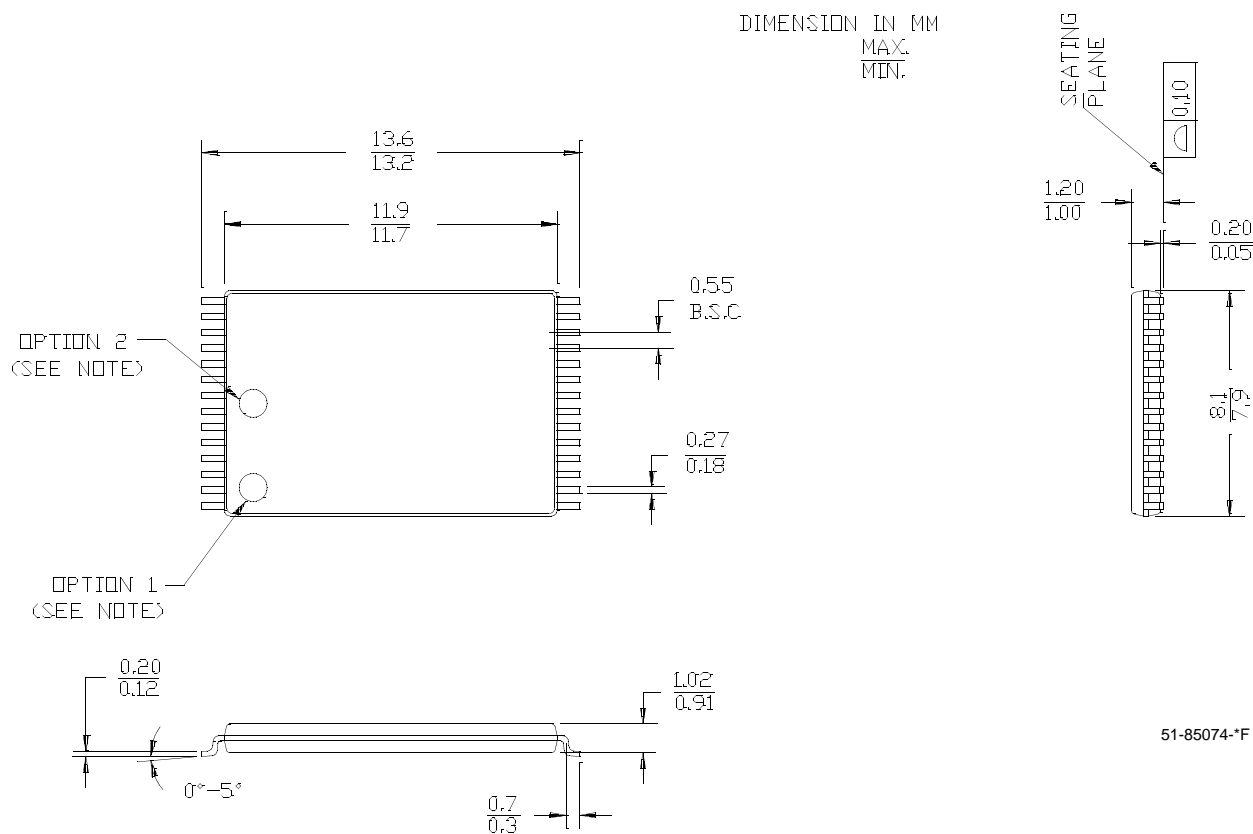

All product and company names mentioned in this document are the trademarks of their respective holders.

Document History Page

Document Title: CY62256V, 256K (32K x 8) Static RAM Document Number: 38-05057				
REV.	ECN NO.	Issue Date	Orig. of Change	Description of Change
**	107248	09/10/01	SZV	Changed from spec number: 38-00519 to 38-05057
*A	111445	11/01/01	MGN	Removed obsolete parts. Change to standard format
*B	115229	05/23/02	GBI	Changed SN package diagram
*C	116507	09/04/02	GBI	Added footnote 1 Clarified I _{CC} spec for V _{CC(typ)} = 2.5V
*D	239134	See ECN	AJU	Added Automotive product information
*E	344595	See ECN	SYT	Added Pb-Free packages on page# 10
*F	493277	See ECN	VKN	Changed address of Cypress Semiconductor Corporation on Page# 1 from "3901 North First Street" to "198 Champion Court" Removed part # CY62256V25LL from the product offering Updated Ordering Information Table