

128K x 8 Static RAM

Features

- 4.5V – 5.5V operation
- CMOS for optimum speed/power
- Low active power (70 ns, LL version)
 - 330 mW (max.) (60 mA)
- Low standby power (70 ns, LL version)
 - 110 μ W (max.) (20 μ A)
- Automatic power-down when deselected
- TTL-compatible inputs and outputs
- Easy memory expansion with \overline{CE}_1 , CE_2 , and \overline{OE} options

Functional Description

The CY62128 is a high-performance CMOS static RAM organized as 131,072 words by 8 bits. Easy memory expansion is provided by an active LOW chip enable (\overline{CE}_1), an active HIGH chip enable (CE_2), an active LOW output enable (\overline{OE}), and three-state drivers. This device has an automatic power-down

feature that reduces power consumption by more than 75% when deselected.

Writing to the device is accomplished by taking chip enable one (\overline{CE}_1) and write enable (\overline{WE}) inputs LOW and chip enable two (CE_2) input HIGH. Data on the eight I/O pins (I/O_0 through I/O_7) is then written into the location specified on the address pins (A_0 through A_{16}).

Reading from the device is accomplished by taking chip enable one (\overline{CE}_1) and output enable (\overline{OE}) LOW while forcing write enable (\overline{WE}) and chip enable two (CE_2) HIGH. Under these conditions, the contents of the memory location specified by the address pins will appear on the I/O pins.

The eight input/output pins (I/O_0 through I/O_7) are placed in a high-impedance state when the device is deselected (\overline{CE}_1 HIGH or CE_2 LOW), the outputs are disabled (\overline{OE} HIGH), or during a write operation (\overline{CE}_1 LOW, CE_2 HIGH, and \overline{WE} LOW).

The CY62128 is available in a standard 400-mil-wide SOJ, 525-mil wide (450-mil-wide body width) SOIC and 32-pin TSOP type I.

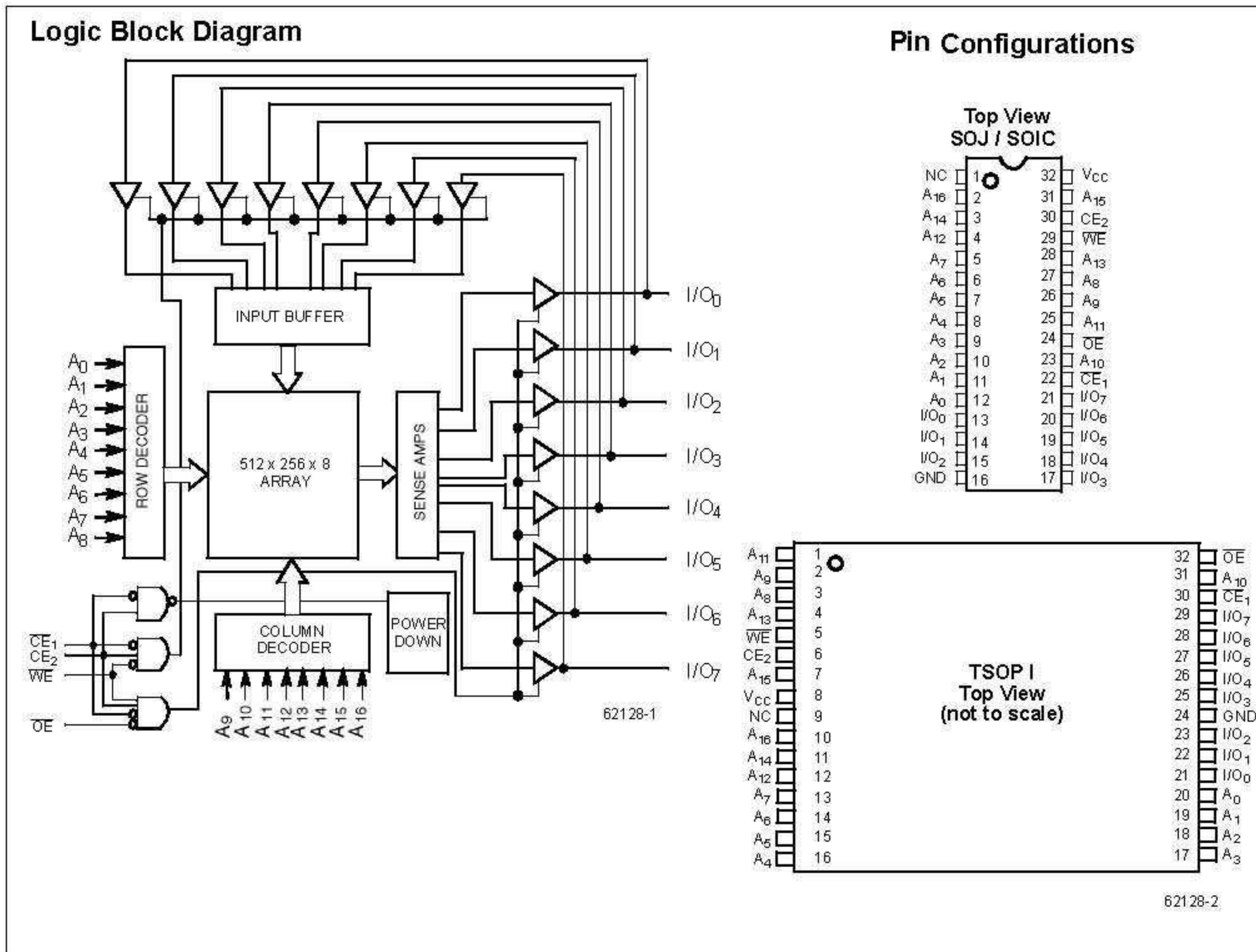

Selection Guide

		CY62128-55	CY62128-70
Maximum Access Time (ns)		55	70
Maximum Operating Current	Commercial	115 mA	110 mA
	L	70 mA	60 mA
	LL	70 mA	60 mA
Maximum CMOS Standby Current	Commercial	10 mA	10 mA
	L	100 μ A	100 μ A
	LL	20 μ A	20 μ A

Maximum Ratings

(Above which the useful life may be impaired. For user guidelines, not tested.)

Storage Temperature -65°C to +150°C

Ambient Temperature with Power Applied -55°C to +125°C

Supply Voltage on V_{CC} to Relative GND^[1] -0.5V to +7.0V

DC Voltage Applied to Outputs in High Z State^[1] -0.5V to $V_{CC} + 0.5V$

DC Input Voltage^[1] -0.5V to $V_{CC} + 0.5V$

Current into Outputs (LOW) 20 mA

Static Discharge Voltage >2001V (per MIL-STD-883, Method 3015)

Latch-Up Current >200 mA

Operating Range

Range	Ambient Temperature ^[2]	V_{CC}
Commercial	0°C to +70°C	5V \pm 10%

Electrical Characteristics Over the Operating Range^[3]

Parameter	Description	Test Conditions	62128-55		62128-70		Unit
			Min.	Max.	Min.	Max.	
V_{OH}	Output HIGH Voltage	$V_{CC} = \text{Min.}, I_{OH} = -1.0 \text{ mA}$	2.4		2.4		V
V_{OL}	Output LOW Voltage	$V_{CC} = \text{Min.}, I_{OL} = 2.1 \text{ mA}$		0.4		0.4	V
V_{IH}	Input HIGH Voltage		2.2	$V_{CC} + 0.3$	2.2	$V_{CC} + 0.3$	V
V_{IL}	Input LOW Voltage ^[1]		-0.3	0.8	-0.3	0.8	V
I_{IX}	Input Load Current	$GND \leq V_I \leq V_{CC}$	-1	+1	-1	+1	μ A
I_{OZ}	Output Leakage Current	$GND \leq V_I \leq V_{CC}$, Output Disabled	-5	+5	-5	+5	μ A
I_{OS}	Output Short Circuit Current ^[4]	$V_{CC} = \text{Max.}, V_{OUT} = GND$		-300		-300	mA
I_{CC}	V_{CC} Operating Supply Current	$V_{CC} = \text{Max.}, I_{OUT} = 0 \text{ mA}, f = f_{MAX} = 1/t_{RC}$	Com'l	115		110	mA
			L	70		60	mA
			LL	70		60	mA
I_{SB1}	Automatic CE Power-Down Current —TTL Inputs	Max. V_{CC} , $CE_1 \geq V_{IH}$ or $CE_2 \leq V_{IL}$, $V_{IN} \geq V_{IH}$ or $V_{IN} \leq V_{IL}$, $f = f_{MAX}$	Com'l	25		25	mA
			L	10		10	mA
			LL	2		2	mA
I_{SB2}	Automatic CE Power-Down Current —CMOS Inputs	Max. V_{CC} , $CE_1 \geq V_{CC} - 0.3V$, or $CE_2 \leq 0.3V$, $V_{IN} \geq V_{CC} - 0.3V$, or $V_{IN} \leq 0.3V$, $f=0$	Com'l	10		10	mA
			L	100		100	μ A
			LL	20		20	μ A

Shaded areas contain advance information

Notes:

- V_{IL} (min.) = -2.0V for pulse durations of less than 20 ns.
- T_A is the "instant on" case temperature.
- See the last page of this specification for Group A subgroup testing information.
- Not more than one output should be shorted at one time. Duration of the short circuit should not exceed 30 seconds.

Capacitance^[5]

Parameter	Description	Test Conditions	Max.	Unit
C_{IN}	Input Capacitance	$T_A = 25^\circ\text{C}, f = 1\text{ MHz},$ $V_{CC} = 5.0\text{V}$	9	pF
C_{OUT}	Output Capacitance		9	pF

AC Test Loads and Waveforms

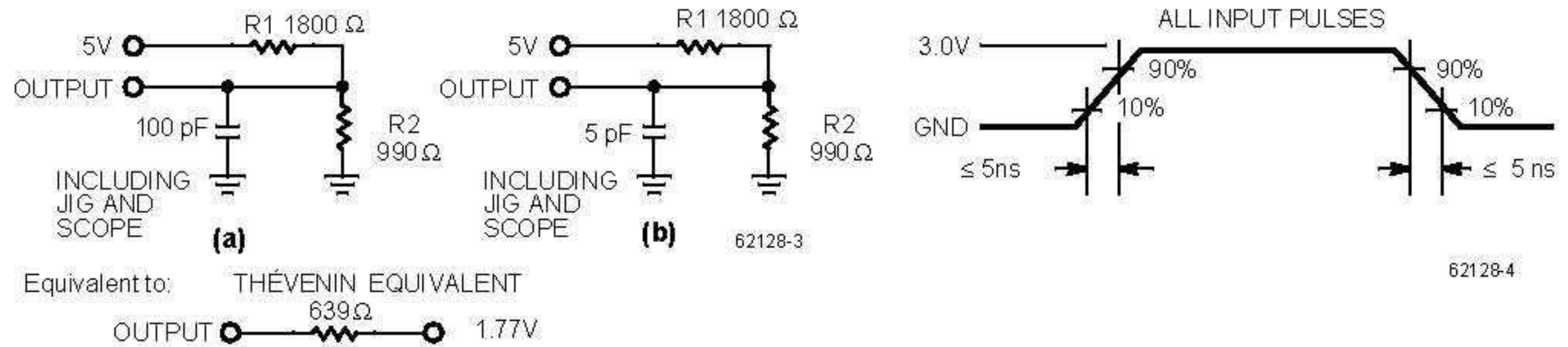

Switching Characteristics^[3,6] Over the Operating Range

Parameter	Description	62128-55		62128-70		Unit
		Min.	Max.	Min.	Max.	
READ CYCLE						
t_{RC}	Read Cycle Time	55		70		ns
t_{AA}	Address to Data Valid		55		70	ns
t_{OHA}	Data Hold from Address Change	5		5		ns
t_{ACE}	\overline{CE}_1 LOW to Data Valid, CE_2 HIGH to Data Valid		55		70	ns
t_{DOE}	\overline{OE} LOW to Data Valid		20		35	ns
t_{LZOE}	\overline{OE} LOW to Low Z	0		0		ns
t_{HZOE}	\overline{OE} HIGH to High Z ^[7, 8]		20		25	ns
t_{LZCE}	\overline{CE}_1 LOW to Low Z, CE_2 HIGH to Low Z ^[8]	5		5		ns
t_{HZCE}	\overline{CE}_1 HIGH to High Z, CE_2 LOW to High Z ^[7, 8]		20		25	ns
t_{PU}	\overline{CE}_1 LOW to Power-Up, CE_2 HIGH to Power-Up	0		0		ns
t_{PD}	\overline{CE}_1 HIGH to Power-Down, CE_2 LOW to Power-Down		55		70	ns
WRITE CYCLE^[9]						
t_{WC}	Write Cycle Time	55		70		ns
t_{SCE}	\overline{CE}_1 LOW to Write End, CE_2 HIGH to Write End	45		60		ns
t_{AW}	Address Set-Up to Write End	45		60		ns
t_{HA}	Address Hold from Write End	0		0		ns
t_{SA}	Address Set-Up to Write Start	0		0		ns
t_{PWE}	\overline{WE} Pulse Width	45		50		ns
t_{SD}	Data Set-Up to Write End	45		55		ns

Shaded areas contain advance information

Notes:

- Tested initially and after any design or process changes that may affect these parameters.
- Test conditions assume signal transition time of 5ns or less, timing reference levels of 1.5V, input pulse levels of 0 to 3.0V, and output loading of the specified I_{OL}/I_{OH} and 100pF load capacitance.
- t_{HZOE} , t_{HZCE} , and t_{HZWE} are specified with a load capacitance of 5 pF as in part (b) of AC Test Loads. Transition is measured ± 500 mV from steady-state voltage.
- At any given temperature and voltage condition, t_{HZCE} is less than t_{LZCE} ; t_{HZOE} is less than t_{LZOE} , and t_{HZWE} is less than t_{LZWE} for any given device.
- The internal write time of the memory is defined by the overlap of \overline{CE}_1 LOW, CE_2 HIGH, and \overline{WE} LOW. \overline{CE}_1 and \overline{WE} must be LOW and CE_2 HIGH to initiate a write, and the transition of any of these signals can terminate the write. The input data set-up and hold timing should be referenced to the leading edge of the signal that terminates the write.

Switching Characteristics^[3,6] Over the Operating Range (continued)

Parameter	Description	62128-55		62128-70		Unit
		Min.	Max.	Min.	Max.	
t_{HD}	Data Hold from Write End	0		0		ns
t_{LZWE}	\overline{WE} HIGH to Low Z ^[8]	5		5		ns
t_{HZWE}	\overline{WE} LOW to High Z ^[7,8]		20		25	ns

Shaded area contains advanced information.

Switching Waveforms

Read Cycle No.1^[10,11]

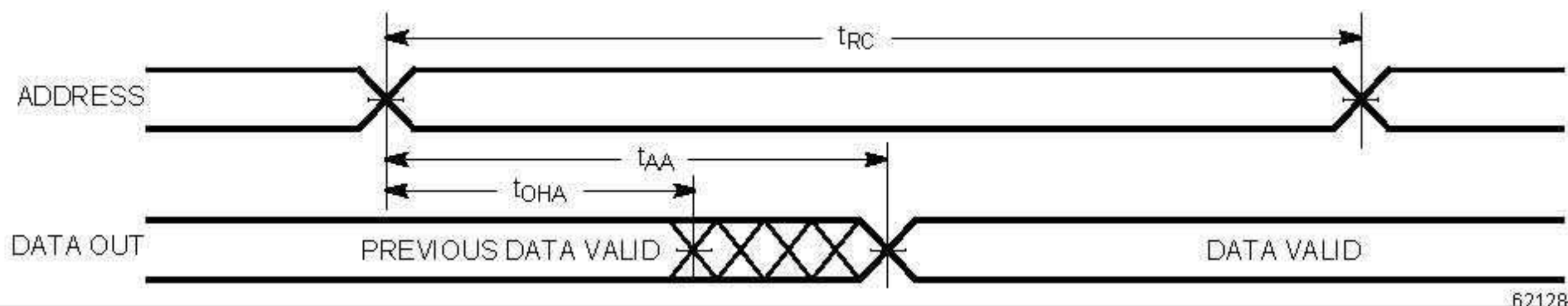

62128-5

Read Cycle No. 2 (\overline{OE} Controlled)^[11,12]

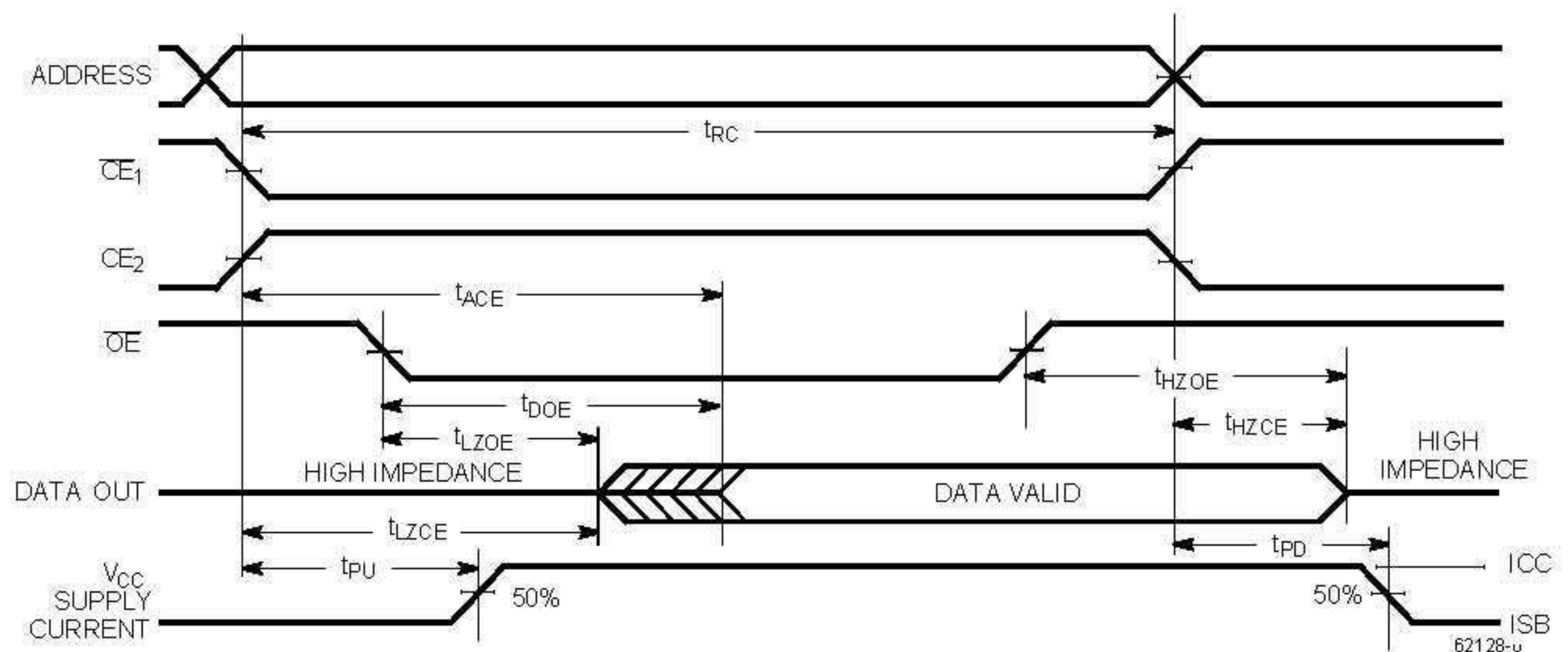

62128-u

Notes:

10. Device is continuously selected. $\overline{OE}, \overline{CE}_1 = V_{IL}, \overline{CE}_2 = V_{IH}$.
11. \overline{WE} is HIGH for read cycle.
12. Address valid prior to or coincident with \overline{CE}_1 transition LOW and \overline{CE}_2 transition HIGH.

Switching Waveforms (continued)

Write Cycle No. 1 (\overline{CE}_1 or CE_2 Controlled)^[13,14]

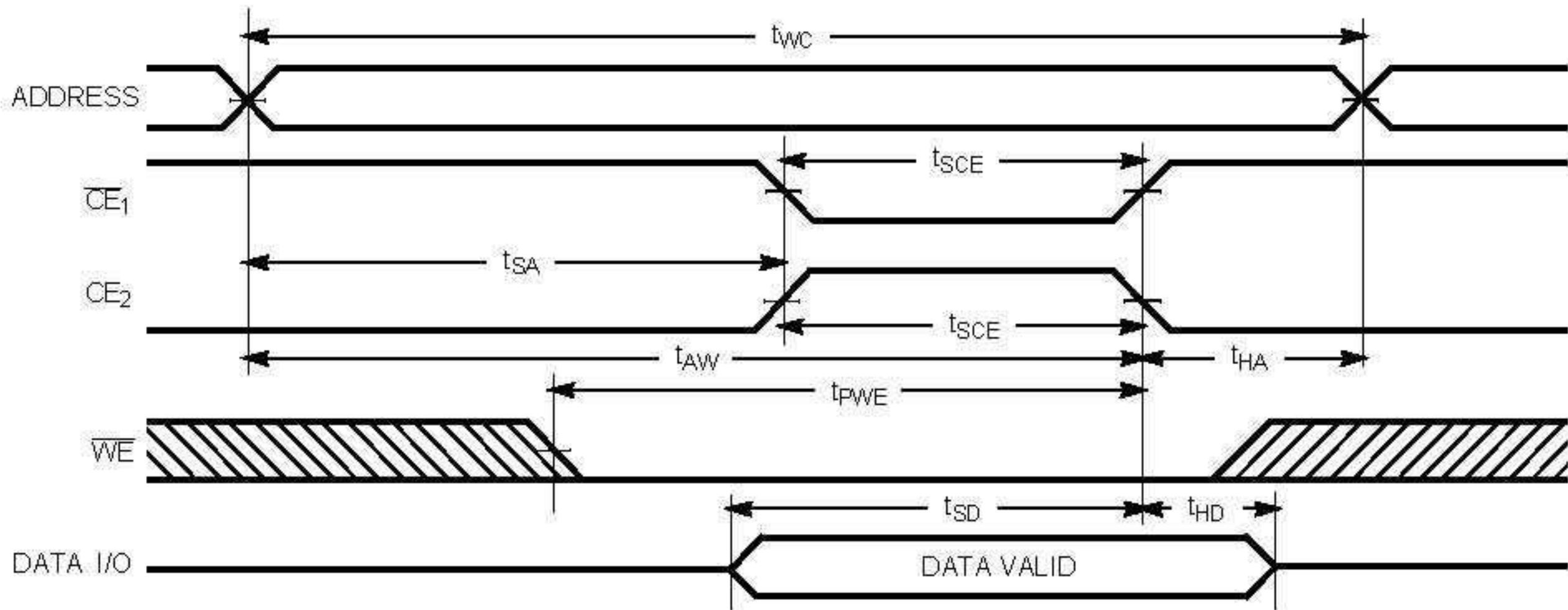

62128-7

Write Cycle No. 2 (\overline{WE} Controlled, \overline{OE} HIGH During Write)^[13,14]

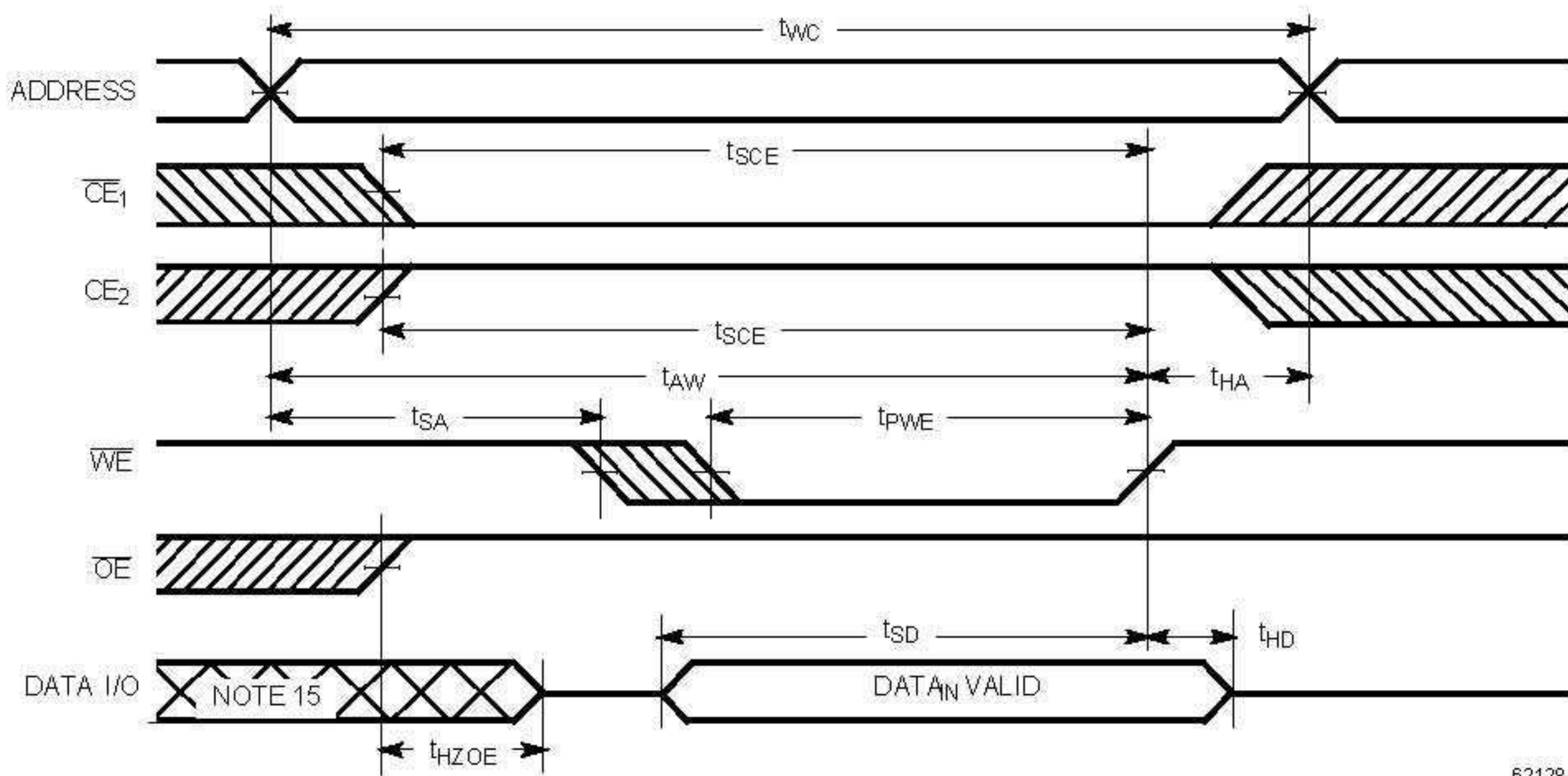

62128-8

Notes:

- 13. Data I/O is high impedance if $\overline{OE} = V_{IH}$.
- 14. If \overline{CE}_1 goes HIGH or CE_2 goes LOW simultaneously with \overline{WE} going HIGH, the output remains in a high-impedance state.
- 15. During this period the I/Os are in the output state and input signals should not be applied.

Switching Waveforms (continued)

Write Cycle No.3 (\overline{WE} Controlled, \overline{OE} LOW)^[13,14]

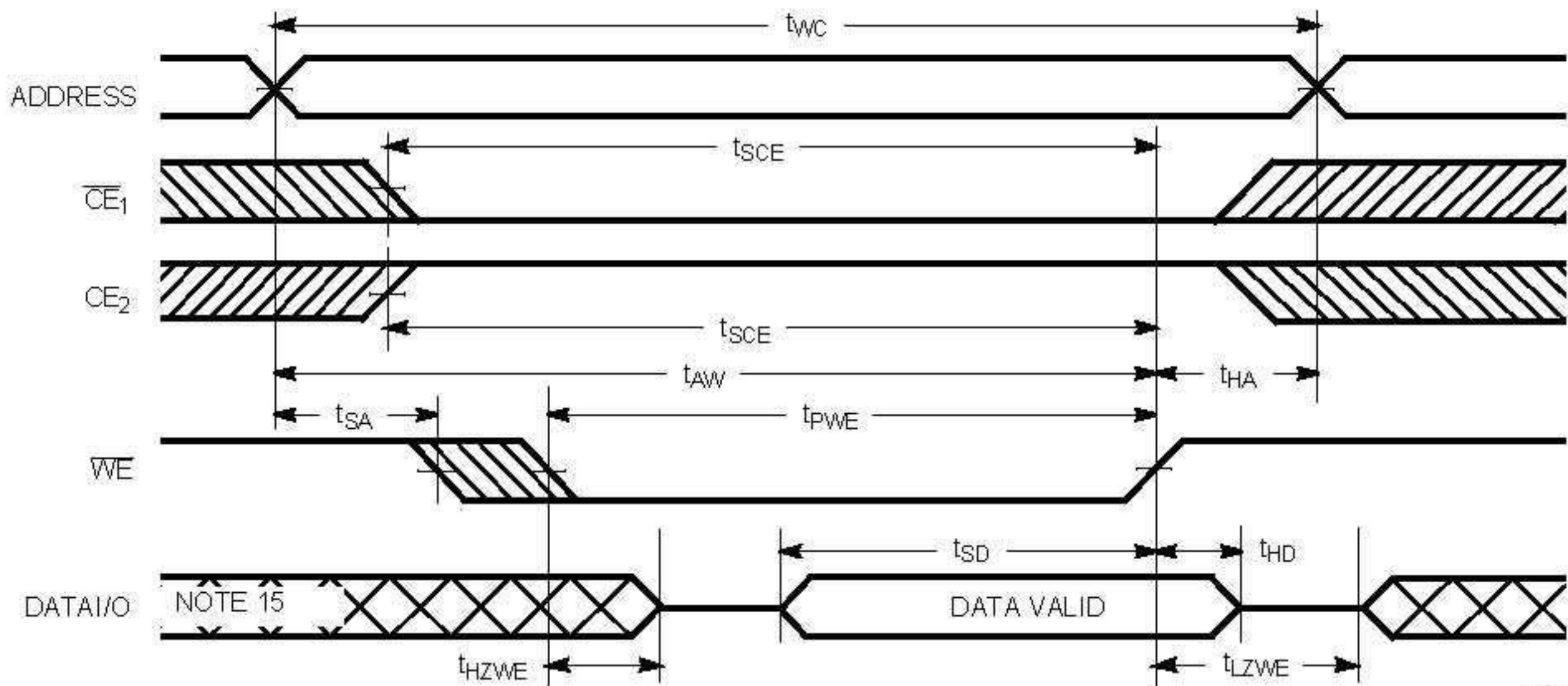

62128-9

Truth Table

CE ₁	CE ₂	OE	WE	I/O ₀ - I/O ₇	Mode	Power
H	X	X	X	High Z	Power-Down	Standby (I _{SB})
X	L	X	X	High Z	Power-Down	Standby (I _{SB})
L	H	L	H	Data Out	Read	Active (I _{CC})
L	H	X	L	Data In	Write	Active (I _{CC})
L	H	H	H	High Z	Selected, Outputs Disabled	Active (I _{CC})

Ordering Information

Speed (ns)	Ordering Code	Package Name	Package Type	Operating Range
55	CY62128-55VC	V33	32-Lead (400-Mil) Molded SOJ	Commercial
	CY62128-55SC	S34	32-Lead (450-Mil) Molded SOIC	
	CY62128-55ZC	Z32	32-Lead TSOP Type I	
70	CY62128-70VC	V33	32-Lead (400-Mil) Molded SOJ	Commercial
	CY62128-70SC	S34	32-Lead (450-Mil) Molded SOIC	
	CY62128-70ZC	Z32	32-Lead TSOP Type I	
	CY62128L-70SC	S34	32-Lead (450-Mil) Molded SOIC	
	CY62128L-70ZC	Z32	32-Lead TSOP Type I	
	CY62128LL-70SC	S34	32-Lead (450-Mil) Molded SOIC	
	CY62128LL-70ZC	Z32	32-Lead TSOP Type I	

Shaded area contains advanced information.

Document #: 38-00524

Package Diagrams

32-Lead (450 Mil) Molded SOIC S34

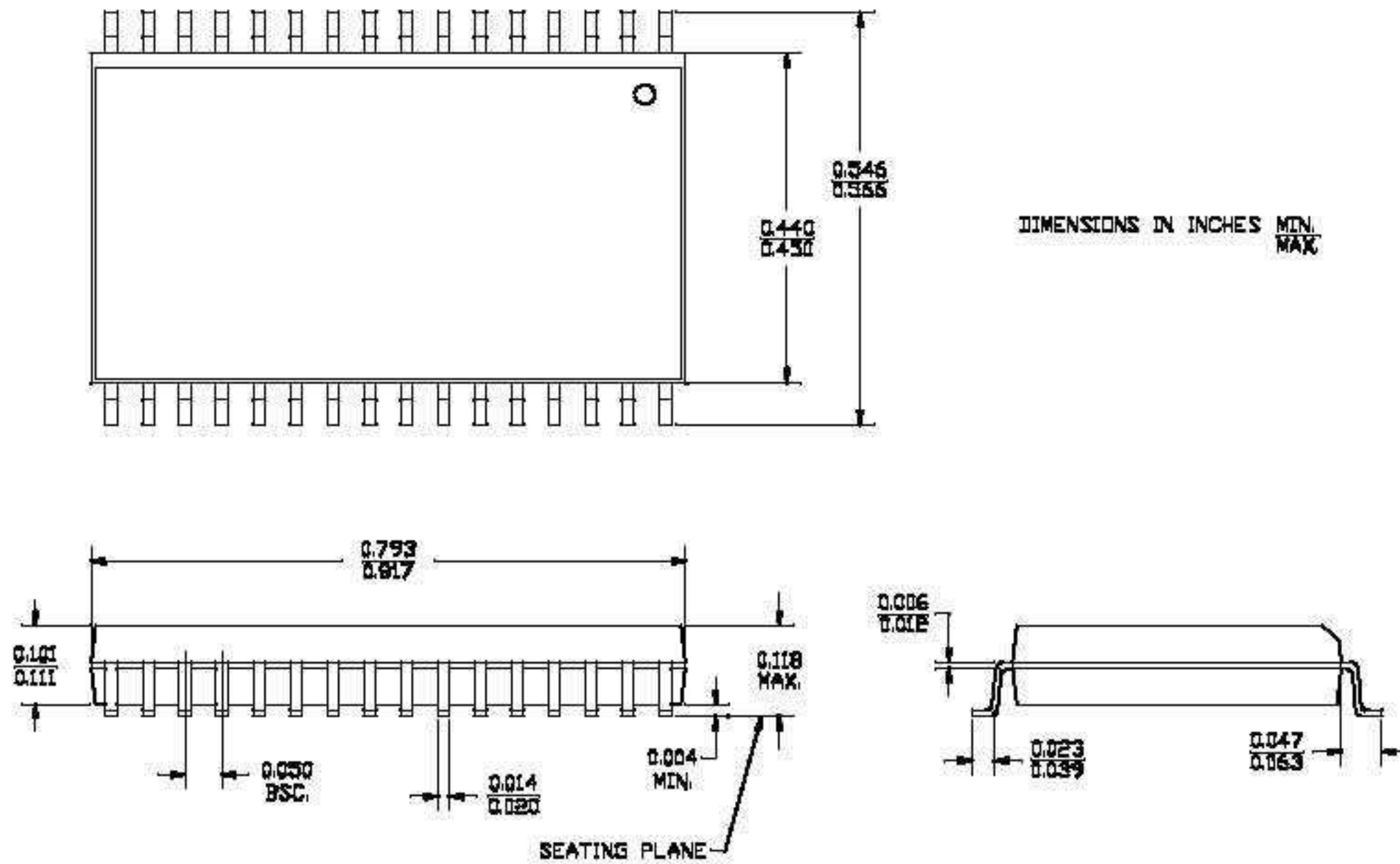

32-Lead Thin Small Outline Package Z32

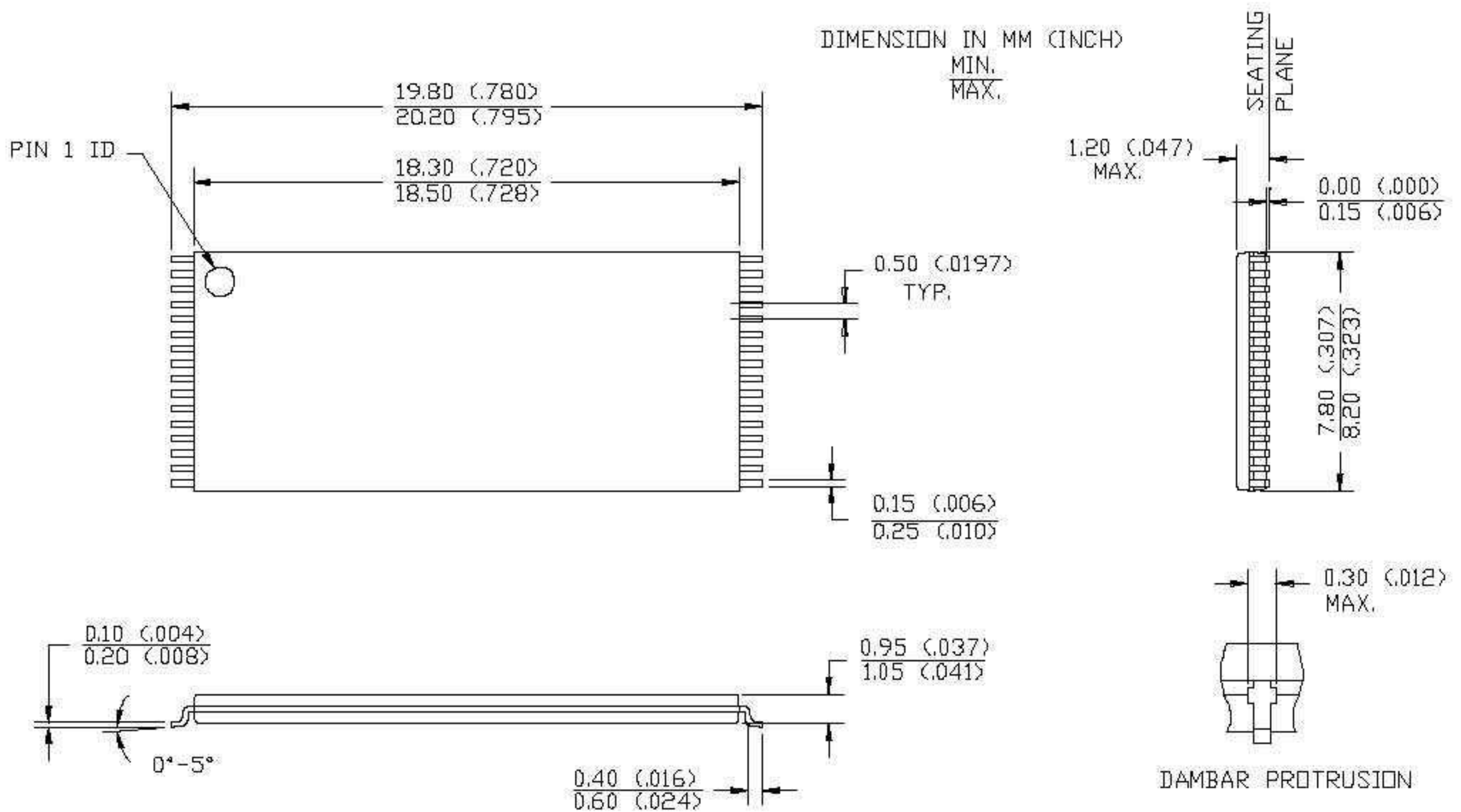

Package Diagrams (continued)

32-Lead (400-Mil) Molded SOJ V33

DIMENSIONS IN INCHES MIN.
MAX.

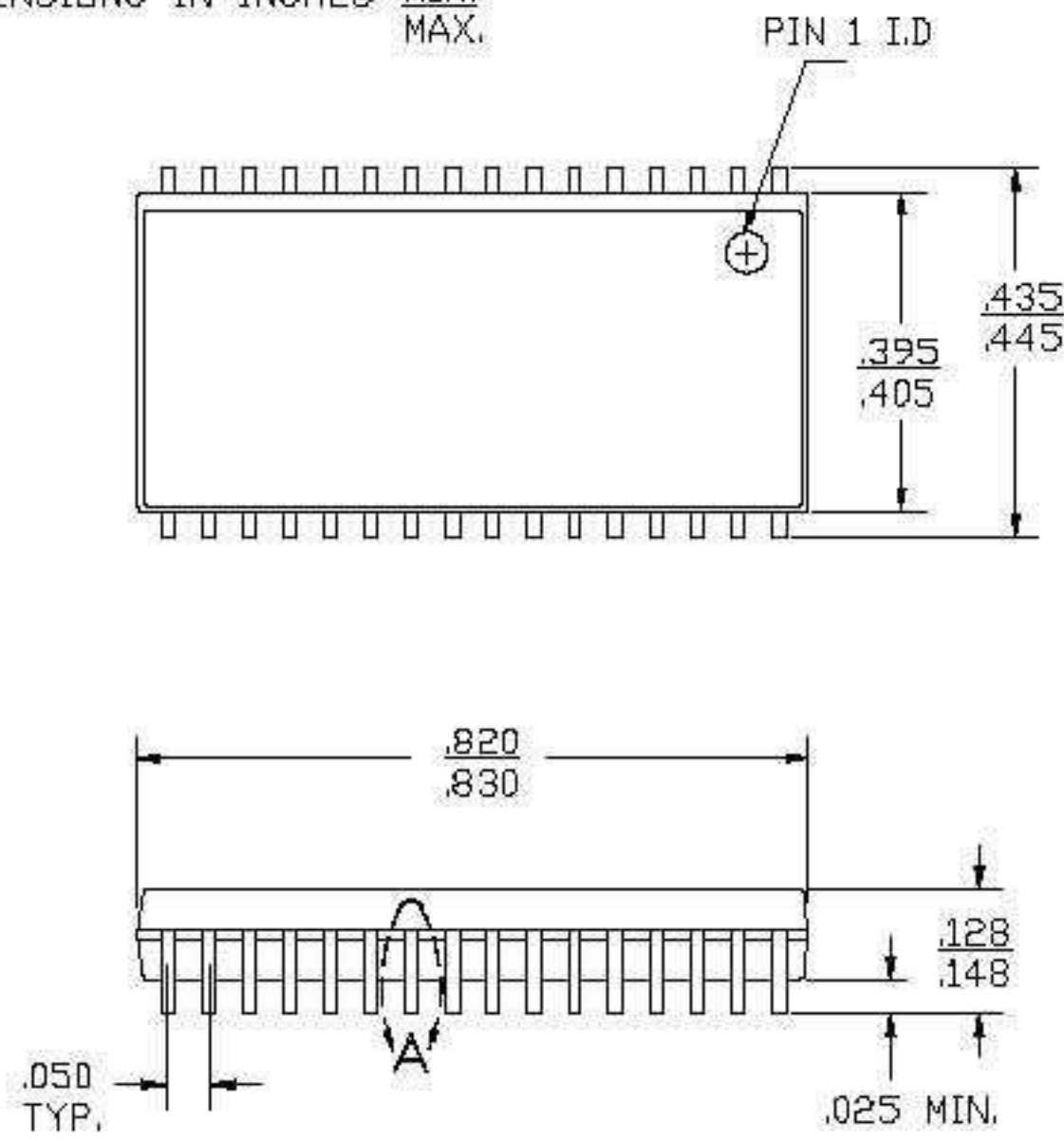

DETAIL A
EXTERNAL LEAD DESIGN

