

# Phase-Aligned Clock Multiplier

## Features

- 4-multiplier configuration
- Single PLL architecture
- Phase alignment
- Low jitter, high accuracy outputs
- Output enable pin
- 3.3 V operation
- 5 V tolerant input
- Internal loop filter
- 8-pin 150-mil small-outline integrated circuit (SOIC) package
- Commercial temperature

## Functional Description

The CY2300 is a 4 output 3.3 V phase-aligned system clock designed to distribute high-speed clocks in PC, workstation, datacom, telecom, and other high-performance applications.

The part allows the user to obtain  $1/2x$ ,  $1x$ ,  $\overline{1x}$  and  $2x$  REF<sub>IN</sub> output frequencies on respective output pins.

The part has an on-chip PLL which locks to an input clock presented on the REF<sub>IN</sub> pin. The input-to-output skew is guaranteed to be less than  $\pm 200$  ps, and output-to-output skew is guaranteed to be less than 200 ps.

Multiple CY2300 devices can accept the same input clock and distribute it in a system. In this case, the skew between the outputs of two devices is guaranteed to be less than 400 ps.

The CY2300 is available in commercial temperature range.

## Logic Block Diagram

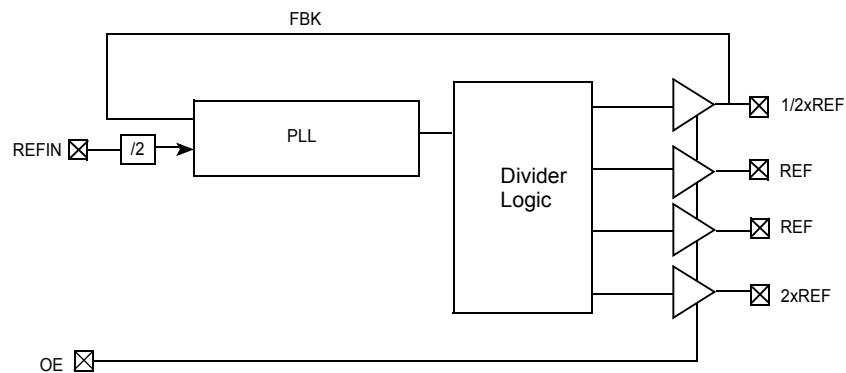

Pinouts

Figure 1. CY2300 – 8-pin SOIC - Top View

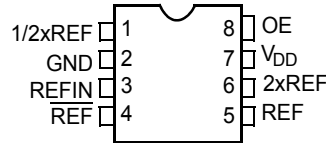

Table 1. Pin Definitions

Pin	Signal <sup>[1]</sup>	Description
1	1/2xREF	Clock output, 1/2x reference
2	GND	Ground
3	REFIN	Input reference frequency, 5 V tolerant input
4	REF	Clock output reference
5	REF	Clock output reference
6	2xREF	Clock output, 2x reference
7	V <sub>DD</sub>	3.3 V Supply
8	OE	Output enable (weak pull-up)

Maximum Ratings

Supply voltage to ground potential .....–0.5 V to +7.0 V  
 DC input voltage (except ref) .....–0.5 V to V<sub>DD</sub> + 0.5 V  
 DC input voltage REF .....–0.5 V to 7 V  
 Storage temperature ..... –65 °C to +150 °C

Junction temperature ..... 150 °C  
 Static discharge voltage  
 (per MIL-STD-883, method 3015) ..... > 2000 V

Operating Conditions

Parameter	Description	Min	Max	Unit
V <sub>DD</sub>	Supply voltage	3.0	3.6	V
T <sub>A</sub>	Operating temperature (ambient temperature)	0	70	°C
C <sub>L</sub>	Load capacitance, 10 MHz < F <sub>OUT</sub> < 133.33 MHz	–	18	pF
	Load capacitance, 133.33 MHz < F <sub>OUT</sub> < 166.67 MHz	–	12	pF
C <sub>IN</sub>	Input capacitance	–	7	pF
t <sub>PU</sub>	Power-up time for all V <sub>DD</sub> 's to reach minimum specified voltage (power ramps must be monotonic)	0.05	50	ms

Note

- 1. Weak pull-down on all outputs.

### Electrical Characteristics

Parameter	Description	Test Conditions	Min	Max	Unit
V <sub>IL</sub>	Input LOW voltage		–	0.8	V
V <sub>IH</sub>	Input HIGH voltage		2.0	–	V
I <sub>IL</sub>	Input LOW current	V <sub>IN</sub> = 0 V	–	100	μA
I <sub>IH</sub>	Input HIGH current	V <sub>IN</sub> = V <sub>DD</sub>	–	50	μA
V <sub>OL</sub>	Output LOW voltage <sup>[2]</sup>	I <sub>OL</sub> = 8 mA	–	0.4	V
V <sub>OH</sub>	Output HIGH voltage <sup>[2]</sup>	I <sub>OH</sub> = –8 mA	2.4	–	V
I <sub>DD</sub>	Supply current	Unloaded outputs, REFIN = 66 MHz	–	45	mA
		Unloaded outputs, REFIN = 33 MHz	–	32	mA
		Unloaded outputs, REFIN = 20 MHz	–	18	mA

### Switching Characteristics

Parameter	Name	Test Conditions	Min	Typ	Max	Unit
1/t <sub>1</sub>	Output frequency	18-pF load	10	–	133.33	MHz
		12-pF load	–	–	166.67	MHz
	Duty cycle <sup>[3]</sup> = t <sub>2</sub> ÷ t <sub>1</sub>	Measured at V <sub>DD</sub> /2	40	50	60	%
t <sub>3</sub>	Rise time <sup>[3]</sup>	Measured between 0.8 V and 2.0 V	–	–	1.20	ns
t <sub>4</sub>	Fall time <sup>[3]</sup>	Measured between 0.8 V and 2.0 V	–	–	1.20	ns
t <sub>5</sub>	Output to output skew on rising edges <sup>[3]</sup>	All outputs equally loaded Measured at V <sub>DD</sub> /2	–	–	200	ps
t <sub>6</sub>	Delay, REFIN rising edge to output rising edge <sup>[3]</sup>	Measured at V <sub>DD</sub> /2 from REFIN to any output	–	–	±200	ps
t <sub>7</sub>	Device to device skew <sup>[3]</sup>	Measured at V <sub>DD</sub> /2 on the 1/2xREF pin of devices (pin 1)	–	–	400	ps
t <sub>J</sub>	Period jitter <sup>[3]</sup>	Measured at F <sub>out</sub> =133.33 MHz, loaded outputs, 18-pF load	–	–	±175	ps
t <sub>LOCK</sub>	PLL lock time <sup>[3]</sup>	Stable power supply, valid clocks presented on REFIN	–	–	1.0	ms

### Switching Waveforms

Figure 2. Duty Cycle Timing

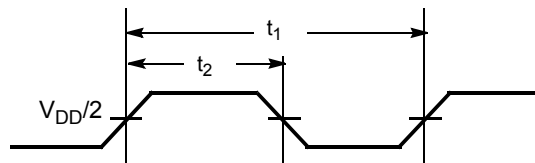

**Notes**

- 2. Parameter is guaranteed by design and characterization. It is not 100% tested in production.
- 3. All parameters are specified with equally loaded outputs.

Switching Waveforms (continued)

Figure 3. All Outputs Rise/Fall Time

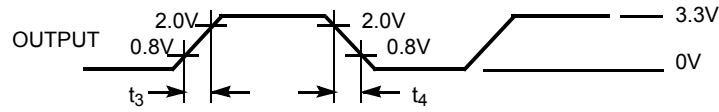

Figure 4. Output to Output Skew

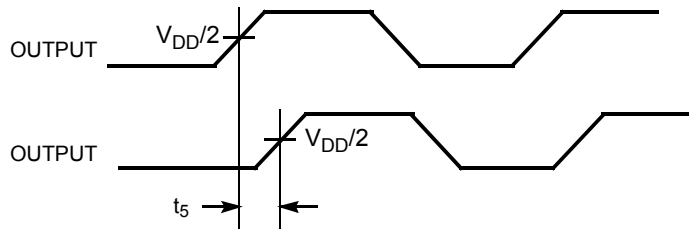

Figure 5. Input to Output Propagation Delay

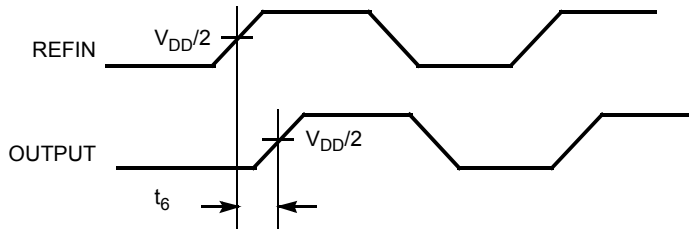
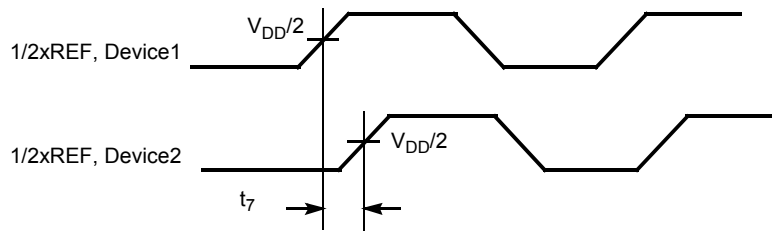
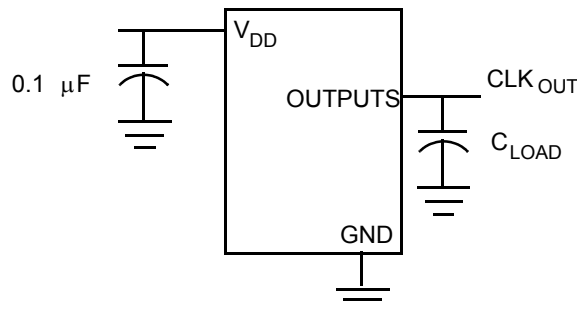

Figure 6. Device to Device Skew



Test Circuits

Figure 7. Test Circuit #1



**Ordering Information**

Ordering Code	Package Type	Operating Range
<b>Pb-free</b>		
CY2300SXC	8-pin 150-mil SOIC	Commercial (0 to 70 °C)
CY2300SXCT	8-pin 150-mil SOIC - Tape and Reel	Commercial (0 to 70 °C)

**Ordering Code Definitions**

CY 2300 S X C (T)

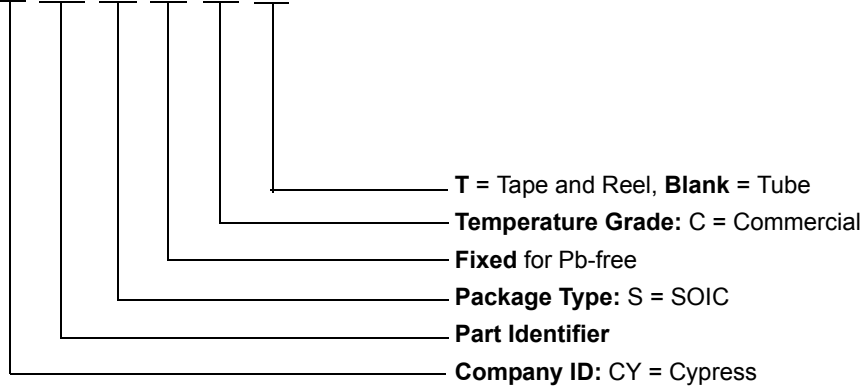

Package Drawing and Dimensions

Figure 7. 8-pin (150-Mil) SOIC S8

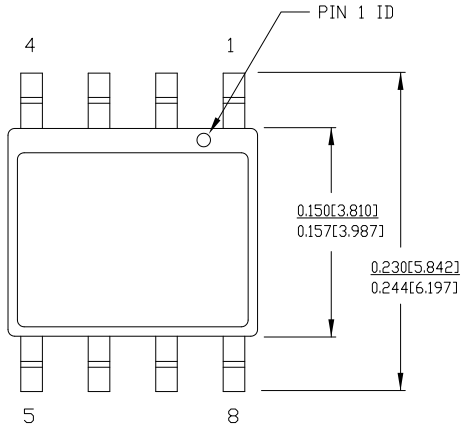

1. DIMENSIONS IN INCHES[MM] MIN. MAX.
2. PIN 1 ID IS OPTIONAL, ROUND ON SINGLE LEADFRAME RECTANGULAR ON MATRIX LEADFRAME
3. REFERENCE JEDEC MS-012
4. PACKAGE WEIGHT 0.07gms

PART #	
S08.15	STANDARD PKG.
SZ08.15	LEAD FREE PKG.

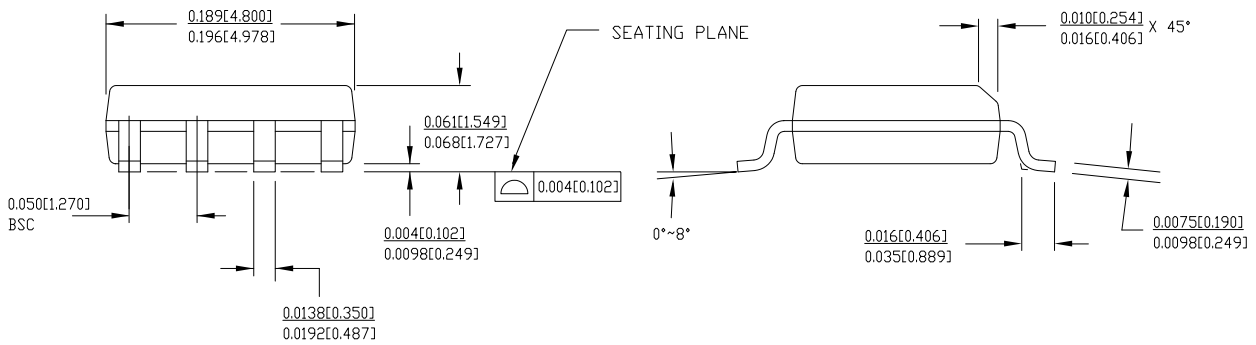

51-85066 \*D

## Acronyms

Acronym	Description
FBK	Feedback
OE	Output enable
PLL	Phase locked loop
REFIN	Reference input

## Reference Documents

Reference documents are available through your local Cypress sales representative. You can also direct your requests to [tsbusdev@cypress.com](mailto:tsbusdev@cypress.com).

Document Number	Document Title	Description
NA	NA	NA

## Document Conventions

### Units of Measure

Symbol	Unit of Measure
°C	degrees Celsius
Hz	Hertz
kHz	kilo Hertz
MHz	Mega Hertz
μA	micro Amperes
μF	micro Farads
μs	micro seconds
μV	micro Volts
mA	milli Amperes
mm	milli meters
ms	milli seconds
mV	milli Volts
ns	nano seconds
pA	pico Amperes
pF	pico Farads
ps	pico seconds
V	Volts

Document History Page

Document Title: CY2300 Phase-Aligned Clock Multiplier Document Number: 38-07252				
REV.	ECN	Orig. of Change	Submission Date	Description of Change
**	110517	SZV	01/07/02	Change from Spec number: 38-01039 to 38-07252
*A	121854	RBI	12/14/02	Power up requirements added to Operating Conditions Information
*B	246829	RGL	08/02/04	Added Lead Free Devices
*C	2568533	AESA	09/23/08	Updated template. Removed Selector Guide. Removed Operating Conditions for CY2300SI Industrial Temperature Devices. Removed Electrical Characteristics for CY2300SI Industrial Temperature Devices. Removed Switching Characteristics for CY2300SI Industrial Temperature Devices. Removed part number CY2300SC, CY2300SC, CY2300SI, CY2300SI, CY2300SXI and CY2300SXIT.
*D	3026183	BASH	09/01/2010	Removed "Benefits" from page 1. Added lower limit of 10MHz for 18pF load capacitance in <a href="#">Operating Conditions</a> on page 3. <a href="#">Ordering Code Definitions</a> added on page 5. <a href="#">Acronyms</a> , <a href="#">Reference Documents</a> and <a href="#">Document Conventions</a> added on page 7.



## Sales, Solutions, and Legal Information

### Worldwide Sales and Design Support

Cypress maintains a worldwide network of offices, solution centers, manufacturer's representatives, and distributors. To find the office closest to you, visit us at [cypress.com/sales](http://cypress.com/sales).

### Products

Automotive	<a href="http://cypress.com/go/automotive">cypress.com/go/automotive</a>
Clocks & Buffers	<a href="http://cypress.com/go/clocks">cypress.com/go/clocks</a>
Interface	<a href="http://cypress.com/go/interface">cypress.com/go/interface</a>
Lighting & Power Control	<a href="http://cypress.com/go/powerpsoc">cypress.com/go/powerpsoc</a> <a href="http://cypress.com/go/plc">cypress.com/go/plc</a>
Memory	<a href="http://cypress.com/go/memory">cypress.com/go/memory</a>
Optical & Image Sensing	<a href="http://cypress.com/go/image">cypress.com/go/image</a>
PSoC	<a href="http://cypress.com/go/psoc">cypress.com/go/psoc</a>
Touch Sensing	<a href="http://cypress.com/go/touch">cypress.com/go/touch</a>
USB Controllers	<a href="http://cypress.com/go/USB">cypress.com/go/USB</a>
Wireless/Rf	<a href="http://cypress.com/go/wireless">cypress.com/go/wireless</a>

### PSoC Solutions

[psoc.cypress.com/solutions](http://psoc.cypress.com/solutions)  
PSoC 1 | PSoC 3 | PSoC 5

---

© Cypress Semiconductor Corporation, 2002-2010. The information contained herein is subject to change without notice. Cypress Semiconductor Corporation assumes no responsibility for the use of any circuitry other than circuitry embodied in a Cypress product. Nor does it convey or imply any license under patent or other rights. Cypress products are not warranted nor intended to be used for medical, life support, life saving, critical control or safety applications, unless pursuant to an express written agreement with Cypress. Furthermore, Cypress does not authorize its products for use as critical components in life-support systems where a malfunction or failure may reasonably be expected to result in significant injury to the user. The inclusion of Cypress products in life-support systems application implies that the manufacturer assumes all risk of such use and in doing so indemnifies Cypress against all charges.

Any Source Code (software and/or firmware) is owned by Cypress Semiconductor Corporation (Cypress) and is protected by and subject to worldwide patent protection (United States and foreign), United States copyright laws and international treaty provisions. Cypress hereby grants to licensee a personal, non-exclusive, non-transferable license to copy, use, modify, create derivative works of, and compile the Cypress Source Code and derivative works for the sole purpose of creating custom software and or firmware in support of licensee product to be used only in conjunction with a Cypress integrated circuit as specified in the applicable agreement. Any reproduction, modification, translation, compilation, or representation of this Source Code except as specified above is prohibited without the express written permission of Cypress.

Disclaimer: CYPRESS MAKES NO WARRANTY OF ANY KIND, EXPRESS OR IMPLIED, WITH REGARD TO THIS MATERIAL, INCLUDING, BUT NOT LIMITED TO, THE IMPLIED WARRANTIES OF MERCHANTABILITY AND FITNESS FOR A PARTICULAR PURPOSE. Cypress reserves the right to make changes without further notice to the materials described herein. Cypress does not assume any liability arising out of the application or use of any product or circuit described herein. Cypress does not authorize its products for use as critical components in life-support systems where a malfunction or failure may reasonably be expected to result in significant injury to the user. The inclusion of Cypress' product in a life-support systems application implies that the manufacturer assumes all risk of such use and in doing so indemnifies Cypress against all charges.

Use may be limited by and subject to the applicable Cypress software license agreement.