



CY22393, CY223931, CY22394, CY22395

Three-PLL Serial-Programmable Flash-Programmable Clock Generator

Features

- Three integrated phase-locked loops (PLLs)
- Ultra wide divide counters (8-bit Q, 11-bit P, and 7-bit post divide)
- Improved linear crystal load capacitors
- Flash programmability with external programmer
- Field-programmable
- Low jitter, high accuracy outputs
- Power management options (Shutdown, OE, Suspend)
- Configurable crystal drive strength
- Frequency select through three external LVTTTL inputs
- 3.3V operation
- 16-pin TSSOP package
- CyClocksRT™ software support

Advanced Features

- 2-wire serial interface for in-system configurability
- Configurable output buffer
- Digital VCXO
- High frequency LVPECL output (CY22394 only)
- 3.3/2.5V outputs (CY22395 only)
- NiPdAu lead finish (CY223931)

Benefits

- Generates up to three unique frequencies on up to six outputs from an external source.
- Allows for 0 ppm frequency generation and frequency conversion in the most demanding applications.
- Improves frequency accuracy over temperature, age, process, and initial ppm offset.
- Nonvolatile programming enables easy customization, ultra-fast turnaround, performance tweaking, design timing margin testing, inventory control, lower part count, and more secure product supply. In addition, any part in the family can be programmed multiple times, which reduces programming errors and provides an easy upgrade path for existing designs.
- In-house programming of samples and prototype quantities is available using the CY3672 FTG Development Kit. Production quantities are available through Cypress Semiconductor's value-added distribution partners or by using third-party programmers from BP Microsystems, HiLo Systems, and others.
- Performance suitable for high-end multimedia, communications, industrial, A/D converters, and consumer applications.
- Supports numerous low power application schemes and reduces electromagnetic interference (EMI) by allowing unused outputs to be turned off.
- Adjust crystal drive strength for compatibility with virtually all crystals.
- 3-bit external frequency select options for PLL1, CLKA, and CLKB.
- Industry standard packaging saves on board space.
- Easy to use software support for design entry.
- 2-wire serial interface allows in-system programming into volatile configuration memory. All frequency settings can be changed, providing literally millions of frequency options.
- Adjust output buffer strength to lower EMI or improve timing margin.
- Fine tune crystal oscillator frequency by changing load capacitance.
- Differential output up to 400 MHz.
- Provides interfacing option for low voltage parts.

Selector Guide

Part Number	Outputs	Input Frequency Range	Output Frequency Range	Specifics
CY22393_C	6 CMOS	8 MHz–30 MHz (external crystal) 1 MHz–166 MHz (reference clock)	Up to 200 MHz	Commercial Temperature
CY22393_I	6 CMOS	8 MHz–30 MHz (external crystal) 1 MHz–166 MHz (reference clock)	Up to 166 MHz	Industrial Temperature
CY223931_I	6 CMOS	8 MHz–30 MHz (external crystal) 1 MHz–166 MHz (reference clock)	Up to 166 MHz	Industrial Temperature
CY22394_C	1 PECL/ 4 CMOS	8 MHz–30 MHz (external crystal) 1 MHz–166 MHz (reference clock)	100 MHz–400 MHz (PECL) Up to 200 MHz (CMOS)	Commercial Temperature
CY22394_I	1 PECL/ 4 CMOS	8 MHz–30 MHz (external crystal) 1 MHz–150 MHz (reference clock)	125 MHz–375 MHz (PECL) Up to 166 MHz (CMOS)	Industrial Temperature
CY22395_C	4 LVCMOS/ 1 CMOS	8 MHz–30 MHz (external crystal) 1 MHz–166 MHz (reference clock)	Up to 200 MHz (3.3V) Up to 133 MHz (2.5V)	Commercial Temperature
CY22395_I	4 LVCMOS/ 1 CMOS	8 MHz–30 MHz (external crystal) 1 MHz–150 MHz (reference clock)	Up to 166 MHz (3.3V) Up to 133 MHz (2.5V)	Industrial Temperature

Logic Block Diagram - CY22393 and CY223931

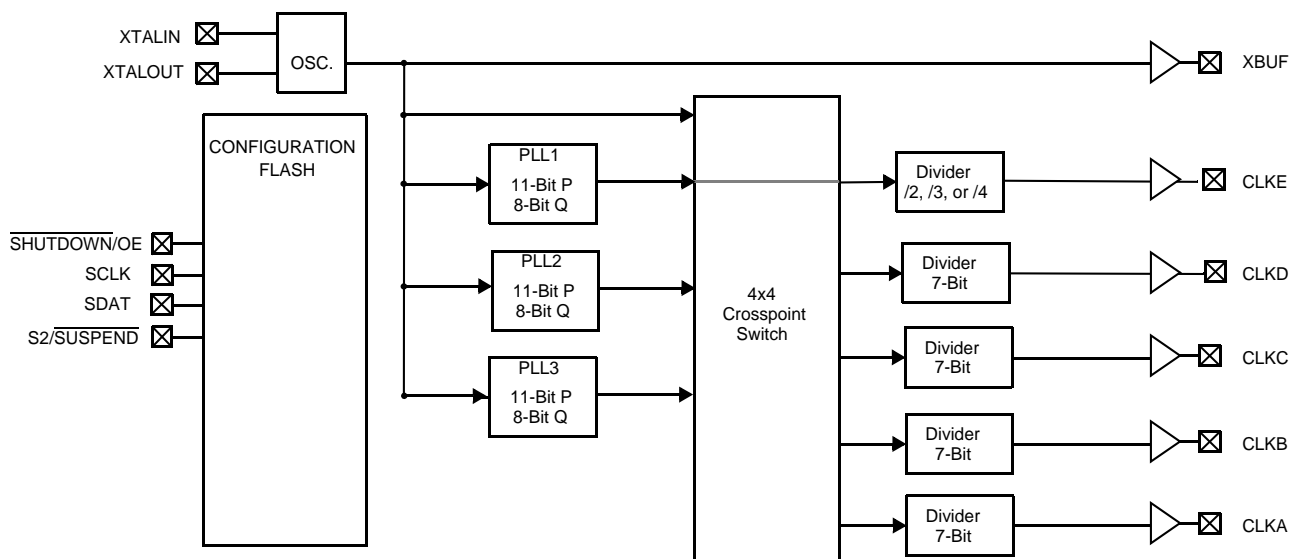

Logic Block Diagram - CY22394

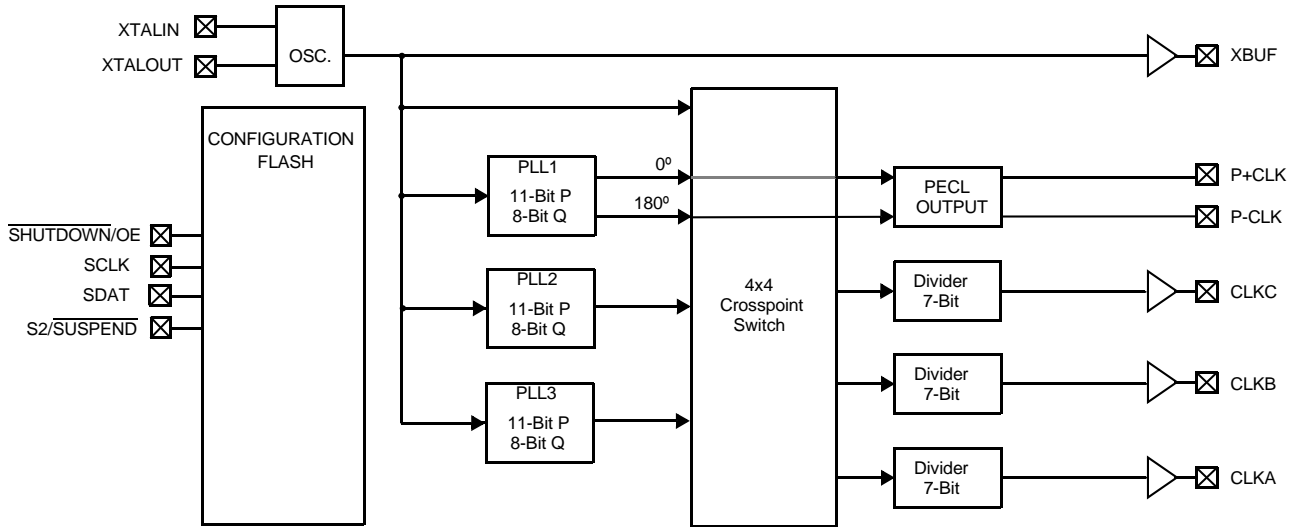

Logic Block Diagram - CY22395

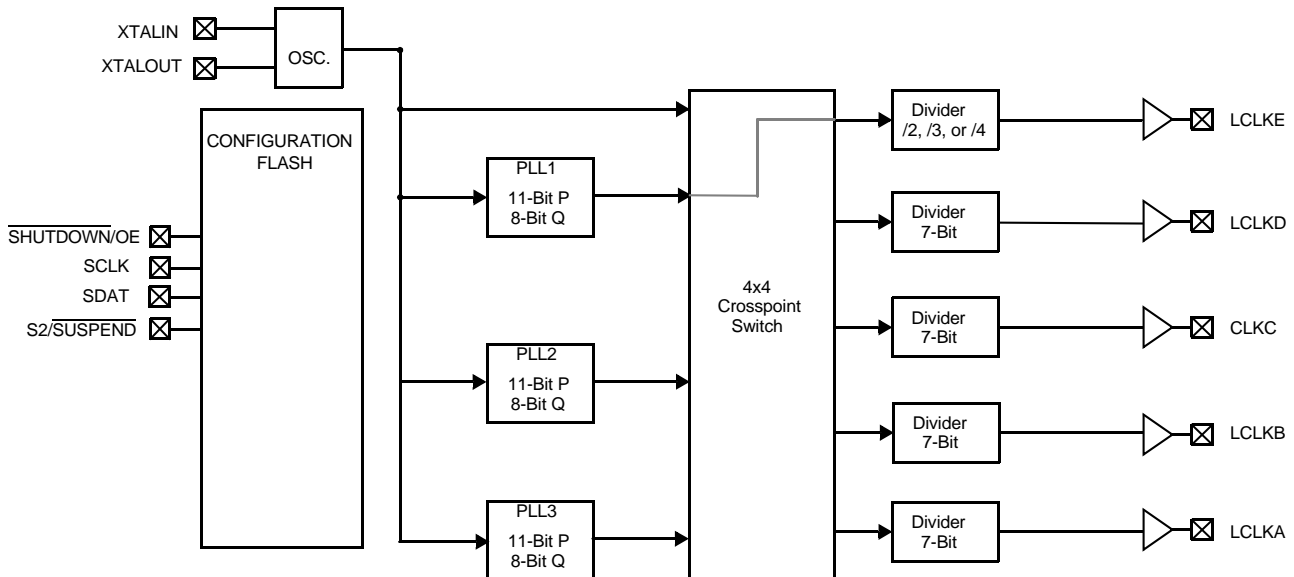

LCLKA, LCLKB, LCLKD, LCLKE referenced to LVDD

Pinouts

Figure 1. Pin diagram - 16-Pin TSSOP CY22393/CY223931/CY22394/CY22394

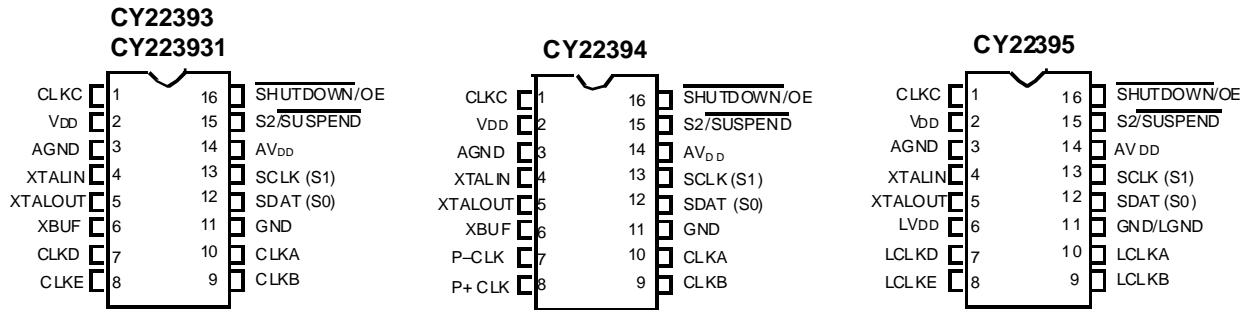

Pin Definitions

Name	Pin Number CY22393 CY223931	Pin Number CY22394	Pin Number CY22395	Description
CLKC	1	1	1	Configurable clock output C
V _{DD}	2	2	2	Power supply
AGND	3	3	3	Analog Ground
XTALIN	4	4	4	Reference crystal input or external reference clock input
XTALOUT	5	5	5	Reference crystal feedback
XBUF	6	6	N/A	Buffered reference clock output
LV _{DD}	N/A	N/A	6	Low voltage clock output power supply
CLKD or LCLKD	7	N/A	7	Configurable clock output D; LCLKD referenced to LVDD
P- CLK	N/A	7	N/A	LV PECL output ^[1]
CLKE or LCLKE	8	N/A	8	Configurable clock output E; LCLKE referenced to LVDD
P+ CLK	N/A	8	N/A	LV PECL output ^[1]
CLKB or LCLKB	9	9	9	Configurable clock output B; LCLKB referenced to LVDD
CLKA or LCLKA	10	10	10	Configurable clock output A; LCLKA referenced to LVDD
GND/LGND	11	11	11	Ground
SDAT (S0)	12	12	12	Serial Port Data. S0 value latched during start up
SCLK (S1)	13	13	13	Serial Port Clock. S1 value latched during start up
AV _{DD}	14	14	14	Analog Power Supply
S2/ SUSPEND	15	15	15	General purpose input for frequency control; bit 2. Optionally, Suspend mode control input
SHUTDOWN/ OE	16	16	16	Places outputs in tri-state condition and shuts down chip when LOW. Optionally, only places outputs in tri-state condition and does not shut down chip when LOW

Note

1. LVPECL outputs require an external termination network.

Operation

The CY22393, CY22394, and CY22395 are a family of parts designed as upgrades to the existing CY22392 device. These parts have similar performance to the CY22392, but provide advanced features to meet the needs of more demanding applications.

The clock family has three PLLs which, when combined with the reference, allow up to four independent frequencies to be output on up to six pins. These three PLLs are completely programmable.

The CY223931 is the CY22393 with NiPdAu lead finish.

Configurable PLLs

PLL1 generates a frequency that is equal to the reference divided by an 8-bit divider (Q) and multiplied by an 11-bit divider in the PLL feedback loop (P). The output of PLL1 is sent to two locations: the cross point switch and the PECL output (CY22394). The output of PLL1 is also sent to a $/2$, $/3$, or $/4$ synchronous post-divider that is output through CLKE. The frequency of PLL1 can be changed using serial programming or by external CMOS inputs, S0, S1, and S2. See the following section on [General Purpose Inputs](#) for more detail.

PLL2 generates a frequency that is equal to the reference divided by an 8-bit divider (Q) and multiplied by an 11-bit divider in the PLL feedback loop (P). The output of PLL2 is sent to the cross point switch. The frequency of PLL2 is changed using serial programming.

PLL3 generates a frequency that is equal to the reference divided by an 8-bit divider (Q) and multiplied by an 11-bit divider in the PLL feedback loop (P). The output of PLL3 is sent to the cross point switch. The frequency of PLL3 is changed using serial programming.

General Purpose Inputs

S2 is a general purpose input that is programmed to allow for two different frequency settings. Options that switches with this general purpose input are as follows: the frequency of PLL1, the output divider of CLKB, and the output divider of CLKA.

The two frequency settings are contained within an eight-row frequency table. The values of SCLK (S1) and SDAT (S0) pins are latched during start up and used as the other two indexes into this array.

CLKA and CLKB have seven-bit dividers that point to one of the two programmable settings (register 0 and register 1). Both clocks share a single register control and both must be set to register 0, or both must be set to register 1.

For example, the part may be programmed to use S0, S1, and S2 (0,0,0 to 1,1,1) to control eight different values of P and Q on PLL1. For each PLL1 P and Q setting, one of the two CLKA and CLKB divider registers can be chosen. Any divider change as a result of switching S0, S1, or S2 is guaranteed to be glitch free.

Crystal Input

The input crystal oscillator is an important feature of this family of parts because of its flexibility and performance features.

The oscillator inverter has programmable drive strength. This allows for maximum compatibility with crystals from various manufacturers, process, performance, and quality.

The input load capacitors are placed on-die to reduce external component cost. These capacitors are true parallel-plate capacitors for ultra-linear performance. These were chosen to reduce the frequency shift that occurs when nonlinear load capacitance interacts with load, bias, supply, and temperature changes. Nonlinear (FET gate) crystal load capacitors must not be used for MPEG, POTS dial tone, communications, or other applications that are sensitive to absolute frequency requirements.

The value of the load capacitors is determined by six bits in a programmable register. The load capacitance can be set with a resolution of 0.375pF for a total crystal load range of 6pF to 30pF.

For driven clock inputs, the input load capacitors can be completely bypassed. This allows the clock chip to accept driven frequency inputs up to 166 MHz. If the application requires a driven input, leave XTALOUT floating.

Digital VCXO

The serial programming interface is used to dynamically change the capacitor load value on the crystal. A change in crystal load capacitance corresponds with a change in the reference frequency.

For special pullable crystals specified by Cypress, the capacitance pull range is +150 ppm to -150 ppm from midrange.

Be aware that adjusting the frequency of the reference affects all frequencies on all PLLs in a similar manner since all frequencies are derived from the single reference.

Output Configuration

Under normal operation there are four internal frequency sources that are routed through a programmable cross point switch to any of the four programmable 7-bit output dividers. The four sources are: reference, PLL1, PLL2, and PLL3. The following is a description of each output.

CLKA's output originates from the cross point switch and goes through a programmable 7-bit post divider. The 7-bit post divider derives its value from one of the two programmable registers. [See the section on "General Purpose Inputs"](#) on page 5 for more information.

CLKB's output originates from the cross point switch and goes through a programmable 7-bit post divider. The 7-bit post divider derives its value from one of the two programmable registers. [See the section on "General Purpose Inputs"](#) on page 5 for more information.

CLKC's output originates from the cross point switch and goes through a programmable 7-bit post divider. The 7-bit post divider derives its value from one programmable register.

CLKD's output originates from the cross point switch and goes through a programmable 7-bit post divider. The 7-bit post divider derives its value from one programmable register. For the CY22394, CLKD is brought out as the complimentary version of

a LV PECL Clock referenced to CLKE, bypassing both the cross point switch and 7-bit post divider.

CLKE's output originates from PLL1 and goes through a post divider that may be programmed to /2, /3, or /4. For the CY22394, CLKE is brought out as a low voltage PECL Clock, bypassing the post divider.

XBUF is the buffered reference.

The Clock outputs have been designed to drive a single point load with a total lumped load capacitance of 15 pF. While driving multiple loads is possible with the proper termination it is generally not recommended.

Power-Saving Features

The $\overline{\text{SHUTDOWN/OE}}$ input tri-states the outputs when pulled LOW. If system shutdown is enabled, a LOW on this pin also shuts off the PLLs, counters, reference oscillator, and all other active components. The resulting current on the V_{DD} pins is less than 5 mA (typical). Relock the PLLs after leaving shutdown mode.

The $\overline{\text{S2/SUSPEND}}$ input is configured to shut down a customizable set of outputs and/or PLLs, when LOW. All PLLs and any of the outputs are shut off in nearly any combination. The only limitation is that if a PLL is shut off, all outputs derived from it must also be shut off. Suspending a PLL shuts off all associated logic, while suspending an output simply forces a tri-state condition.

With the serial interface, each PLL and/or output is individually disabled. This provides total control over the power savings.

Improving Jitter

Jitter Optimization Control is useful for mitigating problems related to similar clocks switching at the same moment, causing excess jitter. If one PLL is driving more than one output, the negative phase of the PLL can be selected for one of the outputs (CLKA–CLKD). This prevents the output edges from aligning, allowing superior jitter performance.

Power Supply Sequencing

For parts with multiple V_{DD} pins, there are no power supply sequencing requirements. The part is not fully operational until all V_{DD} pins have been brought up to the voltages specified in the [Operating Conditions Table](#) on page 13.

All grounds must be connected to the same ground plane.

CyClocksRT Software

CyClocksRT is our second generation software application that allows users to configure this family of devices. The easy-to-use interface offers complete control of the many features of this family including, but not limited to, input frequency, PLL and output frequencies, and different functional options. It checks data sheet frequency range limitations and automatically applies performance tuning. CyClocksRT also has a power estimation feature that allows the user to see the power consumption of a specific configuration. You can download a free copy of CyberClocks that includes CyClocksRT for free on Cypress's web site at www.cypress.com.

CyClocksRT is used to generate P, Q, and divider values used in serial programming. There are many internal frequency rules that are not documented in this data sheet, but are required for proper operation of the device. Check these rules by using the latest version of CyClocksRT.

Junction Temperature Limitations

It is possible to program this family such that the maximum Junction Temperature rating is exceeded. The package θ_{JA} is 115 °C/W. Use the CyClocksRT power estimation feature to verify that the programmed configuration meets the Junction Temperature and Package Power Dissipation maximum ratings.

Dynamic Updates

The output divider registers are not synchronized with the output clocks. Changing the divider value of an active output is likely cause a glitch on that output.

PLL P and Q data is spread between three bytes. Each byte becomes active on the acknowledge for that byte, so changing P and Q data for an active PLL is likely cause the PLL to try to lock on an out-of-bounds condition. For this reason, turn off the PLL being programmed during the update. Do this by setting the PLL*_En bit LOW.

PLL1, CLKA, and CLKB each have multiple registers supplying data. To program these resources safely, always program an inactive register, and then transition to that register. This allows these resources to stay active during programming.

The serial interface is active even with the $\overline{\text{SHUTDOWN/OE}}$ pin LOW as the serial interface logic uses static components and is completely self timed. The part does not meet the I_{DD5} current limit with transitioning inputs.

Memory Bitmap Definitions

Clk{A–D}_Div[6:0]

Each of the four main output clocks (CLKA–CLKD) features a 7-bit linear output divider. Any divider setting between 1 and 127 may be used by programming the value of the desired divider into this register. Odd divide values are automatically duty cycle corrected. Setting a divide value of zero powers down the divider and forces the output to a tri-state condition.

CLKA and CLKB have two divider registers, selected by the DivSel bit (which in turn is selected by S2, S1, and S0). This allows the output divider value to change dynamically. For the CY22394 device, ClkD_Div = 000001.

ClkE_Div[1:0]

CLKE has a simpler divider (see [Table 1](#)). For the CY22394, set ClkE_Div = 01.

Table 1. ClkE Divider

ClkE_Div[1:0]	ClkE Output
00	Off
01	PLL1 0° Phase/4
10	PLL1 0° Phase/2
11	PLL1 0° Phase/3

Clk*_FS[2:0]

Each of the four main output clocks (CLKA–CLKD) has a three-bit code that determines the clock sources for the output divider. The available clock sources are: Reference, PLL1, PLL2, and PLL3. Each PLL provides both positive and negative phased outputs, for a total of seven clock sources (see Table 2). Note that the phase is a relative measure of the PLL output phases. No absolute phase relation exists at the outputs.

Table 2. Clock Source

Clk*_FS[2:0]	Clock Source
000	Reference Clock
001	Reserved
010	PLL1 0° Phase
011	PLL1 180° Phase
100	PLL2 0° Phase
101	PLL2 180° Phase
110	PLL3 0° Phase
111	PLL3 180° Phase

Xbuf_OE

This bit enables the XBUF output when HIGH. For the CY22395, Xbuf_OE = 0.

PdnEn

This bit selects the function of the SHUTDOWN/OE pin. When this bit is HIGH, the pin is an active LOW shutdown control. When this bit is LOW, this pin is an active HIGH output enable control.

Clk*_ACAdj[1:0]

These bits modify the output predrivers, changing the duty cycle through the pads. These are nominally set to 01, with a higher value shifting the duty cycle higher. The performance of the nominal setting is guaranteed.

Clk*_DCAdj[1:0]

These bits modify the DC drive of the outputs. The performance of the nominal setting is guaranteed.

Table 3. Output Drive Strength

Clk*_DCAdj[1:0]	Output Drive Strength
00	–30% of nominal
01	Nominal
10	+15% of nominal
11	+50% of nominal

PLL*_Q[7:0]

PLL*_P[9:0]

PLL*_P0

These are the 8-bit Q value and 11-bit P values that determine the PLL frequency. The formula is:

$$F_{PLL} = F_{REF} \times \left(\frac{P_T}{Q_T}\right)$$

Equation 1

$$P_T = (2 \times (P + 3)) + P0$$

$$Q_T = Q + 2$$

PLL*_LF[2:0]

These bits adjust the loop filter to optimize the stability of the PLL. Table 4 can be used to guarantee stability. However, CyClocksRT uses a more complicated algorithm to set the loop filter for enhanced jitter performance. Use the Print Preview function in CyClocksRT to determine the charge pump settings for optimal jitter performance.

Table 4. Loop Filter Settings

PLL*_LF[2:0]	P _T Min	P _T Max
000	16	231
001	232	626
010	627	834
011	835	1043
100	1044	1600

PLL*_En

This bit enables the PLL when HIGH. If PLL2 or PLL3 are not enabled, then any output selecting the disabled PLL must have a divider setting of zero (off). Since the PLL1_En bit is dynamic, internal logic automatically turns off dependent outputs when PLL1_En goes LOW.

DivSel

This bit controls which register is used for the CLKA and CLKB dividers.

OscCap[5:0]

This controls the internal capacitive load of the oscillator. The approximate effective crystal load capacitance is:

$$C_{LOAD} = 6pF + (OscCap \times 0.375pF)$$

Equation 2

Set to zero for external reference clock.

OscDrv[1:0]

These bits control the crystal oscillator gain setting. These must always be set according to [Table 5](#). The parameters are the Crystal Frequency, Internal Crystal Parasitic Resistance (available from the manufacturer), and the OscCap setting during crystal start up, which occurs when power is applied, or after shutdown is released. If in doubt, use the next higher setting.

Table 5. Crystal Oscillator Gain Settings

OscCap	00H–20H		20H–30H		30H–40H	
	30Ω	60Ω	30Ω	60Ω	30Ω	60Ω
Crystal Freq\ R						
8–15 MHz	00	01	01	10	01	10
15–20 MHz	01	10	01	10	10	10
20–25 MHz	01	10	10	10	10	11
25–30 MHz	10	10	10	11	11	NA

Serial Programming Bitmaps — Summary Tables

Addr	DivSel	b7	b6	b5	b4	b3	b2	b1	b0	
08H	0	ClkA_FS[0]	ClkA_Div[6:0]							
09H	1	ClkA_FS[0]	ClkA_Div[6:0]							
0AH	0	ClkB_FS[0]	ClkB_Div[6:0]							
0BH	1	ClkB_FS[0]	ClkB_Div[6:0]							
0CH	–	ClkC_FS[0]	ClkC_Div[6:0]							
0DH	–	ClkD_FS[0]	ClkD_Div[6:0]							
0EH	–	ClkD_FS[2:1]	ClkC_FS[2:1]		ClkB_FS[2:1]		ClkA_FS[2:1]			
0FH	–	Clk{C,X}_ACAdj[1:0]	Clk{A,B,D,E}_ACAdj[1:0]		PdnEn	Xbuf_OE	ClkE_Div[1:0]			
10H	–	ClkX_DCAdj[1]	Clk{D,E}_DCAdj[1]		ClkC_DCAdj[1]		Clk{A,B}_DCAdj[1]			
11H	–	PLL2_Q[7:0]								
12H	–	PLL2_P[7:0]								
13H	–	Reserved	PLL2_En	PLL2_LF[2:0]			PLL2_PO	PLL2_P[9:8]		
14H	–	PLL3_Q[7:0]								
15H	–	PLL3_P[7:0]								
16H	–	Reserved	PLL3_En	PLL3_LF[2:0]			PLL3_PO	PLL3_P[9:8]		
17H	–	Osc_Cap[5:0]						Osc_Drv[1:0]		

Addr	S2 (1,0)	b7	b6	b5	b4	b3	b2	b1	b0
40H	000	PLL1_Q[7:0]							
41H		PLL1_P[7:0]							
42H		DivSel	PLL1_En	PLL1_LF[2:0]			PLL1_PO	PLL1_P[9:8]	
43H	001	PLL1_Q[7:0]							
44H		PLL1_P[7:0]							
45H		DivSel	PLL1_En	PLL1_LF[2:0]			PLL1_PO	PLL1_P[9:8]	
46H	010	PLL1_Q[7:0]							
47H		PLL1_P[7:0]							
48H		DivSel	PLL1_En	PLL1_LF[2:0]			PLL1_PO	PLL1_P[9:8]	

For external reference, the use [Table 6](#).

Table 6. Osc Drv for External Reference

External Freq (MHz)	1–25	25–50	50–90	90–166
OscDrv[1:0]	00	01	10	11

Reserved

These bits must be programmed LOW for proper operation of the device.

Addr	S2 (1,0)	b7	b6	b5	b4	b3	b2	b1	b0
49H	011	PLL1_Q[7:0]							
4AH		PLL1_P[7:0]							
4BH		DivSel	PLL1_En	PLL1_LF[2:0]			PLL1_PO	PLL1_P[9:8]	
4CH	100	PLL1_Q[7:0]							
4DH		PLL1_P[7:0]							
4EH		DivSel	PLL1_En	PLL1_LF[2:0]			PLL1_PO	PLL1_P[9:8]	
4FH	101	PLL1_Q[7:0]							
50H		PLL1_P[7:0]							
51H		DivSel	PLL1_En	PLL1_LF[2:0]			PLL1_PO	PLL1_P[9:8]	
52H	110	PLL1_Q[7:0]							
53H		PLL1_P[7:0]							
54H		DivSel	PLL1_En	PLL1_LF[2:0]			PLL1_PO	PLL1_P[9:8]	
55H	111	PLL1_Q[7:0]							
56H		PLL1_P[7:0]							
57H		DivSel	PLL1_En	PLL1_LF[2:0]			PLL1_PO	PLL1_P[9:8]	

Serial Bus Programming Protocol and Timing

The CY22393, CY22394 and CY22395 have a 2-wire serial interface for in-system programming. They use the SDAT and SCLK pins, and operate up to 400 kbit/s in Read or Write mode. Except for the data hold time, it is compliant with the I²C bus standard. The basic Write serial format is as follows:

Start Bit; 7-bit Device Address (DA); R/W Bit; Slave Clock Acknowledge (ACK); 8-bit Memory Address (MA); ACK; 8-bit Data; ACK; 8-bit Data in MA+1 if desired; ACK; 8-bit Data in MA+2; ACK; etc. until STOP Bit. The basic serial format is illustrated in [Figure 3](#) on page 11.

Default Startup Condition for the CY22393/931/94/95

The default (programmed) condition of each device is generally set by the distributor, who programs the device using a customer specified JEDEC file produced by CyClocksRT, Cypress's proprietary development software. Parts shipped by the factory are blank and unprogrammed. In this condition, all bits are set to 0, all outputs are tri-stated, and the crystal oscillator circuit is active.

While users can develop their own subroutine to program any or all of the individual registers as described in the following pages, it may be easier to simply use CyClocksRT to produce the required register setting file.

Device Address

The device address is a 7-bit value that is configured during Field Programming. By programming different device addresses, two or more parts are connected to the serial interface and can be independently controlled. The device address is combined with a read/write bit as the LSB and is sent after each start bit.

The default serial interface address is 69H, but must there be a conflict with any other devices in your system, this can also be changed using CyClocksRT.

Data Valid

Data is valid when the clock is HIGH, and can only be transitioned when the clock is LOW as illustrated in [Figure 4](#) on page 11.

Data Frame

Every new data frame is indicated by a start and stop sequence, as illustrated in [Figure 5](#) on page 11.

Start Sequence - Start Frame is indicated by SDAT going LOW when SCLK is HIGH. Every time a start signal is given, the next 8-bit data must be the device address (seven bits) and a R/W bit, followed by register address (eight bits) and register data (eight bits).

Stop Sequence - Stop Frame is indicated by SDAT going HIGH when SCLK is HIGH. A Stop Frame frees the bus for writing to another part on the same bus or writing to another random register address.

Acknowledge Pulse

During Write Mode the CY22393, CY22394, and CY22395 respond with an Acknowledge pulse after every eight bits. To do this, they pull the SDAT line LOW during the N*9th clock cycle, as illustrated in [Figure 6](#) on page 12. (N = the number of bytes transmitted). During Read Mode, the master generates the acknowledge pulse after the data packet is read.

Write Operations

Writing Individual Bytes

A valid write operation must have a full 8-bit register address after the device address word from the master, which is followed by an acknowledge bit from the slave (ack = 0/LOW). The next eight bits must contain the data word intended for storage. After the data word is received, the slave responds with another acknowledge bit (ack = 0/LOW), and the master must end the write sequence with a STOP condition.

Writing Multiple Bytes

To write multiple bytes at a time, the master must not end the write sequence with a STOP condition. Instead, the master sends multiple contiguous bytes of data to be stored. After each byte, the slave responds with an acknowledge bit, the same as after the first byte, and accepts data until the STOP condition responds to the acknowledge bit. When receiving multiple bytes, the CY22393, CY223931, CY22394, and CY22395 internally increment the register address.

Read Operations

Read operations are initiated the same way as Write operations except that the R/W bit of the slave address is set to '1' (HIGH). There are three basic read operations: current address read, random read, and sequential read.

Current Address Read

The CY22393, CY22394 and CY22395 have an onboard address counter that retains "1" more than the address of the last word access. If the last word written or read was word 'n', then a current address read operation returns the value stored in location 'n+1'. When the CY22393, CY22394 and CY22395 receive the slave address with the R/W bit set to a '1', they issue an acknowledge and transmit the 8-bit word. The master device does not acknowledge the transfer, but generates a STOP condition, which causes the CY22393, CY22394 and CY22395 to stop transmission.

Random Read

Through random read operations, the master may access any memory location. To perform this type of read operation, first set the word address. Do this by sending the address to the CY22393, CY22394 and CY22395 as part of a write operation. After the word address is sent, the master generates a START condition following the acknowledge. This terminates the write operation before any data is stored in the address, but not before setting the internal address pointer. Next, the master reissues the control byte with the R/W byte set to '1'. The CY22393, CY22394 and CY22395 then issue an acknowledge and transmit the 8-bit word. The master device does not acknowledge the transfer, but generates a STOP condition which causes the CY22393, CY22394 and CY22395 to stop transmission.

Sequential Read

Sequential read operations follow the same process as random reads except that the master issues an acknowledge instead of a STOP condition after transmitting the first 8-bit data word. This action increments the internal address pointer, and subsequently outputs the next 8-bit data word. By continuing to issue acknowledges instead of STOP conditions, the master serially reads the entire contents of the slave device memory. Note that register addresses outside of 08H to 1BH and 40H to 57H can be read from but are not real registers and do not contain configuration information. When the internal address pointer points to the FFH register, after the next increment, the pointer points to the 00H register.

Figure 2. Data Transfer Sequence on the Serial Bus

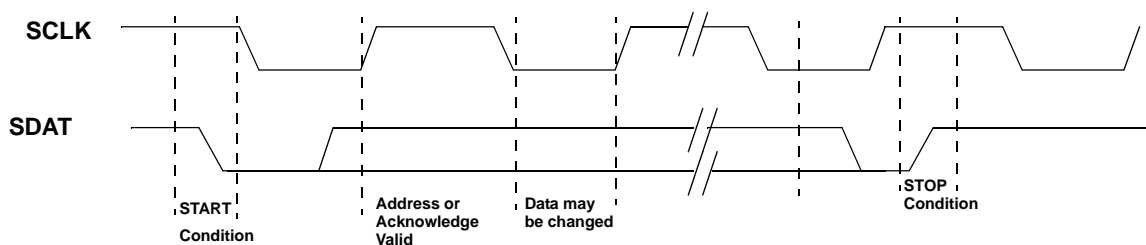

Figure 3. Data Frame Architecture

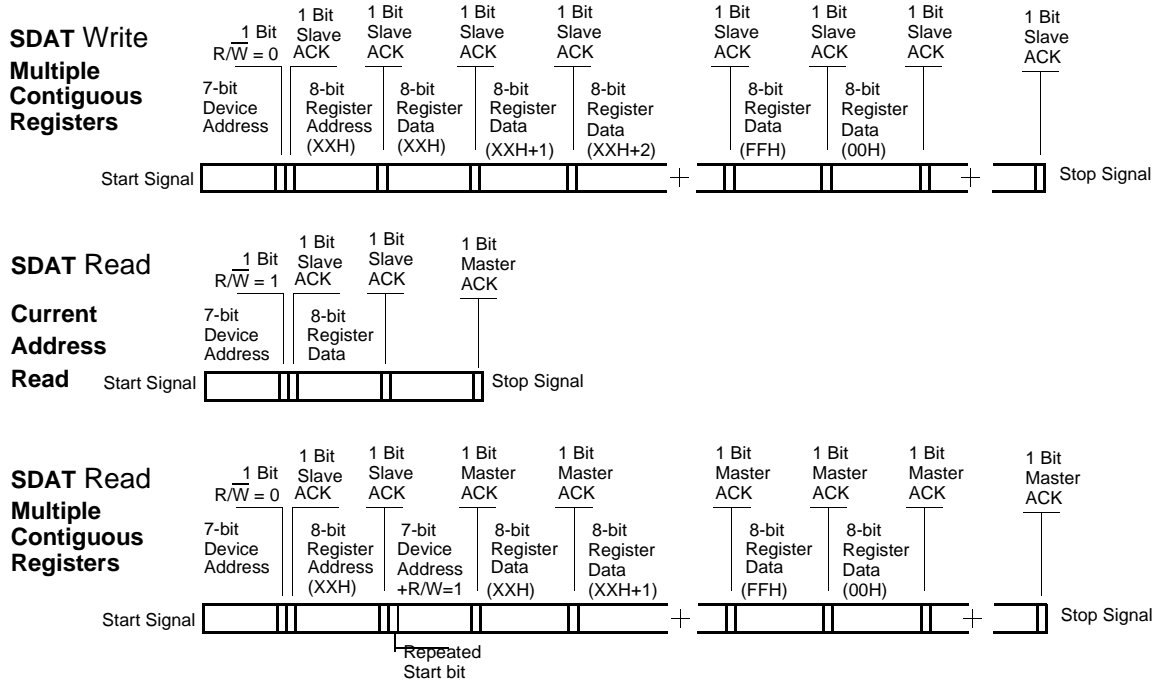
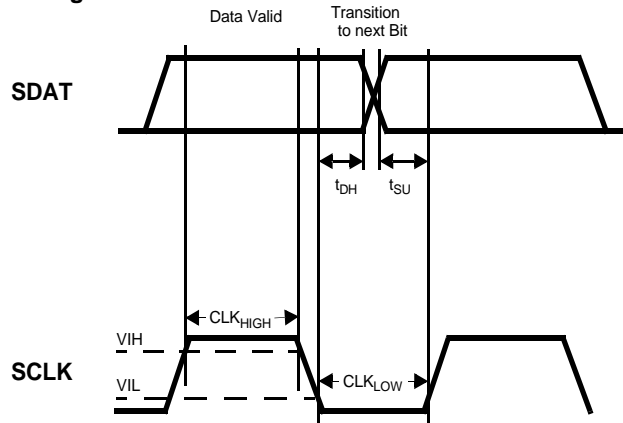

Figure 4. Data Valid and Data Transition Periods



Serial Programming Interface Timing

Figure 5. Start and Stop Frame

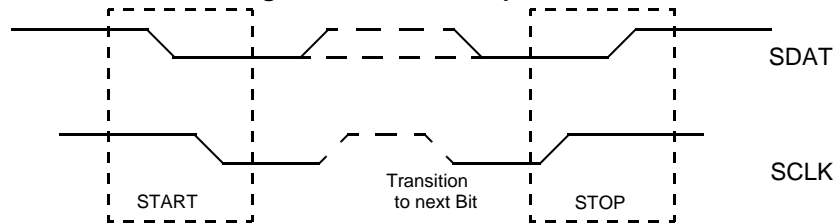
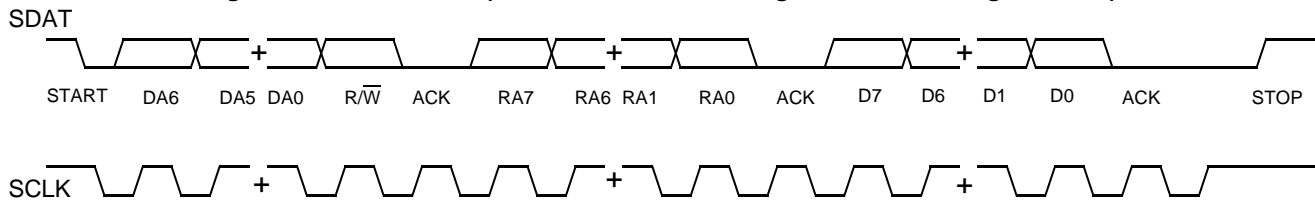

Figure 6. Frame Format (Device Address, R/W, Register Address, Register Data)



Serial Programming Interface Timing Specifications

Parameter	Description	Min	Max	Unit
f _{SCLK}	Frequency of SCLK	–	400	kHz
	Start mode time from SDA LOW to SCL LOW	0.6	–	μs
CLK _{LOW}	SCLK LOW period	1.3	–	μs
CLK _{HIGH}	SCLK HIGH period	0.6	–	μs
t _{SU}	Data transition to SCLK HIGH	100	–	ns
t _{DH}	Data hold (SCLK LOW to data transition)	100	–	ns
	Rise time of SCLK and SDAT	–	300	ns
	Fall time of SCLK and SDAT	–	300	ns
	Stop mode time from SCLK HIGH to SDAT HIGH	0.6	–	μs
	Stop mode to Start mode	1.3	–	μs

Absolute Maximum Conditions

Supply Voltage.....	-0.5V to +7.0V
DC Input Voltage	-0.5V to + (AV _{DD} + 0.5V)
Storage Temperature	-65°C to +125°C
Junction Temperature	125°C
Data Retention at T _j =125°C.....	> 10 years
Maximum Programming Cycles.....	100
Package Power Dissipation.....	350 mW

Static Discharge Voltage (per MIL-STD-883, Method 3015)	≥ 2000V
Latch up (per JEDEC 17)	≥ ±200 mA

Stresses exceeding Absolute Maximum Conditions may cause permanent damage to the device. These conditions are stress ratings only. Functional operation of the device at these or any other conditions beyond those indicated in the operation sections of this data sheet is not implied. Extended exposure to Absolute Maximum Conditions may affect reliability.

Operating Conditions

Parameter	Description	Part Numbers	Min	Typ	Max	Unit
V _{DD} /AV _{DD} /LV _{DD}	Supply Voltage	All	3.135	3.3	3.465	V
LV _{DD}	2.5V Output Supply Voltage	CY22395	2.375	2.5	2.625	V
T _A	Commercial Operating Temperature, Ambient	All	0	-	+70	°C
	Industrial Operating Temperature, Ambient	All	-40	-	+85	°C
C _{LOAD_OUT}	Maximum Load Capacitance	All	-	-	15	pF
f _{REF}	External Reference Crystal	All	8	-	30	MHz
	External Reference Clock, ^[3] Commercial	All	1	-	166	MHz
	External Reference Clock, ^[3] Industrial	All	1	-	150	MHz

3.3V Electrical Characteristics

Parameter	Description	Conditions ^[2]	Min	Typ	Max	Unit
I _{OH}	Output High Current ^[4]	V _{OH} = (L)V _{DD} - 0.5, (L)V _{DD} = 3.3V	12	24	-	mA
I _{OL}	Output Low Current ^[4]	V _{OL} = 0.5, (L)V _{DD} = 3.3V	12	24	-	mA
C _{XTAL_MIN}	Crystal Load Capacitance ^[4]	Capload at minimum setting	-	6	-	pF
C _{XTAL_MAX}	Crystal Load Capacitance ^[3]	Capload at maximum setting	-	30	-	pF
C _{IN}	Input Pin Capacitance ^[4]	Except crystal pins	-	7	-	pF
V _{IH}	HIGH-Level Input Voltage	CMOS levels, % of AV _{DD}	70%	-	-	AV _{DD}
V _{IL}	LOW-Level Input Voltage	CMOS levels, % of AV _{DD}	-	-	30%	AV _{DD}
I _{IH}	Input HIGH Current	V _{IN} = AV _{DD} - 0.3 V	-	<1	10	μA
I _{IL}	Input LOW Current	V _{IN} = +0.3 V	-	<1	10	μA
I _{OZ}	Output Leakage Current	Three-state outputs	-	-	10	μA
I _{DD}	Total Power Supply Current	3.3V Power Supply; 2 outputs at 20 MHz; 4 outputs at 40 MHz	-	50	-	mA
		3.3V Power Supply; 2 outputs at 166 MHz; 4 outputs at 83 MHz	-	100	-	mA
I _{DDS}	Total Power Supply Current in Shutdown Mode	Shutdown active	-	5	20	μA

2.5V Electrical Characteristics (CY22395 only)^[5]

Parameter	Description	Conditions	Min	Typ	Max	Unit
I _{OH_2.5}	Output High Current ^[4]	V _{OH} = LV _{DD} - 0.5, LV _{DD} = 2.5 V	8	16	-	mA
I _{OL_2.5}	Output Low Current ^[4]	V _{OL} = 0.5, LV _{DD} = 2.5 V	8	16	-	mA

Notes

- Unless otherwise noted, Electrical and Switching Characteristics are guaranteed across these operating conditions.
- External input reference clock must have a duty cycle between 40% and 60%, measured at V_{DD}/2.
- Guaranteed by design, not 100% tested.
- V_{DDL} is only specified and characterized at 3.3V ± 5% and 2.5V ± 5%. V_{DDL} may be powered at any value between 3.465 and 2.375.

3.3V Switching Characteristics

Parameter	Description	Conditions	Min	Typ	Max	Unit
1/t ₁	Output Frequency ^[4, 6]	Clock output limit, CMOS, Commercial	–	–	200	MHz
		Clock output limit, CMOS, Industrial	–	–	166	MHz
		Clock output limit, PECL, Commercial (CY22394 only)	100	–	400	MHz
		Clock output limit, PECL, Industrial (CY22394 only)	125	–	375	MHz
t ₂	Output Duty Cycle ^[4, 7]	Duty cycle for outputs, defined as t ₂ ÷ t ₁ , F _{out} < 100 MHz, divider ≥ 2, measured at V _{DD} /2	45%	50%	55%	
		Duty cycle for outputs, defined as t ₂ ÷ t ₁ , F _{out} > 100 MHz or divider = 1, measured at V _{DD} /2	40%	50%	60%	
t ₃	Rising Edge Slew Rate ^[4]	Output clock rise time, 20% to 80% of V _{DD}	0.75	1.4		V/ns
t ₄	Falling Edge Slew Rate ^[4]	Output clock fall time, 20% to 80% of V _{DD}	0.75	1.4		V/ns
t ₅	Output three-state Timing ^[4]	Time for output to enter or leave three-state mode after SHUTDOWN/OE switches	–	150	300	ns
t ₆	Clock Jitter ^[4, 8]	Peak-to-peak period jitter, CLK outputs measured at V _{DD} /2	–	400		ps
v ₇	P+/P– Crossing Point ^[4]	Crossing point referenced to V _{DD} /2, balanced resistor network (CY22394 only)	–0.2	0	0.2	V
t ₈	P+/P– Jitter ^[4, 8]	Peak-to-peak period jitter, P+/P– outputs measured at crossing point (CY22394 only)	–	200		ps
t ₉	Lock Time ^[4]	PLL Lock Time from Power up	–	1.0	3	ms

2.5V Switching Characteristics (CY22395 only)^[5]

Parameter	Description	Conditions	Min	Typ	Max	Unit
1/t _{1_2.5}	Output Frequency ^[4, 6]	Clock output limit, LVCMOS			133	MHz
t _{2_2.5}	Output Duty Cycle ^[4, 7]	Duty cycle for outputs, defined as t ₂ ÷ t ₁ measured at LV _{DD} /2	40%	50%	60%	
t _{3_2.5}	Rising Edge Slew Rate ^[4]	Output clock rise time, 20% to 80% of LV _{DD}	0.5	1.0		V/ns
t _{4_2.5}	Falling Edge Slew Rate ^[4]	Output clock fall time, 20% to 80% of LV _{DD}	0.5	1.0		V/ns

Notes

6. Guaranteed to meet 20%–80% output thresholds, duty cycle, and crossing point specifications.
7. Reference Output duty cycle depends on XTALIN duty cycle.
8. Jitter varies significantly with configuration. Reference Output jitter depends on XTALIN jitter and edge rate.

Switching Waveforms

Figure 7. All Outputs, Duty Cycle and Rise and Fall Time

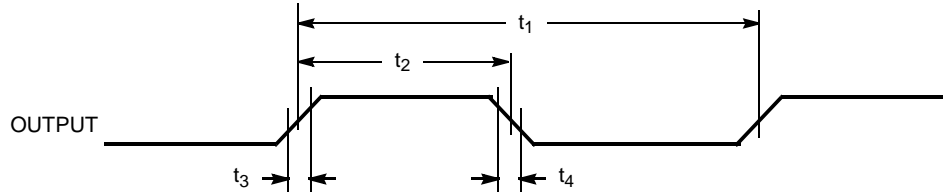

Figure 8. Output Tri-state Timing

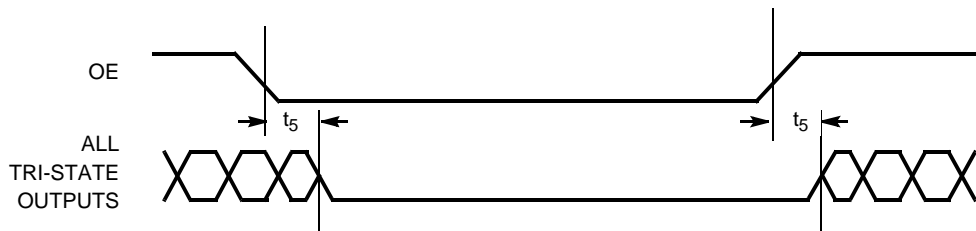

Figure 9. CLK Output Jitter

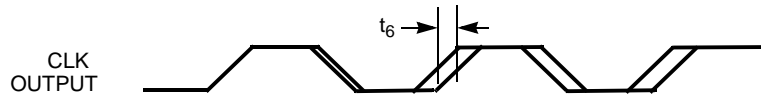

Figure 10. P+/P- Crossing Point and Jitter

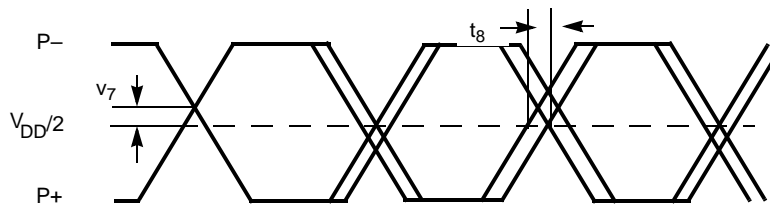
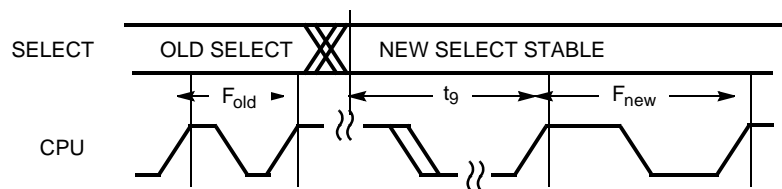
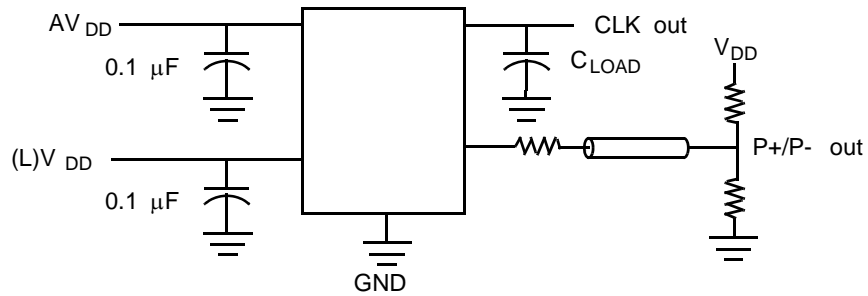

Figure 11. CPU Frequency Change



Test Circuit

Figure 12. Test Circuit



Ordering Information

Ordering Code	Package Type	Product Flow
CY22393ZC-xxx ^[9]	16-pin TSSOP	Commercial, 0 to 70°C
CY22393ZC-xxxT ^[9]	16-pin TSSOP - Tape and Reel	Commercial, 0 to 70°C
CY22393FC ^[9]	16-pin TSSOP	Commercial, 0 to 70°C
CY22393FCT ^[9]	16-pin TSSOP - Tape and Reel	Commercial, 0 to 70°C
CY22394FC ^[9]	16-pin TSSOP	Commercial, 0 to 70°C
CY22394FCT ^[9]	16-pin TSSOP - Tape and Reel	Commercial, 0 to 70°C
CY22395FC ^[9]	16-pin TSSOP	Commercial, 0 to 70°C
CY3672-USB	FTG Programmer	
CY3698	CY22392F, CY22393F, CY22394F, and CY22395F Adapter for CY3672-USB	
Pb-Free		
CY22393ZXC-xxx	16-pin TSSOP	Commercial, 0 to 70°C
CY22393ZXC-xxxT	16-pin TSSOP - Tape and Reel	Commercial, 0 to 70°C
CY22393ZXI-xxx	16-pin TSSOP	Industrial, -40 to 85°C
CY22393ZXI-xxxT	16-pin TSSOP - Tape and Reel	Industrial, -40 to 85°C
CY22393FXC	16-pin TSSOP	Commercial, 0 to 70°C
CY22393FXCT	16-pin TSSOP - Tape and Reel	Commercial, 0 to 70°C
CY22393FXI	16-pin TSSOP	Industrial, -40 to 85°C
CY22393FXIT	16-pin TSSOP - Tape and Reel	Industrial, -40 to 85°C
CY223931FXI	16-pin TSSOP with NiPdAu lead finish	Industrial, -40 to 85°C
CY22394ZXC-xxx	16-pin TSSOP	Commercial, 0 to 70°C
CY22394ZXC-xxxT	16-pin TSSOP - Tape and Reel	Commercial, 0 to 70°C
CY22394ZXI-xxx	16-pin TSSOP	Industrial, -40 to 85°C
CY22394ZXI-xxxT	16-pin TSSOP - Tape and Reel	Industrial, -40 to 85°C
CY22394FXC	16-pin TSSOP	Commercial, 0 to 70°C
CY22394FXCT	16-pin TSSOP - Tape and Reel	Commercial, 0 to 70°C
CY22394FXI	16-pin TSSOP	Industrial, -40 to 85°C
CY22394FXIT	16-pin TSSOP - Tape and Reel	Industrial, -40 to 85°C
CY22395ZXC-xxx	16-pin TSSOP	Commercial, 0 to 70°C
CY22395ZXC-xxxT	16-pin TSSOP - Tape and Reel	Commercial, 0 to 70°C
CY22395ZXI-xxx	16-pin TSSOP	Industrial, -40 to 85°C
CY22395ZXI-xxxT	16-pin TSSOP - Tape and Reel	Industrial, -40 to 85°C
CY22395FXC	16-pin TSSOP	Commercial, 0 to 70°C
CY22395FXCT	16-pin TSSOP - Tape and Reel	Commercial, 0 to 70°C
CY22395FXI	16-pin TSSOP	Industrial, -40 to 85°C
CY22395FXIT	16-pin TSSOP - Tape and Reel	Industrial, -40 to 85°C

Note
9. Not recommended for new designs.

Package Diagram

Figure 13. 16-Pin TSSOP 4.40 MM Body Z16.173

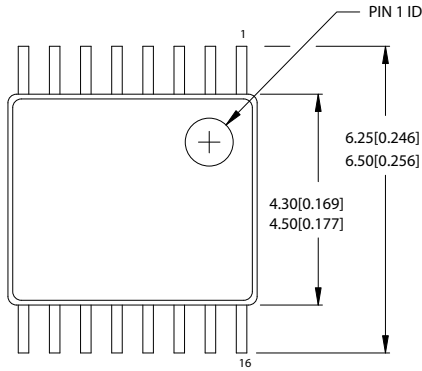

DIMENSIONS IN MM[INCHES] MIN.
MAX.

REFERENCE JEDEC MO-153

PACKAGE WEIGHT 0.05 gms

PART #	
Z16.173	STANDARD PKG.
ZZ16.173	LEAD FREE PKG.

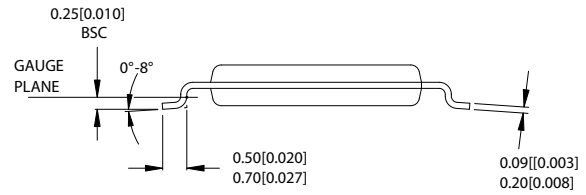
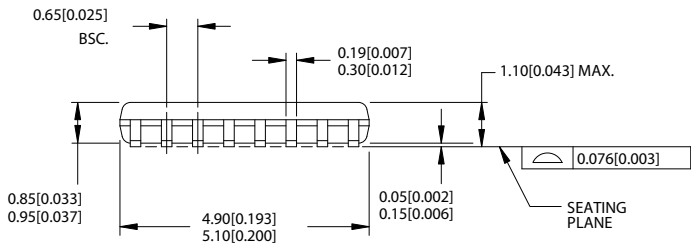

Document History Page

Document Title: CY22393, CY223931, CY22394, CY22395 Three-PLL Serial-Programmable Flash-Programmable Clock Generator				
Document Number: 38-07186				
REV.	ECN	Orig. of Change	Submission Date	Description of Change
**	111984	DSG	12/09/01	Change from Spec number: 38-01144 to 38-07186
*A	129388	RGL	10/13/03	Added timing information
*B	237755	RGL	See ECN	Added Lead-Free Devices
*C	848580	RGL	See ECN	Added references to I ² C; removed all references to SPI
*D	2584052	AESA/KVM	10/10/08	Updated template. Added Note "Not recommended for new designs." Added part number CY22393FC, and CY22393FCT in Ordering Information table. Removed part number CY22393FI, CY22393FIT, CY22393ZI-XXX, CY22393ZI-XXXT, CY22393FC, CY22393FCT, CY22392FI, CY22392FIT, CY22394ZC-XXX, CY22394ZC-XXXT, CY22394ZI-XXX, CY22394ZI-XXXT, CY22394FI, CY22394FIT, CY22395ZC-XXX, CY22395ZC-XXXT, CY22395ZI-XXX, CY22395ZI-XXXT, CY22395FC, CY22395FCT, and CY22395FI in Ordering Information table. Changed Lead-Free to Pb-Free. Changed serial interface hold time (TDH) from 0ns to 100ns. Replaced I ² C references with "2-wire serial interface"
*E	2634202	KVM/AESA	01/09/09	Changed title to include CY223931. Added CY223931 to page 1 features list. Added part number CY223931FXI. Added CY22393_1 to the Selector Guide (p.2), and changed the format of the part numbers. Added overbar to SUSPEND in Pin Definitions table

Sales, Solutions, and Legal Information

Worldwide Sales and Design Support

Cypress maintains a worldwide network of offices, solution centers, manufacturer’s representatives, and distributors. To find the office closest to you, visit us at cypress.com/sales.

Products

PSoC	psoc.cypress.com
Clocks & Buffers	clocks.cypress.com
Wireless	wireless.cypress.com
Memories	memory.cypress.com
Image Sensors	image.cypress.com

PSoC Solutions

General	psoc.cypress.com/solutions
Low Power/Low Voltage	psoc.cypress.com/low-power
Precision Analog	psoc.cypress.com/precision-analog
LCD Drive	psoc.cypress.com/lcd-drive
CAN 2.0b	psoc.cypress.com/can
USB	psoc.cypress.com/usb

© Cypress Semiconductor Corporation, 2001-2009. The information contained herein is subject to change without notice. Cypress Semiconductor Corporation assumes no responsibility for the use of any circuitry other than circuitry embodied in a Cypress product. Nor does it convey or imply any license under patent or other rights. Cypress products are not warranted nor intended to be used for medical, life support, life saving, critical control or safety applications, unless pursuant to an express written agreement with Cypress. Furthermore, Cypress does not authorize its products for use as critical components in life-support systems where a malfunction or failure may reasonably be expected to result in significant injury to the user. The inclusion of Cypress products in life-support systems application implies that the manufacturer assumes all risk of such use and in doing so indemnifies Cypress against all charges.

Any Source Code (software and/or firmware) is owned by Cypress Semiconductor Corporation (Cypress) and is protected by and subject to worldwide patent protection (United States and foreign), United States copyright laws and international treaty provisions. Cypress hereby grants to licensee a personal, non-exclusive, non-transferable license to copy, use, modify, create derivative works of, and compile the Cypress Source Code and derivative works for the sole purpose of creating custom software and/or firmware in support of licensee product to be used only in conjunction with a Cypress integrated circuit as specified in the applicable agreement. Any reproduction, modification, translation, compilation, or representation of this Source Code except as specified above is prohibited without the express written permission of Cypress.

Disclaimer: CYPRESS MAKES NO WARRANTY OF ANY KIND, EXPRESS OR IMPLIED, WITH REGARD TO THIS MATERIAL, INCLUDING, BUT NOT LIMITED TO, THE IMPLIED WARRANTIES OF MERCHANTABILITY AND FITNESS FOR A PARTICULAR PURPOSE. Cypress reserves the right to make changes without further notice to the materials described herein. Cypress does not assume any liability arising out of the application or use of any product or circuit described herein. Cypress does not authorize its products for use as critical components in life-support systems where a malfunction or failure may reasonably be expected to result in significant injury to the user. The inclusion of Cypress’ product in a life-support systems application implies that the manufacturer assumes all risk of such use and in doing so indemnifies Cypress against all charges.

Use may be limited by and subject to the applicable Cypress software license agreement.