

# Three-PLL General Purpose FLASH Programmable Clock Generator

## Features

- Three integrated phase-locked loops
- Ultra-wide divide counters (eight-bit Q, eleven-bit P, and seven-bit post divide)
- Improved linear crystal load capacitors
- Flash programmability
- Field programmability
- Low-jitter, high-accuracy outputs
- Power-management options (Shutdown, OE, Suspend)
- Configurable crystal drive strength
- Frequency select option through external LVTTTL Input
- 3.3V operation
- Eight-pin SOIC package
- CyClocks RT™ support

## Benefits

- Generates up to three unique frequencies on three outputs up to 200 MHz from an external source. Functional upgrade for current CY2081 family.
- Allows for 0 ppm frequency generation and frequency conversion under the most demanding applications

- Improves frequency accuracy over temperature, age, process, and initial offset
- Non-volatile programming enables easy customization, ultra-fast turnaround, performance tweaking, design timing margin testing, inventory control, lower part count, and more secure product supply. Can also be programmed multiple times which reduces programming errors and provides an easy upgrade path for existing designs
- In-house programming of samples and prototype quantities is available using the CY3672 FTG development Kit. Production quantities are available through Cypress's value-added distribution partners or by using third party programmers from BP Microsystems, HiLo Systems, and others.
- Performance suitable for high-end multimedia, communications, industrial, A/D converters, and consumer applications
- Supports numerous low-power application schemes and reduces EMI by allowing unused outputs to be turned off
- Adjust crystal drive strength for compatibility with virtually all crystals
- External frequency select option for PLL1, CLKA, and CLKB
- Industry standard supply voltage
- Industry standard packaging saves on board space
- Easy-to-use software support for design entry

## Logic Block Diagram

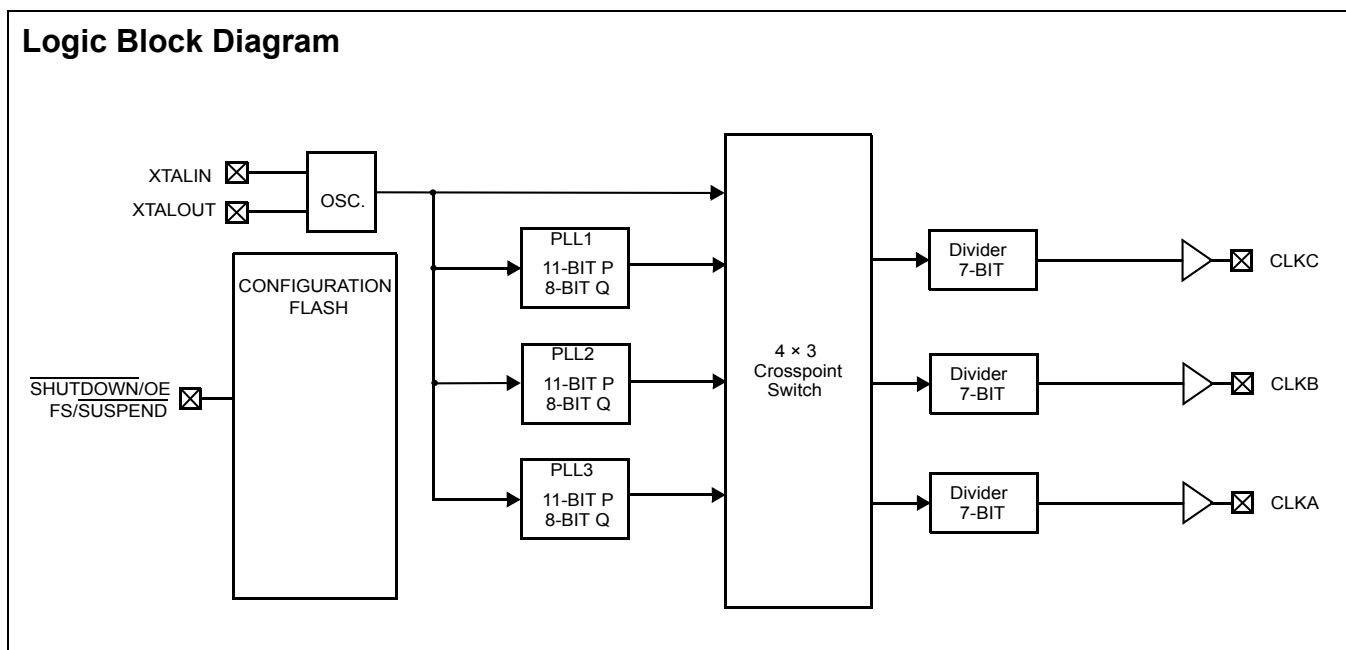

## Pinouts

**Figure 1. CY22381- 8-pin SOIC**

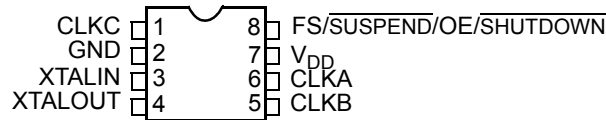

## Pin Definitions

Name	Pin Number	Description
CLKC	1	Configurable clock output C
GND	2	Ground
XTALIN	3	Reference crystal input or external reference clock input
XTALOUT	4	Reference crystal feedback (float if XTALIN is driven by external reference clock)
CLKB	5	Configurable clock output B
CLKA	6	Configurable clock output A
V <sub>DD</sub>	7	Power supply
FS/SUSPEND/OE/SHUTDOWN	8	General Purpose Input. Can be Frequency Control, Suspend mode control, Output Enable, or full-chip shutdown.

## Operation

The CY22381 is an upgrade to the existing CY2081. The new device has a wider frequency range, greater flexibility, improved performance, and incorporates many features that reduce PLL sensitivity to external system issues.

The device has three PLLs that allow each output to operate at an independent frequencies. These three PLLs are completely programmable.

### Configurable PLLs

PLL1 generates a frequency that is equal to the reference divided by an eight-bit divider (Q) and multiplied by an 11-bit divider in the PLL feedback loop (P). The output of PLL1 is sent to the crosspoint switch. The frequency of PLL1 can optionally be changed by using the external CMOS general purpose input. See the following section on “General-Purpose Input” for more detail.

PLL2 generates a frequency that is equal to the reference divided by an eight-bit divider (Q) and multiplied by an 11-bit divider in the PLL feedback loop (P). The output of PLL2 is sent to the crosspoint switch.

PLL3 generates a frequency that is equal to the reference divided by an eight-bit divider (Q) and multiplied by an 11-bit divider in the PLL feedback loop (P). The output of PLL3 is sent to the cross-point switch.

### General-Purpose Input

The CY22381 features an output control pin (pin 8) that can be programmed to control one of four features.

When programmed as a Frequency Select (FS), the input can select between two arbitrarily programmed frequency settings. The Frequency Select can change the following; the frequency of PLL1, the output divider of CLKB, and the output divider of

CLKA. Any divider change as a result of switching the FS input is guaranteed to be glitch free.

The general-purpose input can simultaneously control the Suspend feature, turning off a set of PLLs and outputs determined during programming.

When programmed as an Output Enable (OE) the input forces all outputs to be placed in a three-state condition when LOW.

When programmed as a Shutdown, the input forces a full chip shutdown mode when LOW.

### Crystal Input

The input crystal oscillator is an important feature of this device because of its flexibility and performance features.

The oscillator inverter has programmable drive strength. This allows for maximum compatibility with crystals from various manufacturers, processes, performances, and qualities.

The input load capacitors are placed on-die to reduce external component cost. These capacitors are true parallel-plate capacitors for ultra-linear performance. These were chosen to reduce the frequency shift that occurs when non-linear load capacitance interacts with load, bias, supply, and temperature changes. Non-linear (FET gate) crystal load capacitors must not be used for MPEG, POTS dial tone, communications, or other applications that are sensitive to absolute frequency requirements

The value of the load capacitors is determined by six bits in a programmable register. The load capacitance can be set with a resolution of 0.375pF for a total crystal load range of 6pF to 30pF.

For driven clock inputs the input load capacitors may be completely bypassed. This enables the clock chip to accept driven frequency inputs up to 166 MHz. If the application requires a driven input, then XTALOUT must be left floating.

## Output Configuration

Under normal operation there are four internal frequency sources that may be routed through a programmable crosspoint switch to any of the three outputs through programmable seven-bit output dividers. The four sources are: reference, PLL1, PLL2, and PLL3. The following is a description of each output.

CLKA's output originates from the crosspoint switch and goes through a programmable seven-bit post divider. The seven-bit post divider derives its value from one of two programmable registers controlled by FS.

CLKB's output originates from the crosspoint switch and goes through a programmable seven-bit post divider. The seven-bit post divider derives its value from one of two programmable registers controlled by FS.

CLKC's output originates from the crosspoint switch and goes through a programmable seven-bit post divider. The seven-bit post divider derives its value from one programmable register.

The Clock outputs have been designed to drive a single point load with a total lumped load capacitance of 15pF. While driving multiple loads is possible with the proper termination, it is generally not recommended.

## Power-Saving Features

When configured as OE, the general-purpose input three-states all outputs when pulled LOW. When configured as Shutdown, a LOW on this pin three-states all outputs and shuts off the PLLs, counters, the reference oscillator, and all other active components. The resulting current on the  $V_{DD}$  pins is less than

5  $\mu$ A (typical). After leaving shutdown mode, the PLLs will have to relock.

When configured as  $\overline{\text{SUSPEND}}$ , the general-purpose input can be configured to shut down a customizable set of outputs and/or PLLs, when LOW. All PLLs and any of the outputs can be shut off in nearly any combination. The only limitation is that if a PLL is shut off, all outputs derived from it must also be shut off. Suspending a PLL shuts off all associated logic, while suspending an output forces a three-state condition.

## Improving Jitter

Jitter Optimization Control is useful in mitigating problems related to similar clocks switching at the same moment and causing excess jitter. If one PLL is driving more than one output, the negative phase of the PLL can be selected for one of the outputs. This prevents the output edges from aligning, allowing superior jitter performance.

## CyClocks RT Software

CyClocks RT is our second-generation application that allows users to configure this device. The easy-to-use interface offers complete control of the many features of this family including input frequency, PLL and output frequencies, and different functional options. Data sheet frequency range limitations are checked and performance tuning is automatically applied. You can download a free copy of CyClocks RT on Cypress's web site at <http://www.cypress.com>.

### Maximum Ratings

Exceeding maximum ratings may shorten the useful life of the device. User guidelines are not tested.

Supply Voltage.....-0.5V to +7.0V  
 DC Input Voltage .....-0.5V to + (V<sub>DD</sub> + 0.5V)  
 Storage Temperature ..... -65°C to +125°C  
 Junction Temperature ..... 125°C

Data Retention at T<sub>j</sub> = 125°C ..... > 10 years  
 Maximum Programming Cycles..... 100  
 Package Power Dissipation..... 250 mW  
 Static Discharge Voltage  
 (per MIL-STD-883, Method 3015) ..... ≥ 2000V  
 Latch up (per JEDEC 17) ..... ≥ ±200 mA

### Operating Conditions

Parameter	Description	Min	Typ	Max	Unit
V <sub>DD</sub>	Supply Voltage	3.135	3.3	3.465	V
T <sub>A</sub>	Commercial Operating Temperature, Ambient	0	-	+70	°C
	Industrial Operating Temperature, Ambient	-40	-	+85	°C
C <sub>LOAD_OUT</sub>	Max. Load Capacitance	-	-	15	pF
f <sub>REF</sub>	External Reference Crystal	8	-	30	MHz
	External Reference Clock <sup>[2]</sup> , Commercial	1	-	166	MHz
	External Reference Clock <sup>[2]</sup> , Industrial	1	-	150	MHz
t <sub>PU</sub>	Power up time for all VDD's to reach minimum specified voltage (power ramps must be monotonic)	0.05	-	500	ms

### Electrical Characteristics

Parameter	Description	Conditions <sup>[1]</sup>	Min	Typ	Max	Unit
I <sub>OH</sub>	Output High Current <sup>[3]</sup>	V <sub>OH</sub> = V <sub>DD</sub> - 0.5, V <sub>DD</sub> = 3.3 V	12	24	-	mA
I <sub>OL</sub>	Output Low Current <sup>[3]</sup>	V <sub>OL</sub> = 0.5V, V <sub>DD</sub> = 3.3 V	12	24	-	mA
C <sub>XTAL_MIN</sub>	Crystal Load Capacitance <sup>[3]</sup>	Capload at minimum setting	-	6	-	pF
C <sub>XTAL_MAX</sub>	Crystal Load Capacitance <sup>[3]</sup>	Capload at maximum setting	-	30	-	pF
C <sub>IN</sub>	Input Pin Capacitance <sup>[3]</sup>	Except crystal pins	-	7	-	pF
V <sub>IH</sub>	HIGH-level Input Voltage	CMOS levels, % of V <sub>DD</sub>	70%	-	-	V <sub>DD</sub>
V <sub>IL</sub>	LOW-level Input Voltage	CMOS levels, % of V <sub>DD</sub>	-	-	30%	V <sub>DD</sub>
I <sub>IH</sub>	Input HIGH Current	V <sub>IN</sub> = V <sub>DD</sub> - 0.3 V	-	<1	10	µA
I <sub>IL</sub>	Input LOW Current	V <sub>IN</sub> = +0.3 V	-	<1	10	µA
I <sub>OZ</sub>	Output Leakage Current	Three-state outputs	-	-	10	µA
I <sub>DD</sub>	Total Power Supply Current	3.3 V Power Supply; 3 outputs at 50 MHz	-	35	-	mA
		3.3 V Power Supply; 3 outputs at 166 MHz	-	70	-	mA
I <sub>DDs</sub>	Total Power Supply Current in Shutdown Mode	Shutdown active	-	5	20	µA

**Notes**

1. Unless otherwise noted, Electrical and Switching Characteristics are guaranteed across these operating conditions.
2. External input reference clock must have a duty cycle between 40% and 60%, measured at V<sub>DD</sub>/2.
3. Guaranteed by design, not 100% tested.

### Switching Characteristics

Parameter	Name	Description	Min	Typ.	Max	Unit
1/t <sub>1</sub>	Output Frequency <sup>[3, 4]</sup>	Clock output limit, Commercial	–	–	200	MHz
		Clock output limit, Industrial	–	–	166	MHz
t <sub>2</sub>	Output Duty Cycle <sup>[3, 5]</sup>	Duty cycle for outputs, defined as t <sub>2</sub> ÷ t <sub>1</sub> , F <sub>out</sub> < 100 MHz, divider ≥ 2, measured at V <sub>DD</sub> /2	45%	50%	55%	
		Duty cycle for outputs, defined as t <sub>2</sub> ÷ t <sub>1</sub> , F <sub>out</sub> > 100 MHz or divider = 1, measured at V <sub>DD</sub> /2	40%	50%	60%	
t <sub>3</sub>	Rising Edge Slew Rate <sup>[3]</sup>	Output clock rise time, 20% to 80% of V <sub>DD</sub>	0.75	1.4	–	V/ns
t <sub>4</sub>	Falling Edge Slew Rate <sup>[3]</sup>	Output clock fall time, 20% to 80% of V <sub>DD</sub>	0.75	1.4	–	V/ns
t <sub>5</sub>	Output Three-state Timing <sup>[3]</sup>	Time for output to enter or leave three-state mode after SHUTDOWN/OE switches	–	150	300	ns
t <sub>6</sub>	Clock Jitter <sup>[3, 6]</sup>	Peak-to-peak period jitter, CLK outputs measured at V <sub>DD</sub> /2	–	200	–	ps
t <sub>7</sub>	Lock Time <sup>[3]</sup>	PLL Lock Time from Power up	–	1.0	3	ms

### Switching Waveforms

Figure 2. All Outputs, Duty Cycle and Rise and Fall Time

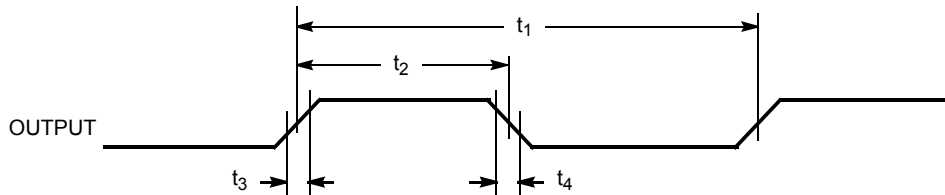

Figure 3. Output Three-State Timing

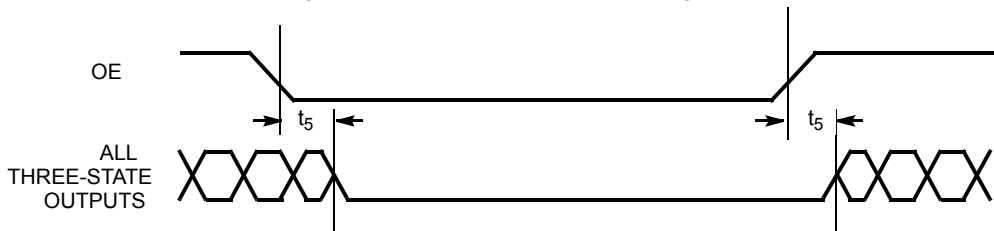
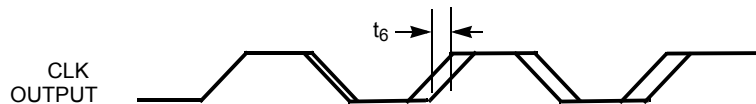

Figure 4. CLK Output Jitter



**Notes**

- 4. Guaranteed to meet 20% – 80% output thresholds and duty cycle specifications.
- 5. Reference Output duty cycle depends on XTALIN duty cycle.
- 6. Jitter varies significantly with configuration. Reference Output jitter depends on XTALIN jitter and edge rate.

Switching Waveforms (continued)

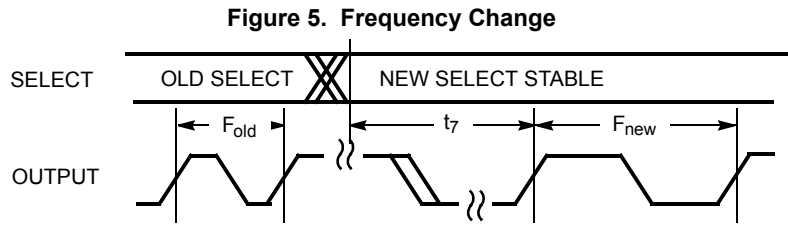

Test Circuit

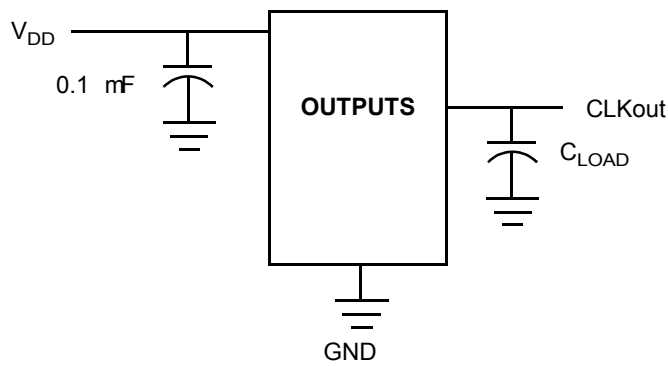

**Ordering Information**

Ordering Code	Package Type	Operating Range	Operating Voltage
CY22381FC <sup>[8]</sup>	8-SOIC	Commercial (T <sub>A</sub> =0°C to 70°C)	3.3V
CY22381FCT <sup>[8]</sup>	8-SOIC – Tape and Reel	Commercial (T <sub>A</sub> =0°C to 70°C)	3.3V
CY3672-USB	FTG Programmer		
CY3699	CY22381F Adapter for CY3672-USB		
<b>Pb-Free</b>			
CY22381FXI	8-SOIC with NiPdAu lead frame	Industrial (T <sub>A</sub> =-40°C to 85°C)	3.3V
CY22381FSZC <sup>[9]</sup>	8-SOIC	Commercial (T <sub>A</sub> =0°C to 70°C)	3.3V
CY22381FXC <sup>[9]</sup>	8-SOIC	Commercial (T <sub>A</sub> =0°C to 70°C)	3.3V
CY22381FXCT	8-SOIC – Tape and Reel	Commercial (T <sub>A</sub> =0°C to 70°C)	3.3V
CY22381FXI	8-SOIC	Industrial (T <sub>A</sub> =-40°C to 85°C)	3.3V
CY22381FXIT	8-SOIC – Tape and Reel	Industrial (T <sub>A</sub> =-40°C to 85°C)	3.3V
CY22381SXC-xxx <sup>[7]</sup>	8-SOIC	Commercial (T <sub>A</sub> =0°C to 70°C)	3.3V
CY22381SXC-xxxT <sup>[7]</sup>	8-SOIC – Tape and Reel	Commercial (T <sub>A</sub> =0°C to 70°C)	3.3V
CY22381SXI-xxx <sup>[7]</sup>	8-SOIC	Industrial (T <sub>A</sub> =-40°C to 85°C)	3.3V
CY22381SXI-xxxT <sup>[7]</sup>	8-SOIC – Tape and Reel	Industrial (T <sub>A</sub> =-40°C to 85°C)	3.3V

**Notes**

- 7. The CY22381SXC-xxx and CY22381SXI-xxx are factory programmed configurations. Factory programming is available for high-volume design opportunities of 100Ku/year or more in production. For more details, contact your local Cypress FAE or Cypress Sales Representative.
- 8. Not recommended for new designs.
- 9. The CY22381FSZC and CY22381FXC are identical. For new designs, use CY22381FXC.

Package Drawing and Dimensions

Figure 6. 8-Pin (150-Mil) SOIC S8

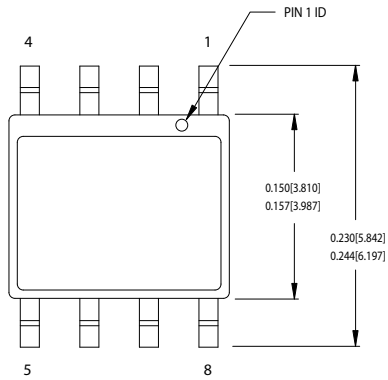

1. DIMENSIONS IN INCHES[MM] MIN. MAX.
2. PIN 1 ID IS OPTIONAL, ROUND ON SINGLE LEADFRAME RECTANGULAR ON MATRIX LEADFRAME
3. REFERENCE JEDEC MS-012
4. PACKAGE WEIGHT 0.07gms

PART #
S08.15 STANDARD PKG.
SZ08.15 LEAD FREE PKG.

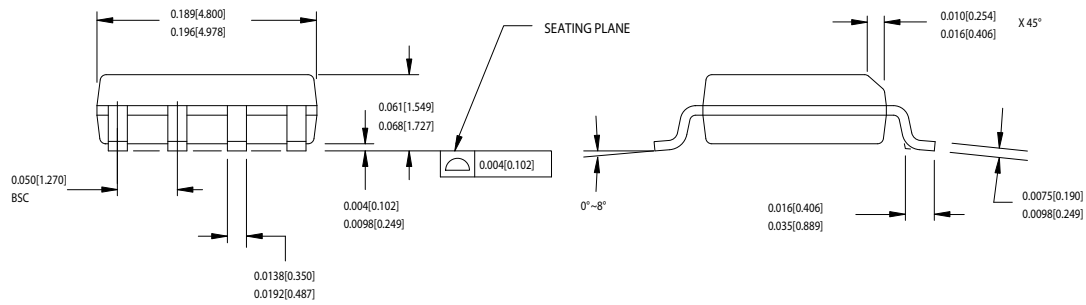

51-85066-°C



## Document History Page

Document Title: CY22381 Three-PLL General Purpose Flash Programmable Clock Generator Document Number: 38-07012				
REV.	ECN	Orig. of Change	Submission Date	Description of Change
**	106737	TLG	07/03/01	New data sheet
*A	108514	JWK	08/23/01	Updated based on characterization results Removed "Preliminary" heading Removed soldering temperature rating Split crystal load into two typical specs representing digital settings range Changed t <sub>5</sub> max to 300 ns Changed t <sub>6</sub> typical to 200 ps Changed t <sub>7</sub> typical to 1.0 ms
*B	110053	CKN	12/10/01	Changed from preliminary to final
*C	121863	RBI	12/14/02	Added power up requirements to Operating Conditions information
*D	279431	RGL	See ECN	Added lead-free devices
*E	2584052	AESA	10/10/08	Updated template. Added Note 8 and 9. Added part number CY22381FC, CY22381FCT, CY3672-USB, CY3699, CY22381FSZC in ordering information table. Removed part number CY22381FI, CY22381FIT, CY22381SC-xxx, CY22381SC-xxxT, CY22381SI-xxx, and CY22381SI-xxxT in Ordering Information table. Added CY223811FXI (NiPdAu lead frame). Changed Lead-Free to Pb-Free.

## Sales, Solutions, and Legal Information

### Worldwide Sales and Design Support

Cypress maintains a worldwide network of offices, solution centers, manufacturer's representatives, and distributors. To find the office closest to you, visit us at [cypress.com/sales](http://cypress.com/sales).

### Products

PSoC	<a href="http://psoc.cypress.com">psoc.cypress.com</a>
Clocks & Buffers	<a href="http://clocks.cypress.com">clocks.cypress.com</a>
Wireless	<a href="http://wireless.cypress.com">wireless.cypress.com</a>
Memories	<a href="http://memory.cypress.com">memory.cypress.com</a>
Image Sensors	<a href="http://image.cypress.com">image.cypress.com</a>

### PSoC Solutions

General	<a href="http://psoc.cypress.com/solutions">psoc.cypress.com/solutions</a>
Low Power/Low Voltage	<a href="http://psoc.cypress.com/low-power">psoc.cypress.com/low-power</a>
Precision Analog	<a href="http://psoc.cypress.com/precision-analog">psoc.cypress.com/precision-analog</a>
LCD Drive	<a href="http://psoc.cypress.com/lcd-drive">psoc.cypress.com/lcd-drive</a>
CAN 2.0b	<a href="http://psoc.cypress.com/can">psoc.cypress.com/can</a>
USB	<a href="http://psoc.cypress.com/usb">psoc.cypress.com/usb</a>

© Cypress Semiconductor Corporation, 2001-2008. The information contained herein is subject to change without notice. Cypress Semiconductor Corporation assumes no responsibility for the use of any circuitry other than circuitry embodied in a Cypress product. Nor does it convey or imply any license under patent or other rights. Cypress products are not warranted nor intended to be used for medical, life support, life saving, critical control or safety applications, unless pursuant to an express written agreement with Cypress. Furthermore, Cypress does not authorize its products for use as critical components in life-support systems where a malfunction or failure may reasonably be expected to result in significant injury to the user. The inclusion of Cypress products in life-support systems application implies that the manufacturer assumes all risk of such use and in doing so indemnifies Cypress against all charges.

Any Source Code (software and/or firmware) is owned by Cypress Semiconductor Corporation (Cypress) and is protected by and subject to worldwide patent protection (United States and foreign), United States copyright laws and international treaty provisions. Cypress hereby grants to licensee a personal, non-exclusive, non-transferable license to copy, use, modify, create derivative works of, and compile the Cypress Source Code and derivative works for the sole purpose of creating custom software and/or firmware in support of licensee product to be used only in conjunction with a Cypress integrated circuit as specified in the applicable agreement. Any reproduction, modification, translation, compilation, or representation of this Source Code except as specified above is prohibited without the express written permission of Cypress.

Disclaimer: CYPRESS MAKES NO WARRANTY OF ANY KIND, EXPRESS OR IMPLIED, WITH REGARD TO THIS MATERIAL, INCLUDING, BUT NOT LIMITED TO, THE IMPLIED WARRANTIES OF MERCHANTABILITY AND FITNESS FOR A PARTICULAR PURPOSE. Cypress reserves the right to make changes without further notice to the materials described herein. Cypress does not assume any liability arising out of the application or use of any product or circuit described herein. Cypress does not authorize its products for use as critical components in life-support systems where a malfunction or failure may reasonably be expected to result in significant injury to the user. The inclusion of Cypress' product in a life-support systems application implies that the manufacturer assumes all risk of such use and in doing so indemnifies Cypress against all charges.

Use may be limited by and subject to the applicable Cypress software license agreement.