

## Three-PLL General-Purpose EPROM-Programmable Clock Generator

### Features

- **Factory-EPROM configurable for quick availability and prototyping**
- **General purpose clock synthesizer for all applications – such as modems, disk drives, CD-ROM drives, Video CD players, games, set-top boxes, data/telecommunications, etc.**
- **Three independent configurable clock outputs**
- **Outputs ranging from 500 kHz to 100 MHz (5V) and up to 80 MHz for 3.3V operation**
- **Configurable output control pin (pin 8) can be used as an output enable, power-down, suspend or select line.**
- **Phase-locked loop oscillator input derived from external crystal (10 MHz to 25 MHz) or external reference clock (1 MHz to 30 MHz)**
- **3.3V or 5V operation (factory configured)**
- **8-pin 150-mil packaging achieves minimum footprint for space-critical applications**
- **Sophisticated internal loop filter requires no external components or manufacturing tweaks as commonly required with external filters**

### Functional Description

The CY2081 is a general-purpose clock synthesizer designed for use in applications such as modems, disk drives, CD-ROM drives, Video CD players, games, set-top boxes and data/telecommunications. This device offers three configurable clock outputs in an 8-pin 150-mil SOIC package and can be config-

ured to operate off either a 3.3V or 5V power supply. The on-chip reference oscillator is designed for 10 MHz to 25 MHz crystals. Alternatively, a reference clock between 1 MHz and 30 MHz can be used.

The CY2081 also features an output control pin (pin 8), which can be configured as an output enable, power down, frequency select, or suspend input. This gives the user the ability to three-state the output, power down the device, change the CLKA output frequency during operation, or suspend any of the outputs. Asserting the PD input will result in all the PLLs and the outputs being shut down. The PLLs will have to re-lock when the  $\overline{PD}$  input is deasserted.

The CY2081 outputs three clocks: CLKA, CLKB, and CLKC, whose frequencies can possess any value within the specified range. Additionally, the reference frequency can be obtained on any output. Custom configurations with user-defined features and frequencies can be obtained by filling out the custom configuration form located at the back of this data sheet and contacting your local Cypress representative.

The CY2081 can replace multiple Metal Can Oscillators (MCO) in a synchronous system, providing cost and board space savings to manufacturers. Hence, this device is ideally suited for applications that require multiple, accurate, and stable clocks synthesized from low-cost generators in small packages. A hard disk drive is an example of such an application. In this case, CLKA drives the PLL in the Read Controller, while CLKB and CLKC drive the MCU and associated sequencers.

Consider using the CY2291, CY2292, or CY2907 for applications that require more than three output clocks.

### Logic Block Diagram

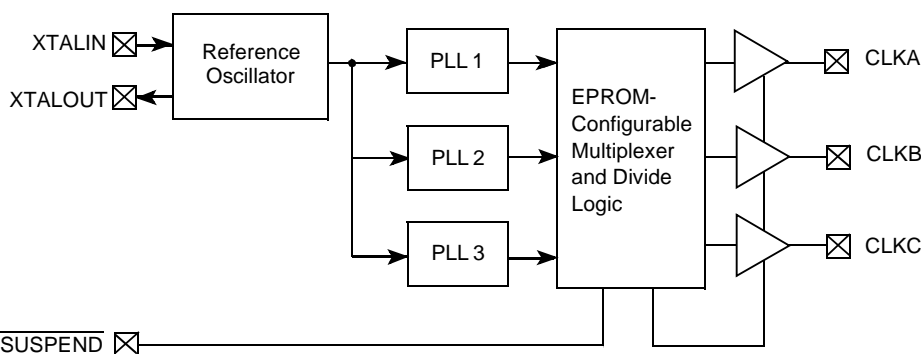

### Pin Configuration

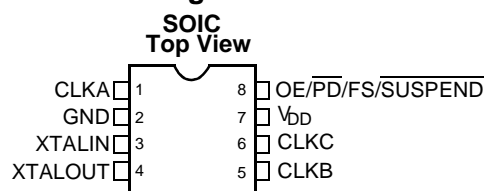

**Pin Summary**

Name	Number	Description
CLKA	1	Configurable Clock Output
GND	2	Ground
XTALIN <sup>[1]</sup>	3	Reference Crystal Input or External Reference Clock Input
XTALOUT <sup>[1,2]</sup>	4	Reference Crystal Feedback
CLKB	5	Configurable Clock Output
CLKC	6	Configurable Clock Output
V <sub>DD</sub>	7	Voltage Supply
OE / PD / FS / SUSPEND	8	Output control pin; either active-HIGH Output Enable, active-LOW power down, CLKA Frequency Select, or active-LOW Suspend input

**Maximum Ratings**

(Above which the useful life may be impaired. For user guidelines, not tested.)

Supply Voltage ..... -0.5V to +7.0V

DC Input Voltage ..... -0.5V to V<sub>DD</sub>+0.5V

Storage Temperature ..... -65°C to +150°C

Junction Temperature ..... 150°C

Static Discharge Voltage ..... >2000V  
(per MIL-STD-883, Method 3015)

**Operating Conditions<sup>[3]</sup>**

Parameter	Description	Min.	Max.	Unit
V <sub>DD</sub>	Supply Voltage	4.5 (3.0)	5.5 (3.6)	V
T <sub>A</sub>	Operating Temperature, Ambient	0	70	°C
C <sub>L</sub>	Max. Load Capacitance per output		25 (15)	pF
f <sub>REF</sub>	External Reference Crystal	10.0	25.0	MHz
f <sub>REF</sub>	External Reference Clock <sup>[4, 5]</sup>	1.0	30.0	MHz

**Electrical Characteristics** V<sub>DD</sub> = 5V (3.3V) ±10%, T<sub>A</sub> = 0°C to +70°C

Parameter	Description	Conditions	Min.	Typ.	Max.	Unit
V <sub>OH</sub>	HIGH-Level Output Voltage	I <sub>OH</sub> = -4.0 mA	2.4			V
V <sub>OL</sub>	LOW-Level Output Voltage	I <sub>OL</sub> = 4.0 mA			0.4	V
V <sub>IH</sub>	HIGH-Level Input Voltage <sup>[6]</sup>	Except Crystal Pins	2.0			V
V <sub>IL</sub>	LOW-Level Input Voltage <sup>[6]</sup>	Except Crystal Pins			0.8	V
I <sub>IH</sub>	Input HIGH Current	V <sub>IN</sub> = V <sub>DD</sub> - 0.5V		<100	150	μA
I <sub>IL</sub>	Input LOW Current	V <sub>IN</sub> = 0.5V		<100	150	μA
I <sub>OZ</sub>	Output Leakage Current	Three State Outputs			250	μA
I <sub>DD</sub>	V <sub>DD</sub> Supply Current <sup>[7]</sup>	V <sub>DD</sub> = V <sub>DD</sub> max. 5V (3.3V) operation, C <sub>L</sub> = 25 pF (15 pF)		40 (24)	60 (40)	mA
I <sub>DDS</sub>	V <sub>DD</sub> Power Supply Current in Power-down Mode	Power-down Active, 5V Operation		100	200	μA

**Notes:**

- For best accuracy, use a parallel-resonant crystal, C<sub>L</sub>=17 pF.
- Float XTALOUT pin if XTALIN is driven by reference clock (as opposed to an external crystal).
- Electrical parameters are guaranteed with these operating conditions. Values for 3.3V operation are shown in parentheses.
- External input reference clock must have a duty cycle between 40% and 60%, measured at V<sub>DD</sub>/2.
- Please refer to application note "Crystal Oscillator Topics" for information on AC-coupling the external input reference clock.
- Xtal inputs have CMOS thresholds.
- Load = max, typical configuration, f<sub>REF</sub> = 14.318 MHz. Specific configurations may vary.

**Switching Characteristics<sup>[8]</sup>**

Parameter	Name	Description	Min.	Typ.	Max.	Unit
$t_1$	Output Period	Clock output range, 5V operation	10 [100 MHz]		2000 [500 KHz]	ns
$t_1$	Output Period	Clock output range, 3.3V operation	12.5 [80 MHz]		2000 [500 KHz]	ns
$t_{1A}$	Clock Jitter <sup>[9]</sup>	Peak-to-peak period jitter, % of clock period ( $f_{OUT} \leq 4$ MHz)		<0.5	1	%
$t_{1B}$	Clock Jitter <sup>[9]</sup>	Peak-to-peak period jitter (4 MHz $\leq f_{OUT} \leq 16$ MHz)		<0.7	1	ns
$t_{1C}$	Clock Jitter <sup>[9]</sup>	Peak-to-peak period jitter (16 MHz $< f_{OUT} \leq 50$ MHz)		<400	500	ps
$t_{1D}$	Clock Jitter <sup>[9]</sup>	Peak-to-peak period jitter ( $f_{OUT} > 50$ MHz)		<250	350	ps
	Output Duty Cycle <sup>[10]</sup>	Duty cycle for outputs, defined as $t_2 \div t_1$ <sup>[11]</sup> $f_{OUT} > 66.67$ MHz	40%	50%	60%	
		Duty cycle for outputs, defined as $t_2 \div t_1$ <sup>[11]</sup> $f_{OUT} \leq 66.67$ MHz	45%	50%	55%	
$t_3$	Rise time	Output clock rise time <sup>[12]</sup> at $C_L=25$ pF (15 pF at 3.3V operation)		3	5	ns
$t_4$	Fall time	Output clock fall time <sup>[12]</sup> at $C_L=25$ pF (15 pF at 3.3V operation)		2.5	4	ns
$t_5$	Frequency Slew Rate	Rate of change of frequency of CLKA	1	5	40	MHz/ ms
$t_6$	Power Up Stabilization Time	Output clock stable time after power up		< 25	50	ms

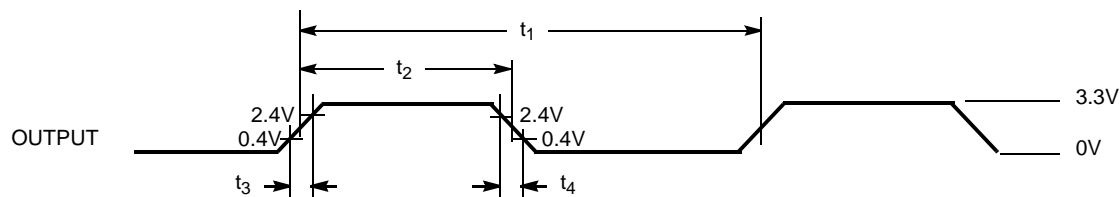
**Switching Waveforms**
**All Outputs Duty Cycle and Rise/Fall Time**

**Notes:**

8. Guaranteed by design, not 100% tested.
9. Jitter varies with configuration. All standard configurations sample tested at the factory conform to this limit. For more information on jitter, please refer to the application note: "Jitter in PLL-Based Systems."
10. Reference Output duty cycle depends on XTALIN duty cycle.
11. Measured at 1.4V.
12. Measured between 0.4V and 2.4V.

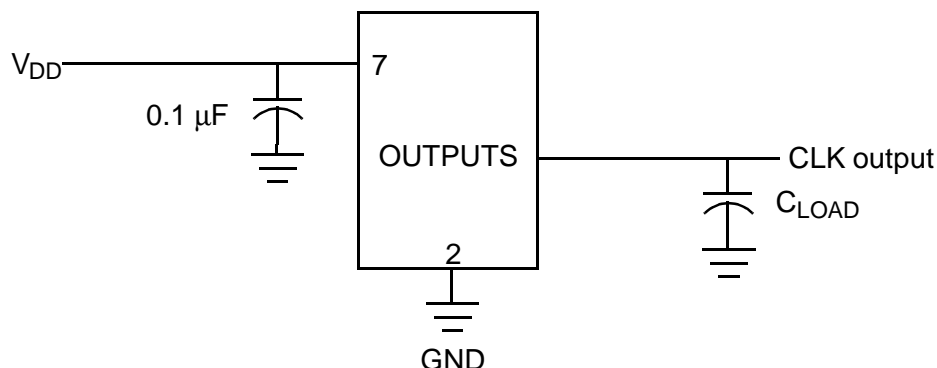
### Test Circuit



### Customer Configuration Request Procedure

The CY2081 is programmed at the wafer level, and is therefore only available as a factory programmed device. There is no field programming for the CY2081.

For CY2081 programmed configurations, design opportunities must be 50 Ku per year in production. If the design opportunity does not meet the factory minimums, the design can be implemented using the CY2292 (3-PLLs, 16-SOIC, field programmable), or the CY22381 (3-PLLs, 8-SOIC, field programmable).

For factory programmed samples, all requests must be submitted to your local Cypress FAE or sales representative. The method to use to request factory configurations is:

Use CyClocks software. This software automatically calculates the output frequencies that can be generated by the CY2081 and provides a printout of final pinout. Output frequencies requested will be matched as closely as the internal PLL divider and multiplier options allow. This printout and the design entry file produced by CyClocks (*<filename>.ENT*) can be submitted (in electronic format) to your local FAE or sales representative. CyClocks software is available free of charge from the Cypress website (<http://www.cypress.com>) or from your local FAE or sales representative.

Once the custom request has been processed you will receive a part number with a three-digit extension (e.g., CY2081SC-357) specific to the frequencies and pinout of your device. This will be the part number used for samples requests and production orders.

### Ordering Information

Ordering Code	Package Name	Package Type	Operating Range
CY2081SC-XXX	S8	8-Pin (150-Mil) SOIC	5.0V, Commercial <sup>[13]</sup>
CY2081SL-XXX	S8	8-Pin (150-Mil) SOIC	3.3V, Commercial <sup>[13]</sup>

**Note:**

13. 0°C to +70°C

CyClocks is a trademark of Cypress Semiconductor Corporation.

Package Diagram

8-Lead (150-Mil) SOIC S8

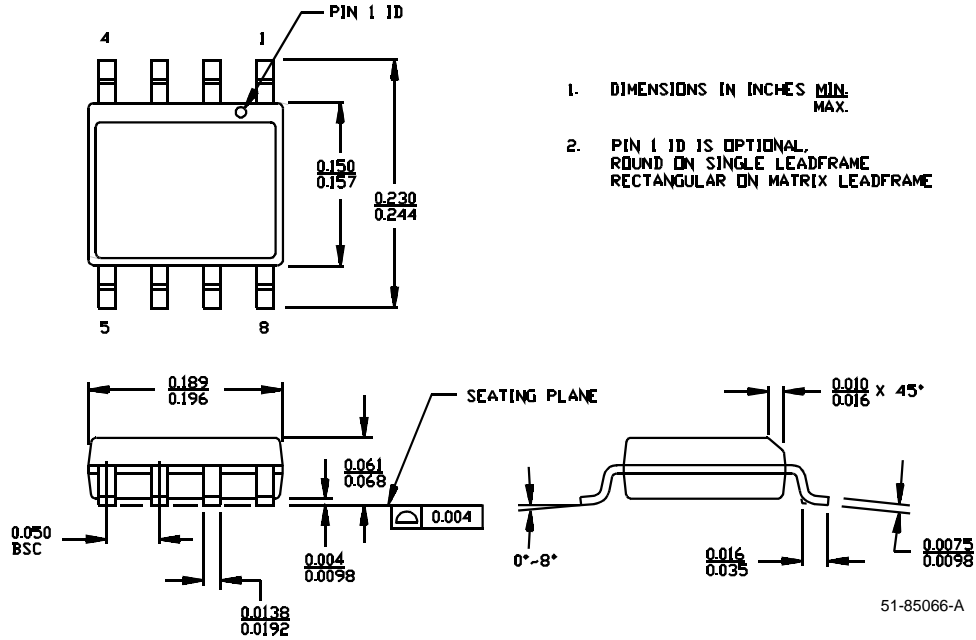

**Document Title: CY2081 Three-PLL General Purpose EPROM-Programmable Clock Generator**  
**Document Number: 38-07136**

<b>REV.</b>	<b>ECN NO.</b>	<b>Issue Date</b>	<b>Orig. of Change</b>	<b>Description of Change</b>
**	110245	10/28/01	SZV	Change from Spec number: 38-00463 to 38-07136