



CP2120 EVALUATION KIT USER'S GUIDE

1. Kit Contents

The CP2120 Evaluation Kit contains a CP2120 evaluation board and a power supply. The following supporting documents can be downloaded from www.silabs.com:

- CP2120 Data Sheet
- AN311: CP2120 Porting Guide

2. CP2120 Hardware Interface

The evaluation board is connected to a SPI master and to SMBus devices as shown in Figure 1.

1. Connect the SPI Master's SPI bus lines to the CP2120. If The CP2120 is the only SPI slave device on the SPI bus, then the CS pin can be tied low.
2. Connect the CP2120's INT pin to a port pin of the SPI Master.
3. Connect the CP2120 to SMBus devices through the SMBus lines.

Please refer to "4. Evaluation Board" on page 2 for more information about these steps.

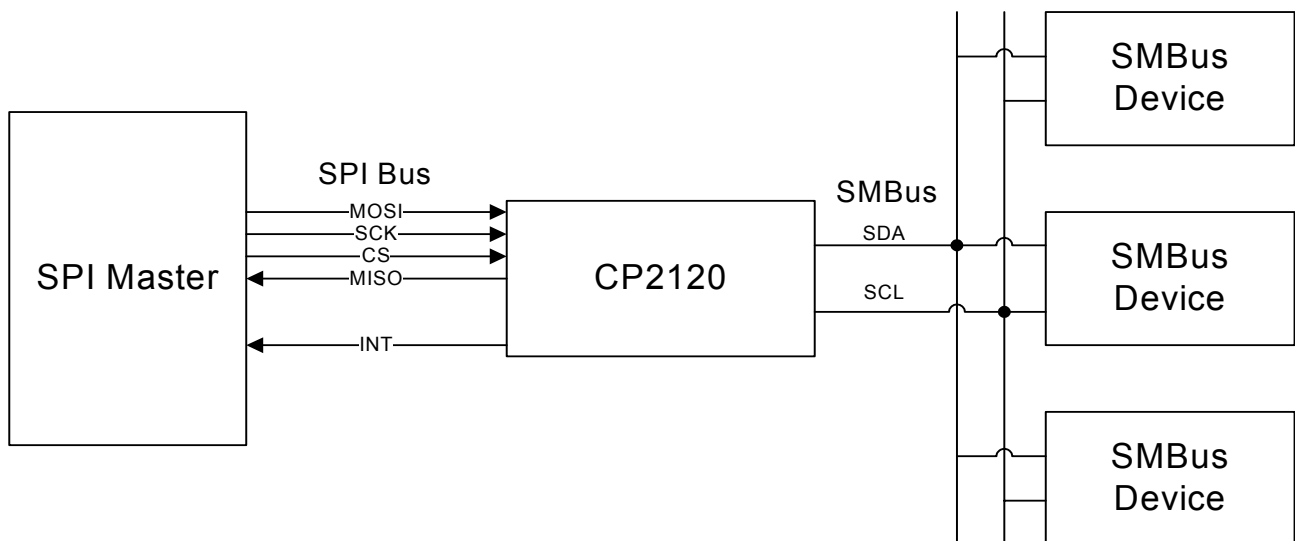

Figure 1. System Connections

3. CP2120 Operation

Once connected as shown in Figure 1, the SPI Master issues commands to the CP2120 across the SPI bus. The CP2120 responds to commands by initiating an SMBus transfer with SMBus slave devices, reading from or writing to internal registers, or interfacing with general purpose input/output (I/O) port pins. When an SMBus transaction completes, the CP2120 pulls the INT pin low, which signals the SPI Master that the command has been processed.

4. Evaluation Board

The CP2120 evaluation board comes with a CP2120 device pre-installed for system evaluation and development. Numerous I/O connections are provided to facilitate prototyping using the evaluation board. Refer to Figure 2 for the locations of the various I/O connectors.

- J1 Power Connector
- J2 SPI Master Interface
- J3 SMBus Interface
- J4 MISO-MOSI Connector
- J6 SMBus SDA Pullup Connector
- J7 SMBus SCL Pullup Connector
- J9 LED Connector
- J10 General Purpose I/O Interface

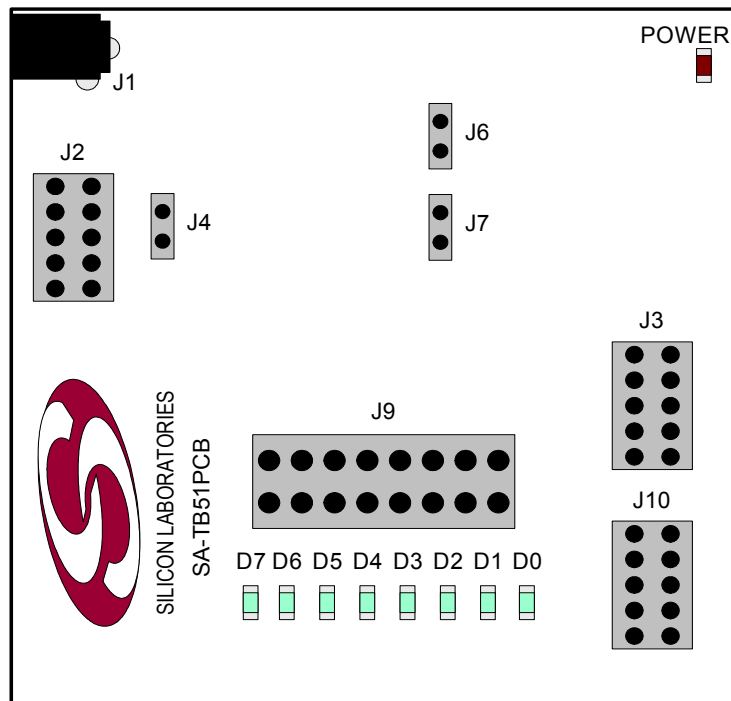

Figure 2. CP2120 Evaluation Board

4.1. J2—SPI Master Interface

Connector J2 provides the SPI Master access to the CP2120 SPI, control, and reset lines. Table 1 shows the pinout of the J2 header.

Table 1. Pinout for J2

| | |
|--------|--------------|
| Pin 1 | SPI Bus—SCLK |
| Pin 2 | SPI Bus—MISO |
| Pin 3 | SPI Bus—MOSI |
| Pin 4 | SPI Bus—CS |
| Pin 5 | INT |
| Pin 6 | Not Used |
| Pin 7 | RST |
| Pin 8 | GND |
| Pin 9 | Not Used |
| Pin 10 | Not Used |

4.2. J3—SMBus Interface

Connector J3 provides the CP2120 access to the SMBus. Table 2 shows the pinout of the J3 header.

Note: All pins labeled SCL are tied together, and all pins labeled SDA are tied together. Multiple connections to SCL and SDA signals are provided to allow multiple devices to connect to the evaluation board.

Table 2. Pinout for J3

| | |
|--------|-----------|
| Pin 1 | SMBus—SCL |
| Pin 2 | SMBus—SDA |
| Pin 3 | SMBus—SCL |
| Pin 4 | SMBus—SDA |
| Pin 5 | SMBus—SCL |
| Pin 6 | SMBus—SDA |
| Pin 7 | SMBus—SCL |
| Pin 8 | SMBus—SDA |
| Pin 9 | GND |
| Pin 10 | GND |

4.3. J4—SPI MISO/MOSI Connector

Some SPI master systems tie together the MISO and MOSI SPI data lines. The CP2120 evaluation board allows developers to connect these two signals through a resistor by placing a header on J4.

Note: When operating the SPI bus with a header on J4, only drive the MOSI pin whenever data is being transmitted to the CP2120. When the SPI bus is idle, or when the CP2120 is transmitting data, the SPI master must set its MOSI pin into an open-drain state to avoid port pin contention.

4.4. J6 and J7—SMBus Pullup Connectors

Connectors J6 and J7 give developers the option of adding pullup resistors to the SMBus's SDA and SCL lines. Removing shorting blocks from these headers disconnects the pullups from the SMBus lines.

Note: The SMBus lines need pullups to V_{DD} in order to function properly. If the headers are removed from J6 and J7, remember to add pullups to V_{DD} elsewhere on the SMBus.

4.5. J9—LED Connector

Connector J9 allows the CP2120's General Purpose I/O pins to be connected to the array of LEDs on the evaluation board. Once a header has been placed connecting a pin on the side closest to the CP2120 to its corresponding pin on the side of the jumper closest to the LEDs. To use one of the LEDs, place a shorting block on the J9 pin closest to the LED, connecting the corresponding J9 pin on the side of the connector closer to the CP2120. See Figure 3 for an example of this connection. Writing a 0 to the connected general purpose I/O pin will turn on the LED, and writing a 1 to that pin will turn off the LED.

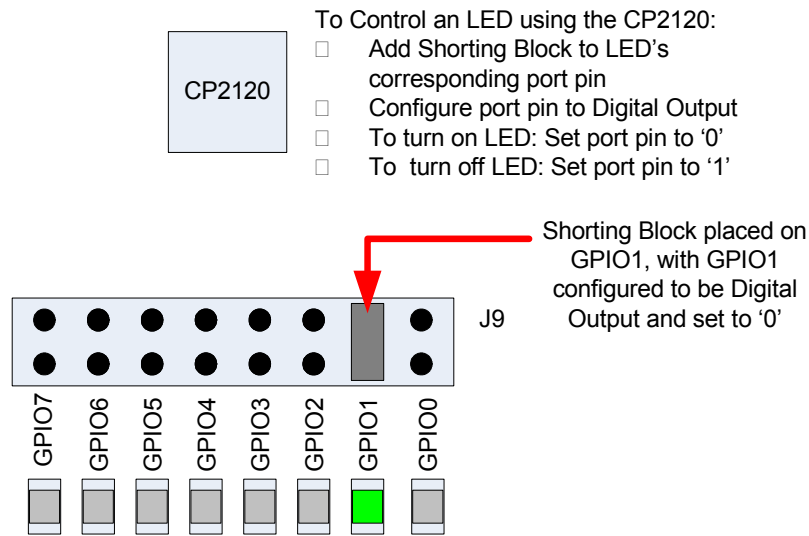

Figure 3. Controlling the LEDs

4.6. J10—General Purpose I/O Interface

Connector J10 enables off-board access to the CP2120's eight general purpose I/O pins, as well as the Edge-Triggered Interrupt Source pin. Table 3 shows the pinout for this header.

Table 3. Pinout for J10

| | |
|--------|---------------------------------|
| Pin 1 | GPIO Pin 0 |
| Pin 2 | GPIO Pin 1 |
| Pin 3 | GPIO Pin 2 |
| Pin 4 | GPIO Pin 3 |
| Pin 5 | GPIO Pin 4 |
| Pin 6 | GPIO Pin 5 |
| Pin 7 | GPIO Pin 6 |
| Pin 8 | GPIO Pin 7 |
| Pin 9 | Edge Triggered Interrupt Source |
| Pin 10 | GND |

5. Schematic

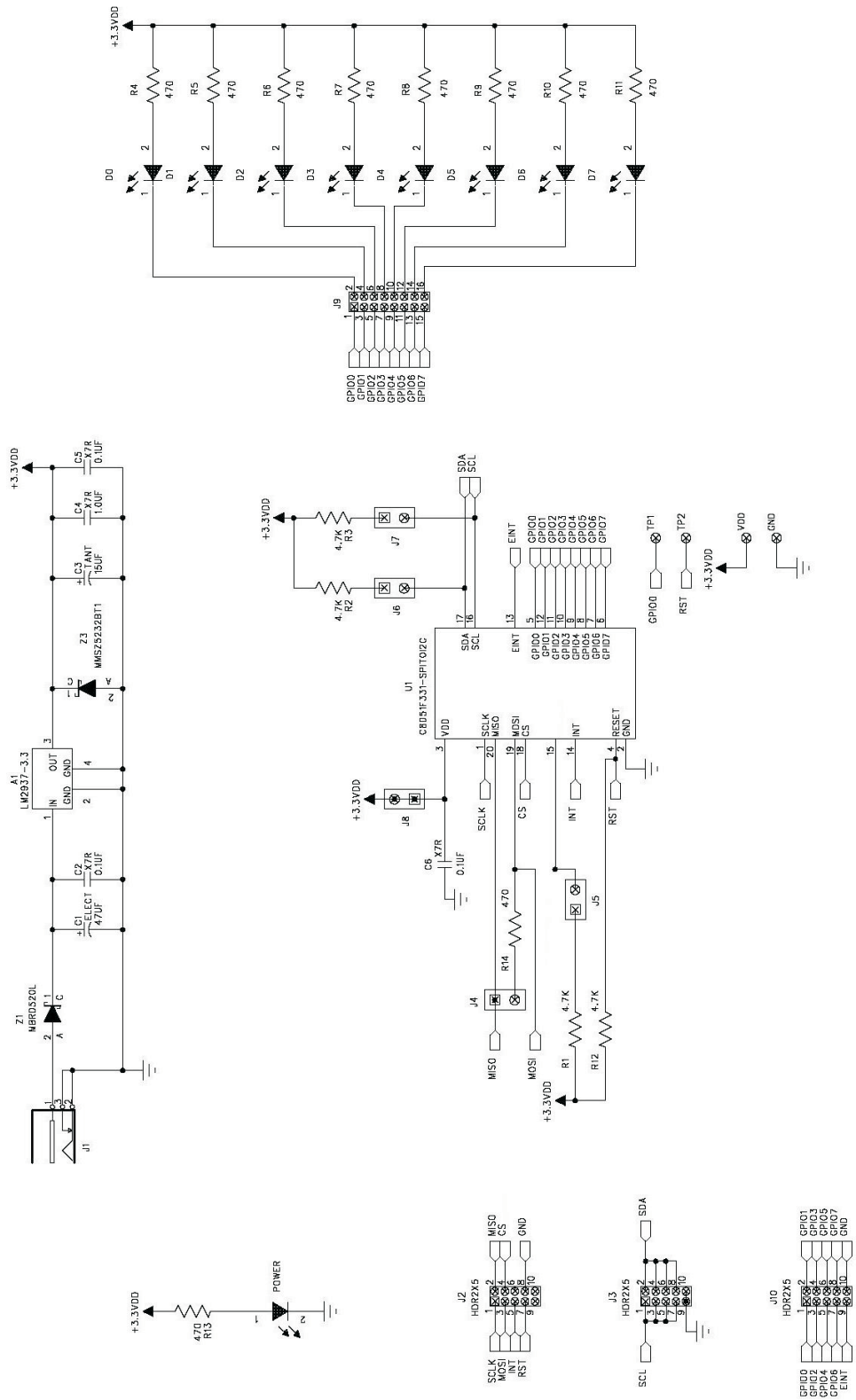

NOTES:

CONTACT INFORMATION

Silicon Laboratories Inc.
400 West Cesar Chavez
Austin, TX 78701
Tel: 1+(512) 416-8500
Fax: 1+(512) 416-9669
Toll Free: 1+(877) 444-3032
Email: MCUinfo@silabs.com
Internet: www.silabs.com

The information in this document is believed to be accurate in all respects at the time of publication but is subject to change without notice. Silicon Laboratories assumes no responsibility for errors and omissions, and disclaims responsibility for any consequences resulting from the use of information included herein. Additionally, Silicon Laboratories assumes no responsibility for the functioning of undescribed features or parameters. Silicon Laboratories reserves the right to make changes without further notice. Silicon Laboratories makes no warranty, representation or guarantee regarding the suitability of its products for any particular purpose, nor does Silicon Laboratories assume any liability arising out of the application or use of any product or circuit, and specifically disclaims any and all liability, including without limitation consequential or incidental damages. Silicon Laboratories products are not designed, intended, or authorized for use in applications intended to support or sustain life, or for any other application in which the failure of the Silicon Laboratories product could create a situation where personal injury or death may occur. Should Buyer purchase or use Silicon Laboratories products for any such unintended or unauthorized application, Buyer shall indemnify and hold Silicon Laboratories harmless against all claims and damages.

Silicon Laboratories and Silicon Labs are trademarks of Silicon Laboratories Inc.

Other products or brandnames mentioned herein are trademarks or registered trademarks of their respective holders.