

Four Output Clock Generator/Jitter Cleaner With Integrated Dual VCOs

FEATURES

- Frequency Synthesizer With PLL/VCO and Partially Integrated Loop Filter
- Fully Configurable Outputs Including Frequency and Output Format
- Smart Input Multiplexer Automatically Switches Between one of two Reference Inputs.
- Multiple Operational Modes Include Clock Generation via Crystal, SERDES Startup Mode, Jitter Cleaning, and Oscillator Based Holdover Mode.
- Integrated EEPROM Determines Device Configuration at Power-up.
- Excellent Jitter Performance
- Integrated Frequency Synthesizer Including PLL, Multiple VCOs, and Loop Filter:
 - Full Programmability Facilitates Phase Noise Performance Optimization Enabling Jitter Cleaner Mode
 - Programmable Charge Pump Gain and Loop Filter Settings
 - Unique Dual-VCO Architecture Supports a Wide Tuning Range 1.750 GHz – 2.356 GHz.
- Universal Output Blocks Support up to 2 Differential, 4 Single-Ended, or Combinations of Differential or Single-Ended:
 - 0.5 ps RMS (10 kHz to 20 MHz) Output Jitter Performance
 - Low Output Phase Noise: –130 dBc/Hz at 1 MHz offset, $F_c = 491.52$ MHz
 - Output Frequency Ranges From 10.94 MHz to 1.175 GHz in Synthesizer Mode
 - LVPECL, LVDS and LVCMOS
 - Independent Output Dividers Support Divide Ratios for 1,2,3,4,5,8,10,12,16,20,24 and 32.
- Flexible Inputs With Innovative Smart Multiplexer Feature:
 - Two Universal Differential Inputs Accept Frequencies from 1 MHz up to 500 MHz (LVPECL), 500 MHz (LVDS), or 250 MHz (LVCMOS).
 - One Auxiliary Input Accepts Single Ended Clock Source or Crystal. Auxiliary Input Accepts Crystals in the Range of 2MHz–42MHz or an LVCMOS Input up to 75MHz.
 - Clock Generator Mode Using Crystal Input
 - Smart Input Multiplexer can be Configured to Automatically Switch Between Highest Priority Clock Source Available Allowing for Fail-Safe Operation.
- Typical Power Consumption 750mW at 3.3V
- Integrated EEPROM Stores Default Settings; Therefore, the Device can Power up in a Known, Predefined State.
- Offered in QFN-32 Package
- ESD Protection Exceeds 2kV HBM
- Industrial Temperature Range –40°C to 85°C

APPLICATIONS

- Data Converter and Data Aggregation Clocking
- Wireless Infrastructure
- Switches and Routers
- Medical Electronics
- Military and Aerospace
- Industrial
- Clock Generation and Jitter Cleaning



Please be aware that an important notice concerning availability, standard warranty, and use in critical applications of Texas Instruments semiconductor products and disclaimers thereto appears at the end of this data sheet.



These devices have limited built-in ESD protection. The leads should be shorted together or the device placed in conductive foam during storage or handling to prevent electrostatic damage to the MOS gates.

DESCRIPTION

The CDCE62002 is a high performance clock generator featuring low output jitter, a high degree of configurability via a SPI interface, and programmable start up modes determined by on-chip EEPROM. Specifically tailored for clocking data converters and high-speed digital signals, the CDCE62002 achieves jitter performance under 0.5 ps RMS⁽¹⁾. It incorporates a synthesizer block with partially integrated loop filter, a clock distribution block including programmable output formats, and an input block featuring an innovative smart multiplexer. The clock distribution block includes two individually programmable outputs that can be configured to provide different combinations of output formats (LVPECL, LVDS, LVCMOS). Each output can also be programmed to a unique output frequency (ranging from 10.94 MHz to 1.175 GHz⁽²⁾). If Both outputs are configured in single-ended mode (e.g., LVCMOS), the CDCE62002 supports up to four outputs. The input block includes one universal differential inputs which support frequencies up to 500 MHz and an auxiliary single ended input that can be connected to a CMOS level clock or configured to connect to an external AT-Cut crystal via an on board oscillator block. The smart input multiplexer has two modes of operation, manual and automatic. In manual mode, the user selects the synthesizer reference via the SPI interface. In automatic mode, the input multiplexer will automatically select between the highest priority input clock available.

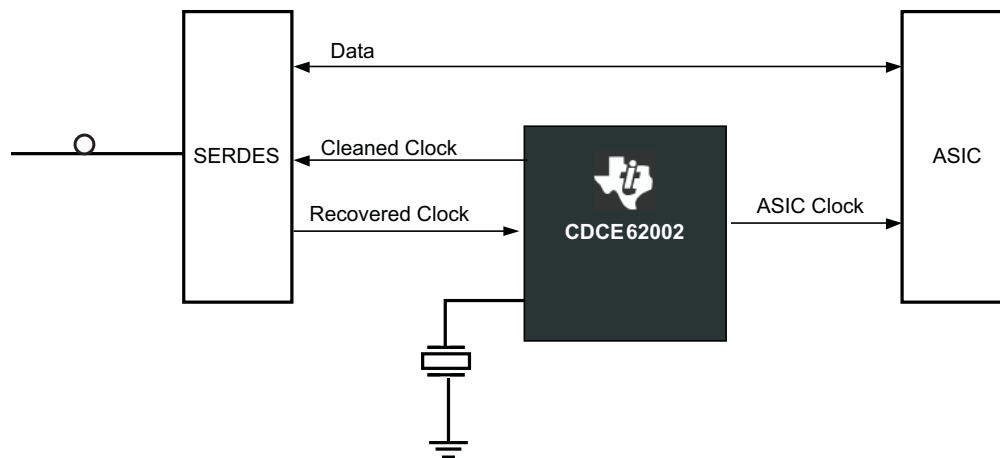

Figure 1. CDCE62002 Application Example

- (1) 10 kHz to 20 MHz integration bandwidth.
- (2) Frequency range depends on operational mode and output format selected.

DEVICE INFORMATION

PIN FUNCTIONS

Table 1. CDCE62002 Pin Functions⁽¹⁾

PIN		TYPE	DESCRIPTION
NAME	QFN		
VCC_OUT0 VCC_OUT1	9,12 13,16	Power	3.3V Supply for the Output Buffers. There is no internal connection between V _{CC} and AV _{CC} . It is recommended, that each V _{CC} uses its own supply filter.
VCC_PLLDIV	22	Power	3.3V Supply Power for the PLL circuitry.
VCC_PLLD	4	Power	3.3V Supply Power for the PLL circuitry.
VCC_PLLA	28	A. Power	3.3V Supply Power for the PLL circuitry.
VCC_VCO	24	A. Power	3.3V Supply Power for the VCO Circuitry.
VCC_IN	31	Power	3.3V Supply Power for Input Buffer Circuitry
VCC_AUX	1	A. Power	3.3V Supply Power for Crystal/Auxiliary Input Buffer Circuitry
GND_PLLDIV	21	Ground	Ground for PLL Divider circuitry. (short to GND)
GND	PAD	Ground	Ground is on Thermal PAD. See Layout recommendation
SPI_MISO	7	OD	3-state LVCMOS Output that is enabled when SPI_LE is asserted low. It is the serial Data Output to the SPI bus interface.
SPI_LE	18	I	LVCMOS input, control Latch Enable for Serial Programmable Interface. <i>Note: The SPI_LE signal has to be high in order for the EEPROM to load correctly on the Rising edge of PD.</i> The input has an internal 150-kΩ pull-up resistor
SPI_CLK	17	I	LVCMOS input, serial Control Clock Input for the SPI bus interface, with Hysteresis.
SPI_MOSI	8	I	LVCMOS input, Master Out Slave In as a serial Control Data Input to CDCE62002 for the SPI bus interface.
\overline{PD}	6	I	\overline{PD} or Power Down Pin is an active low pin and can be activated externally or via the corresponding Bit in SPI Register 2 In case of \overline{PD} is asserted, the Device shuts Down and after \overline{PD} goes high the EEPROM Loads into RAM and the VCO core re-starts calibration, PLL will try to relock and the Output dividers will get re-initiated. The LVPECL outputs are static low and high respectively and the LVCMOS outputs are all low or high if inverted. The input has an internal 150-kΩ pull-up resistor if left unconnected it will default to logic level "1". <i>Note: The SPI_LE signal has to be high in order for the EEPROM to load correctly into RAM on the Rising edge of PD.</i>
AUX_IN	2	I	Auxiliary Input is a Crystal input pin that connect to an internal oscillator circuitry. This input can also be driven by an LVCMOS signal. This input also serves as the External Feedback Input that feeds directly to the PFD.
REF+	29	I	Universal Input Buffer (LVPECL, LVDS, LVCMOS) positive input for the Reference Clock.
REF-	30	I	Universal Input Buffer (LVPECL, LVDS,) negative input for the Reference Clock. In case of LVCMOS signaling pull-down this pin.
PLL_LOCK	32	O	PLL Lock indicator
TESTSYNC	19	I	Test Point for Use for TI Internal SYNC Testing.
REG_CAP1	5	Analog	Capacitor for the internal Regulator. Connect to a 10 μF Capacitor (Y5V)
REG_CAP2	27	Analog	Capacitor for the internal Regulator. Connect to a 10 μF Capacitor (Y5V)
REG_CAP3	20	Analog	Capacitor for the internal Regulator. Connect to a 10 μF Capacitor (Y5V)
REG_CAP4	23	Analog	Capacitor for the internal Regulator. Connect to a 10 μF Capacitor (Y5V)
VBB	3	Analog	Capacitor for the internal termination Voltage. Connect to a 1 μF Capacitor (Y5V)
EXT_LFP	25	Analog	External Loop Filter Input Positive
EXT_LFN	26	Analog	External Loop Filter Input Negative.
U0P:U0N U1P:U1N	11,10 15,14	O	The Main outputs of CDCE62002 are user definable and can be any combination of up to 2 LVPECL outputs, 2 LVDS outputs or up to 4 LVCMOS outputs. The outputs are selectable via SPI interface. The power-up setting is EEPROM configurable.

(1) NOTE: All VCC pins need to be connected for the device to operate properly.

FUNCTIONAL DESCRIPTION

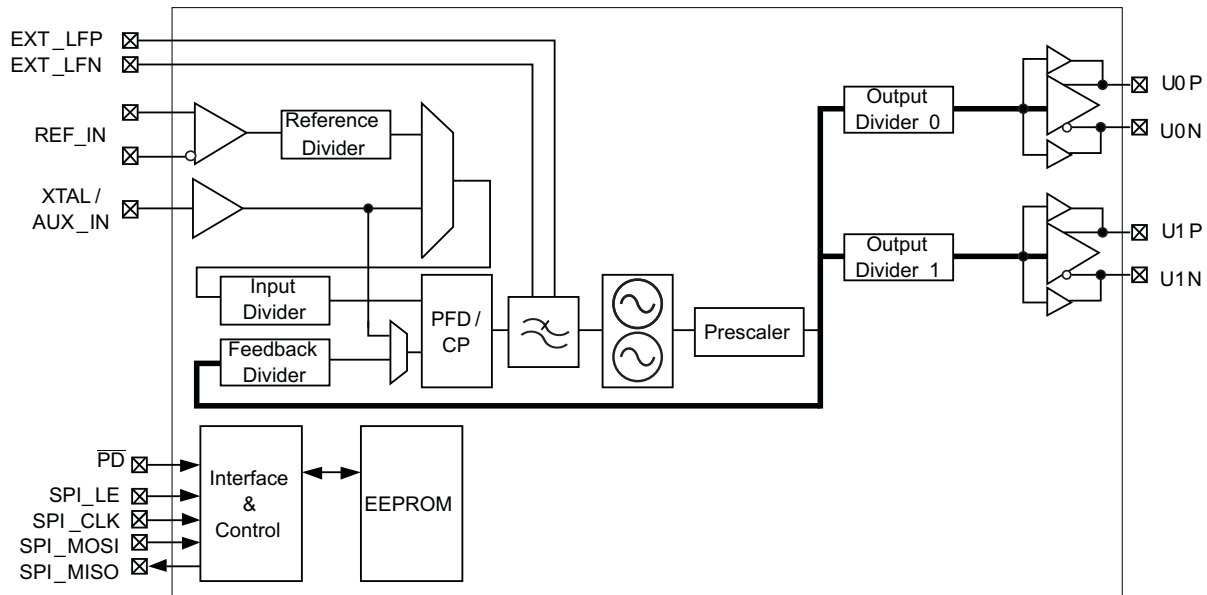

Figure 2. CDCE62002 Block Diagram

The CDCE62002 comprises of four primary blocks: the interface and control block, the input block, the output block, and the synthesizer block. In order to determine which settings are appropriate for any specific combination of input/output frequencies, a basic understanding of these blocks is required. The interface and control block determines the state of the CDCE62002 at power-up based on the contents of the on-board EEPROM. In addition to the EEPROM, the SPI port is available to configure the CDCE62002 by writing directly to the device registers after power-up. The input block selects which of the two input ports is available for use by the synthesizer block. The output block provides two separate clock channels that are fully programmable. The synthesizer block multiplies and filters the input clock selected by the input block.

NOTE:

This Section of the data sheet provides a high-level description of the features of the CDCE62002 for purpose of understanding its capabilities. For a complete description of device registers and I/O, refer to the Device Configuration Section.

Interface and Control Block

The CDCE62002 is a highly flexible and configurable architecture and as such contains a number of registers so that the user may specify device operation. The contents of nine 28-bit wide registers implemented in static RAM determine device configuration at all times. On power-up, the CDCE62002 copies the contents of the EEPROM into the RAM and the device begins operation based on the default configuration stored in the EEPROM. Systems that do not have a host system to communicate with the CDCE62002 use this method for device configuration. The CDCE62002 provides the ability to lock the EEPROM; enabling the designer to implement a fault tolerant design. After power-up, the host system may overwrite the contents of the RAM via the SPI (Serial Peripheral Interface) port. This enables the configuration and reconfiguration of the CDCE62002 during system operation. Finally, the device offers the ability to copy the contents of the RAM into EEPROM, if the EEPROM is unlocked.

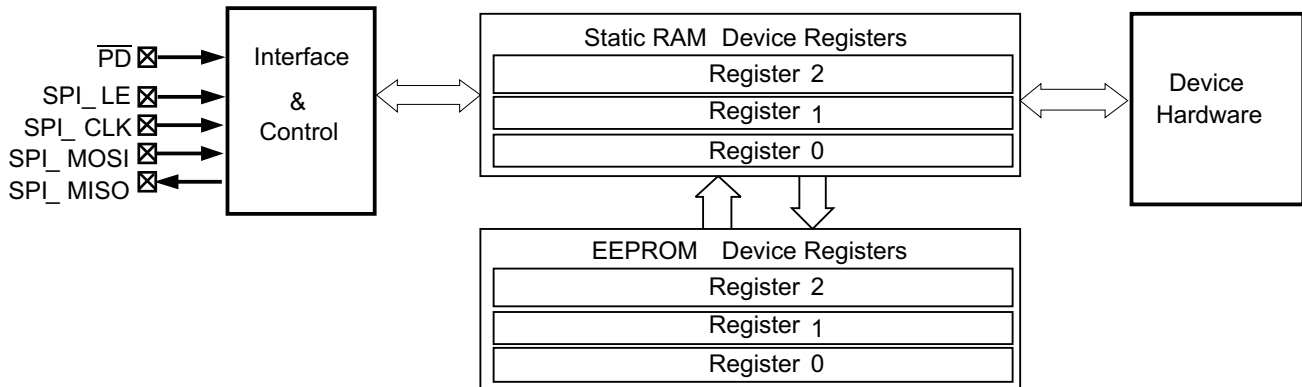

Figure 3. CDCE62002 Interface and Control Block

Input Block

The Input Block includes one Universal Input Buffer and an Auxiliary Input. The Input Block buffers the incoming signals and facilitates signal routing to the Internal Synthesizer Block via the smart multiplexer (called the Smart MUX). The CDCE62002 can divide the REF_IN signal via the dividers present on the inputs of the first stage of the Smart MUX.

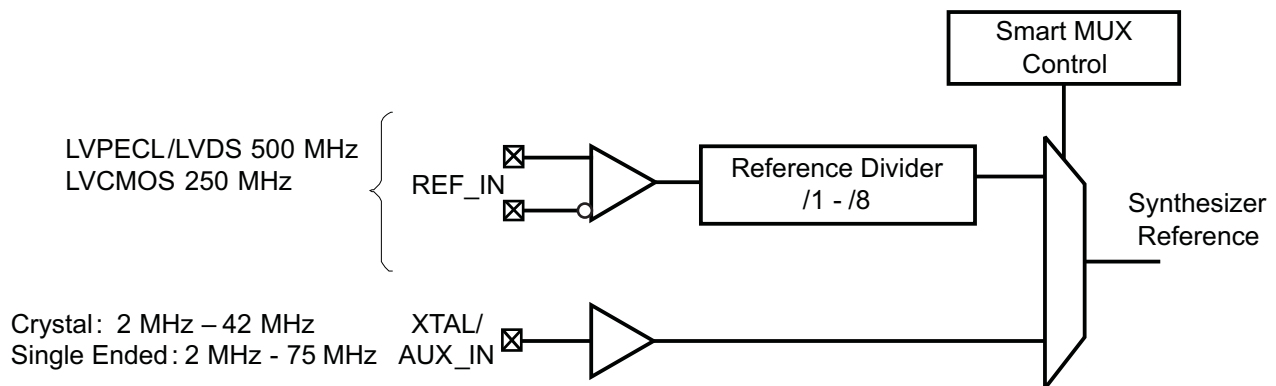

Figure 4. CDCE62002 Input Block

Synthesizer Block

Figure 5 presents a high-level overview of the Synthesizer Block on the CDCE62002. This block contains the Phase lock loop, internal loop filter and dual Voltage controlled oscillators. Only one VCO is selected at a time. The loop is closed after a Prescaler divider that feeds the output stage the feedback divider.

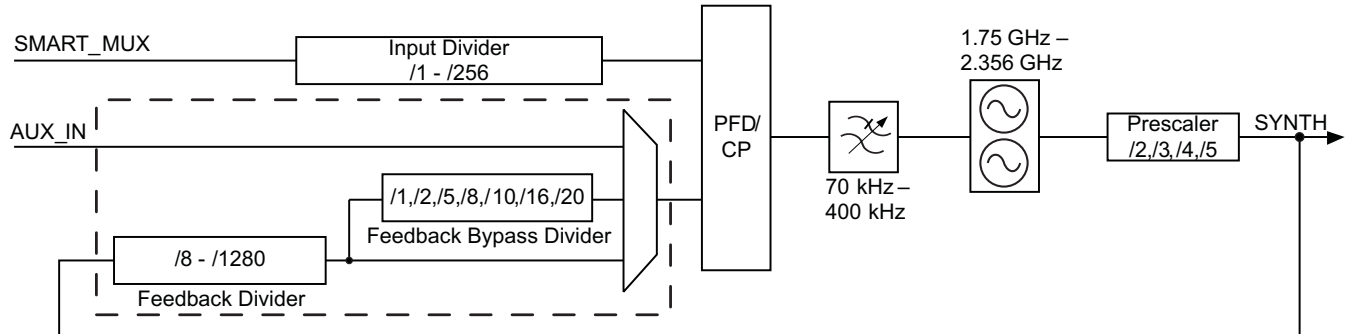

Figure 5. CDCE62002 Synthesizer Block

Output Block

Both identical output blocks incorporate a Clock Divider Module (CDM), and a universal output array buffer driver. If an individual clock output channel is not used, then the user should disable the CDM and Output Buffer for the unused channel to save device power. Each channel includes 4-bit in register “0” to control the divide ratio. The output divider supports divide ratios from divide by 1 (bypass the divider) 2,3,4,5,8,10,12,16,20,24 and 32.

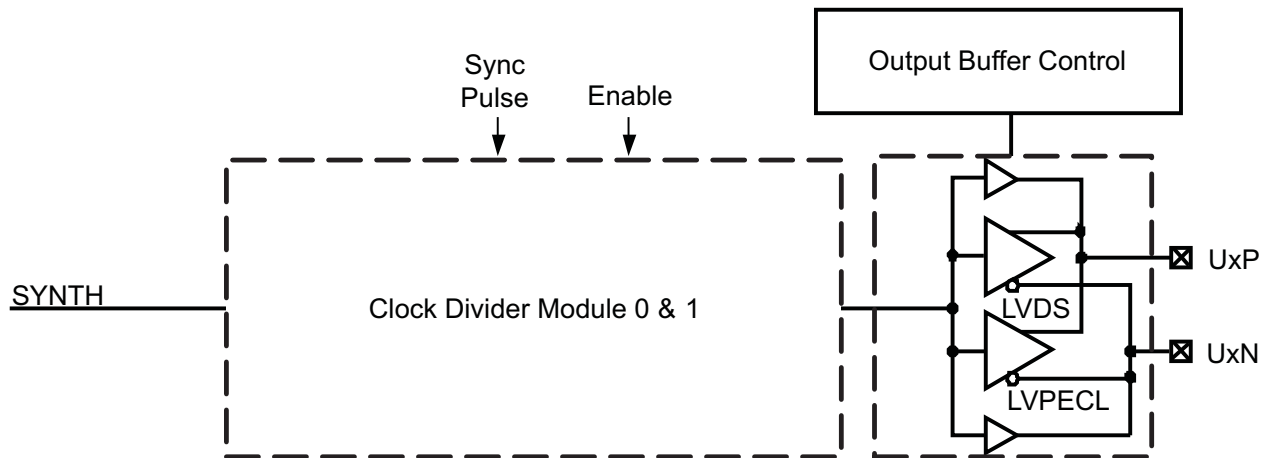

Figure 6. CDCE62002 Output Block

COMPUTING THE OUTPUT FREQUENCY

Figure 7 presents the block diagram of the CDCE62002 synthesizer highlighting the clock path for a single output. It also identifies the following regions containing dividers comprising the complete clock path:

- R: Is the Reference divider values.
- O: The output divider value (see Output Block for more details)
- I: The input divider value (see Synthesizer Block for more details)
- P: The Prescaler divider value (see Synthesizer Block of more details)
- F: The cumulative divider value of all dividers falling within the feedback divider (see Synthesizer Block for more details)

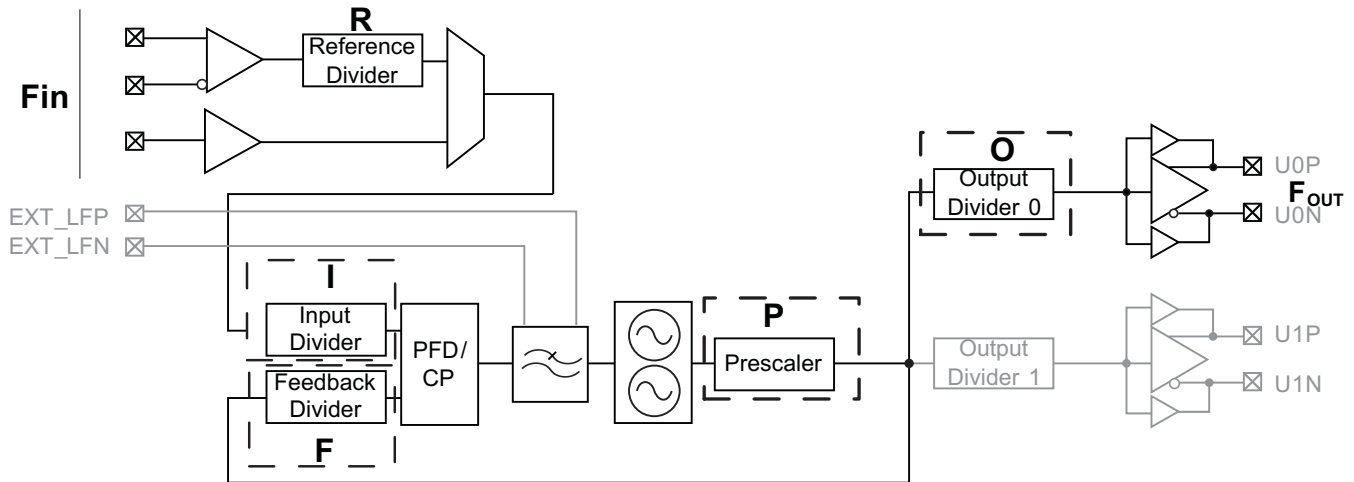

Figure 7. CDCE62002 Clock Path – Synthesizer

With respect to Figure 7, any output frequency generated by the CDCE62002 relates to the input frequency connected to the Synthesizer Block by the following equation:

$$F_{OUT} = F_{IN} \cdot \frac{F}{R \cdot I \cdot O} \quad (1)$$

Equation 1 holds true subject to the following constraints:

$$1.750\text{GHz} < O \cdot P \cdot F_{OUT} < 2.356\text{GHz} \quad (2)$$

And the comparison frequency F_{COMP} ,

$$40.0 \text{ kHz} \leq F_{COMP} \leq 40 \text{ MHz}$$

Where:

$$F_{COMP} = \frac{F_{IN}}{R \cdot I} \quad (3)$$

ABSOLUTE MAXIMUM RATINGS

over operating free-air temperature range (unless otherwise noted) ⁽¹⁾

	VALUE / UNIT
Supply voltage range VCC ⁽²⁾	–0.5 V to 4.6 V
Input voltage range, V _I ⁽³⁾	–0.5 V to VCC + 0.5 V
Output voltage range, V _O ⁽³⁾	–0.5 V to VCC + 0.5 V
Input Current (V _I < 0, V _I > VCC)	±20 mA
Output current for LVPECL/LVCMOS Outputs (0 < V _O < VCC)	±50 mA
Maximum junction temperature, T _J	125°C
Storage temperature range, T _{stg}	–65°C to 150°C

- (1) Stresses beyond those listed under *absolute maximum ratings* may cause permanent damage to the device. These are stress ratings only and functional operation of the device at these or any other conditions beyond those indicated under *recommended operating conditions* is not implied. Exposure to absolute–maximum–rated conditions for extended periods may affect device reliability.
- (2) All supply voltages have to be supplied simultaneously.
- (3) The input and output negative voltage ratings may be exceeded if the input and output clamp-current ratings are observed.

THERMAL CHARACTERISTICS

Package Thermal Resistance for QFN (RGZ) Package

Airflow (lfm)		θ _{JP} (°C/W)	θ _{JA} (°C/W)
0	JEDEC Compliant Board (3X3 VIAs on PAD)	1.13	35
200	JEDEC Compliant Board (3X3 VIAs on PAD)	1.13	28.3
400	JEDEC Compliant Board (3X3 VIAs on PAD)	1.13	27.2

PACKAGE

The CDCE62002 is packaged in a 32-Pin Lead Free “Green” Plastic Quad Flatpack Package with enhanced bottom thermal pad for heat dissipation. The Texas Instruments Package Designator is; RHB (S-PQFP-N32). Please refer to the Mechanical Data appendix at the end of this document for more information.

ELECTRICAL CHARACTERISTICS

recommended operating conditions for the CDCE62002 Device for under the specified Industrial temperature range of –40°C to 85°C

PARAMETER		TEST CONDITIONS	MIN	TYP ⁽¹⁾	MAX	UNIT
POWER SUPPLY						
Supply voltage, V _{CC_OUT} , V _{CC_PLLDIV} , V _{CC_PLLD} , V _{CC_IN+} , and V _{CC_AUX}			3	3.3	3.6	V
Analog Supply Voltage, VCC_PLLA, & VCC_VCO			3	3.3	3.6	V
P _{LVPECL}	REF at 30.72MHz Outputs are LVPECL	Output 1 = 491.52 MHz Output 2 = 245.76 MHz In case of LVCMOS Outputs (1) = 245.76MHz		850		mW
P _{LVDS}	REF at 30.72MHz Outputs are LVDS			750		mW
P _{LVCMOS}	REF at 30.72MHz Outputs are LVCMOS			800		mW
P _{OFF}	REF at 30.72MHz	Dividers and Outputs are disabled		450		mW
P _{PD}		Device is Powered Down		40		mW
DIFFERENTIAL INPUT MODE (REF_IN)						
Input amplitude, VINPP (V _{IN+} – V _{IN-})			0.1		1.3	V
Common-mode input voltage, VIC			1.0		V _{CC-03}	V
I _{IH}	Differential input current High (No internal Termination)	V _I = VCC, VCC = 3.6 V			20	μA
I _{IL}	Differential input current Low (No internal Termination)	V _I = 0 V, VCC = 3.6 V	–20			μA
Input Capacitance on REF_IN				3		pF
LVCMOS INPUT MODE (AUX_IN)						
V _{IL}	Low-level input voltage LVCMOS		0		0.3 VCC	V

- (1) All typical values are at VCC = 3.3 V, temperature = 25°C.

ELECTRICAL CHARACTERISTICS (continued)

 recommended operating conditions for the CDCE62002 Device for under the specified Industrial temperature range of -40°C to 85°C

PARAMETER		TEST CONDITIONS		MIN	TYP ⁽¹⁾	MAX	UNIT
V_{IH}	High-level input voltage LVCMOS			0.7 VCC		VCC	V
V_{IK}	LVCMOS input clamp voltage	$V_{CC} = 3\text{ V}, I_I = -18\text{ mA}$				-1.2	V
I_{IH}	LVCMOS input current	$V_I = V_{CC}, V_{CC} = 3.6\text{ V}$		300			μA
I_{IL}	LVCMOS input	$V_I = 0\text{ V}, V_{CC} = 3.6\text{ V}$		-10		10	μA
C_I	Input capacitance (LVCMOS signals)	$V_I = 0\text{ V}$ or VCC 8		8			pF
CRYSTAL INPUT SPECIFICATIONS							
Crystal Shunt Capacitance						10	pF
Equivalent Series Resistance (ESR)						50	Ω
LVCMOS INPUT MODE (SPI_CLK, SPI_MOSI, SPI_LE, PD, REF_IN)							
V_{IL}	Low-level input voltage LVCMOS			0		0.3 VCC	V
V_{IH}	High-level input voltage LVCMOS			0.7 VCC		VCC	V
V_{IK}	LVCMOS input clamp voltage	$V_{CC} = 3\text{ V}, I_I = -18\text{ mA}$				-1.2	V
I_{IH}	LVCMOS input current $V_I =$	$V_{CC}, V_{CC} = 3.6\text{ V}$				20	μA
I_{IL}	LVCMOS input (Except REF_IN)	$V_I = 0\text{ V}, V_{CC} = 3.6\text{ V}$		-10		-40	μA
I_{IL}	LVCMOS input (REF_IN)	$V_I = 0\text{ V}, V_{CC} = 3.6\text{ V}$		-10		10	μA
C_I	Input capacitance (LVCMOS signals)	$V_I = 0\text{ V}$ or VCC 3		3			pF
SPI OUTPUT (MISO) / PLL							
I_{OH}	High-level output current	$V_{CC} = 3.3\text{ V},$	$V_O = 1.65\text{ V}$	-30			mA
I_{OL}	Low-level output current	$V_{CC} = 3.3\text{ V},$	$V_O = 1.65\text{ V}$	33			mA
V_{OH}	High-level output voltage for LVCMOS outputs	$V_{CC} = 3\text{ V},$	$I_{OH} = -100\text{ }\mu\text{A}$	VCC-0.5			V
V_{OL}	Low-level output voltage for LVCMOS outputs	$V_{CC} = 3\text{ V},$	$I_{OH} = 100\text{ }\mu\text{A}$			0.3	V
C_O	Output capacitance o MISO	$V_{CC} = 3.3\text{ V}; V_O = 0\text{ V}$ or VCC		3			pF
I_{OZH}	3-state output current	$V_O = V_{CC}, V_O = 0\text{ V}$		5			μA
I_{OZL}				-5			μA
EEPROM							
EEcyc	Programming cycle of EEPROM			100	1000		Cycles
EEret	Data retention			10			Years
VBB (INPUT BUFFER INTERNAL TERMINATION VOLTAGE REFERENCE)							
V_{BB}	Input termination voltage	$I_{BB} = -0.2\text{ mA},$ Depending on the setting		1.2		1.9	V
INPUT BUFFERS INTERNAL TERMINATION RESISTORS (REF_IN)							
Termination resistance		Single ended		5			k Ω
PHASE DETECTOR							
f_{CPmax}	Charge pump frequency			0.04		40	MHz

ELECTRICAL CHARACTERISTICS (Continued)

recommended operating conditions for the CDCE62002 Device for under the specified Industrial temperature range of –40°C to 85°C

PARAMETER		TEST CONDITIONS		MIN	TYP ⁽¹⁾	MAX	UNIT
LVC MOS							
f_{clk}	Output frequency, see Figure below	Load = 5 pF to GND				250	MHz
V_{OH}	High-level output voltage for LVC MOS outputs	$V_{CC} = \text{min to max}$	$I_{OH} = -100 \mu\text{A}$	$V_{CC}-0.5$			V
V_{OL}	Low-level output voltage for LVC MOS outputs	$V_{CC} = \text{min to max}$	$I_{OL} = 100 \mu\text{A}$			0.3	V
I_{OH}	High-level output current	$V_{CC} = 3.3 \text{ V}$	$V_O = 1.65 \text{ V}$		-30		mA
I_{OL}	Low-level output current	$V_{CC} = 3.3 \text{ V}$	$V_O = 1.65 \text{ V}$		33		mA
t_{sko}	Skew, output to output For Y0 to Y1	Both Outputs set at 122.88 MHz, Reference = 30.72 MHz			75		ps
C_O	Output capacitance on Y0 to Y1	$V_{CC} = 3.3 \text{ V}; V_O = 0 \text{ V or } V_{CC}$			5		pF
I_{OZH}	Tristate LVC MOS output current	$V_O = V_{CC}$			5		μA
I_{OZL}	Tristate LVC MOS output current	$V_O = 0 \text{ V}$			-5		μA
I_{OPDH}	Power Down output current	$V_O = V_{CC}$				25	μA
I_{OPDL}	Power Down output current	$V_O = 0 \text{ V}$				5	μA
Duty cycle	LVC MOS			45%		55%	
$t_{slew-rate}$	Output rise/fall slew rate			3.6	5.2		V/ns

(1) All typical values are at $V_{CC} = 3.3 \text{ V}$, temperature = 25°C.

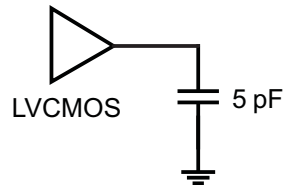

ELECTRICAL CHARACTERISTICS (Continued)

recommended operating conditions for the CDCE62002 Device for under the specified Industrial temperature range of -40°C to 85°C

PARAMETER		TEST CONDITIONS	MIN	TYP ⁽¹⁾	MAX	UNIT
LVDS OUTPUT						
f_{clk}	Output frequency	Configuration Load (see Figure below)	0		800	MHz
$ V_{\text{OD}} $	Differential output voltage	$R_L = 100\ \Omega$	270		550	mV
ΔV_{OD}	LVDS VOD Magnitude Change				50	mV
V_{OS}	Offset Voltage	-40°C to 85°C		1.24		V
ΔV_{OS}	VOS Magnitude Change			40		mV
	Short Circuit $V_{\text{out+}}$ to Ground	$V_{\text{OUT}} = 0$			27	mA
	Short Circuit $V_{\text{out-}}$ to Ground	$V_{\text{OUT}} = 0$			27	mA
$t_{\text{sk(o)}}$	Skew, output to output For Y0 to Y1	Both Outputs set at 122.88 MHz Reference = 30.72 MHz		10		ps
C_{O}	Output capacitance on Y0 to Y1	$V_{\text{CC}} = 3.3\ \text{V}$; $V_{\text{O}} = 0\ \text{V}$ or V_{CC}		5		pF
I_{OPDH}	Power Down output current	$V_{\text{O}} = V_{\text{CC}}$			25	μA
I_{OPDL}	Power Down output current	$V_{\text{O}} = 0\ \text{V}$			5	μA
	Duty Cycle		45%		55%	
t_r / t_f	Rise and fall time	20% to 80% of V_{outpp}	110	160	190	ps
LVCMOS-TO-LVDS						
$t_{\text{skP_C}}$	Output skew between LVCMOS and LVDS outputs	$V_{\text{CC}}/2$ to Crosspoint	1.4	1.7	2.0	ns

(1) All typical values are at $V_{\text{CC}} = 3.3\ \text{V}$, temperature = 25°C .

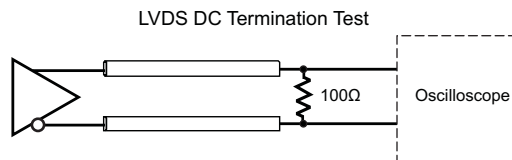

ELECTRICAL CHARACTERISTICS (Continued)

recommended operating conditions for the CDCE62002 Device for under the specified Industrial temperature range of –40°C to 85°C

PARAMETER	TEST CONDITIONS	MIN	TYP ⁽¹⁾	MAX	UNIT		
LVPECL OUTPUT							
f_{clk}	Output frequency,	Configuration Load (see Figure below)		0	1175	MHz	
V_{OH}	LVPECL high-level output voltage	Load		$V_{CC} - 1.1$	$V_{CC} - 0.88$	V	
V_{OL}	LVPECL low-level output voltage	Load		$V_{CC} - 2.02$	$V_{CC} - 1.48$	V	
$ V_{OD} $	Differential output voltage			510	870	mV	
t_{sko}	Skew, output to output For Y0 to Y1	Both Outputs set at 122.88 MHz			15	ps	
C_O	Output capacitance on Y0 to Y1	$V_{CC} = 3.3\text{ V}; V_O = 0\text{ V or }V_{CC}$			5	pF	
I_{OPDH}	Power Down output current	$V_O = V_{CC}$			25	μA	
I_{OPDL}	Power Down output current	$V_O = 0\text{ V}$			5	μA	
	Duty Cycle			45%	55%		
t_r / t_f	Rise and fall time	20% to 80% of V_{outpp}		55	75	735	ps
LVDS-TO- LVPECL							
t_{skP_C}	Output skew between LVDS and LVPECL outputs	Crosspoint to Crosspoint		130	200	280	ps
LVC MOS-TO- LVPECL							
t_{skP_C}	Output skew between LVC MOS and LVPECL outputs	$V_{CC}/2$ to Crosspoint		1.6	1.8	2.2	ns
LVPECL HI-PERFORMANCE OUTPUT							
V_{OH}	LVPECL high-level output voltage	Load		$V_{CC} - 1.11$	$V_{CC} - 0.91$	V	
V_{OL}	LVPECL low-level output voltage	Load		$V_{CC} - 2.06$	$V_{CC} - 1.84$	V	
$ V_{OD} $	Differential output voltage			670	950	mV	
t_r / t_f	Rise and fall time	20% to 80% of V_{outpp}		55	75	135	ps

(1) All typical values are at $V_{CC} = 3.3\text{ V}$, temperature = 25°C.

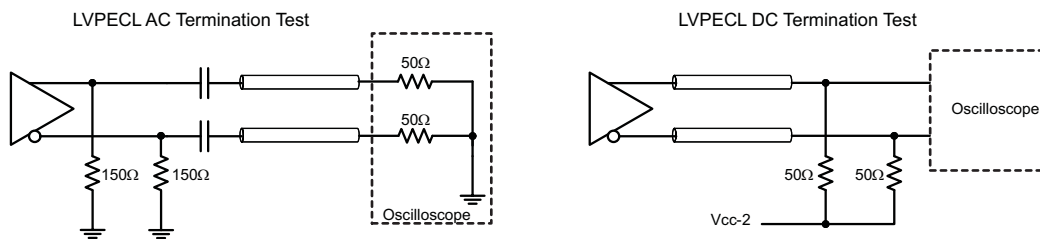

**LVPECL OUTPUT VOLTAGE SWING
vs
FREQUENCY**

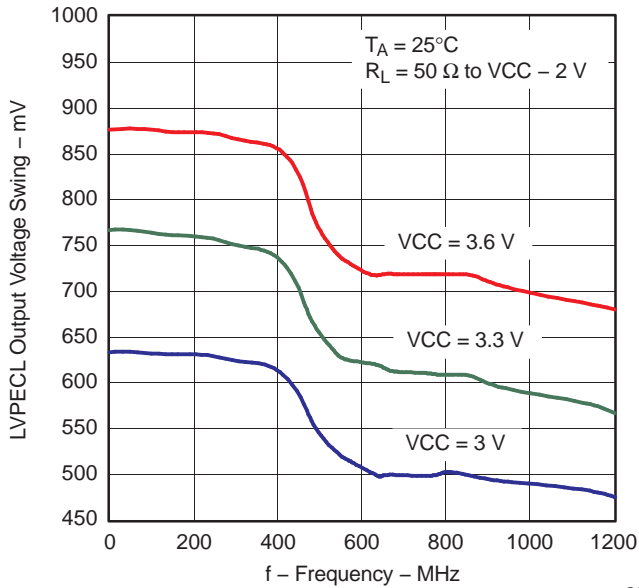

Figure 8.

**HIGH-PERFORMANCE LVPECL
OUTPUT VOLTAGE SWING
vs
FREQUENCY**

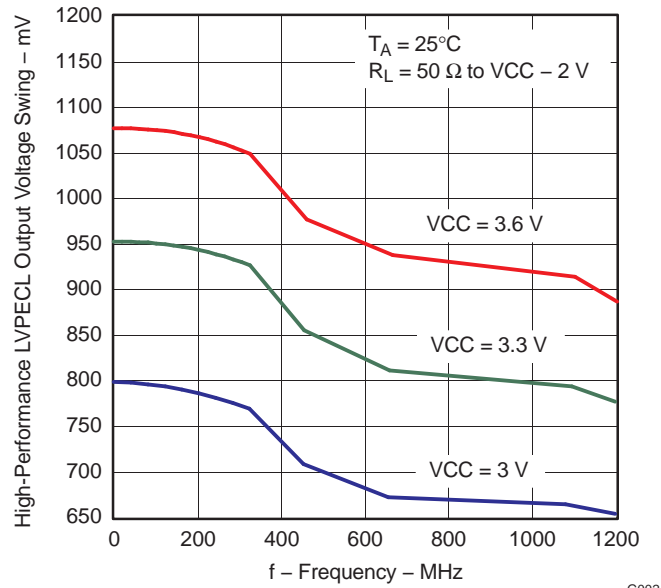

Figure 9.

**LVDS OUTPUT VOLTAGE SWING
vs
FREQUENCY**

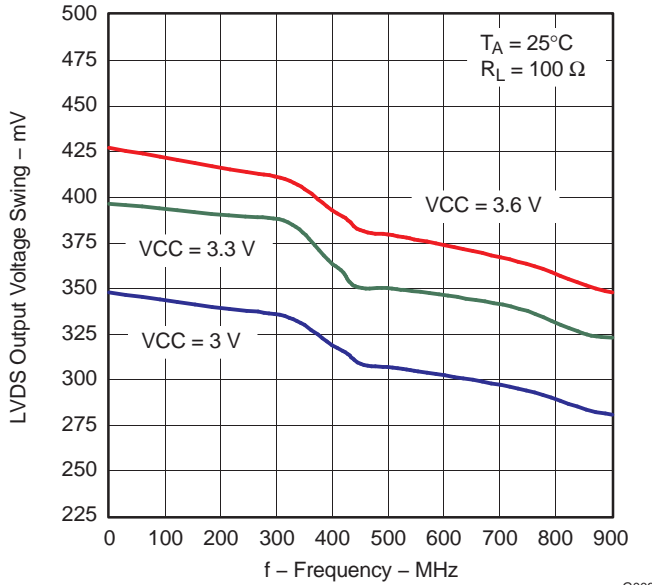

Figure 10.

**LVC MOS OUTPUT VOLTAGE SWING
vs
FREQUENCY**

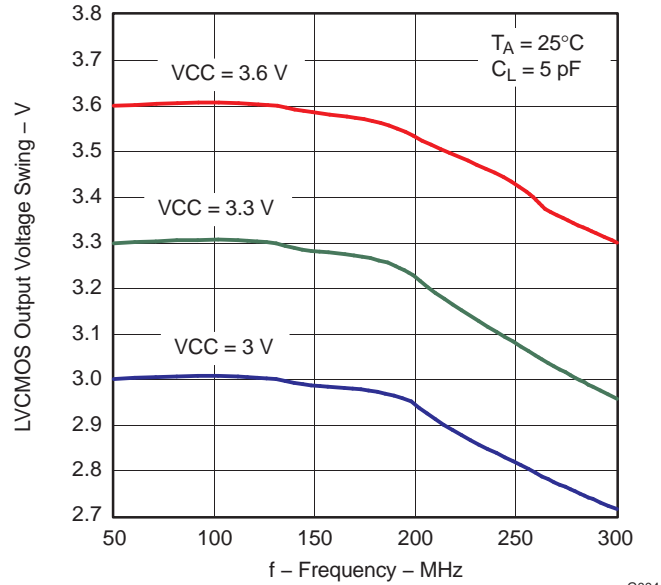

Figure 11.

TIMING REQUIREMENTS

over recommended ranges of supply voltage, load and operating free-air temperature range (unless otherwise noted)

PARAMETER		MIN	TYP	MAX	UNIT
REF_IN REQUIREMENTS					
$f_{REF-Diff\ IN-DIV}$	Maximum clock frequency applied to reference divider when (Register 0 Bit 9 = 1) (Reg 0 RAM bit 9 = 1)			500	MHz
$f_{REF-Diff\ REF_DIV}$	Maximum clock frequency applied to reference divider when (Register 0 Bit 9 = 0) (Reg 0 RAM bit 9 = 0)			250	MHz
$f_{REF-Single}$	For Single ended Inputs (LVCMOS) on REF_IN			250	MHz
Duty Cycle Single	Duty cycle of REF_IN at $V_{CC}/2$	40%		60%	
Duty Cycle Diff	Duty cycle of REF_IN at $V_{CC}/2$	40%		60%	
AUXILARY_IN REQUIREMENTS					
$f_{REF-Single}$	For Single ended Inputs (LVCMOS) on AUX_IN	2		75	MHz
$f_{REF-Crystal}$	For Single ended Inputs (AT-Cut Crystal Input)	2		42	MHz
PD REQUIREMENTS					
t_r / t_f	Rise and fall time of the \overline{PD} signal from 20% to 80% of V_{CC}			4	ns

PHASE NOISE ANALYSIS

Table 2. Phase Noise for 30.72MHz External Reference

Phase Noise Specifications under following configuration: VCO = 1966.08 MHz, REF_IN = 30.72MHz, PFD Frequency = 30.72MHz, Charge Pump Current = 1.5mA Loop BW = 400kHz at 3.3V and 25°C.								
PHASE NOISE AT	Reference 30.72MHz	LVPECL-HP 491.52MHz	LVPECL 491.52MHz	LVDS-HP 491.52MHz	LVDS 491.52MHz	LVC MOS-HP 122.88MHz	LVC MOS 122.88MHz	UNIT
10Hz	-108	-84	-84	-85	-85	-97	-97	dBc/Hz
100Hz	-130	-98	-98	-98	-97	-110	-111	dBc/Hz
1kHz	-134	-106	-106	-106	-106	-118	-118	dBc/Hz
10kHz	-152	-118	-118	-118	-118	-130	-130	dBc/Hz
100kHz	-156	-121	-121	-121	-121	-133	-133	dBc/Hz
1MHz	-157	-131	-131	-130	-130	-143	-142	dBc/Hz
10MHz	—	-146	-146	-146	-145	-152	-151	dBc/Hz
20MHz	—	-146	-146	-146	-145	-152	-151	dBc/Hz
Jitter(RMS) 10k~20MHz	195 (10k~20MHz)	319	316	332.4	332.2	366.5	372.1	fs

Table 3. Phase Noise for 25MHz Crystal Reference

Phase Noise Specifications under following configuration: VCO = 2000.00 MHz, AUX_IN -REF = 25.00MHz, PFD Frequency = 25.00MHz, Charge Pump Current = 1.5mA Loop BW = 400kHz 3.3V and 25°C.					
Phase Noise at	Reference 25.00MHz	LVPECL-HP 500.00MHz	LVDS-HP 250.00MHz	LVC MOS-HP 125.00MHz	UNIT
10Hz	—	-72	-72	-79	dBc/Hz
100Hz	—	-97	-97	-103	dBc/Hz
1kHz	—	-111	-111	-118	dBc/Hz
10kHz	—	-120	-120	-126	dBc/Hz
100kHz	—	-124	-124	-130	dBc/Hz
1MHz	—	-136	-136	-142	dBc/Hz
10MHz	—	-147	-147	-151	dBc/Hz
20MHz	—	-148	-148	-151	dBc/Hz
Jitter(RMS) 10k~20MHz	—	426	426	443	fs

OUTPUT TO OUTPUT ISOLATION

Measurement Method

1. Connect output 1 to the phase noise and Spectrum analyzer.
2. Measure spurious on Outputs 1.
3. Enable aggressor channel 0
4. Measure spurious on Output 1
5. The difference between the spurious levels of Outputs 1 before and after enabling the aggressor channel determine the output-to-output isolation performance recorded.

Table 4. Output to Output Isolation

			WORST CASE SPUR	UNIT
The Output to Output Isolation was tested at 3.3V supply and 25°C ambient temperature (Default Configuration):				
Output 1	Measured Channel	In LVDS Signaling at 125MHz	-70	dB
<i>Output 0</i>	<i>Aggressor Channel</i>	<i>LVPECL 156.25MHz</i>		

SPI CONTROL INTERFACE TIMING

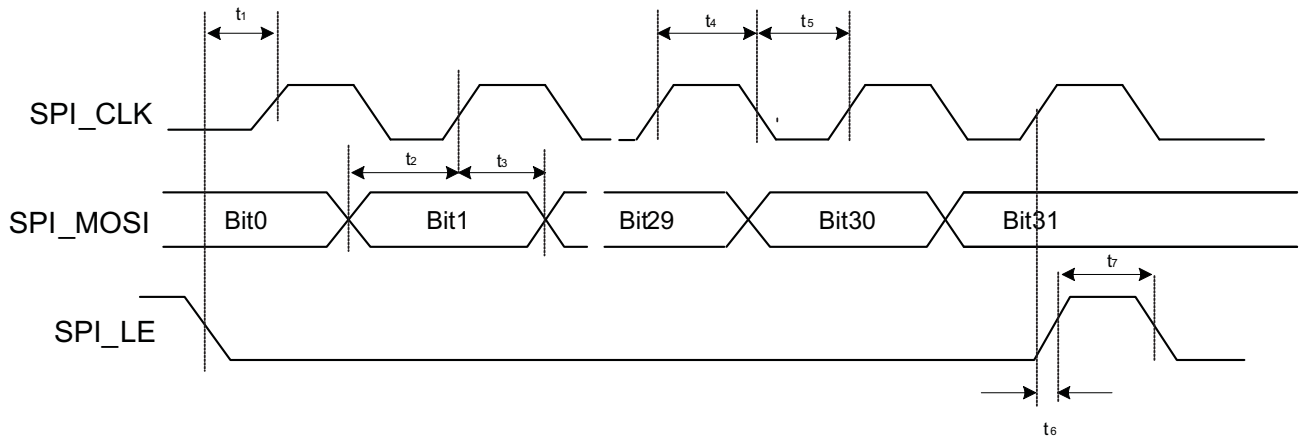

Figure 12. Timing Diagram for SPI Write Command

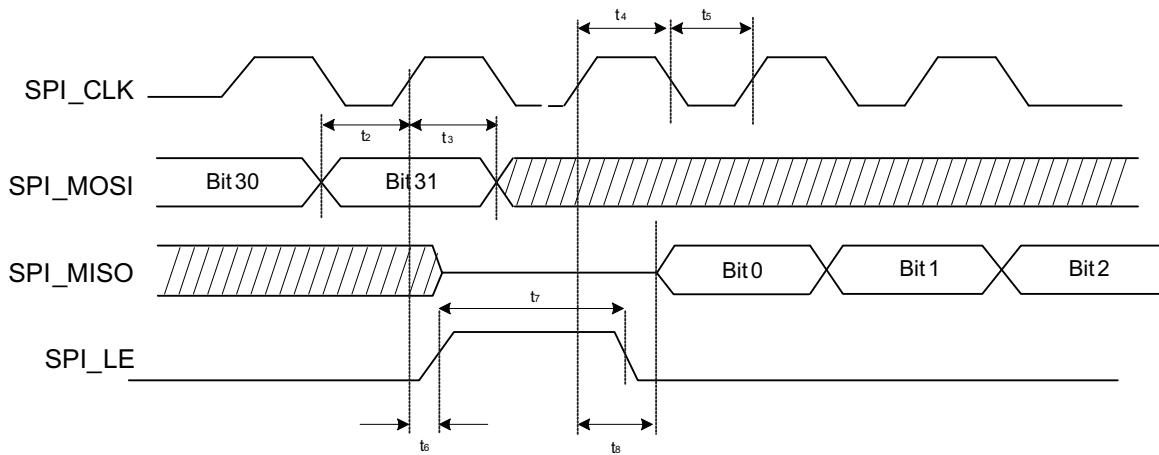

Figure 13. Timing Diagram for SPI Read Command

Table 5. SPI Bus Timing Characteristics

SPI BUS TIMINGS					
PARAMETER		MIN	TYP	MAX	UNIT
f_{Clock}	Clock Frequency for the SPI_CLK			20	MHz
t_1	SPI_LE to SPI_CLK setup time	10			ns
t_2	SPI_MOSI to SPI_CLK setup time	10			ns
t_3	SPI_MOSI to SPI_CLK hold time	10			ns
t_4	SPI_CLK high duration	25			ns
t_5	SPI_CLK low duration	25			ns
t_6	SPI_CLK to SPI_LE Setup time	10			ns
t_7	SPI_LE Pulse Width	20			ns
t_8	SPI_MISO to SPI_CLK Data Valid (First Valid Bit after LE)	10			ns

DEVICE CONFIGURATION

The Functional Description Section described four different functional blocks contained within the CDCE62002. Figure 14 depicts these blocks along with a high-level functional block diagram of the circuit elements comprising each block. The balance of this section focuses on a detailed discussion of each functional block from the perspective of how to configure them.

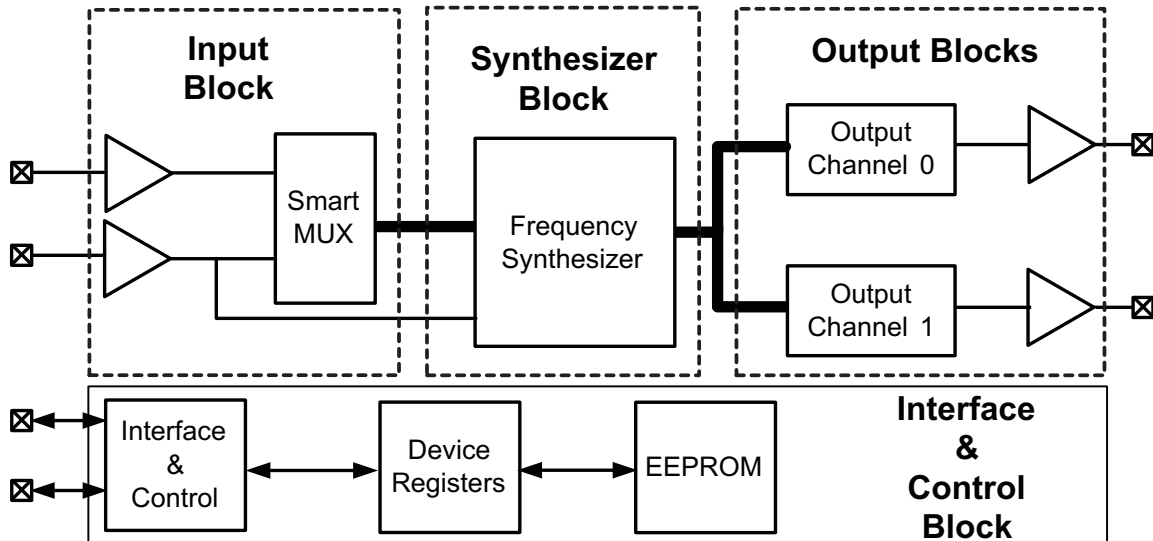

Figure 14. CDCE62002 Circuit Blocks

INTERFACE and CONTROL BLOCK

The Interface and Control Block includes a SPI interface, four control pins, a non-volatile memory array in which the device stores default configuration data, and an array of device registers implemented in Static RAM. This RAM, also called the device registers, configures all hardware within the CDCE62002.

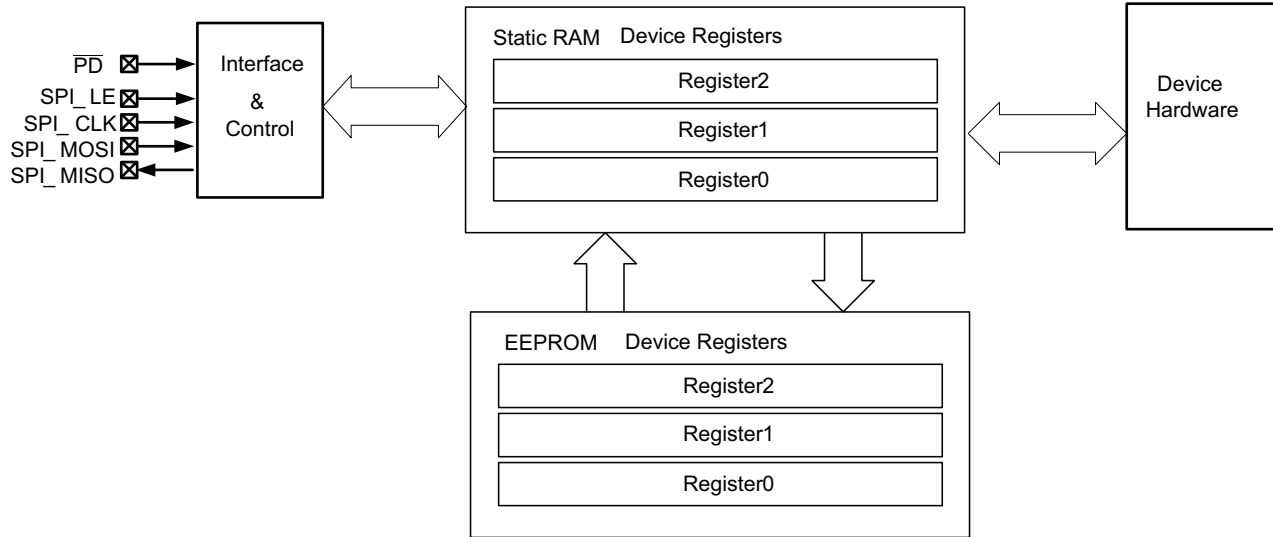

Figure 15. CDCE62002 Interface and Control Block

SPI (Serial Peripheral Interface)

The serial interface of CDCE62002 is a simple bidirectional SPI interface for writing and reading to and from the device registers. It implements a low speed serial communications link in a master/slave topology in which the CDCE62002 is a slave. The SPI consists of four signals:

- **SPI_CLK:** Serial Clock (Output from Master) – the CDCE62002 clocks data in and out on the rising edge of SPI_CLK. Data transitions therefore occur on the falling edge of the clock.
- **SPI_MOSI:** Master Output Slave Input (Output from Master).
- **SPI_MISO:** Master Input Slave Output (Output from Slave)
- **SPI_LE:** Latch Enable (Output from Master). The falling edge of SPI_LE initiates a transfer. If SPI_LE is high, no data transfer can take place.

The CDCE62002 implements data fields that are 28-bits wide. In addition, it contains 3 registers, each comprising a 28 bit data field. Therefore, accessing the CDCE62002 requires that the host program append a 4-bit address field to the front of the data field as follows:

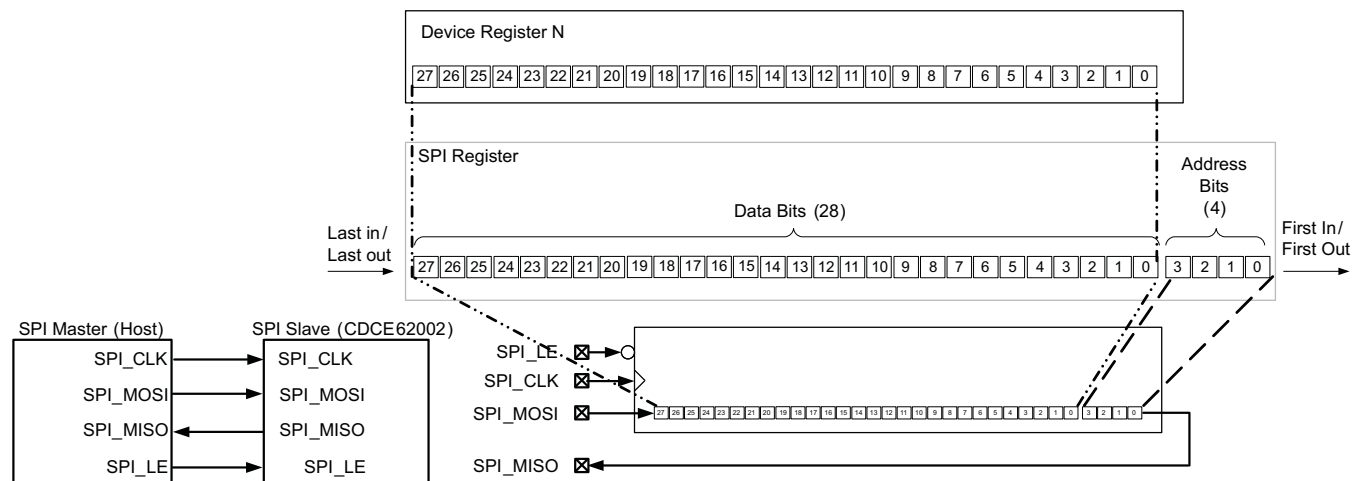

Figure 16. CDCE62002 SPI Communications Format

CDCE62002 SPI Command Structure

The CDCE62002 supports four commands issued by the Master via the SPI:

- Write to RAM
- Read Command
- Copy RAM to EEPROM – unlock
- Copy RAM to EEPROM – lock

Table 6 provides a summary of the CDCE62002 SPI command structure. The host (master) constructs a Write to RAM command by specifying the appropriate register address in the address field and appends this value to the beginning of the data field. Therefore, a valid command stream must include 32 bits, transmitted LSB first. The host must issue a Read Command to initiate a data transfer from the CDCE62002 back to the host. This command specifies the address of the register of interest in the data field.

Table 6. CDCE62002 SPI Command Structure

Register	Operation	NVM	Data Field (28 Bits)																												Addr Field (4 Bits)								
			27	26	25	24	23	22	21	20	19	18	17	16	15	14	13	12	11	10	9	8	7	6	5	4	3	2	1	0	3	2	1	0					
0	Write to RAM	Yes	X	X	X	X	X	X	X	X	X	X	X	X	X	X	X	X	X	X	X	X	X	X	X	X	X	X	X	X	X	X	X	X	0	0	0	0	
1	Write to RAM	Yes	X	X	X	X	X	X	X	X	X	X	X	X	X	X	X	X	X	X	X	X	X	X	X	X	X	X	X	X	X	X	X	X	X	0	0	0	1
2	Status/Control	No	X	X	X	X	X	X	X	X	X	X	X	X	X	X	X	X	X	X	X	X	X	X	X	X	X	X	X	X	X	X	X	X	X	0	0	1	0
Instruction	Read Command	No	0	0	0	0	0	0	0	0	0	0	0	0	0	0	0	0	0	0	0	0	0	0	0	0	0	0	0	A	A	A	A	1	1	1	0		
Instruction	RAM EEPROM	Unlock	0	0	0	0	0	0	0	0	0	0	0	0	0	0	0	0	0	0	0	0	0	0	0	0	0	0	0	0	0	0	0	0	0	1	1	1	1
Instruction	RAM EEPROM	Lock ⁽¹⁾	0	0	0	0	0	0	0	0	0	0	0	0	0	0	0	0	0	0	0	0	0	0	0	0	0	0	0	0	0	0	0	0	1	1	1	1	

(1) **CAUTION:** After execution of this command, the EEPROM is **permanently** locked. After locking the EEPROM, device configuration can only be changed via Write to RAM after power-up; however, the EEPROM can no longer be changed.

Writing to the CDCE62002

Figure 17 illustrates a Write to RAM operation. Notice that the latching of the first data bit in the data stream (Bit 0) occurs on the first rising edge of SPI_CLK after SPI_LE transitions from a high to a low. For the CDCE62002, data transitions occur on the falling edge of SPI_CLK. A rising edge on SPI_LE signals to the CDCE62002 that the transmission of the last bit in the stream (Bit 31) has occurred.

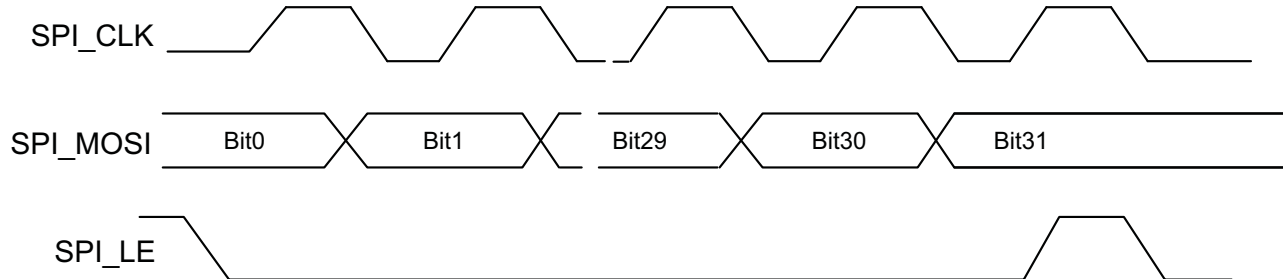

Figure 17. CDCE62002 SPI Write Operation

Reading from the CDCE62002

Figure 18 shows how the CDCE62002 executes a Read Command. The SPI master first issues a Read Command to initiate a data transfer from the CDCE62002 back to the host (see Table 6). This command specifies the address of the register of interest. By transitioning SPI_LE from a low to a high, the CDCE62002 resolves the address specified in the appropriate bits of the data field. The host drives SPI_LE low and the CDCE62002 presents the data present in the register specified in the Read Command on SPI_MISO.

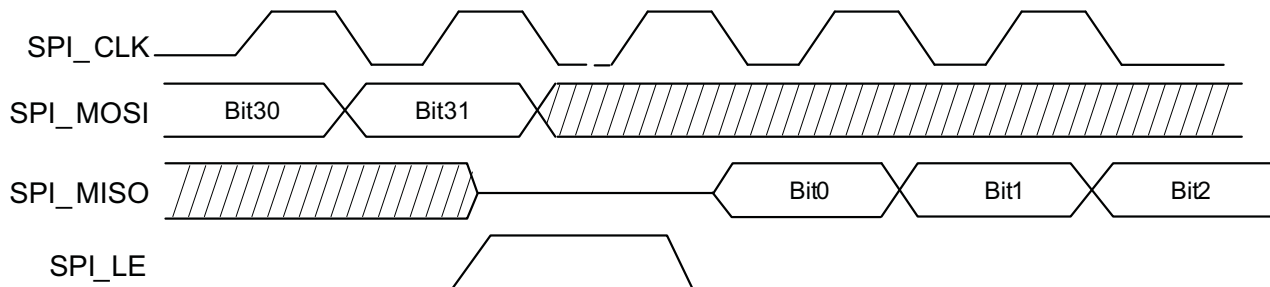

Figure 18. CDCE62002 Read Operation

Writing to EEPROM

After the CDCE62002 detects a power-up and completes a reset cycle, it copies the contents of the on-board EEPROM into the Device Registers. Therefore, the CDCE62002 initializes into a known state predefined by the user. The host issues one of two special commands shown in Table 6 to copy the contents of Device Registers 0 through 1 into EEPROM. They include:

- Copy RAM to EEPROM – Unlock, Execution of this command can happen many times.
- Copy RAM to EEPROM – Lock: Execution of this command can happen only once; after which the EEPROM is **permanently locked**.

After either command is initiated, power must remain stable and the host must not access the CDCE62002 for at least 50 ms to allow the EEPROM to complete the write cycle and to avoid the possibility of EEPROM corruption.

Device Registers: Register 0

Table 7. CDCE62002 Register 0 Bit Definitions

SPI BIT	RAM BIT	BIT NAME	RELATED BLOCK	DESCRIPTION / FUNCTION	
0		A0		Address 0	0
1		A1		Address 1	0
2		A2		Address 2	0
3		A3		Address 3	0
4	0	INBUFSELX	INBUFSELX	Input Buffer Select (LVPECL, LVDS or LVCMOS) XY(00) Disabled, (01) LVPECL, (10) LVDS, (11) LVCMOS The VBB internal Biasing will be determined from this setting	EEPROM
5	1	INBUFSLEY	INBUFSLEY		EEPROM
6	2	REFSEL	Smart MUX Bits(2,3)	<i>See specific section for more detailed description and configuration setup.</i> 00 – RESERVED 10 – REF_IN Select 01 – AUX_IN Select 11 – Auto Select (Reference then AUX)	EEPROM
7	3	AUXSEL			EEPROM
8	4	ACDCSEL	Input Buffers	If Set to "1" DC Termination, If set to "0" AC Termination	EEPROM
9	5	TERMSEL	Input Buffers	If Set to "0" Input Buffer Internal Termination Enabled	EEPROM
10	6	REFDIVIDE 0		Reference Divider Settings. <i>See specific section for more detailed description and configuration setup.</i>	EEPROM
11	7	REFDIVIDE 1			EEPROM
12	8	REFDIVIDE 2			EEPROM
13	9	REFDIVIDE 3			EEPROM
14	10	EXTFEEDBACK		External Feedback to PFD from AUX Input enabled when set to "1"	EEPROM
15	11	<i>I70TEST</i>	<i>TEST</i>	<i>Set to "0" for Normal Operation.</i>	EEPROM
16	12	<i>ATETEST</i>	<i>TEST</i>	<i>Set to "0" for Normal Operation.</i>	EEPROM
17	13	LOCKW(0)	PLL Lock	Lock-detect window Bit 0	EEPROM
18	14	LOCKW(1)	PLL Lock	Lock-detect window Bit 1	EEPROM
19	15	OUT0DIVRSEL0	Output 0	Output 0 Divider Settings. <i>See specific section for more detailed description and configuration setup.</i>	EEPROM
20	16	OUT0DIVRSEL1	Output 0		EEPROM
21	17	OUT0DIVRSEL2	Output 0		EEPROM
22	18	OUT0DIVRSEL3	Output 0		EEPROM
23	19	OUT1DIVRSEL0	Output 1	Output 1 Divider Settings. <i>See specific section for more detailed description and configuration setup.</i>	EEPROM
24	20	OUT1DIVRSEL1	Output 1		EEPROM
25	21	OUT1DIVRSEL2	Output 1		EEPROM
26	22	OUT1DIVRSEL3	Output 1		EEPROM
27	23	HIPERORMANCE	Output 0 & 1	High Performance, If this Bit is set to "1": – Increase the Bias in the device to achieve Best Phase Noise on the Output Divider – It changes the LVPECL Buffer to Hi Swing in LVPECL. – It increases the current consumption by 20mA (Typical)	EEPROM
28	24	OUTBUFSEL0X	Output 0	Output Buffer mode select for OUTPUT "0". (X,Y)=00:Disabled, 01:LVCMOS, 10:LVDS, 11:LVPECL	EEPROM
29	25	OUTBUFSEL0Y	Output 0		EEPROM
30	26	OUTBUFSEL1X	Output 1	Output Buffer mode select for OUTPUT "1". (X,Y)=00:Disabled, 01:LVCMOS, 10:LVDS, 11:LVPECL	EEPROM
31	27	OUTBUFSEL1Y	Output 1		EEPROM

Table 8. Reference Input AC/DC Input Termination Table

REFERENCE INPUT	RAM BITS				VBB VOLTAGE	REF+ TERMINATION	REF– TERMINATION
INTERNAL TERMINATION	0	1	4	5	GENERATOR	5kΩ to VBB	5kΩ to VBB
External Termination	X	X	X	1	OFF	OPEN	OPEN
Disabled	0	0	X	X	OFF	OPEN	OPEN
LVC MOS	1	1	X	0	OFF	OPEN	OPEN
LVPECL-AC	0	1	0	0	1.9V	CLOSED	CLOSED
LVPECL-DC	0	1	1	0	1.0V	CLOSED	CLOSED
LVDS-AC	1	0	0	0	1.2V	CLOSED	CLOSED
LVDS-DC	1	0	1	0	1.2V	CLOSED	CLOSED

Device Registers: Register 1

Table 9. CDCE62002 Register 1 Bit Definitions

SPI BIT	RAM BIT	BIT NAME	RELATED BLOCK	DESCRIPTION / FUNCTION	
0		A0		Address 0	1
1		A1		Address 1	0
2		A2		Address 2	0
3		A3		Address 3	0
4	0	SELVCO	VCO Core	VCO Select	EEPROM
5	1	SELINDIV0	VCO Core	Input Divider Settings.	EEPROM
6	2	SELINDIV1	VCO Core	<i>See specific section for more detailed description and configuration setup.</i>	EEPROM
7	3	SELINDIV2	VCO Core		EEPROM
8	4	SELINDIV3	VCO Core		EEPROM
9	5	SELINDIV4	VCO Core		EEPROM
10	6	SELINDIV5	VCO Core		EEPROM
11	7	SELINDIV6	VCO Core		EEPROM
12	8	SELINDIV7	VCO Core		EEPROM
13	9	SELPRESCA	VCO Core	PRESCALER Setting.	EEPROM
14	10	SELPRESCB	VCO Core	<i>See specific section for more detailed description and configuration setup.</i>	EEPROM
15	11	SELFBDIV0	VCO Core	FEEDBACK DIVIDER Setting	EEPROM
16	12	SELFBDIV1	VCO Core	<i>See specific section for more detailed description and configuration setup.</i>	EEPROM
17	13	SELFBDIV2	VCO Core		EEPROM
18	14	SELFBDIV3	VCO Core		EEPROM
19	15	SELFBDIV4	VCO Core		EEPROM
20	16	SELFBDIV5	VCO Core		EEPROM
21	17	SELFBDIV6	VCO Core		EEPROM
22	18	SELFBDIV7	VCO Core		EEPROM
23	19	SELBPDIV0	VCO Core	BYPASS DIVIDER Setting (6 settings + Disable + Enable)	EEPROM
24	20	SELBPDIV1	VCO Core	<i>See specific section for more detailed description and configuration setup.</i>	EEPROM
25	21	SELBPDIV2	VCO Core		EEPROM
26	22	LFRCSEL0	VCO Core	Loop Filter & Charge Pump Control Setting	EEPROM
27	23	LFRCSEL1	VCO Core	<i>See specific section for more detailed description and configuration setup.</i>	EEPROM
28	24	LFRCSEL2	VCO Core		EEPROM
29	25	LFRCSEL3	VCO Core		EEPROM
30	26	EELOCK	Status	If EELOCK reads "0" EEPROM is unlocked. If EELOCK reads "1," then EEPROM is locked.	EEPROM
31	27	RESERVED	Status	Read Only always reads "1"	EEPROM

Device Registers: Register 2
Table 10. CDCE62002 Register 2 Bit Definitions

SPI BIT	RAM BIT	BIT NAME	RELATED BLOCK	DESCRIPTION / FUNCTION	
0		A0		Address 0	0
1		A1		Address 1	1
2		A2		Address 2	0
3		A3		Address 3	0
4	0	RESERVED	Diagnostics	<i>TI Test Registers. For TI Use Only</i>	RAM
5	1	RESERVED	Diagnostics	<i>TI Test Registers. For TI Use Only</i>	RAM
6	2	RESERVED	Diagnostics	<i>TI Test Registers. For TI Use Only</i>	RAM
7	3	RESERVED	Diagnostics	<i>TI Test Registers. For TI Use Only</i>	RAM
8	4	RESERVED	Diagnostics	<i>TI Test Registers. For TI Use Only</i>	RAM
9	5	RESERVED	Diagnostics	<i>TI Test Registers. For TI Use Only</i>	RAM
10	6	PLLLOCKPIN	Status	Read Only: Status of the PLL Lock Pin Driven by the device. PLL Lock = 1	RAM
11	7	\overline{PD}	Control	Power Down mode "On" when set to "0", Off when set to "1" is normal operation (PD bit does not load the EEPROM into RAM when set to "1").	RAM
12	8	\overline{SYNC}	Control	If toggled "1-0-1" this bit forces " \overline{SYNC} " resynchronize the Output Dividers.	RAM
13	9	RESERVED	Diagnostics	<i>TI Test Registers. For TI Use Only</i>	RAM
14	10	VERSION0	Read Only		RAM
15	11	VERSION1	Read Only		RAM
16	12	VERSION2	Read Only		RAM
17	13	PLLRESET	VCO Core	If toggled "0-1-0" it Resets PLL to start calibration. "0" is normal operation.	RAM
18	14	RESERVED	Diagnostics	<i>TI Test Registers. For TI Use Only</i>	RAM
19	15	RESERVED	Diagnostics	<i>TI Test Registers. For TI Use Only</i>	RAM
20	16	RESERVED	Diagnostics	<i>TI Test Registers. For TI Use Only</i>	RAM
21	17	RESERVED	Diagnostics	<i>TI Test Registers. For TI Use Only</i>	RAM
22	18	RESERVED	Diagnostics	<i>TI Test Registers. For TI Use Only</i>	RAM
23	19	RESERVED	Diagnostics	<i>TI Test Registers. For TI Use Only</i>	RAM
24	20	RESERVED	Diagnostics	<i>TI Test Registers. For TI Use Only</i>	RAM
25	21	TITSTCFG0	Diagnostics	<i>TI Test Registers. For TI Use Only</i>	RAM
26	22	TITSTCFG1	Diagnostics	<i>TI Test Registers. For TI Use Only</i>	RAM
27	23	TITSTCFG2	Diagnostics	<i>TI Test Registers. For TI Use Only</i>	RAM
28	24	TITSTCFG3	Diagnostics	<i>TI Test Registers. For TI Use Only</i>	RAM
29	25	RESERVED	Diagnostics	<i>TI Test Registers. For TI Use Only</i>	RAM
30	26	RESERVED	Diagnostics	<i>TI Test Registers. For TI Use Only</i>	RAM
31	27	RESERVED	Diagnostics	<i>TI Test Registers. For TI Use Only</i>	RAM

Device Control

Figure 19 provides a conceptual explanation of the CDCE62002 Device operation. Table 11 defines how the device behaves in each of the operational states.

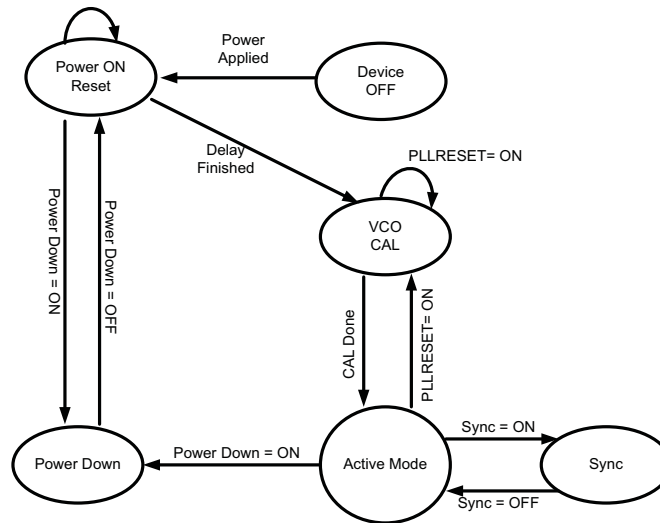

Figure 19. CDCE62002 Device State Control Diagram

Table 11. CDCE62002 Device State Definitions

State	Device Behavior	Entered Via	Exited Via	SPI Port Status	PLL Status	Output Divider Status	Output Buffer Status
Power-On Reset	After device power supply reaches approximately 2.35V, the contents of EEPROM are copied into the Device Registers, thereby initializing the device hardware .	Power applied to the device or upon exit from Power Down State via the \overline{PD} pin set HIGH.	Power On Reset and EEPROM loading delays are finished OR the \overline{PD} pin is set LOW.	OFF	Disabled	Disabled	OFF
VCO CAL	The voltage controlled oscillator is calibrated based on the PLL settings and the incoming reference clock. After the VCO has been calibrated, the device enters Active Mode automatically.	Delay process in the Power-On Reset State is finished or PLLRESET=ON	Calibration Process in completed	ON	Enabled	Disabled	OFF
Active Mode	Normal Operation	CAL Done (VCO calibration process finished) or Sync = OFF (from Sync State).	Power Down or PLLRESET=ON	ON	Enabled	Disabled or Enabled	Disabled or Enabled
Power Down	Used to shut down all hardware and Resets the device after exiting the Power Down State. Therefore, the EEPROM contents will eventually be copied into RAM after the Power Down State is exited.	\overline{PD} pin is pulled LOW.	\overline{PD} pin is pulled HIGH.	ON	Disabled	Disabled	Disabled
Sync	Sync synchronizes both outputs dividers so that they begin counting at the same time	\overline{Sync} Bit in device register 2 bit 8 is set LOW	\overline{Sync} bit in device register 2 bit 8 is set HIGH	ON	Enabled	Disabled	Disabled

External Control Pins

Power Down (\overline{PD})

When pulled LOW, \overline{PD} activates the Power Down state which shuts down all hardware and resets the device. Restoring \overline{PD} high will cause the CDCE62002 to exit the Power Down State. This causes the device to behave as if it has been powered up including copying the EEPROM contents into RAM. \overline{PD} pin also has a shadowed \overline{PD} bit residing in Register 2 Bit 7. When asserted Low it puts the device in Power Down Mode, but it does not load the EEPROM when the bits is disasserted.

NOTE:

The SPI_LE signal has to be high in order for the EEPROM to load correctly into RAM on the Rising edge of $\overline{\text{PD}}$ Pin.

FACTORY DEFAULT PROGRAMMING

The CDCE62002 is factory pre-programmed to work with 25 MHz input from the reference input or from the auxiliary input with auto switching enabled. An internal PFD of 6.25 MHz and about 400 KHz loop bandwidth. Output 0 is pre-programmed as an LCPECL driver to output 156.25 MHz and output 1 is pre-programmed as LVDS driver to output 125 MHz.

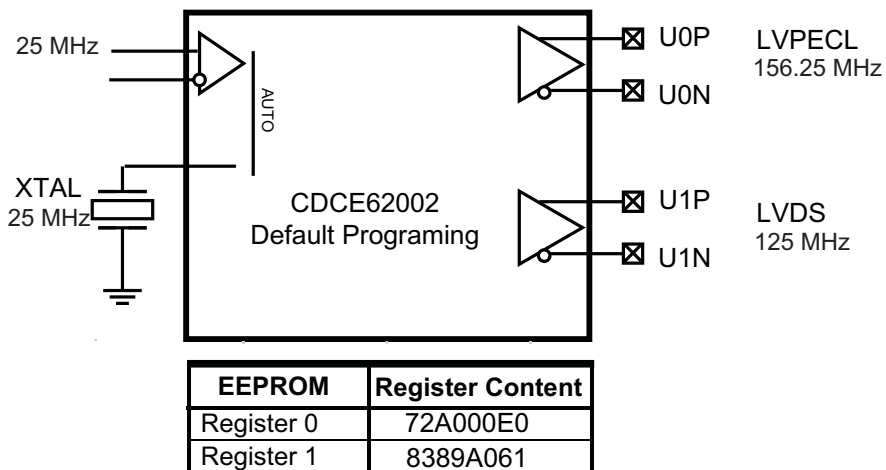

Figure 20. CDCE62002 Default Factory Programming

INPUT BLOCK

The Input Block includes one Universal Input Buffers, an Auxiliary Input, and a Smart Multiplexer.

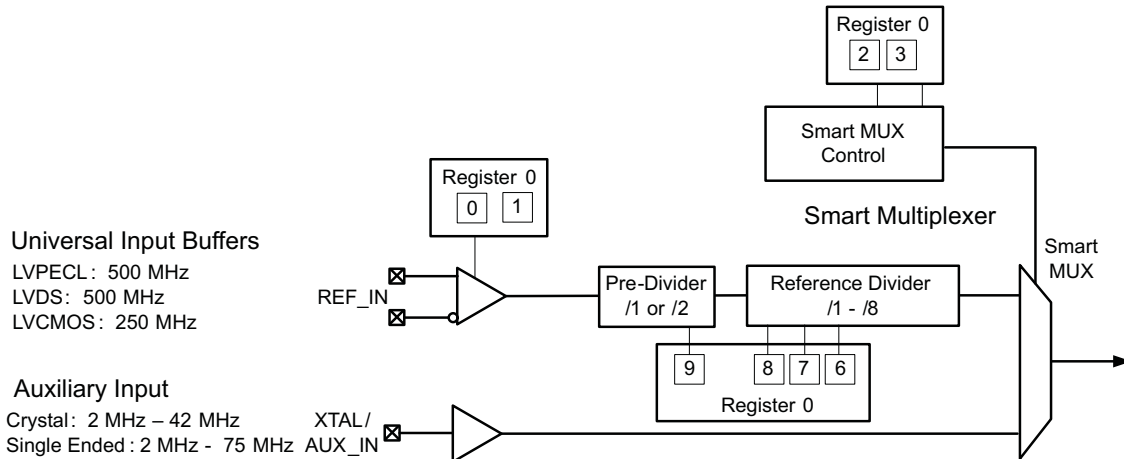

Figure 21. CDCE62002 Input Block With References to Registers

The CDCE62002 provides a Reference Divider that divides the clock exiting Reference (REF_IN) input buffer.

Table 12. CDCE62002 Reference Divider Settings

BIT NAME → REGISTER BIT →	REFERENCE DIVIDER				TOTAL DIVIDE RATIO
	REFDIVIDE3	REFDIVIDE2	REFDIVIDE1	REFDIVIDE0	
	0.9	0.8	0.7	0.6	
	0	0	0	0	/1
	0	0	0	1	/2
	0	0	1	0	/3
	0	0	1	1	/4
	0	1	0	0	/5
	0	1	0	1	/6
	0	1	1	0	/7
	0	1	1	1	/8
	1	0	0	0	/2
	1	0	0	1	/4
	1	0	1	0	/6
	1	0	1	1	/8
	1	1	0	0	/10
	1	1	0	1	/12
	1	1	1	0	/14
	1	1	1	1	/16

Reference Input Buffer

Figure 22 shows the key elements of a Universal Input Buffer (UIB). A UIB supports multiple formats along with different termination and coupling schemes. The CDCE62002 implements the UIB by including on board switched termination, a programmable bias voltage generator, and a multiplexer. The CDCE62002 provides a high degree of configurability on the UIB to facilitate most existing clock input formats.

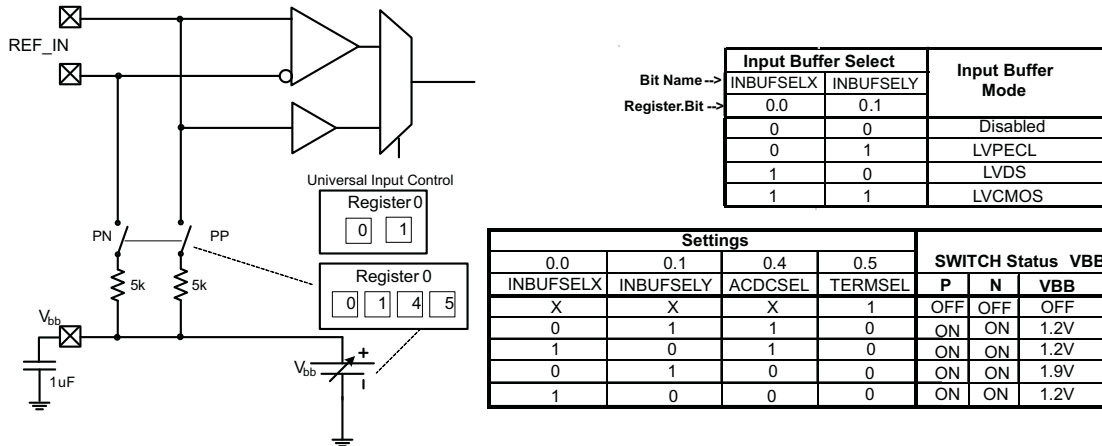

Figure 22. CDCE62002 Universal Input Buffer

Smart Multiplexer Dividers

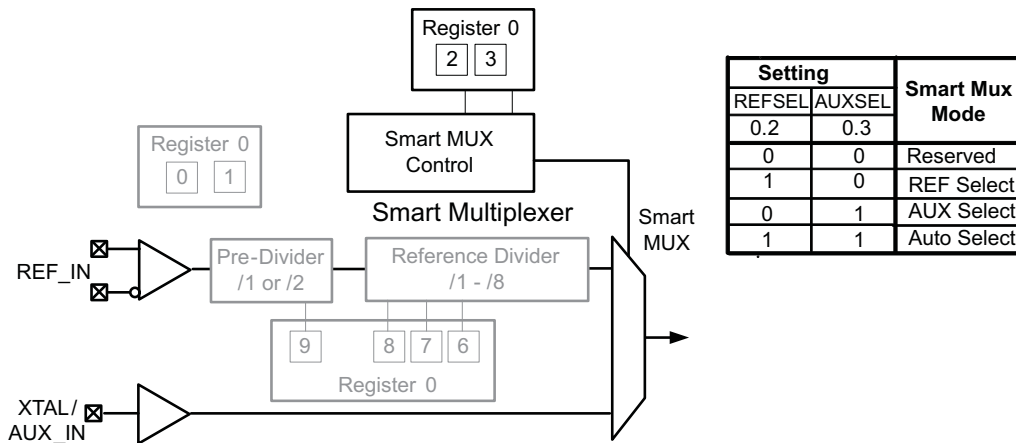

Figure 23. CDCE62002 Smart Multiplexer

In Auto Select Mode the Smart Mux switches automatically between Reference input and Auxiliary input with a preference to the Reference input. In order for the Smart Mux to function correctly the frequency after the reference divider and the Auxiliary Input signal frequency should be within 20% of each other or one of them should be zero or ground. In This mode a valid frequency needs to be present on AUX_IN before the /PD is deasserted or power is applied.

Auxiliary Input Port

The auxiliary input on the CDCE62002 is designed to connect to an AT-Cut Crystal with a total load capacitance of 8 pF to 18pF. One side of the crystal connects to Ground while the other side connects to the Auxiliary input of the device. The circuit accepts crystals from 2 to 42 MHz.

Since the Auxiliary input operates between 0 and 2 Volts with a crystal, it can accept single-ended signals (e.g., LVCMOS). Electrically, it is equivalent to an LVCMOS input buffer with 8 pF of input capacitance.

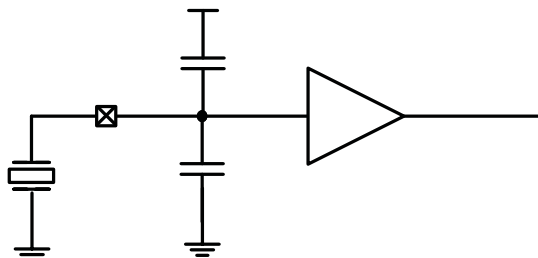

Figure 24. CDCE62002 Auxiliary Input Port

External Feedback Mode

The auxiliary input on the CDCE62002 is to serve as an external feedback port if Bit (10) in Register 0 is set to "1" and input smart Mux setting is set to Reference input. In addition, The Reference Divider and the input divider have to be set to divide by 1. This feature is implemented to allow direct access to the PFD of the PLL. The delay from Reference input to PFD and from Auxiliary Reference to PFD is not matched. However, in close loop system where the device output is fed to close the loop the delay difference between the Reference and External feedback path will cancel out.

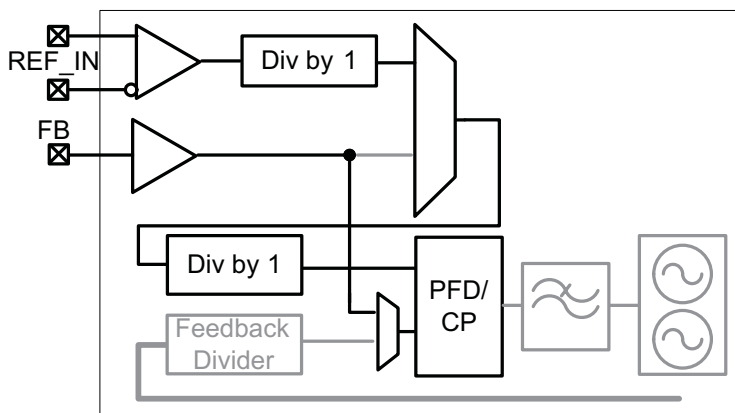

Figure 25. CDCE62002 in External Feedback Mode

OUTPUT BLOCK

The output block includes two identical output channels. Each output channel comprises of a clock divider module, and a universal output buffer as shown in Figure 26.

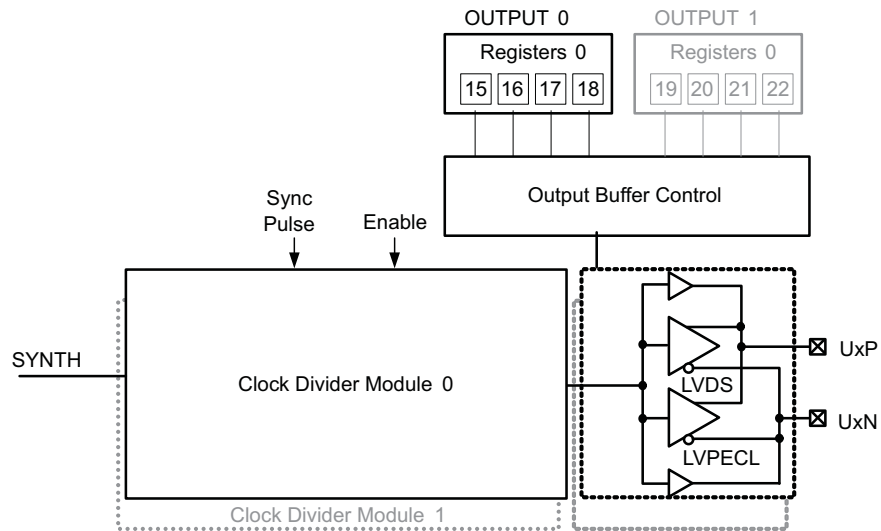

Figure 26. CDCE62002 Output Channel

Table 13. CDCE62002 Output Divider Settings

DIVER 0 → DIVER 1 →	OUTPUT DIVIDERS SETTING				DIVIDE RATIO
	0.18	0.17	0.16	0.15	
	0.22	0.21	0.20	0.19	
	0	0	0	0	Disabled
	0	0	0	1	/1
	0	0	1	0	/2
	0	0	1	1	/3
	0	1	0	0	/4
	0	1	0	1	/5
	0	1	1	0	/6
	0	1	1	1	Disabled
	1	0	0	0	/8
	1	0	0	1	Disabled
	1	0	1	0	/10
	1	0	1	1	/20
	1	1	0	0	/12
	1	1	0	1	/24
	1	1	1	0	/16
	1	1	1	1	/32

SYNTHESIZER BLOCK

Figure 27 provides an overview of the CDCE62002 synthesizer block. The Synthesizer Block provides a Phase Locked Loop, a partially integrated programmable loop filter, and two Voltage Controlled Oscillators (VCO). The synthesizer block generates an output clock called “SYNTH” and drives it onto the Internal Clock Distribution Bus.

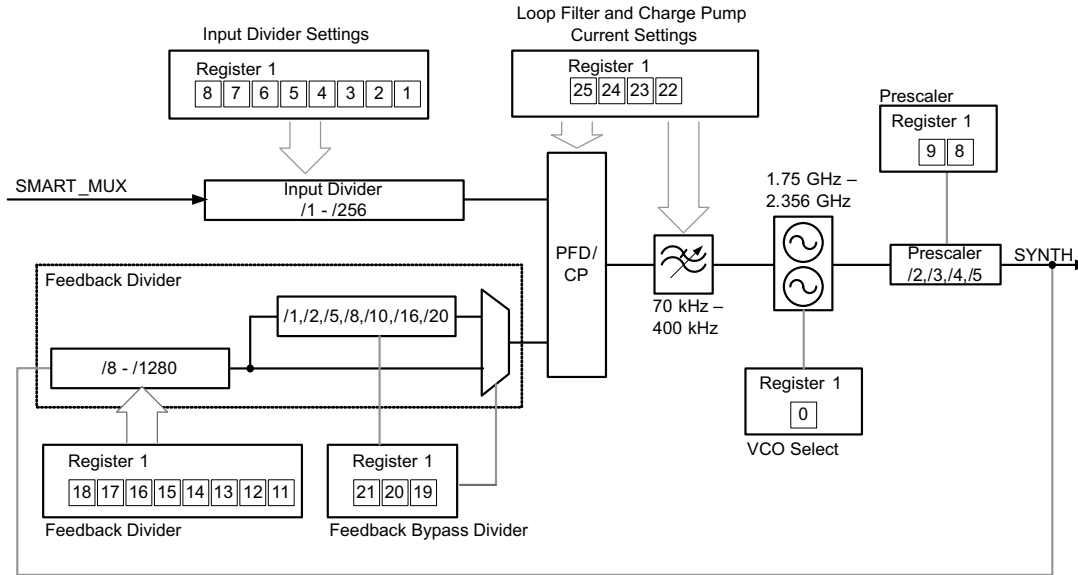

Figure 27. CDCE62002 Synthesizer Block

Input Divider

The Input Divider divides the clock signal selected by the Smart Multiplexer and presents the divided signal to the Phase Frequency Detector / Charge Pump of the frequency synthesizer.

Table 14. CDCE62002 Input Divider Settings

INPUT DIVIDER SETTINGS								DIVIDE RATIO
SELINDIV7	SELINDIV6	SELINDIV5	SELINDIV4	SELINDIV3	SELINDIV2	SELINDIV1	SELINDIV0	
1.8	1.7	1.6	1.5	1.4	1.3	1.2	1.1	
0	0	0	0	0	0	0	0	1
0	0	0	0	0	0	0	1	2
0	0	0	0	0	0	1	0	3
0	0	0	0	0	0	1	1	4
0	1	0	0	0	1	0	0	5
0	1	0	0	0	1	0	1	6
–	–	–	–	–	–	–	–	–
–	–	–	–	–	–	–	–	–
1	1	1	1	1	1	1	1	256

Feedback and Feedback Bypass Divider

Table 15 shows how to configure the Feedback divider for various divide values:

Table 15. CDCE62002 Feedback Divider Settings

FEEDBACK DIVIDER								DIVIDE RATIO
SELFBDIV7	SELFBDIV6	SELFBDIV5	SELFBDIV4	SELFBDIV3	SELFBDIV2	SELFBDIV1	SELFBDIV0	
1.18	1.17	1.16	1.15	1.14	1.13	1.12	1.11	8
0	0	0	0	0	0	0	0	12
0	0	0	0	0	0	1	1	16
0	0	0	0	0	0	1	1	20
0	0	0	0	0	1	0	1	24
0	0	0	0	0	1	1	0	32
0	0	0	0	1	0	0	1	36
0	0	0	0	0	1	1	1	40
0	0	0	0	1	0	1	0	48
0	0	0	1	1	0	0	0	56
0	0	0	0	1	0	1	1	60
0	0	0	0	1	1	1	0	64
0	0	0	1	0	1	0	1	72
0	0	0	0	1	1	1	1	80
0	0	0	1	1	0	0	1	84
0	0	0	1	0	1	1	0	96
0	0	0	1	0	0	1	1	100
0	1	1	0	1	0	0	1	108
0	0	0	1	1	0	1	0	112
0	0	0	1	0	1	1	1	120
0	0	0	1	1	1	1	0	128
0	0	0	1	1	0	1	1	140
0	0	0	1	0	1	0	1	144
0	0	0	1	1	1	1	1	160
0	0	1	1	1	1	1	1	168
0	1	0	0	1	0	1	1	180
0	0	1	1	0	1	1	0	192
0	0	1	1	0	0	1	1	200
0	1	0	1	0	1	0	1	216
0	0	1	1	1	0	1	0	224
0	0	1	1	0	1	1	1	240
0	1	0	1	1	0	0	1	252
0	0	1	1	1	1	1	0	256
0	0	1	1	1	0	1	1	280
0	1	0	1	0	1	1	0	288
0	1	0	1	0	0	1	1	300
0	0	1	1	1	1	1	1	320
0	1	0	1	1	0	1	0	336
0	1	0	1	0	1	1	1	360
0	1	0	1	1	1	1	0	384
1	1	0	1	1	0	0	0	392
0	1	1	1	0	0	1	1	400

Table 15. CDCE62002 Feedback Divider Settings (continued)

FEEDBACK DIVIDER								DIVIDE RATIO
SELFBDIV7	SELFBDIV6	SELFBDIV5	SELFBDIV4	SELFBDIV3	SELFBDIV2	SELFBDIV1	SELFBDIV0	
1.18	1.17	1.16	1.15	1.14	1.13	1.12	1.11	
0	1	0	1	1	0	1	1	420
1	0	1	1	0	1	0	1	432
0	1	1	1	1	0	1	0	448
0	1	0	1	1	1	1	1	480
1	0	0	1	0	0	1	1	500
1	0	1	1	1	0	0	1	504
0	1	1	1	1	1	1	0	512
0	1	1	1	1	0	1	1	560
1	0	1	1	0	1	1	0	576
1	1	0	1	1	0	0	1	588
1	0	0	1	0	1	1	1	600
0	1	1	1	1	1	1	1	640
1	0	1	1	1	0	1	0	672
1	0	0	1	1	0	1	1	700
1	0	1	1	0	1	1	1	720
1	0	1	1	1	1	1	0	768
1	1	0	1	1	0	1	0	784
1	0	0	1	1	1	1	1	800
1	0	1	1	1	0	1	1	840
1	1	0	1	1	1	1	0	896
1	0	1	1	1	1	1	1	960
1	1	0	1	1	0	1	1	980
1	1	1	1	1	1	1	0	1024
1	1	0	1	1	1	1	1	1120
1	1	1	1	1	1	1	1	1280

Table 16 shows how to configure the Feedback Bypass Divider.

Table 16. CDCE62002 Feedback Bypass Divider Settings

FEEDBACK BYPASS DIVIDER			DIVIDE RATIO
SELBPDIV2	SELBPDIV1	SELBPDIV0	
1.21	1.20	1.19	
0	0	0	2
0	0	1	5
0	1	0	8
0	1	1	10
1	0	0	16
1	0	1	20
1	1	0	RESERVED
1	1	1	1(bypass)

VCO Select

Table 17 illustrates how to control the dual voltage controlled oscillators.

Table 17. CDCE62002 VCO Select

BIT NAME →	VCO SELECT SELVCO	VCO CHARACTERISTICS		
REGISTER NAME →	1.0	VCO RANGE	Fmin (MHz)	Fmax (MHz)
	0	Low	1750	2046
	1	High	2040	2356

Prescaler

Table 18 shows how to configure the prescaler.

Table 18. CDCE62002 Prescaler Settings

SETTINGS		DIVIDE RATIO
SELPRESCB	SELPRESCA	
1.10	1.9	
0	0	5
1	0	4
0	1	3
1	1	2

Loop Filter

Figure 28 depicts the loop filter topology of the CDCE62002. It facilitates both internal and external implementations providing optimal flexibility.

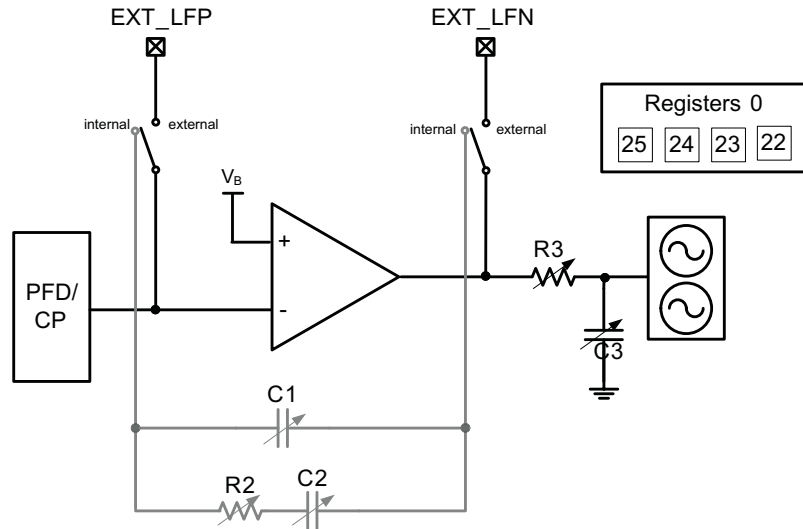

Figure 28. CDCE62002 Loop Filter Topology

Internal Loop Filter Component Configuration

Figure 28 illustrates the switching between four fixed internal loop filter settings and the external loop filter setting. Table 19 shows that the CDCE62002 has 16 settings different settings for the loop filter. Four of the settings are internal and twelve are external.

Table 19. CDCE62002 Loop Filter Settings

LFRCSSEL				Loop Filter	C1	C2	R2	R3	C3	3 db Corner C3R3	Charge Pump Current
3	2	1	0								
0	0	0	0	Internal	1.5 pF	473.5 pF	4.0k	5k	2.5 pF	12 MHz	1.5 mA
0	0	0	1	Internal	1.5 pF	473.5 pF	4.0k	5k	2.5 pF	12 MHz	400 μA
0	0	1	0	Internal	1.5 pF	473.5 pF	2.7k	5k	2.5 pF	12 MHz	250 μA
0	0	1	1	Internal	1.5 pF	473.5 pF	2.7k	5k	2.5 pF	12 MHz	150 μA
0	1	0	0	External	X	X	X	20k	112 pF	70 kHz	1.0 mA
0	1	0	1	External	X	X	X	20k	112 pF	70 kHz	2.0 mA
0	1	1	0	External	X	X	X	20k	112 pF	70 kHz	3.0 mA
0	1	1	1	External	X	X	X	20k	112 pF	70 kHz	3.75 mA
1	0	0	0	External	X	X	X	10k	100 pF	150 kHz	1.0 mA
1	0	0	1	External	X	X	X	10k	100 pF	150 kHz	2.0 mA
1	0	1	0	External	X	X	X	10k	100 pF	150 kHz	3.0 mA
1	0	1	1	External	X	X	X	10k	100 pF	150 kHz	3.75 mA
1	1	0	0	External	X	X	X	5k	100 pF	300 kHz	1.0 mA
1	1	0	1	External	X	X	X	5k	64 pF	500 kHz	2.0 mA
1	1	1	0	External	X	X	X	5k	48 pF	700 kHz	3.0 mA
1	1	1	1	External	X	X	X	5k	38 pF	800 kHz	3.75 mA

Lock Detect

The CDCE62002 provides a lock detect indicator circuit that can be detected on an external Pin PLL_LOCK (Pin 32) and internally by reading PLLLOCKPIN bit (6) in Register 2.

Two signals whose phase difference is less than a prescribed amount are 'locked' otherwise they are 'unlocked'. The phase frequency detector / charge pump compares the clock provided by the input divider and the feedback divider; using the input divider as the phase reference. The lock detect circuit implements a programmable lock detect window. Table 20 shows an overview of how to configure the lock detect feature. The PLL_LOCK pin will possibly jitter several times between lock and out of lock until the PLL achieves a stable lock. If desired, choosing a wide loop bandwidth and a high number of successive clock cycles virtually eliminates this characteristic. PLL_LOCK will return to out of lock, if just one cycle is outside the lock detect window or if a cycle slip occurs.

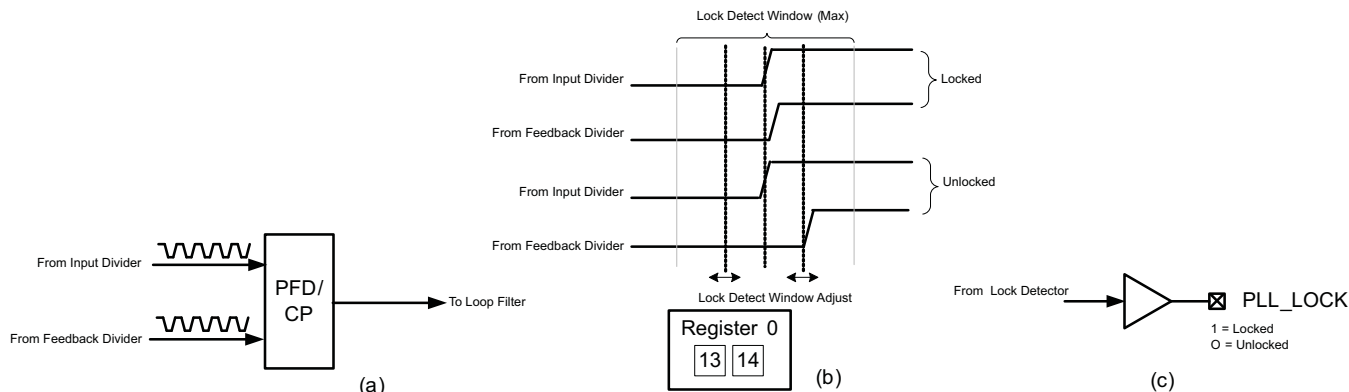

Figure 29. CDCE62002 Lock Detect

Table 20. CDCE62002 Lock Detect Control

BIT NAME →	LOCK DETECT		LOCK DETECT WINDOW
	LOCKW(1)	LOCKW(0)	
REGISTER NAME →	0.13	0.14	
	0	0	2.1 ns
	0	1	4.6 ns
	1	0	7.2 ns
	1	1	19.9 ns

Device Power Calculation and Thermal Management

The CDCE62002 is a high performance device; therefore careful attention must be paid to device configuration and printed circuit board layout with respect to power consumption. Table 21 provides the power consumption for the individual blocks within the CDCE62002. To estimate total power consumption, calculate the sum of the products of the number of blocks used and the power dissipated of each corresponding block.

Table 21. CDCE62002 Power Consumption

INTERNAL BLOCK (Power at 3.3V)	POWER DISSIPATED PER BLOCK	NUMBER OF BLOCKS PER DEVICE
Input Circuit	32	1
PLL and VCO Core	333	1
Output Divider	92	2
Output Buffer (LVPECL)	150	2
Output Buffer (LVDS)	95	2
Output Buffer (LVCMOS)	62	4

This power estimate determines the degree of thermal management required for a specific design. Observing good thermal layout practices enables the thermal pad on the backside of the QFN-32 package to provide a good thermal path between the die contained within the package and the ambient air. This thermal pad also serves as the ground connection the device; therefore, a low inductance connection to the ground plane is essential.

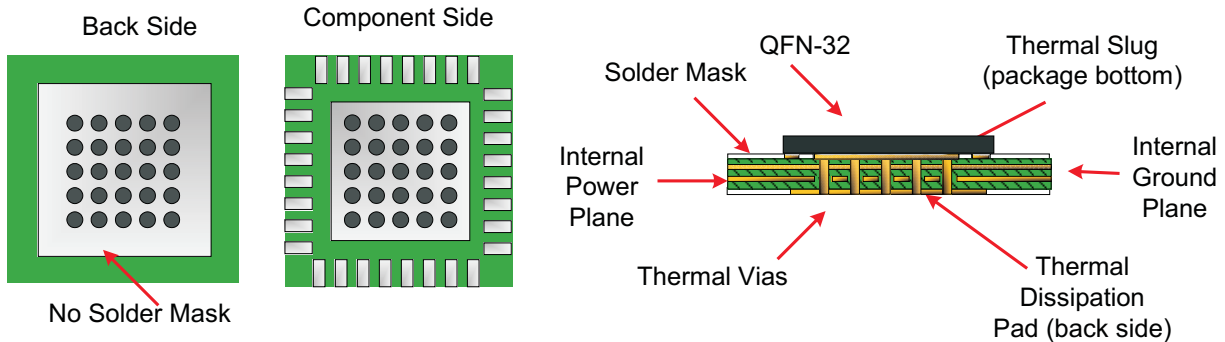

Figure 30. CDCE62002 Recommended PCB Layout

CDCE62002 Power Supply Bypassing – Recommended Layout

Figure 31 shows a conceptual layout focusing on power supply bypass capacitor placement. If the capacitors are mounted on the back side, 0402 components can be employed; however, soldering to the Thermal Dissipation Pad can be difficult. If the capacitors are mounted on the component side, 0201 components must be used to facilitate signal routing. In either case, the connections between the capacitor and the power supply terminal on the device must be kept as short as possible.

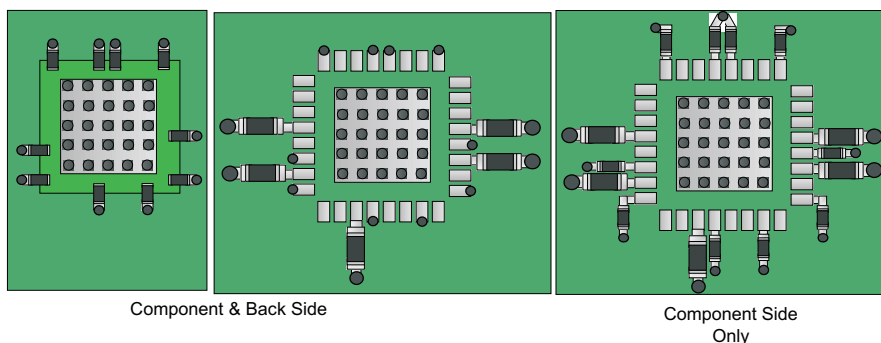

Figure 31. CDCE62002 Power Supply Bypassing

APPLICATION INFORMATION AND GENERAL USAGE HINTS

Clock Generator

The CDCE62002 can generate 1 to 4 low noise clocks from a single crystal or crystal oscillator as follows:

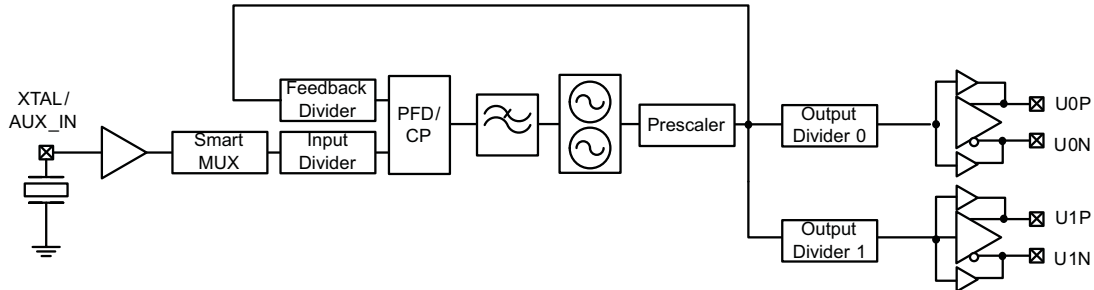

Figure 32. CDCE62002 as a Clock Generator

External Feedback Option

The CDCE62002 has a limited optional external feedback path that give access to the PFD inside the device. This option enables customers to implement complex or custom PLL designed to control the VCO inside the CDCE62002. In addition, the External feedback allows the device to operate in a deterministic delay mode where the reference to output delay is fixed but dependable on the routing path length from the outputs to the auxiliary input pin. Figure 33 illustrates how the output is loopback to the Auxiliary Input in bypass mode to put the device in fixed delay mode.

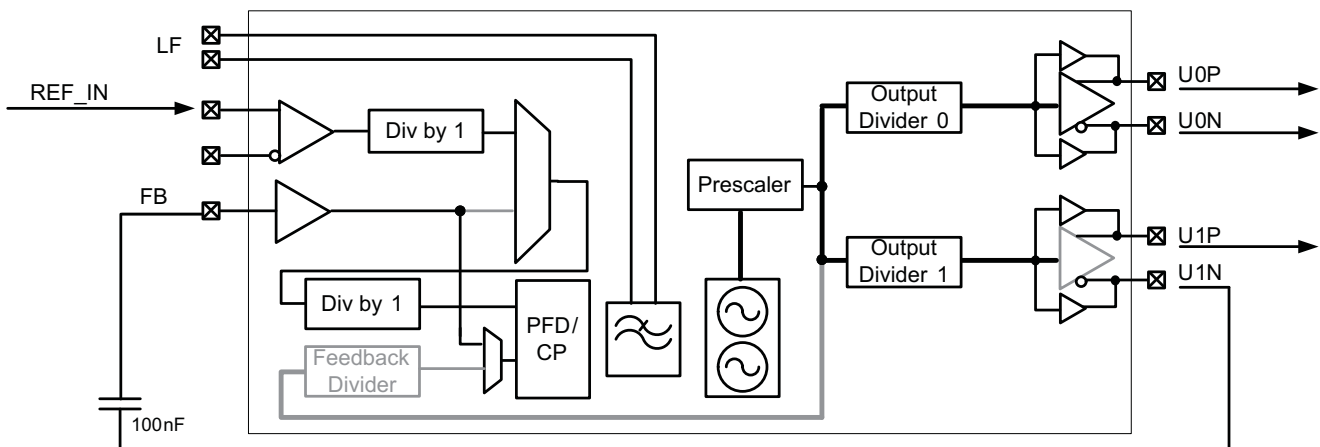

Figure 33. CDCE62002 External Feedback Example

This function is limited by the output divider divide ratio and can be implemented when one of the outputs is set from 10.94 MHz to 40.00MHz.

SERDES Startup and Clock Cleaner

The CDCE62002 can serve as a SERDES device companion by providing a crystal based reference for the SERDES device to lock to receive data stream and when the SERDES locks to the data and outputs the recovered clock the CDCE62002 can switch and use the recovered clock and serve as a jitter cleaner.

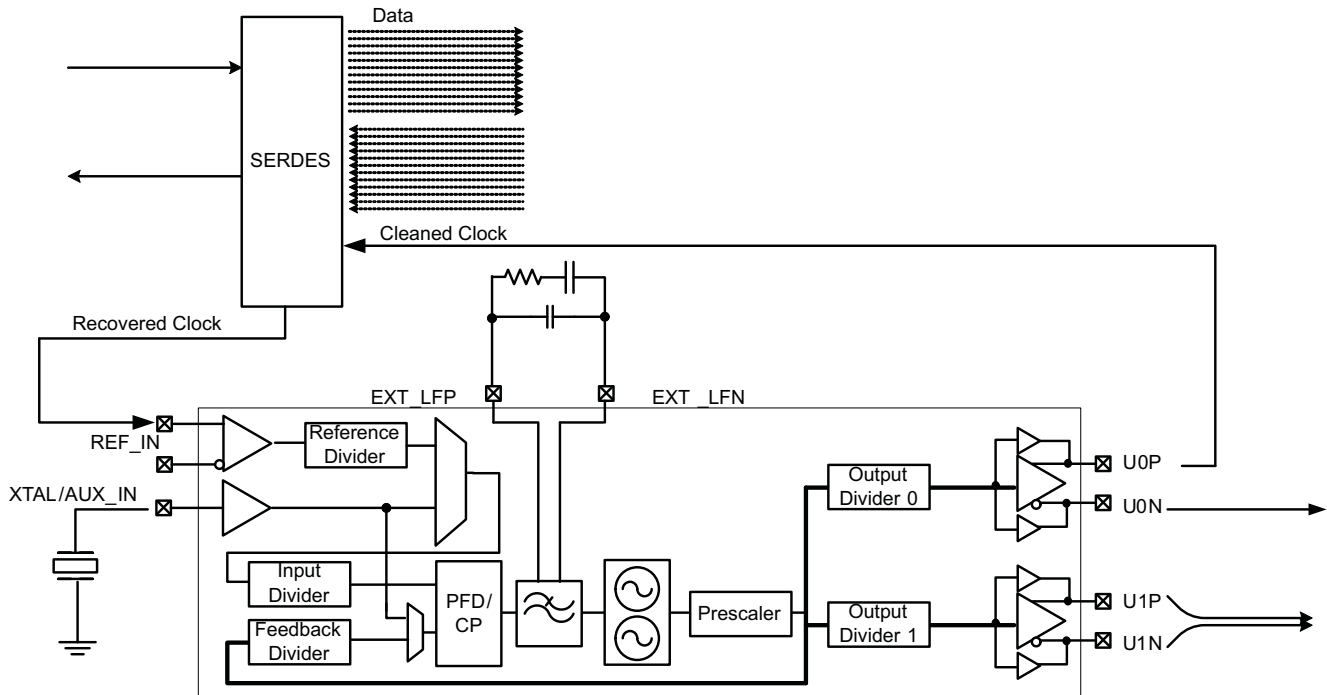

Figure 34. CDCE62002 Clocking SERDES

Since the jitter of the recovered clock can be above 100 ps (RMS) the output jitter from CDCE62002 can be as low and 6 ps (RMS) depending on the external loop filter configuration.

CLOCKING ADCS WITH THE CDCE62002

High-speed analog to digital converters incorporate high input bandwidth on both the analog port and the sample clock port. Often the input bandwidth far exceeds the sample rate of the converter. Engineers regularly implement receiver chains that take advantage of the characteristics of bandpass sampling. This implementation trend often causes engineers working in communications system design to encounter the term “clock limited performance”. Therefore, it is important to understand the impact of clock jitter on ADC performance. The following equation shows the relationship of data converter signal to noise ratio (SNR) to total jitter:

$$\text{SNR}_{\text{jitter}} = 20\log_{10} \left[\frac{1}{2\pi f_{\text{in}} \text{jitter}_{\text{total}}} \right] \quad (4)$$

Total jitter comprises two components: the intrinsic aperture jitter of the converter and the jitter of the sample clock:

$$\text{jitter}_{\text{total}} = \sqrt{(\text{jitter}_{\text{ADC}})^2 + (\text{jitter}_{\text{CLK}})^2} \quad (5)$$

With respect to an ADC with N-bits of resolution, ignoring total jitter, ADC quantization error, and input noise, the following equation shows the relationship between resolution and SNR:

$$\text{SNR}_{\text{ADC}} = 6.02N + 1.76 \quad (6)$$

Figure 35 plots Equation 4 and Equation 6 for constant values of total jitter. When used in conjunction with most ADCs, the CDCE62002 supports a total jitter performance value of <1ps.

Data Converter Jitter Requirements

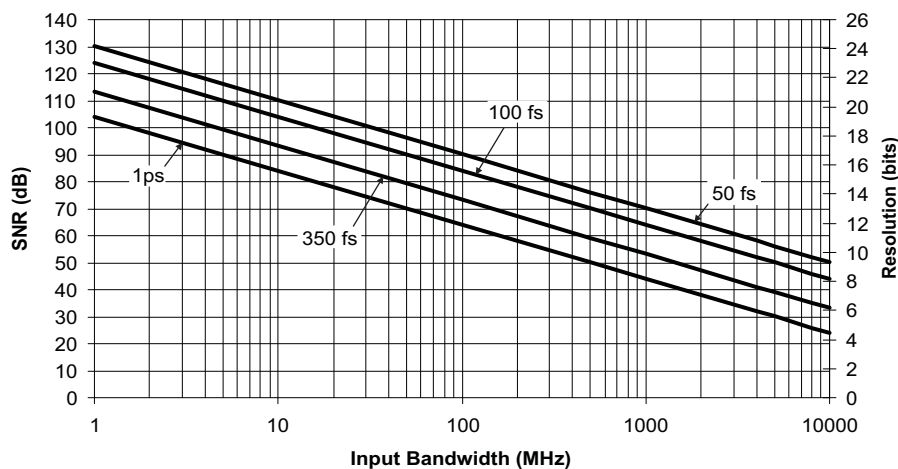

Figure 35. Data Converter Jitter Requirements

REVISION HISTORY

Changes from Original (June 2009) to Revision A	Page
• Added information - The input has an internal 150-kΩ pull-up resist	3
• Deleted (as described in later future revisions of this document).....	3
• Added NOTE: All VCC pins need to be connected for the device to operate properly.	3
• Changed graphic input naming	4
• Changed graphic input naming	5
• Changed W to mW	8
• Changed W to mW	8
• Changed W to mW	8
• Changed W to mW	8
• Deleted underscore before IN+.....	8
• Deleted 6 from 8006	11
• Changed Y4 to Y1	12
• Added MIN, TYP, and MAX values.....	12
• Added (Reg 0 RAM bit 9 = 1)	14
• Added (Reg 0 RAM bit 9 = 0)	14
• Changed REF into REF_IN	14
• Changed AUX into AUX_IN	14
• Deleted t9 from timing.....	16
• Changed input naming.....	18
• Changed part number error	19
• Changed REFERENCE to REF_IN and AUXILARY to AUX_IN	22
• Changed power to current	22
• Changed 0110 to 1000	24
• Changed 0001 to 0100	25
• Changed description for RAM BIT to - TI Test Registers. For TI Use Only	25
• Changed graphic.....	26
• Changed table information.....	26
• Changed PDDRESET to PLLRESET	26
• Changed Power_Down to PD	26
• Changed PRI_IN to REF_IN.....	28
• Changed PRI_IN to REF_IN.....	29
• Added sentence - In This mode a valid frequency needs to be present on AUX_IN before the /PD is deasserted or power is applied.....	29
• Changed PRI_IN to REF_IN.....	40

PACKAGING INFORMATION

Orderable Device	Status ⁽¹⁾	Package Type	Package Drawing	Pins	Package Qty	Eco Plan ⁽²⁾	Lead/Ball Finish	MSL Peak Temp ⁽³⁾
CDCE62002RHBR	ACTIVE	QFN	RHB	32	3000	Green (RoHS & no Sb/Br)	CU NIPDAU	Level-2-260C-1 YEAR
CDCE62002RHBT	ACTIVE	QFN	RHB	32	250	Green (RoHS & no Sb/Br)	CU NIPDAU	Level-2-260C-1 YEAR

⁽¹⁾ The marketing status values are defined as follows:

ACTIVE: Product device recommended for new designs.

LIFEBUY: TI has announced that the device will be discontinued, and a lifetime-buy period is in effect.

NRND: Not recommended for new designs. Device is in production to support existing customers, but TI does not recommend using this part in a new design.

PREVIEW: Device has been announced but is not in production. Samples may or may not be available.

OBsolete: TI has discontinued the production of the device.

⁽²⁾ Eco Plan - The planned eco-friendly classification: Pb-Free (RoHS), Pb-Free (RoHS Exempt), or Green (RoHS & no Sb/Br) - please check <http://www.ti.com/productcontent> for the latest availability information and additional product content details.

TBD: The Pb-Free/Green conversion plan has not been defined.

Pb-Free (RoHS): TI's terms "Lead-Free" or "Pb-Free" mean semiconductor products that are compatible with the current RoHS requirements for all 6 substances, including the requirement that lead not exceed 0.1% by weight in homogeneous materials. Where designed to be soldered at high temperatures, TI Pb-Free products are suitable for use in specified lead-free processes.

Pb-Free (RoHS Exempt): This component has a RoHS exemption for either 1) lead-based flip-chip solder bumps used between the die and package, or 2) lead-based die adhesive used between the die and leadframe. The component is otherwise considered Pb-Free (RoHS compatible) as defined above.

Green (RoHS & no Sb/Br): TI defines "Green" to mean Pb-Free (RoHS compatible), and free of Bromine (Br) and Antimony (Sb) based flame retardants (Br or Sb do not exceed 0.1% by weight in homogeneous material)

⁽³⁾ MSL, Peak Temp. -- The Moisture Sensitivity Level rating according to the JEDEC industry standard classifications, and peak solder temperature.

Important Information and Disclaimer:The information provided on this page represents TI's knowledge and belief as of the date that it is provided. TI bases its knowledge and belief on information provided by third parties, and makes no representation or warranty as to the accuracy of such information. Efforts are underway to better integrate information from third parties. TI has taken and continues to take reasonable steps to provide representative and accurate information but may not have conducted destructive testing or chemical analysis on incoming materials and chemicals. TI and TI suppliers consider certain information to be proprietary, and thus CAS numbers and other limited information may not be available for release.

In no event shall TI's liability arising out of such information exceed the total purchase price of the TI part(s) at issue in this document sold by TI to Customer on an annual basis.

TAPE AND REEL INFORMATION

QUADRANT ASSIGNMENTS FOR PIN 1 ORIENTATION IN TAPE

*All dimensions are nominal

Device	Package Type	Package Drawing	Pins	SPQ	Reel Diameter (mm)	Reel Width W1 (mm)	A0 (mm)	B0 (mm)	K0 (mm)	P1 (mm)	W (mm)	Pin1 Quadrant
CDCE62002RHBR	QFN	RHB	32	3000	330.0	12.4	5.3	5.3	1.5	8.0	12.0	Q2
CDCE62002RHBT	QFN	RHB	32	250	330.0	12.4	5.3	5.3	1.5	8.0	12.0	Q2

TAPE AND REEL BOX DIMENSIONS

*All dimensions are nominal

Device	Package Type	Package Drawing	Pins	SPQ	Length (mm)	Width (mm)	Height (mm)
CDCE62002RHBR	QFN	RHB	32	3000	340.5	333.0	20.6
CDCE62002RHBT	QFN	RHB	32	250	340.5	333.0	20.6

RHB (S-PQFP-N32)

PLASTIC QUAD FLATPACK

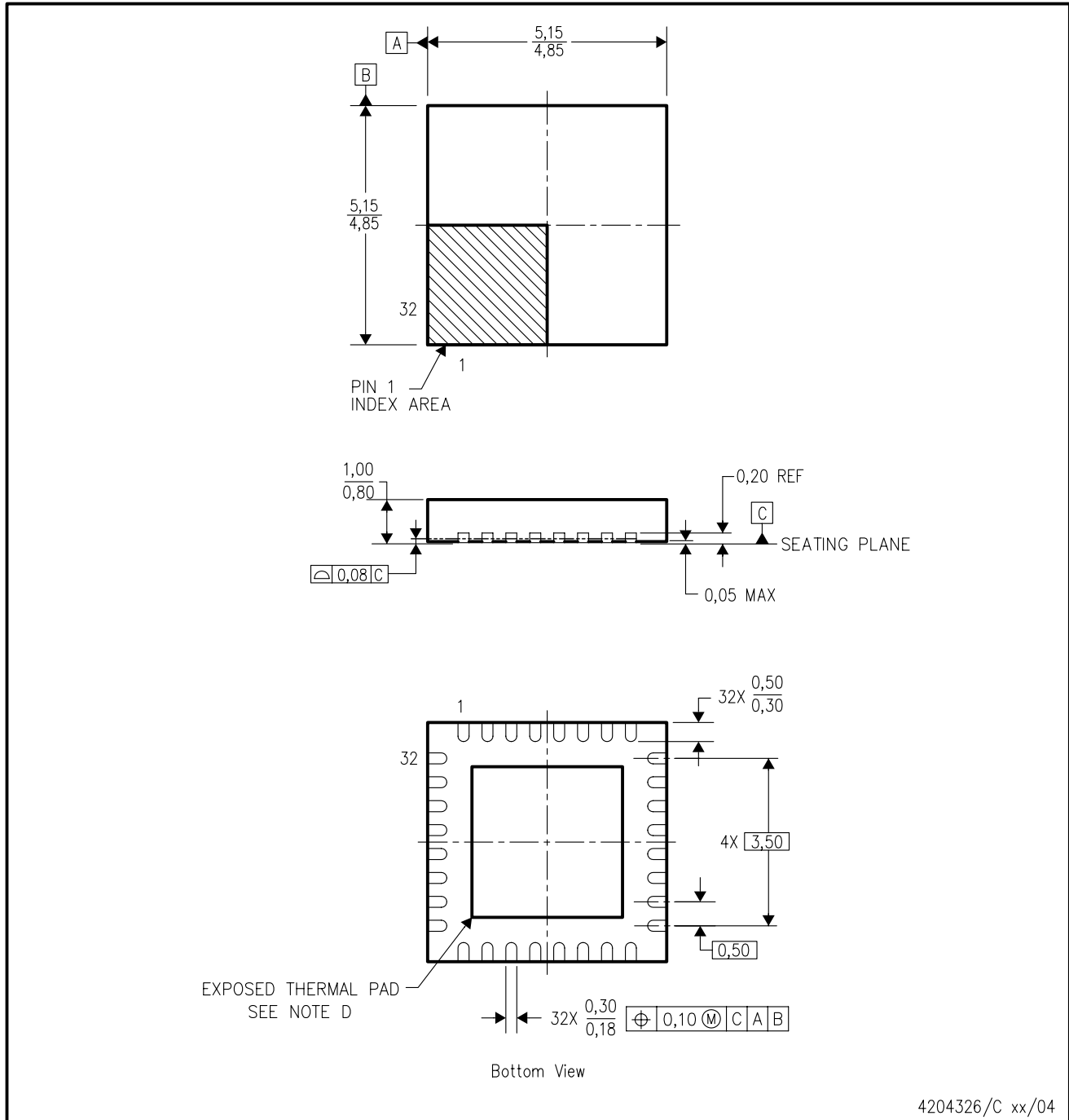

- NOTES:
- A. All linear dimensions are in millimeters.
 - B. This drawing is subject to change without notice.
 - C. QFN (Quad Flatpack No-Lead) Package configuration.
 - D. The Package thermal pad must be soldered to the board for thermal and mechanical performance. See product data sheet for details regarding the exposed thermal pad dimensions.
 - E. Falls within JEDEC MO-220.

THERMAL INFORMATION

This package incorporates an exposed thermal pad that is designed to be attached directly to an external heatsink. The thermal pad must be soldered directly to the printed circuit board (PCB). After soldering, the PCB can be used as a heatsink. In addition, through the use of thermal vias, the thermal pad can be attached directly to the appropriate copper plane shown in the electrical schematic for the device, or alternatively, can be attached to a special heatsink structure designed into the PCB. This design optimizes the heat transfer from the integrated circuit (IC).

For information on the Quad Flatpack No-Lead (QFN) package and its advantages, refer to Application Report, QFN/SON PCB Attachment, Texas Instruments Literature No. SLUA271. This document is available at www.ti.com.

The exposed thermal pad dimensions for this package are shown in the following illustration.

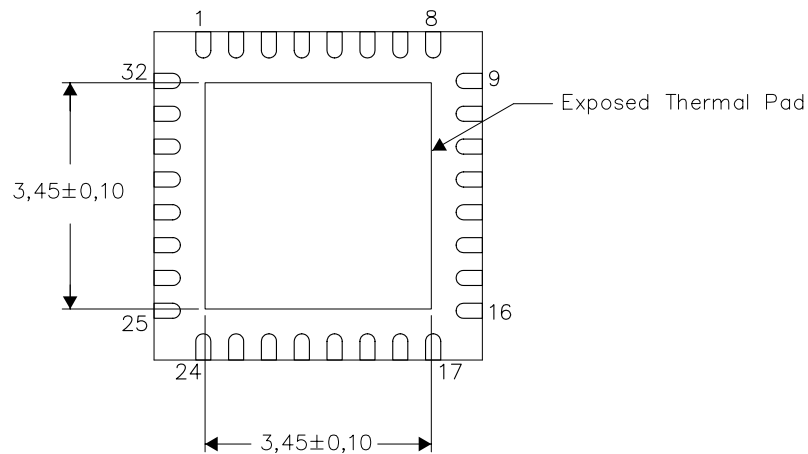

Bottom View

NOTE: All linear dimensions are in millimeters

Exposed Thermal Pad Dimensions

RHB (S-PQFP-N32)

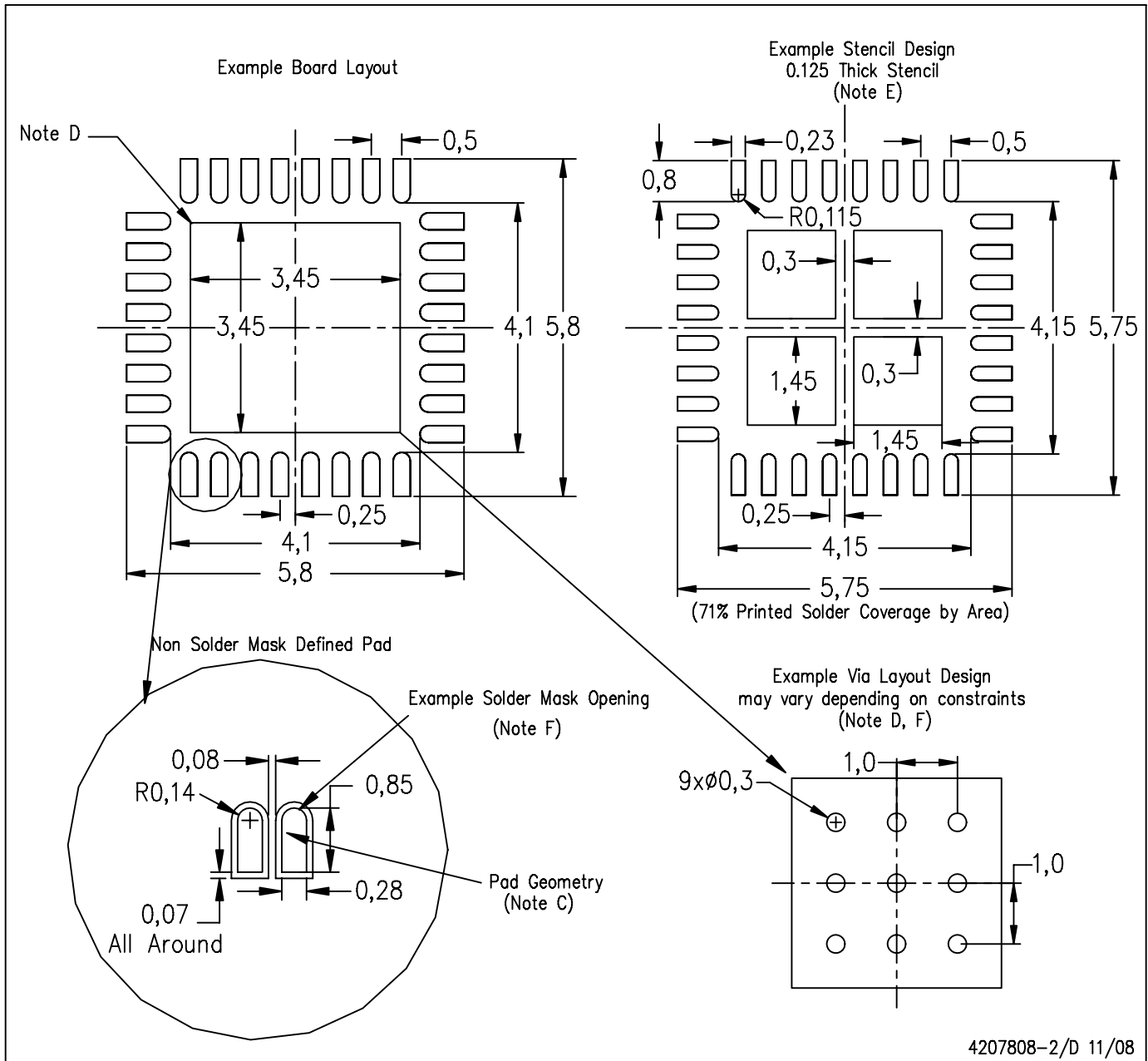

- NOTES:
- All linear dimensions are in millimeters.
 - This drawing is subject to change without notice.
 - Publication IPC-7351 is recommended for alternate designs.
 - This package is designed to be soldered to a thermal pad on the board. Refer to Application Note, Quad Flat-Pack Packages, Texas Instruments Literature No. SCBA017, SLUA271, and also the Product Data Sheets for specific thermal information, via requirements, and recommended board layout. These documents are available at www.ti.com <<http://www.ti.com>>.
 - Laser cutting apertures with trapezoidal walls and also rounding corners will offer better paste release. Customers should contact their board assembly site for stencil design recommendations. Refer to IPC 7525 for stencil design considerations.
 - Customers should contact their board fabrication site for recommended solder mask tolerances and via tenting recommendations for vias placed in the thermal pad.

IMPORTANT NOTICE

Texas Instruments Incorporated and its subsidiaries (TI) reserve the right to make corrections, modifications, enhancements, improvements, and other changes to its products and services at any time and to discontinue any product or service without notice. Customers should obtain the latest relevant information before placing orders and should verify that such information is current and complete. All products are sold subject to TI's terms and conditions of sale supplied at the time of order acknowledgment.

TI warrants performance of its hardware products to the specifications applicable at the time of sale in accordance with TI's standard warranty. Testing and other quality control techniques are used to the extent TI deems necessary to support this warranty. Except where mandated by government requirements, testing of all parameters of each product is not necessarily performed.

TI assumes no liability for applications assistance or customer product design. Customers are responsible for their products and applications using TI components. To minimize the risks associated with customer products and applications, customers should provide adequate design and operating safeguards.

TI does not warrant or represent that any license, either express or implied, is granted under any TI patent right, copyright, mask work right, or other TI intellectual property right relating to any combination, machine, or process in which TI products or services are used. Information published by TI regarding third-party products or services does not constitute a license from TI to use such products or services or a warranty or endorsement thereof. Use of such information may require a license from a third party under the patents or other intellectual property of the third party, or a license from TI under the patents or other intellectual property of TI.

Reproduction of TI information in TI data books or data sheets is permissible only if reproduction is without alteration and is accompanied by all associated warranties, conditions, limitations, and notices. Reproduction of this information with alteration is an unfair and deceptive business practice. TI is not responsible or liable for such altered documentation. Information of third parties may be subject to additional restrictions.

Resale of TI products or services with statements different from or beyond the parameters stated by TI for that product or service voids all express and any implied warranties for the associated TI product or service and is an unfair and deceptive business practice. TI is not responsible or liable for any such statements.

TI products are not authorized for use in safety-critical applications (such as life support) where a failure of the TI product would reasonably be expected to cause severe personal injury or death, unless officers of the parties have executed an agreement specifically governing such use. Buyers represent that they have all necessary expertise in the safety and regulatory ramifications of their applications, and acknowledge and agree that they are solely responsible for all legal, regulatory and safety-related requirements concerning their products and any use of TI products in such safety-critical applications, notwithstanding any applications-related information or support that may be provided by TI. Further, Buyers must fully indemnify TI and its representatives against any damages arising out of the use of TI products in such safety-critical applications.

TI products are neither designed nor intended for use in military/aerospace applications or environments unless the TI products are specifically designated by TI as military-grade or "enhanced plastic." Only products designated by TI as military-grade meet military specifications. Buyers acknowledge and agree that any such use of TI products which TI has not designated as military-grade is solely at the Buyer's risk, and that they are solely responsible for compliance with all legal and regulatory requirements in connection with such use.

TI products are neither designed nor intended for use in automotive applications or environments unless the specific TI products are designated by TI as compliant with ISO/TS 16949 requirements. Buyers acknowledge and agree that, if they use any non-designated products in automotive applications, TI will not be responsible for any failure to meet such requirements.

Following are URLs where you can obtain information on other Texas Instruments products and application solutions:

Products

Amplifiers	amplifier.ti.com
Data Converters	dataconverter.ti.com
DLP® Products	www.dlp.com
DSP	dsp.ti.com
Clocks and Timers	www.ti.com/clocks
Interface	interface.ti.com
Logic	logic.ti.com
Power Mgmt	power.ti.com
Microcontrollers	microcontroller.ti.com
RFID	www.ti-rfid.com
RF/IF and ZigBee® Solutions	www.ti.com/lprf

Applications

Audio	www.ti.com/audio
Automotive	www.ti.com/automotive
Broadband	www.ti.com/broadband
Digital Control	www.ti.com/digitalcontrol
Medical	www.ti.com/medical
Military	www.ti.com/military
Optical Networking	www.ti.com/opticalnetwork
Security	www.ti.com/security
Telephony	www.ti.com/telephony
Video & Imaging	www.ti.com/video
Wireless	www.ti.com/wireless

Mailing Address: Texas Instruments, Post Office Box 655303, Dallas, Texas 75265
Copyright © 2009, Texas Instruments Incorporated