

# CC2642R SimpleLink™ Bluetooth® 5 low energy Wireless MCU

## 1 Device Overview

### 1.1 Features

- Microcontroller
  - Powerful Arm® Cortex®-M4F Processor
  - EEMBC CoreMark® Score: 148
  - Clock Speed Up to 48 MHz
  - 352KB of In-System Programmable Flash
  - 256KB of ROM for Protocols and Firmware
  - 8KB of Cache SRAM (Available as General-Purpose RAM)
  - 80KB of Ultra-Low Leakage SRAM
  - 2-Pin cJTAG and JTAG Debugging
  - Supports Over-the-Air Upgrade (OTA)
- Ultra-Low Power Sensor Controller With 4KB of SRAM
  - Sample, Store, and Process Sensor Data
  - Operation Independent From System CPU
  - Fast Wake-Up for Low-Power Operation
- TI-RTOS, Drivers, Bootloader, Bluetooth® 5 low energy Controller, and IEEE 802.15.4 MAC in ROM for Optimized Application Size
- TI-RTOS, Drivers, Bootloader, Bluetooth 5 low energy Controller in ROM for Optimized Application Size
- RoHS-Compliant Package
  - 7-mm x 7-mm RGZ VQFN48 (31 GPIOs)
- Peripherals
  - Digital Peripherals Can be Routed to Any GPIO
  - 4x 32-Bit or 8x 16-Bit General-Purpose Timers
  - 12-Bit ADC, 200 kSamples/s, 8 Channels
  - 2x Comparators With Internal Reference DAC (1x Continuous Time, 1x Ultra-Low Power)
  - Programmable Current Source
  - 2x UART
  - 2x SSI (SPI, MICROWIRE, TI)
  - I<sup>2</sup>C
  - I<sup>2</sup>S
  - Real-Time Clock (RTC)
  - AES 128- and 256-bit Crypto Accelerator
  - ECC and RSA Public Key Hardware Accelerator
  - SHA2 Accelerator (Full Suite Up to SHA-512)
  - True Random Number Generator (TRNG)
  - Capacitive Sensing, Up to 8 Channels
  - Integrated Temperature and Battery Monitor
- External System
  - On-Chip Buck DC/DC Converter
- Low Power
  - Wide Supply Voltage Range: 1.8 V to 3.8 V
  - Active-Mode RX: 6.9 mA
  - Active-Mode TX: 6.3 mA
  - Active-Mode MCU 48 MHz (CoreMark): 3.32 mA (69 µA/MHz)
  - Sensor Controller 16-Hz Flow Metering: 1.7 µA
  - Sensor Controller 100-Hz Comp A Reading: 1.5 µA
  - Sensor Controller, 1-Hz ADC Sampling: 1 µA
  - Standby: 0.9 µA (RTC on, 80KB RAM and CPU Retention)
  - Shutdown: 105 nA (Wakeup on External Events)
- Radio Section
  - 2.4-GHz RF Transceiver Compatible With Bluetooth 5 low energy
  - Excellent Receiver Sensitivity:
    - -103 dBm for Bluetooth 5 low energy Coded,
    - -97 dBm for 1-Mbps PHY
  - Programmable Output Power Up to +5 dBm
  - Suitable for Systems Targeting Compliance With Worldwide Radio Frequency Regulations
    - EN 300 328, (Europe)
    - EN 300 440 Class 2 (Europe)
    - FCC CFR47 Part 15 (US)
    - ARIB STD-T66 (Japan)
- Development [Tools and Software](#)
  - LAUNCHXL-CC26X2R1 Development Kit
  - SimpleLink CC26X2 Software Development Kit
  - SmartRF™ Software Studio for Simple Radio Configuration
  - Sensor Controller Studio for Building Low-Power Sensor Applications



## 1.2 Applications

- Consumer Electronics
- Mobile Phone Accessories
- Sports and Fitness Equipment
- HID Applications
- Medical
- Smart Grid and Automatic Meter Reading
- Home and Building Automation
- Wireless Alarm and Security Systems
- Industrial Monitoring and Control
- Wireless Healthcare Applications
- Wireless Sensor Networks
- Active RFID
- Energy Harvesting Applications
- Electronic Shelf Label (ESL)
- Long-Range Sensor Applications

## 1.3 Description

The CC2642R device is a wireless MCU targeting Bluetooth 4 and 5 low energy applications.

CC2642R is a member of the CC26xx and CC13xx family of cost-effective, ultra-low power, 2.4-GHz and Sub-1 GHz RF devices. Very low active RF and microcontroller (MCU) current, in addition to sub- $\mu$ A sleep current with up to 80KB of RAM retention, provide excellent battery lifetime and allow operation on small coin-cell batteries and in energy-harvesting applications.

The CC2642R device combines a flexible, very low-power [RF transceiver](#) with a powerful 48-MHz Arm<sup>®</sup> Cortex<sup>®</sup>-M4F CPU in a platform supporting multiple physical layers and RF standards. A dedicated Radio Controller (Arm<sup>®</sup> Cortex<sup>®</sup>-M0) handles low-level RF protocol commands that are stored in ROM or RAM, thus ensuring ultra-low power and great flexibility. The low power consumption of the CC2642R device does not come at the expense of RF performance; the CC2642R device has excellent sensitivity and robustness (selectivity and blocking) performance.

The CC2642R device is a highly integrated, true single-chip solution incorporating a complete RF system and an on-chip DC/DC converter.

Sensors can be handled in a very low-power manner by a programmable, autonomous ultra-low power Sensor Controller CPU with 4KB of SRAM for program and data. The Sensor Controller, with its fast wake-up and ultra-low-power 2-MHz mode is designed for sampling, buffering, and processing both analog and digital sensor data; thus the MCU system can maximize sleep time and reduce active power.

The CC2642R device is part of the SimpleLink<sup>™</sup> microcontroller (MCU) platform, which consists of Wi-Fi<sup>®</sup>, Bluetooth<sup>®</sup> low energy, Thread, Zigbee, Sub-1 GHz MCUs, and host MCUs, which all share a common, easy-to-use development environment with a single core software development kit (SDK) and rich tool set. A one-time integration of the SimpleLink platform enables you to add any combination of the portfolio's devices into your design, allowing 100 percent code reuse when your design requirements change. For more information, visit [ti.com/simplelink](http://ti.com/simplelink).

**Device Information<sup>(1)</sup>**

PART NUMBER	PACKAGE	BODY SIZE (NOM)
CC2642R1FRGZ	VQFN (48)	7.00 mm x 7.00 mm

(1) For more information, see [Section 9](#).

### 1.4 Functional Block Diagram

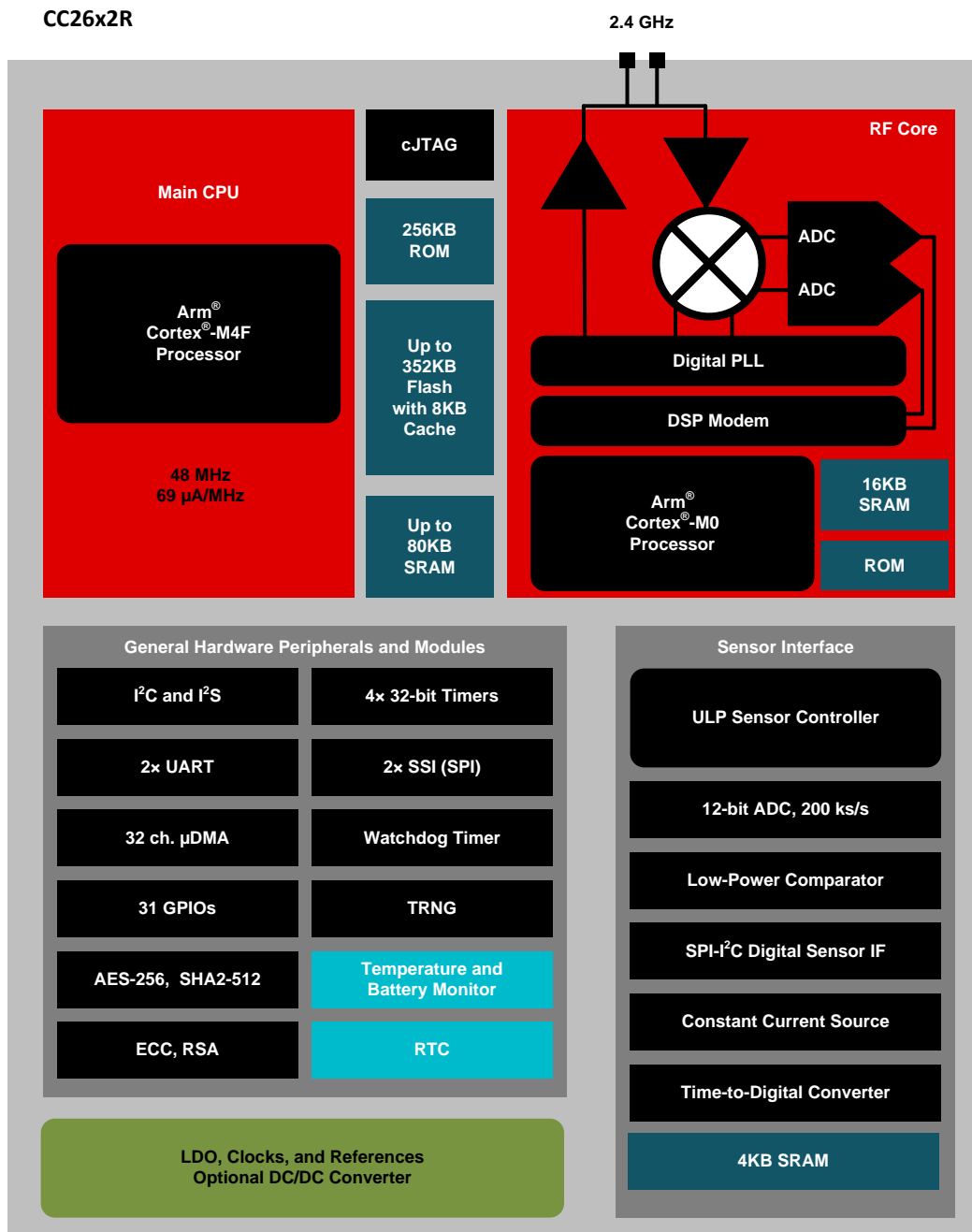

Copyright © 2018, Texas Instruments Incorporated

Figure 1-1. CC2642R Block Diagram

ADVANCE INFORMATION

## Table of Contents

<b>1 Device Overview</b> .....	<b><a href="#">1</a></b>	6.2 Functional Block Diagram .....	<b><a href="#">23</a></b>
1.1 Features .....	<a href="#">1</a>	6.3 System CPU .....	<a href="#">24</a>
1.2 Applications .....	<a href="#">2</a>	6.4 Radio (RF Core) .....	<a href="#">25</a>
1.3 Description .....	<a href="#">2</a>	6.5 Memory .....	<a href="#">26</a>
1.4 Functional Block Diagram .....	<a href="#">3</a>	6.6 Sensor Controller .....	<a href="#">27</a>
<b>2 Revision History</b> .....	<b><a href="#">4</a></b>	6.7 Cryptography .....	<a href="#">28</a>
<b>3 Device Comparison</b> .....	<b><a href="#">5</a></b>	6.8 Timers .....	<a href="#">29</a>
<b>4 Terminal Configuration and Functions</b> .....	<b><a href="#">6</a></b>	6.9 Serial Peripherals and I/O .....	<a href="#">30</a>
4.1 Pin Diagram – RGZ Package (Top Side View) .....	<a href="#">6</a>	6.10 Battery and Temperature Monitor .....	<a href="#">30</a>
4.2 Signal Descriptions – RGZ Package .....	<a href="#">7</a>	6.11 $\mu$ DMA .....	<a href="#">30</a>
4.3 Connections for Unused Pins .....	<a href="#">8</a>	6.12 Debug .....	<a href="#">30</a>
<b>5 Specifications</b> .....	<b><a href="#">9</a></b>	6.13 Power Management .....	<a href="#">31</a>
5.1 Absolute Maximum Ratings .....	<a href="#">9</a>	6.14 Clock Systems .....	<a href="#">32</a>
5.2 ESD Ratings .....	<a href="#">9</a>	6.15 Network Processor .....	<a href="#">32</a>
5.3 Recommended Operating Conditions .....	<a href="#">9</a>	<b>7 Application, Implementation, and Layout</b> .....	<b><a href="#">33</a></b>
5.4 Power Consumption – Power Modes .....	<a href="#">10</a>	7.1 LaunchPad™ Development Kit Reference Design .....	<a href="#">33</a>
5.5 Power Consumption — Radio Modes .....	<a href="#">11</a>	<b>8 Device and Documentation Support</b> .....	<b><a href="#">34</a></b>
5.6 Nonvolatile (Flash) Memory Characteristics .....	<a href="#">11</a>	8.1 Tools and Software .....	<a href="#">34</a>
5.7 Bluetooth low energy — Receive (RX) .....	<a href="#">12</a>	8.2 Documentation Support .....	<a href="#">36</a>
5.8 Bluetooth low energy — Transmit (TX) .....	<a href="#">14</a>	8.3 Community Resources .....	<a href="#">36</a>
5.9 Thermal Resistance Characteristics .....	<a href="#">14</a>	8.4 Trademarks .....	<a href="#">37</a>
5.10 Timing and Switching Characteristics .....	<a href="#">14</a>	8.5 Electrostatic Discharge Caution .....	<a href="#">37</a>
5.11 Peripheral Characteristics .....	<a href="#">18</a>	8.6 Glossary .....	<a href="#">37</a>
5.12 Typical Performance Curves .....	<a href="#">22</a>	<b>9 Mechanical, Packaging, and Orderable Information</b> .....	<b><a href="#">37</a></b>
<b>6 Detailed Description</b> .....	<b><a href="#">23</a></b>	9.1 Packaging Information .....	<a href="#">37</a>
6.1 Overview .....	<a href="#">23</a>		

## 2 Revision History

DATE	REVISION	NOTES
January 2018	SWRS194 *	Initial Release

ADVANCE INFORMATION

### 3 Device Comparison

**Table 3-1. Device Family Overview**

DEVICE	RADIO SUPPORT	FLASH (KB)	RAM (KB)	GPIO	PACKAGE SIZE
CC1312R	Sub-1 GHz	352	80	30	RGZ (7-mm x 7-mm VQFN48)
CC1352P	Dual-band (2.4- and Sub-1 GHz) Multiprotocol +20-dBm high-power amplifier	352	80	26	RGZ (7-mm x 7-mm VQFN48)
CC1352R	Dual-band (2.4- and Sub-1 GHz) Multiprotocol	352	80	28	RGZ (7-mm x 7-mm VQFN48)
CC2642R	Bluetooth 5 low energy 2.4-GHz proprietary FSK-based formats	352	80	31	RGZ (7-mm x 7-mm VQFN48)
CC2652R	Multiprotocol Bluetooth 5 low energy Zigbee Thread 2.4-GHz proprietary FSK-based formats	352	80	31	RGZ (7-mm x 7-mm VQFN48)
CC1310	Sub-1 GHz	32–128	16–20	10–31	RGZ (7-mm x 7-mm VQFN48) RHB (5-mm x 5-mm VQFN32) RSM (4-mm x 4-mm VQFN32)
CC1350	Sub-1 GHz Bluetooth 5 low energy	128	20	10–31	RGZ (7-mm x 7-mm VQFN48) RHB (5-mm x 5-mm VQFN32) RSM (4-mm x 4-mm VQFN32)
CC2640R2	Bluetooth 5 low energy 2.4-GHz proprietary FSK-based formats	128	20	10–31	RGZ (7-mm x 7-mm VQFN48) RHB (5-mm x 5-mm VQFN32) RSM (4-mm x 4-mm VQFN32) YFV (2.7-mm x 2.7-mm DSBGA34)

## 4 Terminal Configuration and Functions

### 4.1 Pin Diagram – RGZ Package (Top Side View)

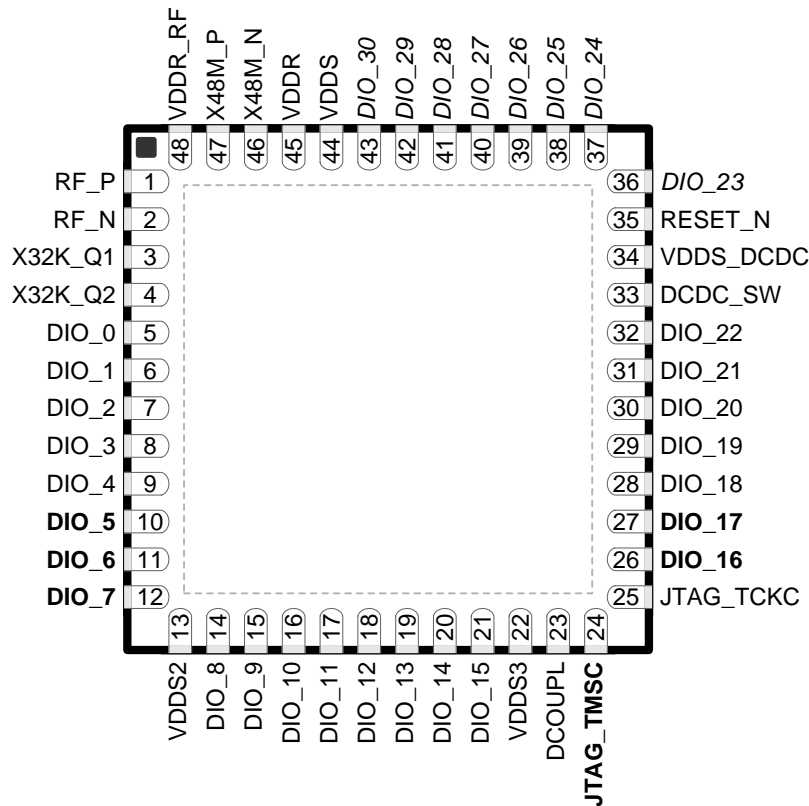

Figure 4-1. RGZ (7-mm × 7-mm) Pinout, 0.5-mm Pitch

I/O pins marked in [Figure 4-1](#) in bold have high-drive capabilities; they are the following:

- Pin 10, DIO\_5
- Pin 11, DIO\_6
- Pin 12, DIO\_7
- Pin 24, JTAG\_TMSC
- Pin 26, DIO\_16
- Pin 27, DIO\_17

I/O pins marked in [Figure 4-1](#) in *italics* have analog capabilities; they are the following:

- Pin 36, DIO\_23
- Pin 37, DIO\_24
- Pin 38, DIO\_25
- Pin 39, DIO\_26
- Pin 40, DIO\_27
- Pin 41, DIO\_28
- Pin 42, DIO\_29
- Pin 43, DIO\_30

## 4.2 Signal Descriptions – RGZ Package

**Table 4-1. Signal Descriptions – RGZ Package**

PIN		TYPE	DESCRIPTION
NAME	NO.		
DCDC_SW	33	Power	Output from internal DC/DC converter <sup>(1)</sup>
DCOUP_L	23	Power	1.27-V regulated digital-supply (decoupling capacitor) <sup>(2)</sup>
DIO_0	5	Digital I/O	GPIO, Sensor Controller
DIO_1	6	Digital I/O	GPIO, Sensor Controller
DIO_2	7	Digital I/O	GPIO, Sensor Controller
DIO_3	8	Digital I/O	GPIO, Sensor Controller
DIO_4	9	Digital I/O	GPIO, Sensor Controller
DIO_5	10	Digital I/O	GPIO, Sensor Controller, high-drive capability
DIO_6	11	Digital I/O	GPIO, Sensor Controller, high-drive capability
DIO_7	12	Digital I/O	GPIO, Sensor Controller, high-drive capability
DIO_8	14	Digital I/O	GPIO
DIO_9	15	Digital I/O	GPIO
DIO_10	16	Digital I/O	GPIO
DIO_11	17	Digital I/O	GPIO
DIO_12	18	Digital I/O	GPIO
DIO_13	19	Digital I/O	GPIO
DIO_14	20	Digital I/O	GPIO
DIO_15	21	Digital I/O	GPIO
DIO_16	26	Digital I/O	GPIO, JTAG_TDO, high-drive capability
DIO_17	27	Digital I/O	GPIO, JTAG_TDI, high-drive capability
DIO_18	28	Digital I/O	GPIO
DIO_19	29	Digital I/O	GPIO
DIO_20	30	Digital I/O	GPIO
DIO_21	31	Digital I/O	GPIO
DIO_22	32	Digital I/O	GPIO
DIO_23	36	Digital or Analog I/O	GPIO, Sensor Controller, analog
DIO_24	37	Digital or Analog I/O	GPIO, Sensor Controller, analog
DIO_25	38	Digital or Analog I/O	GPIO, Sensor Controller, analog
DIO_26	39	Digital or Analog I/O	GPIO, Sensor Controller, analog
DIO_27	40	Digital or Analog I/O	GPIO, Sensor Controller, analog
DIO_28	41	Digital or Analog I/O	GPIO, Sensor Controller, analog
DIO_29	42	Digital or Analog I/O	GPIO, Sensor Controller, analog
DIO_30	43	Digital or Analog I/O	GPIO, Sensor Controller, analog
EGP	—	GND	Ground – exposed ground pad
JTAG_TM_S_C	24	Digital I/O	JTAG TM_S_C, high-drive capability
JTAG_TCK_C	25	Digital I/O	JTAG TCK_C
RESET_N	35	Digital input	Reset, active low. No internal pullup resistor
RF_P	1	RF I/O	Positive RF input signal to LNA during RX Positive RF output signal from PA during TX
RF_N	2	RF I/O	Negative RF input signal to LNA during RX Negative RF output signal from PA during TX
VDDR	45	Power	1.7-V to 1.95-V supply, typically connect to output of internal DC/DC converter <sup>(3)(2)</sup>

(1) For more details, see technical reference manual listed in [Section 8.2](#).

(2) Do not supply external circuitry from this pin.

(3) If internal DC/DC converter is not used, this pin is supplied internally from the main LDO.

**Table 4-1. Signal Descriptions – RGZ Package (continued)**

PIN		TYPE	DESCRIPTION
NAME	NO.		
VDDR_RF	48	Power	1.7-V to 1.95-V supply, typically connect to output of internal DC/DC converter <sup>(4)(2)</sup>
VDDS	44	Power	1.8-V to 3.8-V main chip supply <sup>(1)</sup>
VDDS2	13	Power	1.8-V to 3.8-V DIO supply <sup>(1)</sup>
VDDS3	22	Power	1.8-V to 3.8-V DIO supply <sup>(1)</sup>
VDDS_DCDC	34	Power	1.8-V to 3.8-V DC/DC converter supply
X48M_N	46	Analog I/O	48-MHz crystal oscillator pin 1
X48M_P	47	Analog I/O	48-MHz crystal oscillator pin 2
X32K_Q1	3	Analog I/O	32-kHz crystal oscillator pin 1
X32K_Q2	4	Analog I/O	32-kHz crystal oscillator pin 2

(4) If internal DC/DC converter is not used, this pin must be connected to VDDR for supply from the main LDO.

### 4.3 Connections for Unused Pins

**Table 4-2. Connections for Unused Pins<sup>(1)</sup>**

FUNCTION	SIGNAL NAME	PIN NUMBER	ACCEPTABLE PRACTICE	PREFERRED PRACTICE
GPIO	DIO_n	5–12 14–21 26–32 36–43	NC	GND
32.768-kHz crystal	X32K_Q1 X32K_Q2	3–4	NC	NC
DC/DC converter <sup>(2)</sup>	DCDC_SW	33	NC	NC
	VDDR	45	Connect to VDDR_RF	Connect to VDDR_RF
	VDDR_RF	48	Connect to VDDR	Connect to VDDR
	VDDS_DCDC	34	Connect to VDDS	Connect to VDDS

(1) NC = No connect

(2) When the DC/DC converter is not used, the inductor between DCDC\_SW and VDDR can be removed. However, the VDDR decoupling capacitor must still be connected as shown in reference designs.



## 5 Specifications

### 5.1 Absolute Maximum Ratings

over operating free-air temperature range (unless otherwise noted)<sup>(1)(2)</sup>

		MIN	MAX	UNIT
V <sub>DD</sub> <sup>(3)</sup>	Supply voltage	-0.3	4.1	V
	Voltage on any digital pin <sup>(4)</sup>	-0.3	V <sub>DD</sub> + 0.3, max 4.1	V
	Voltage on crystal oscillator pins, X32K_Q1, X32K_Q2, X48M_N and X48M_P	-0.3	V <sub>DD</sub> R + 0.3, max 2.25	V
V <sub>in</sub>	Voltage on ADC input	Voltage scaling enabled	V <sub>DD</sub> S	V
		Voltage scaling disabled, internal reference	1.49	
		Voltage scaling disabled, V <sub>DD</sub> S as reference	V <sub>DD</sub> S / 2.9	
Input level, RF pins		5		dBm
T <sub>stg</sub>	Storage temperature	-40	150	°C

- (1) Stresses beyond those listed under *Absolute Maximum Ratings* may cause permanent damage to the device. These are stress ratings only, and functional operation of the device at these or any other conditions beyond those indicated under *Recommended Operating Conditions* is not implied. Exposure to absolute-maximum-rated conditions for extended periods may affect device reliability.
- (2) All voltage values are with respect to ground, unless otherwise noted.
- (3) V<sub>DD</sub>S2 and V<sub>DD</sub>S3 must be at the same potential as V<sub>DD</sub>S.
- (4) Including analog capable DIO.

### 5.2 ESD Ratings

			VALUE	UNIT	
V <sub>ESD</sub>	Electrostatic discharge	Human body model (HBM), per ANSI/ESDA/JEDEC JS001 <sup>(1)</sup>	X48_N X48_P	±3000	V
			All other pins	±3000	V
	Charged device model (CDM), per JESD22-C101		X48_N X48_P	±500	V
			All other pins	±500	V

- (1) JEDEC document JEP155 states that 500-V HBM allows safe manufacturing with a standard ESD control process.

### 5.3 Recommended Operating Conditions

over operating free-air temperature range (unless otherwise noted)

		MIN	MAX	UNIT
Ambient temperature		-40	85	°C
Operating supply voltage (V <sub>DD</sub> S)	For operation in battery-powered and 3.3-V systems (internal DC/DC can be used to minimize power consumption)	1.8	3.8	V
Rising supply voltage slew rate		0	100	mV/μs
Falling supply voltage slew rate <sup>(1)</sup>		0	20	mV/μs
Positive temperature gradient in Standby <sup>(2)</sup>	No limitation for negative temperature gradient, or outside standby mode	5		°C/s

- (1) For small coin-cell batteries, with high worst-case end-of-life equivalent source resistance, a 22-μF V<sub>DD</sub>S input capacitor must be used to ensure compliance with this slew rate.
- (2) Applications using RCOSC\_LF as sleep timer must also consider the drift in frequency caused by a change in temperature (see [Table 5-7](#)).

## 5.4 Power Consumption – Power Modes

Measured on a Texas Instruments reference design with  $T_c = 25^\circ\text{C}$ ,  $V_{\text{DD5}} = 3.0\text{ V}$  with DC/DC enabled unless otherwise noted.

PARAMETER		TEST CONDITIONS	TYP	UNIT
$I_{\text{core}}$ Core current consumption	Reset and Shutdown	Reset. RESET_N pin asserted or VDD5 below power-on-reset threshold	100	nA
		Shutdown. No clocks running, no retention	105	
	Standby without cache retention	RTC running, CPU, 80KB RAM and (partial) register retention. RCOSC_LF	0.9	$\mu\text{A}$
		RTC running, CPU, 80KB RAM and (partial) register retention. XOSC_LF	0.99	
	Standby with cache retention	RTC running, CPU, 80KB RAM and (partial) register retention. RCOSC_LF	2.82	$\mu\text{A}$
		RTC running, CPU, 80KB RAM and (partial) register retention. XOSC_LF	2.94	
	Idle	Supply Systems and RAM powered	661	$\mu\text{A}$
	Active	MCU running CoreMark at 48 MHz	3.32	mA
PERIPHERAL CURRENT CONSUMPTION <sup>(1)(2)</sup>				
$I_{\text{peri}}$	Peripheral power domain	Delta current with domain enabled		$\mu\text{A}$
	Serial power domain	Delta current with domain enabled		
	RF Core	Delta current with power domain enabled, clock enabled, RF core idle		
	$\mu\text{DMA}$	Delta current with clock enabled, module is idle		
	Timers	Delta current with clock enabled, module is idle		
	I2C	Delta current with clock enabled, module is idle		
	I2S	Delta current with clock enabled, module is idle		
	SSI	Delta current with clock enabled, module is idle		
	UART	Delta current with clock enabled, module is idle		
CRYPTO	Delta current with clock enabled, module is idle			

(1) Adds to core current  $I_{\text{core}}$  for each peripheral unit activated.

(2)  $I_{\text{peri}}$  is not supported in Standby or Shutdown modes.

## 5.5 Power Consumption — Radio Modes

Measured on a Texas Instruments reference design with  $T_c = 25^\circ\text{C}$ ,  $V_{\text{DD5}} = 3.0\text{ V}$  with DC/DC enabled unless otherwise noted.

PARAMETER	TEST CONDITIONS	TYP	UNIT
Radio receive current	2440 MHz	6.9	mA
Radio transmit current	0-dBm output power 2440 MHz	6.3	mA
	+5-dBm output power 2440 MHz	9.3	mA

## 5.6 Nonvolatile (Flash) Memory Characteristics

over operating free-air temperature range and  $V_{\text{DD5}} = 3.0\text{ V}$  (unless otherwise noted)

PARAMETER	TEST CONDITIONS	MIN	TYP	MAX	UNIT
Flash sector size			8		KB
Supported flash erase cycles before failure, full bank		30			k Cycles
Supported flash erase cycles before failure, single sector		100			k Cycles
Maximum number of write operations per row before sector erase <sup>(1)</sup>				83	write operations
Flash retention	105 °C	11.4			years at 105 °C
Flash sector erase current	Average delta current		12.6		mA
Flash sector erase time <sup>(2)</sup>			8		ms
Flash write current	Average delta current, 4 bytes at a time		8.15		mA
Flash write time <sup>(2)</sup>	4 bytes at a time		8		µs

- (1) Each row is 2048 bits (or 256 bytes) wide. This limitation corresponds to sequential memory writes of 4 (3.1) bytes minimum per write over a whole flash sector before a sector erase is required.
- (2) This number is dependent on Flash aging and increases over time and erase cycles.

## 5.7 Bluetooth low energy — Receive (RX)

Measured on a Texas Instruments reference design with  $T_c = 25^\circ\text{C}$ ,  $V_{\text{DD5}} = 3.0\text{ V}$  with

DC/DC enabled unless otherwise noted. All measurements are done at the antenna input with a combined RX and TX path.

PARAMETER	TEST CONDITIONS	MIN	TYP	MAX	UNIT
<b>1-Mbps 2-GFSK (Bluetooth 4 and Bluetooth 5 low energy)</b>					
Receiver sensitivity	Differential mode. BER = $10^{-3}$		-97		dBm
Receiver saturation	Differential mode. BER = $10^{-3}$		4		dBm
Frequency error tolerance	Difference between the incoming carrier frequency and the internally generated carrier frequency	-350		350	kHz
Data rate error tolerance	Difference between incoming data rate and the internally generated data rate	-750		750	ppm
Co-channel rejection <sup>(1)</sup>	Wanted signal at -67 dBm, modulated interferer in channel, BER = $10^{-3}$		-6		dB
Selectivity, $\pm 1\text{ MHz}$ <sup>(1)</sup>	Wanted signal at -67 dBm, modulated interferer at $\pm 1\text{ MHz}$ , BER = $10^{-3}$		7 / 3 <sup>(2)</sup>		dB
Selectivity, $\pm 2\text{ MHz}$ <sup>(1)</sup>	Wanted signal at -67 dBm, modulated interferer at $\pm 2\text{ MHz}$ , BER = $10^{-3}$		34 / 25 <sup>(2)</sup>		dB
Selectivity, $\pm 3\text{ MHz}$ <sup>(1)</sup>	Wanted signal at -67 dBm, modulated interferer at $\pm 3\text{ MHz}$ , BER = $10^{-3}$		38 / 26 <sup>(2)</sup>		dB
Selectivity, $\pm 4\text{ MHz}$ <sup>(1)</sup>	Wanted signal at -67 dBm, modulated interferer at $\pm 4\text{ MHz}$ , BER = $10^{-3}$		42 / 29 <sup>(2)</sup>		dB
Selectivity, $\pm 5\text{ MHz}$ or more <sup>(1)</sup>	Wanted signal at -67 dBm, modulated interferer at $\geq \pm 5\text{ MHz}$ , BER = $10^{-3}$		32		dB
Selectivity, Image frequency <sup>(1)</sup>	Wanted signal at -67 dBm, modulated interferer at image frequency, BER = $10^{-3}$		25		dB
Selectivity, Image frequency $\pm 1\text{ MHz}$ <sup>(1)</sup>	Wanted signal at -67 dBm, modulated interferer at $\pm 1\text{ MHz}$ from image frequency, BER = $10^{-3}$		3 / 26 <sup>(2)</sup>		dB
Out-of-band blocking <sup>(3)</sup>	30 MHz to 2000 MHz		-20		dBm
Out-of-band blocking	2003 MHz to 2399 MHz		-5		dBm
Out-of-band blocking	2484 MHz to 2997 MHz		-8		dBm
Out-of-band blocking	3000 MHz to 12.75 GHz		-8		dBm
Intermodulation	Wanted signal at 2402 MHz, -64 dBm. Two interferers at 2405 and 2408 MHz respectively, at the given power level		-34		dBm
Spurious emissions, 30 to 1000 MHz	Conducted measurement in a 50- $\Omega$ single-ended load. Suitable for systems targeting compliance with EN 300 328, EN 300 440 class 2, FCC CFR47, Part 15 and ARIB STD-T-66		-71		dBm
Spurious emissions, 1 to 12.75 GHz	Conducted measurement in a 50 $\Omega$ single-ended load. Suitable for systems targeting compliance with EN 300 328, EN 300 440 class 2, FCC CFR47, Part 15 and ARIB STD-T-66		-62		dBm
RSSI dynamic range			70		dB
RSSI accuracy					dB
<b>2-Mbps 2-GFSK (Bluetooth 5)</b>					
Receiver sensitivity	Differential mode. Measured at SMA connector, BER = $10^{-3}$		-92		dBm
Receiver saturation	Differential mode. Measured at SMA connector, BER = $10^{-3}$		4		dBm

(1) Numbers given as I/C dB.

(2) X / Y, where X is +N MHz and Y is -N MHz.

(3) Excluding one exception at  $F_{\text{wanted}} / 2$ , per Bluetooth Specification.

**Bluetooth low energy — Receive (RX) (continued)**

Measured on a Texas Instruments reference design with  $T_c = 25^\circ\text{C}$ ,  $V_{\text{DD5}} = 3.0\text{ V}$  with DC/DC enabled unless otherwise noted. All measurements are done at the antenna input with a combined RX and TX path.

PARAMETER	TEST CONDITIONS	MIN	TYP	MAX	UNIT
Frequency error tolerance	Difference between the incoming carrier frequency and the internally generated carrier frequency	-300		500	kHz
Data rate error tolerance	Difference between incoming data rate and the internally generated data rate	-1000		1000	ppm
Co-channel rejection <sup>(1)</sup>	Wanted signal at -67 dBm, modulated interferer in channel, BER = $10^{-3}$		-7		dB
Selectivity, $\pm 2\text{ MHz}$ <sup>(1)</sup>	Wanted signal at -67 dBm, modulated interferer at $\pm 2\text{ MHz}$ , Image frequency is at -2 MHz, BER = $10^{-3}$		8 / 4 <sup>(2)</sup>		dB
Selectivity, $\pm 4\text{ MHz}$ <sup>(1)</sup>	Wanted signal at -67 dBm, modulated interferer at $\pm 4\text{ MHz}$ , BER = $10^{-3}$		31 / 26 <sup>(2)</sup>		dB
Selectivity, $\pm 6\text{ MHz}$ <sup>(1)</sup>	Wanted signal at -67 dBm, modulated interferer at $\pm 6\text{ MHz}$ , BER = $10^{-3}$		37 / 38 <sup>(2)</sup>		dB
Alternate channel rejection, $\pm 7\text{ MHz}$ <sup>(1)</sup>	Wanted signal at -67 dBm, modulated interferer at $\geq \pm 7\text{ MHz}$ , BER = $10^{-3}$		37 / 36 <sup>(2)</sup>		dB
Selectivity, Image frequency <sup>(1)</sup>	Wanted signal at -67 dBm, modulated interferer at image frequency, BER = $10^{-3}$		4		dB
Selectivity, Image frequency $\pm 2\text{ MHz}$ <sup>(1)</sup>	Note that Image frequency + 2 MHz is the Co-channel. Wanted signal at -67 dBm, modulated interferer at $\pm 2\text{ MHz}$ from image frequency, BER = $10^{-3}$		-7 / 26 <sup>(2)</sup>		dB
Out-of-band blocking <sup>(3)</sup>	30 MHz to 2000 MHz		-33		dBm
Out-of-band blocking	2003 MHz to 2399 MHz		-15		dBm
Out-of-band blocking	2484 MHz to 2997 MHz		-12		dBm
Out-of-band blocking	3000 MHz to 12.75 GHz		-10		dBm
Intermodulation	Wanted signal at 2402 MHz, -64 dBm. Two interferers at 2405 and 2408 MHz respectively, at the given power level		-45		dBm
<b>500-kbps (Bluetooth 5 coded)</b>					
Receiver sensitivity	Differential mode. BER = $10^{-3}$				dBm
Receiver saturation	Differential mode. BER = $10^{-3}$				dBm
<b>125-kbps (Bluetooth 5 coded)</b>					
Receiver sensitivity	Differential mode. BER = $10^{-3}$				dBm
Receiver saturation	Differential mode. BER = $10^{-3}$				dBm

## 5.8 Bluetooth low energy — Transmit (TX)

Measured on a Texas Instruments reference design with  $T_c = 25^\circ\text{C}$ ,  $V_{\text{DD5}} = 3.0\text{ V}$ , DC/DC enabled

PARAMETER	TEST CONDITIONS	MIN	TYP	MAX	UNIT
<b>General Parameters</b>					
Max output power	Differential mode, delivered to a single-ended $50\ \Omega$ load through a balun		5		dBm
Min output power	Differential mode, delivered to a single-ended $50\ \Omega$ load through a balun		-21		dBm
Spurious emissions, conducted regular PA <sup>(1)</sup>	f < 1 GHz, outside restricted bands	+5-dBm setting	-43		dBm
	f < 1 GHz, restricted bands ETSI	+5-dBm setting	-65		dBm
	f < 1 GHz, restricted bands FCC	+5-dBm setting	-76		dBm
	f > 1 GHz, including harmonics	+5-dBm setting	-46		dBm

(1) Suitable for systems targeting compliance with worldwide radio-frequency regulations ETSI EN 300 328 and EN 300 440 Class 2 (Europe), FCC CFR47 Part 15 (US), and ARIB STD-T66 (Japan).

## 5.9 Thermal Resistance Characteristics

THERMAL METRIC <sup>(1)</sup>	CC2642R	UNIT <sup>(2)</sup>
	RGZ (VQFN)	
	48 PINS	
$R_{\theta\text{JA}}$ Junction-to-ambient thermal resistance	29.6	$^\circ\text{C/W}$
$R_{\theta\text{JC(top)}}$ Junction-to-case (top) thermal resistance	15.7	$^\circ\text{C/W}$
$R_{\theta\text{JB}}$ Junction-to-board thermal resistance	6.2	$^\circ\text{C/W}$
$\Psi_{\text{JT}}$ Junction-to-top characterization parameter	0.3	$^\circ\text{C/W}$
$\Psi_{\text{JB}}$ Junction-to-board characterization parameter	6.2	$^\circ\text{C/W}$
$R_{\theta\text{JC(bot)}}$ Junction-to-case (bottom) thermal resistance	1.9	$^\circ\text{C/W}$

(1) For more information about traditional and new thermal metrics, see [Semiconductor and IC Package Thermal Metrics](#).

(2)  $^\circ\text{C/W}$  = degrees Celsius per watt.

## 5.10 Timing and Switching Characteristics

**Table 5-1. Reset Timing**

	MIN	TYP	MAX	UNIT
RESET_N low duration	1			$\mu\text{s}$

**Table 5-2. Wakeup Timing**

Measured on a Texas Instruments reference design with  $T_c = 25^\circ\text{C}$ ,  $V_{\text{DD5}} = 3.0\text{ V}$ , unless otherwise noted. The times listed here do not include RTOS overhead.

PARAMETER	TEST CONDITIONS	MIN	TYP	MAX	UNIT
MCU, Idle → Active			14		$\mu\text{s}$
MCU, Standby → Active			100		$\mu\text{s}$
MCU, Shutdown → Active			1100		$\mu\text{s}$

### 5.10.1 Clock Specifications

**Table 5-3. 48-MHz Crystal Oscillator (XOSC\_HF)**

Measured on a Texas Instruments reference design with  $T_c = 25^\circ\text{C}$ ,  $V_{\text{DD5}} = 3.0\text{ V}$ , unless otherwise noted.<sup>(1)</sup>

	MIN	TYP	MAX	UNIT
Crystal frequency		48		MHz
ESR equivalent series resistance			60	$\Omega$
$L_M$ Motional inductance, relates to the load capacitance that is used for the crystal ( $C_L$ in Farads)		$< 0.5 \times 10^{-24} / C_L^2$		H
$C_L$ Crystal load capacitance <sup>(2)</sup>	5	7 <sup>(3)</sup>	9	pF
Start-up time <sup>(4)</sup>		250		$\mu\text{s}$

- (1) Probing or otherwise stopping the crystal while the DC/DC converter is enabled may cause permanent damage to the device.
- (2) Adjustable load capacitance is integrated into the device.
- (3) On-chip default connected capacitance including reference design parasitic capacitance. Connected internal capacitance is changed through software in the Customer Configuration section (CCFG)
- (4) The crystal start-up time is fast because it is "kick-started" using the RCOSC\_HF oscillator (temperature and aging compensated by default) that is running at the same frequency. This number will increase if disabling the calibration of RCOSC\_HF in the TI-provided power driver

**Table 5-4. 32.768-kHz Crystal Oscillator (XOSC\_LF)**

Measured on a Texas Instruments reference design with  $T_c = 25^\circ\text{C}$ ,  $V_{\text{DD5}} = 3.0\text{ V}$ , unless otherwise noted.<sup>(1)</sup>

	MIN	TYP	MAX	UNIT
Crystal frequency		32.768		kHz
ESR Equivalent series resistance		30	100	k $\Omega$
Internal crystal load capacitance ( $C_L$ )	6	7 <sup>(2)</sup>	12	pF

- (1) Probing or otherwise stopping the crystal while the DC/DC converter is enabled may cause permanent damage to the device.
- (2) Default load capacitance using TI reference designs including parasitic capacitance. Crystals with different load capacitance may be used.

**Table 5-5. 48-MHz RC Oscillator (RCOSC\_HF)**

Measured on a Texas Instruments reference design with  $T_c = 25^\circ\text{C}$ ,  $V_{\text{DD5}} = 3.0\text{ V}$ , unless otherwise noted.

	MIN	TYP	MAX	UNIT
Frequency		48		MHz
Uncalibrated frequency accuracy		$\pm 1\%$		
Calibrated frequency accuracy <sup>(1)</sup>		$\pm 0.25\%$		
Start-up time		5		$\mu\text{s}$

- (1) Accuracy relatively to the calibration source (XOSC\_HF).

**Table 5-6. 2-MHz RC Oscillator (RCOSC\_MF)**

Measured on a Texas Instruments reference design with  $T_c = 25^\circ\text{C}$ ,  $V_{\text{DD5}} = 3.0\text{ V}$ , unless otherwise noted.

	MIN	TYP	MAX	UNIT
Calibrated frequency		2		MHz
Temperature coefficient				ppm/ $^\circ\text{C}$
Start-up time				$\mu\text{s}$

**Table 5-7. 32-kHz RC Oscillator (RCOSC\_LF)**

Measured on the Texas Instruments CC1352PEM-7XD-7793 reference design with  $T_c = 25^\circ\text{C}$ ,  $V_{\text{DD5}} = 3.0\text{ V}$ , unless otherwise noted.

	MIN	TYP	MAX	UNIT
Calibrated frequency		32.768		kHz
Temperature coefficient		50		ppm/ $^\circ\text{C}$

### 5.10.2 Synchronous Serial Interface (SSI) Characteristics

**Table 5-8. Synchronous Serial Interface (SSI) Characteristics**

T<sub>c</sub> = 25°C, V<sub>DD5</sub> = 3.0 V, unless otherwise noted.

PARAMETER NO.	PARAMETER	MIN	TYP	MAX	UNIT
S1	t <sub>clk_per</sub> SSIClk cycle time	12		65024	system clocks
S2 <sup>(1)</sup>	t <sub>clk_high</sub> SSIClk high time		0.5		t <sub>clk_per</sub>
S3 <sup>(1)</sup>	t <sub>clk_low</sub> SSIClk low time		0.5		t <sub>clk_per</sub>

(1) Refer to SSI timing diagrams [Figure 5-1](#), [Figure 5-2](#), and [Figure 5-3](#).

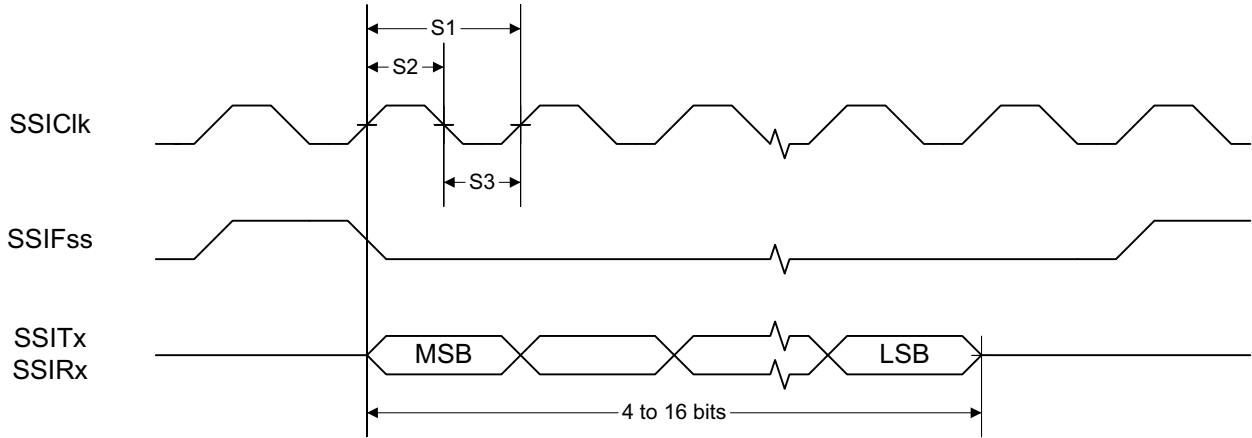

**Figure 5-1. SSI Timing for TI Frame Format (FRF = 01), Single Transfer Timing Measurement**

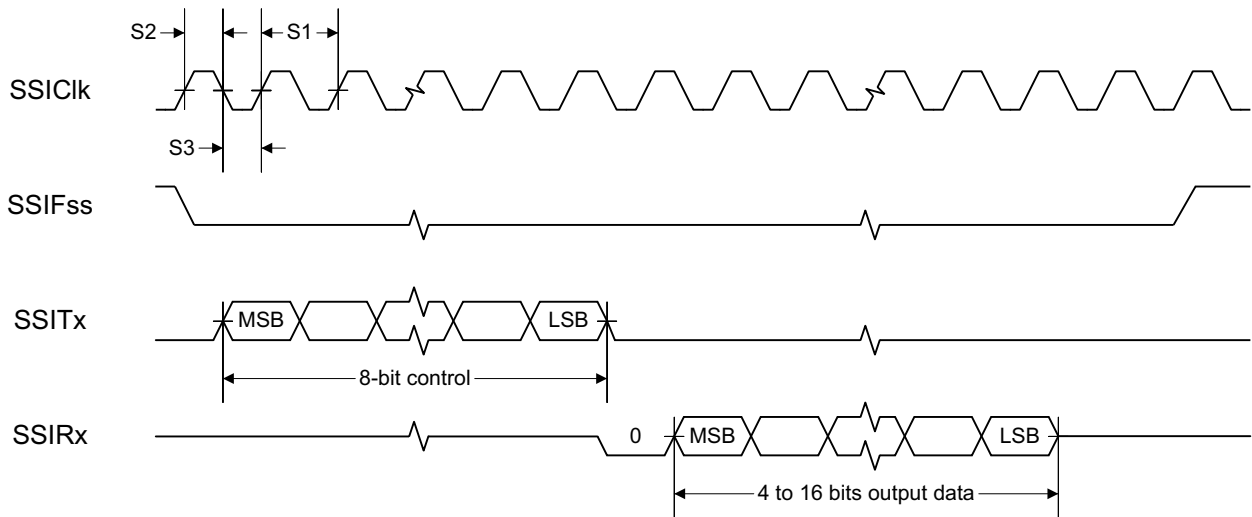

**Figure 5-2. SSI Timing for MICROWIRE Frame Format (FRF = 10), Single Transfer**

ADVANCE INFORMATION



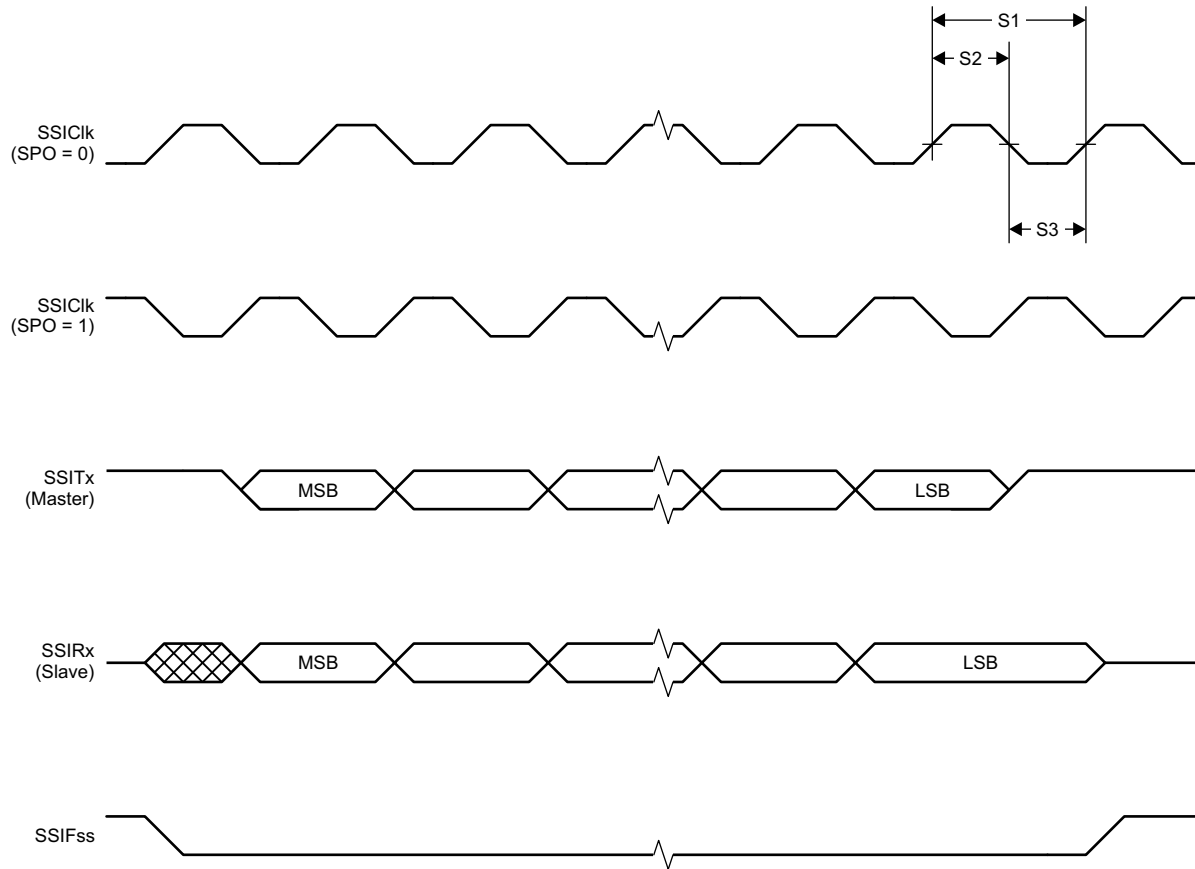

Figure 5-3. SSI Timing for SPI Frame Format (FRF = 00), With SPH = 1

## 5.11 Peripheral Characteristics

**Table 5-9. ADC Characteristics**

$T_c = 25^\circ\text{C}$ ,  $V_{\text{DD5}} = 3.0\text{ V}$  and voltage scaling enabled, unless otherwise noted.<sup>(1)</sup>

PARAMETER	TEST CONDITIONS	MIN	TYP	MAX	UNIT
Input voltage range		0		V <sub>DD5</sub>	V
Resolution			12		Bits
Sample rate				200	kSamples/s
Offset	Internal 4.3-V equivalent reference <sup>(2)</sup>		2		LSB
Gain error	Internal 4.3-V equivalent reference <sup>(2)</sup>		2.4		LSB
DNL <sup>(3)</sup> Differential nonlinearity			>-1		LSB
INL <sup>(4)</sup> Integral nonlinearity			±3		LSB
ENOB Effective number of bits	Internal 4.3-V equivalent reference <sup>(2)</sup> , 200 kSamples/s, 9.6-kHz input tone		9.8		Bits
	V <sub>DD5</sub> as reference, 200 kSamples/s, 9.6-kHz input tone		10		
	Internal 1.44-V reference, voltage scaling disabled, 32 samples average, 200 kSamples/s, 300-Hz input tone		11.1		
THD Total harmonic distortion	Internal 4.3-V equivalent reference <sup>(2)</sup> , 200 kSamples/s, 9.6-kHz input tone		-65		dB
	V <sub>DD5</sub> as reference, 200 kSamples/s, 9.6-kHz input tone		-69		
	Internal 1.44-V reference, voltage scaling disabled, 32 samples average, 200 kSamples/s, 300-Hz input tone		-71		
SINAD, SNDR Signal-to-noise and Distortion ratio	Internal 4.3-V equivalent reference <sup>(2)</sup> , 200 kSamples/s, 9.6-kHz input tone		60		dB
	V <sub>DD5</sub> as reference, 200 kSamples/s, 9.6-kHz input tone		63		
	Internal 1.44-V reference, voltage scaling disabled, 32 samples average, 200 kSamples/s, 300-Hz input tone		69		
SFDR Spurious-free dynamic range	Internal 4.3-V equivalent reference <sup>(2)</sup> , 200 kSamples/s, 9.6-kHz input tone		67		dB
	V <sub>DD5</sub> as reference, 200 kSamples/s, 9.6-kHz input tone		72		
	Internal 1.44-V reference, voltage scaling disabled, 32 samples average, 200 kSamples/s, 300-Hz input tone		73		
Conversion time	Serial conversion, time-to-output, 24-MHz clock		50		clock-cycles
Current consumption	Internal 4.3-V equivalent reference <sup>(2)</sup>		0.66		mA
Current consumption	V <sub>DD5</sub> as reference		0.75		mA
Reference voltage	Equivalent fixed internal reference (input voltage scaling enabled). For best accuracy, the ADC conversion should be initiated through the TI-RTOS API in order to include the gain/offset compensation factors stored in FCFG1.		4.3 <sup>(2)(5)</sup>		V

(1) Using IEEE Std 1241™-2010 for terminology and test methods.

(2) Input signal scaled down internally before conversion, as if voltage range was 0 to 4.3 V.

(3) No missing codes. Positive DNL typically varies from +0.3 to +3.5, depending on device (see [Figure 5-7](#)).

(4) For a typical example, see [Figure 5-6](#).

(5) Applied voltage must be within Absolute Maximum Ratings (see [Section 5.1](#)) at all times.

**Table 5-9. ADC Characteristics (continued)**
 $T_c = 25^\circ\text{C}$ ,  $V_{\text{DDS}} = 3.0\text{ V}$  and voltage scaling enabled, unless otherwise noted.<sup>(1)</sup>

PARAMETER	TEST CONDITIONS	MIN	TYP	MAX	UNIT
Reference voltage	Fixed internal reference (input voltage scaling disabled). For best accuracy, the ADC conversion should be initiated through the TI-RTOS API in order to include the gain/offset compensation factors stored in FCFG1. This value is derived from the scaled value (4.3 V) as follows: $V_{\text{ref}} = 4.3\text{ V} \times 1408 / 4095$		1.48		V
Reference voltage	VDDS as reference (Also known as <i>RELATIVE</i> ) (input voltage scaling enabled)		VDDS		V
Reference voltage	VDDS as reference (Also known as <i>RELATIVE</i> ) (input voltage scaling disabled)		VDDS / 2.82 <sup>(5)</sup>		V
Input impedance	200 kSamples/s, voltage scaling enabled. Capacitive input, Input impedance depends on sampling frequency and sampling time		>1		MΩ

**Table 5-10. Temperature Sensor**

Measured on the Texas Instruments CC1352PEM-7XD-7793 reference design with  $T_c = 25^\circ\text{C}$ ,  $V_{\text{DDS}} = 3.0\text{ V}$ , unless otherwise noted.

PARAMETER	TEST CONDITIONS	MIN	TYP	MAX	UNIT
Resolution					°C
Range		-40		85	°C
Accuracy					°C
Supply voltage coefficient <sup>(1)</sup>					°C/V

(1) Automatically compensated when using supplied driver libraries.

**Table 5-11. Battery Monitor**

Measured on the Texas Instruments CC1352PEM-7XD-7793 reference design with  $T_c = 25^\circ\text{C}$ ,  $V_{\text{DDS}} = 3.0\text{ V}$ , unless otherwise noted.

PARAMETER	TEST CONDITIONS	MIN	TYP	MAX	UNIT
Resolution					mV
Range		1.8		3.8	V
Accuracy					mV

**Table 5-12. Continuous Time Comparator**
 $T_c = 25^\circ\text{C}$ ,  $V_{\text{DDS}} = 3.0\text{ V}$ , unless otherwise noted.

PARAMETER	TEST CONDITIONS	MIN	TYP	MAX	UNIT
Input voltage range		0		$V_{\text{DDS}}$	V
External reference voltage		0		$V_{\text{DDS}}$	V
Internal reference voltage range					V
Internal reference voltage step size					
Offset					mV
Hysteresis					mV
Decision time	Step from -10 mV to 10 mV				μs
Current consumption when enabled <sup>(1)</sup>	Using external reference				μA
Current consumption when enabled <sup>(1)</sup>	Using internal reference				μA

(1) Additionally, the bias module must be enabled when running in standby mode.

**Table 5-13. Low-Power Clocked Comparator**

$T_c = 25^\circ\text{C}$ ,  $V_{\text{DD5}} = 3.0\text{ V}$ , unless otherwise noted.

PARAMETER	TEST CONDITIONS	MIN	TYP	MAX	UNIT
Input voltage range		0		$V_{\text{DD5}}$	V
Clock frequency			32.8		kHz
Internal reference voltage range					V
Internal reference voltage step size					V
Offset					mV
Hysteresis					mV
Decision time	Step from $-50\text{ mV}$ to $50\text{ mV}$		1		clock-cycle
Current consumption when enabled					nA

**Table 5-14. Programmable Current Source**

$T_c = 25^\circ\text{C}$ ,  $V_{\text{DD5}} = 3.0\text{ V}$ , unless otherwise noted.

PARAMETER	TEST CONDITIONS	MIN	TYP	MAX	UNIT
Current source programmable output range (logarithmic range)			0.25 to 20		$\mu\text{A}$
Resolution			0.25		$\mu\text{A}$
Current consumption <sup>(1)</sup>	Including current source at maximum programmable output		23		$\mu\text{A}$

(1) Additionally, the bias module must be enabled when running in standby mode.

**Table 5-15. GPIO DC Characteristics**

PARAMETER	TEST CONDITIONS	MIN	TYP	MAX	UNIT
<b><math>T_A = 25^\circ\text{C}</math>, <math>V_{\text{DD5}} = 1.8\text{ V}</math></b>					
GPIO VOH at 8-mA load	IOCURR = 2, high-drive GPIOs only	1.32	1.54		V
GPIO VOL at 8-mA load	IOCURR = 2, high-drive GPIOs only		0.26	0.32	V
GPIO VOH at 4-mA load	IOCURR = 1	1.32	1.58		V
GPIO VOL at 4-mA load	IOCURR = 1		0.21	0.32	V
GPIO pullup current	Input mode, pullup enabled, $V_{\text{pad}} = 0\text{ V}$		71.7		$\mu\text{A}$
GPIO pulldown current	Input mode, pulldown enabled, $V_{\text{pad}} = V_{\text{DD5}}$		21.1		$\mu\text{A}$
GPIO high/low input transition, no hysteresis	IH = 0, transition between reading 0 and reading 1		0.88		V
GPIO low-to-high input transition, with hysteresis	IH = 1, transition voltage for input read as 0 $\rightarrow$ 1		1.07		V
GPIO high-to-low input transition, with hysteresis	IH = 1, transition voltage for input read as 1 $\rightarrow$ 0		0.74		V
GPIO input hysteresis	IH = 1, difference between 0 $\rightarrow$ 1 and 1 $\rightarrow$ 0 points		0.33		V
<b><math>T_A = 25^\circ\text{C}</math>, <math>V_{\text{DD5}} = 3.0\text{ V}</math></b>					
GPIO VOH at 8-mA load	IOCURR = 2, high-drive GPIOs only		2.68		V
GPIO VOL at 8-mA load	IOCURR = 2, high-drive GPIOs only		0.33		V
GPIO VOH at 4-mA load	IOCURR = 1		2.72		V
GPIO VOL at 4-mA load	IOCURR = 1		0.28		V

**Table 5-15. GPIO DC Characteristics (continued)**

PARAMETER	TEST CONDITIONS	MIN	TYP	MAX	UNIT
<b>T<sub>A</sub> = 25°C, V<sub>DD5</sub> = 3.8 V</b>					
GPIO pullup current	Input mode, pullup enabled, V <sub>pad</sub> = 0 V		277		μA
GPIO pulldown current	Input mode, pulldown enabled, V <sub>pad</sub> = V <sub>DD5</sub>		113		μA
GPIO high/low input transition, no hysteresis	I <sub>H</sub> = 0, transition between reading 0 and reading 1		1.67		V
GPIO low-to-high input transition, with hysteresis	I <sub>H</sub> = 1, transition voltage for input read as 0 → 1		1.94		V
GPIO high-to-low input transition, with hysteresis	I <sub>H</sub> = 1, transition voltage for input read as 1 → 0		1.54		V
GPIO input hysteresis	I <sub>H</sub> = 1, difference between 0 → 1 and 1 → 0 points		0.4		V
V <sub>IH</sub>	Lowest GPIO input voltage reliably interpreted as a <i>High</i>			0.8	V <sub>DD5</sub> <sup>(1)</sup>
V <sub>IL</sub>	Highest GPIO input voltage reliably interpreted as a <i>Low</i>	0.2			V <sub>DD5</sub> <sup>(1)</sup>

(1) Each GPIO is referenced to a specific V<sub>DD5</sub> pin. See the technical reference manual listed in [Section 8.2](#) for more details.

### 5.12 Typical Performance Curves

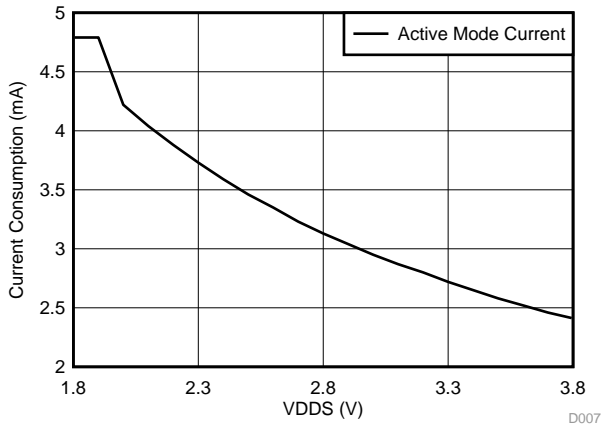

Figure 5-4. Active Mode (MCU) Current Consumption vs Supply Voltage (VDD5)

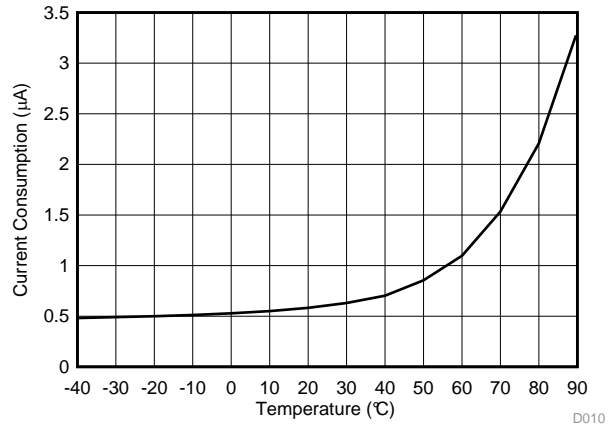

Figure 5-5. Standby MCU Current Consumption, 32 kHz Clock, RAM and MCU Retention

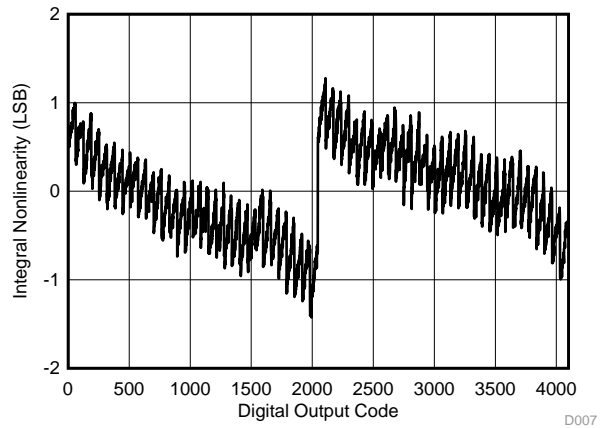

Figure 5-6. SoC ADC, Integral Nonlinearity vs Digital Output Code

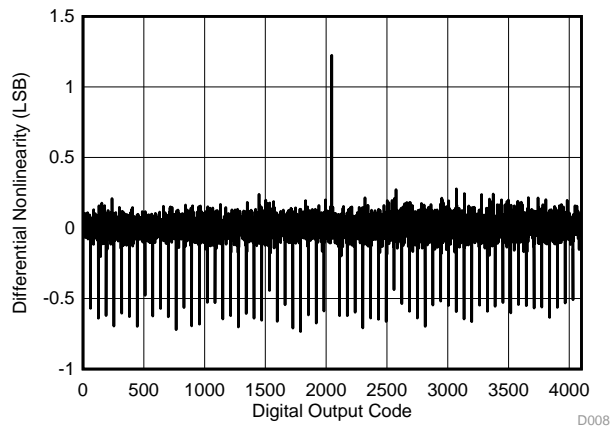

Figure 5-7. SoC ADC, Differential Nonlinearity vs Digital Output Code

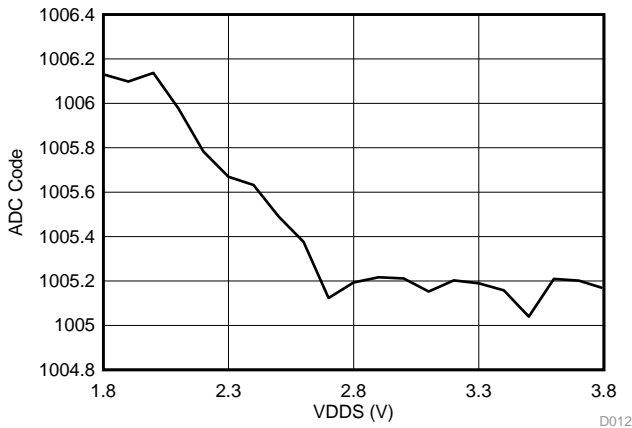

Figure 5-8. SoC ADC Output vs Supply Voltage (Fixed Input, Internal Reference, No Scaling)

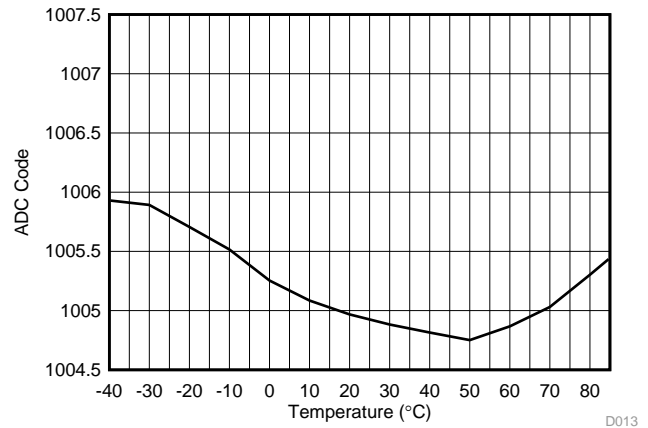

Figure 5-9. SoC ADC Output vs Temperature (Fixed Input, Internal Reference, No Scaling)

ADVANCE INFORMATION

## 6 Detailed Description

### 6.1 Overview

Section 6.2 shows the core modules of the CC2642R device.

### 6.2 Functional Block Diagram

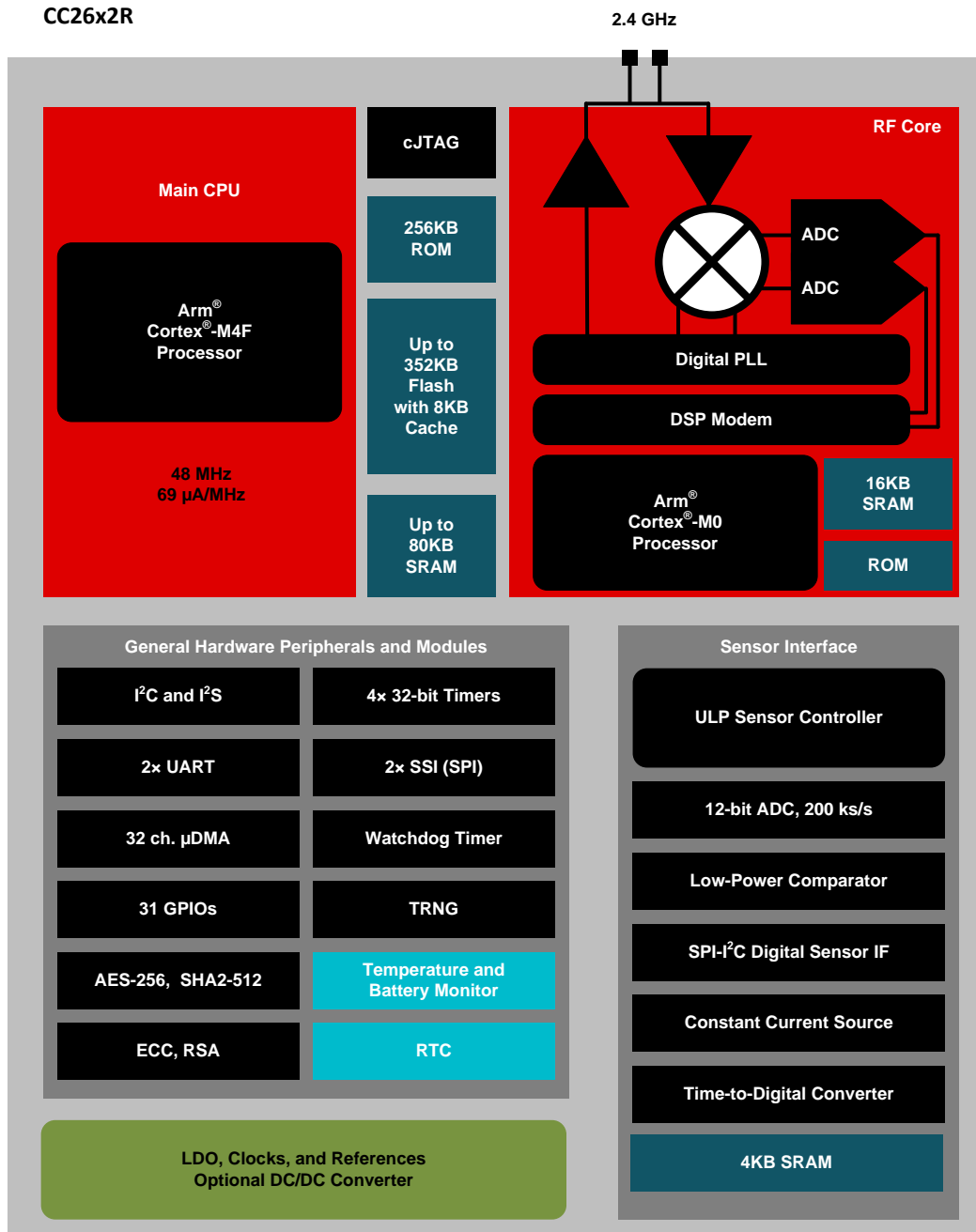

Copyright © 2018, Texas Instruments Incorporated

Figure 6-1. CC2642R Block Diagram

ADVANCE INFORMATION

### 6.3 System CPU

The CC2642R SimpleLink Wireless MCU contains an Arm Cortex-M4F system CPU, which runs the application and the higher layers of radio protocol stacks.

The system CPU is the foundation of a high-performance, low-cost platform that meets the system requirements of minimal memory implementation, and low-power consumption, while delivering outstanding computational performance and exceptional system response to interrupts.

Its features include the following:

- ARMv7-M architecture optimized for small-footprint embedded applications
- Arm Thumb<sup>®</sup>-2 mixed 16- and 32-bit instruction set delivers the high performance expected of a 32-bit Arm core in a compact memory size
- Fast code execution permits increased sleep mode time
- Deterministic, high-performance interrupt handling for time-critical applications
- Single-cycle multiply instruction and hardware divide
- Hardware division and fast digital-signal-processing oriented multiply accumulate
- Saturating arithmetic for signal processing
- IEEE754-compliant single-precision Floating Point Unit (FPU)
- Memory Protection Unit (MPU) for safety-critical applications
- Full debug with data matching for watchpoint generation
  - DWT
  - JTAG debug port
  - FPB
- Trace support reduces the number of pins required for debugging and tracing
  - ITM
  - TPIU with asynchronous serial wire output (SWO)
- Optimized for single-cycle flash memory access
- Tightly connected to 8-KB 4-way random replacement cache for minimal active power consumption and wait states
- Ultra-low-power consumption with integrated sleep modes
- 48-MHz operation
- 1.25 DMIPS per MHz



## 6.4 Radio (RF Core)

The RF Core is a highly flexible and future proof radio module which contains an Arm Cortex-M0 processor that interfaces the analog RF and base-band circuitry, handles data to and from the system CPU side, and assembles the information bits in a given packet structure. The RF core offers a high level, command-based API to the main CPU that configurations and data are passed through. The Arm Cortex-M0 processor is not programmable by customers and is interfaced through the TI-provided RF driver that is included with the SimpleLink Software Development Kit (SDK).

The RF core can autonomously handle the time-critical aspects of the radio protocols, thus offloading the main CPU, which reduces power and leaves more resources for the user application. Several signals are also available to control external circuitry such as RF switches or range extenders autonomously.

The various physical layer radio formats are to an extent built as a firmware defined radio where the radio behavior is either defined by radio ROM contents or by non-ROM radio formats delivered in form of firmware patches with the SimpleLink SDKs. This allows the radio platform to be updated for support of future versions of standards even with over-the-air (OTA) updates while still using the same silicon.

### 6.4.1 Bluetooth 5 low energy

The RF Core offers full support for Bluetooth 5 low energy, including the high-speed 2-Mbps physical layer and the 500-kbps and 125-kbps long range PHYs (Coded PHY) through the TI provided Bluetooth 5 stack or through a high-level Bluetooth API. The Bluetooth 5 PHY and part of the controller are in radio and system ROM, providing significant savings in memory usage and more space available for applications.

The new high-speed mode allows data transfers up to 2 Mbps, twice the speed of Bluetooth 4.2 and five times the speed of Bluetooth 4.0, without increasing power consumption. In addition to faster speeds, this mode offers significant improvements for energy efficiency and wireless coexistence with reduced radio communication time.

Bluetooth 5 also enables unparalleled flexibility for adjustment of speed and range based on application needs, which capitalizes on the high-speed or long-range modes respectively. Data transfers are now possible at 2 Mbps, enabling development of applications using voice, audio, imaging, and data logging that were not previously an option using Bluetooth low energy. With high-speed mode, existing applications deliver faster responses, richer engagement, and longer battery life. Bluetooth 5 enables fast, reliable firmware updates.

## 6.5 Memory

The up to 352KB nonvolatile (Flash) memory provides storage for code and data. The flash memory is in-system programmable and erasable. The last flash memory sector must contain a Customer Configuration section (CCFG) that is used by boot ROM and TI provided drivers to configure the device. This configuration is done through the `cfg.c` source file that is included in all TI provided examples.

The ultra-low leakage system SRAM (static RAM) is split into up to five 16-KB blocks and can be used for both storage of data and execution of code. Retention of SRAM contents in Standby power mode is enabled by default and included in Standby mode power consumption numbers. System SRAM is always initialized to zeroes upon code execution from boot and supports parity checking for detection of bit errors in memory.

To improve code execution speed and lower power when executing code from nonvolatile memory, a 4-way nonassociative 8KB cache is enabled by default to cache and prefetch instructions read by the system CPU. The cache can be used as a general-purpose RAM by enabling this feature in the Customer Configuration Area (CCFG).

There is a 4KB ultra-low leakage SRAM available for use with the Sensor Controller Engine which is typically used for storing Sensor Controller programs, data and configuration parameters. This RAM is also accessible by the system CPU. The Sensor Controller RAM is not cleared to zeroes between system resets.

The ROM includes a TI-RTOS kernel and low-level drivers, as well as significant parts of selected radio stacks, which frees up flash memory for the application. The ROM also contains a serial (SPI and UART) bootloader that can be used for initial programming of the device.

## 6.6 Sensor Controller

The Sensor Controller contains circuitry that can be selectively enabled in both Standby and Active power modes. The peripherals in this domain can be controlled by the Sensor Controller Engine, which is a proprietary power-optimized CPU. This CPU can read and monitor sensors or perform other tasks autonomously; thereby significantly reducing power consumption and offloading the system CPU.

The Sensor Controller Engine is user programmable with a simple programming language that has syntax similar to C. This programmability allows for sensor polling and other tasks to be specified as sequential algorithms rather than static configuration of complex peripheral modules, timers, DMA, register programmable state machines, or event routing.

The main advantages are:

- Flexibility
- Dynamic reuse of hardware resources
- Ability to perform simple data processing without the need for dedicated hardware
- Observability and debugging options

[Sensor Controller Studio](#) is used to write, test, and debug code for the Sensor Controller. The tool produces C driver source code, which the System CPU application uses to control and exchange data with the Sensor Controller. Typical use cases may be (but are not limited to) the following:

- Read analog sensors using integrated ADC or comparators
- Interface digital sensors using GPIOs with SPI or I<sup>2</sup>C (bit-banged)
- Capacitive sensing
- Waveform generation
- Very low-power pulse counting (flow metering)
- Key scan

The peripherals in the Sensor Controller include the following:

- The low-power clocked comparator can be used to wake the system CPU from any state in which the comparator is active. A configurable internal reference DAC can be used in conjunction with the comparator. The output of the comparator can also be used to trigger an interrupt or the ADC.
- Capacitive sensing functionality is implemented through the use of a constant current source, a time-to-digital converter, and a comparator. The continuous time comparator in this block can also be used as a higher-accuracy alternative to the low-power clocked comparator. The Sensor Controller takes care of baseline tracking, hysteresis, filtering, and other related functions when these modules are used for capacitive sensing.
- The ADC is a 12-bit, 200-ksamples/s ADC with eight inputs and a built-in voltage reference. The ADC can be triggered by many different sources including timers, I/O pins, software, and comparators.
- The analog modules can connect to up to eight different GPIOs
- Dedicated SPI master with up to 6-MHz clock speed

The peripherals in the Sensor Controller can also be controlled from the main application processor.

## 6.7 Cryptography

The CC2642R device comes with a wide set of modern cryptography-related hardware accelerators, drastically reducing code footprint and execution time for cryptographic operations. It also has the benefit of being lower power and improves availability and responsiveness of the system because the cryptography operations runs in a background hardware thread.

Together with a large selection of open-source cryptography libraries provided with the Software Development Kit (SDK), this allows for secure and future proof IoT applications to be easily built on top of the platform. The hardware accelerator modules are:

- True Random Number Generator (TRNG) module provides a true, nondeterministic noise source for the purpose of generating keys, initialization vectors (IVs), and other random number requirements. The TRNG is built on 24 ring oscillators that create unpredictable output to feed a complex nonlinear-combinatorial circuit.
- Secure Hash Algorithm 2 (SHA-2) with support for SHA224, SHA256, SHA384, and SHA512
- Advanced Encryption Standard (AES) with 128 and 256 bit key lengths
- Public Key Accelerator - Hardware accelerator supporting mathematical operations needed for elliptic curves up to 512 bits and RSA key pair generation up to 1024 bits.

Through use of these module and the TI provided cryptography drivers, the following capabilities are available for an application or stack:

- Key Agreement Schemes
  - Elliptic curve Diffie–Hellman with static or ephemeral keys (ECDH and ECDHE)
  - Elliptic curve Password Authenticated Key Exchange by Juggling (ECJ-PAKE)
- Signature Generation
  - Elliptic curve Diffie-Hellman Digital Signature Algorithm (ECDSA)
- Curve Support
  - Short Weierstrass form (full hardware support), such as:
    - NIST-P224, NIST-P256, NIST-P384, NIST-P521
    - Brainpool-256R1, Brainpool-384R1, Brainpool-512R1
    - secp256r1
  - Montgomery form (hardware support for multiplication), such as:
    - Curve25519
- SHA2 based MACs
  - HMAC with SHA224, SHA256, SHA384, or SHA512
- Block cipher mode of operation
  - AESCCM
  - AESGCM
  - AESECB
  - AESCBC
  - AESCBC-MAC
- True random number generation

Other capabilities, such as RSA encryption and signatures as well as Edwards type of elliptic curves such as Curve1174 or Ed25519, can also be implemented using the provided hardware accelerators but are not part of the TI SimpleLink SDK for the CC2642R device.

## 6.8 Timers

A large selection of timers are available as part of the CC2642R device. These timers are:

- **Real-Time Clock (RTC)**

- A 70-bit 3-channel timer running on the 32-kHz low frequency system clock (SCLK\_LF)

This timer is available in all power modes except Shutdown. The timer can be calibrated to compensate for frequency drift when using the LF RCOSC as the low frequency system clock. If an external LF clock with frequency different from 32768 Hz is used, the RTC tick speed can be adjusted to compensate for this. When using TI-RTOS, the RTC is used as the base timer in the operating system and should thus only be accessed through the kernel APIs such as the Clock module. The real time clock can also be read by the Sensor Controller Engine to timestamp sensor data and also have dedicated capture channels. By default, the RTC halts when a debugger halts the device.

- **General Purpose Timers (GPTIMER)**

The four flexible GPTIMERS can be used as either 4× 32 bit timers or 8× 16 bit timers, all running on up to 48 MHz. Each of the 16- or 32-bit timers support a wide range of features such as one-shot or periodic counting, pulse width modulation (PWM), time counting between edges and edge counting. The inputs and outputs of the timer are connected to the device event fabric, which allows the timers to interact with signals such as GPIO inputs, other timers, DMA and ADC. The GPTIMERS are available in Active and Idle power modes.

- **Sensor Controller Timers**

The Sensor Controller contains 3 timers:

AUX Timer 0 and 1 are 16-bit timers with a 2<sup>N</sup> prescaler. Timers can either increment on a clock or on each edge of a selected tick source. Both one-shot and periodical timer modes are available

AUX Timer 2 is a 16-bit timer that can operate at 24-MHz, 2-MHz or 32-kHz independent of the Sensor Controller functionality. There are 4 capture or compare channels, which can be operated in one-shot or periodical modes. The timer can be used to generate events for the Sensor Controller or the ADC, as well as for PWM output or waveform generation.

- **Radio Timer**

A multichannel 32-bit-wide timer running on 4 MHz is available as part of the device radio. The radio timer is typically used as the timing base in wireless network communication using the 32-bit timing word as the network time. The radio timer is synchronized with the RTC by using a dedicated radio API when the device radio is turned on or off. This ensures that for a network stack, the radio timer seems to always be running when the radio is enabled. The radio timer is in most cases used indirectly through the trigger time fields in the radio APIs and should only be used when running the accurate 48 MHz high frequency crystal is the source of SCLK\_HF.

- **Watchdog timer**

The watchdog timer is used to regain control if the system operates incorrectly due to software errors. It is typically used to generate an interrupt to and reset of the device for the case where periodic monitoring of the system components and tasks fails to verify proper functionality. The watchdog timer runs on a 1.5-MHz clock rate and cannot be stopped once enabled. The watchdog timer pauses to run in Standby power mode and when a debugger halts the device.

## 6.9 Serial Peripherals and I/O

The SSIs are synchronous serial interfaces that are compatible with SPI, MICROWIRE, and TI's synchronous serial interfaces. The SSIs support both SPI master and slave up to 4 MHz. The SSI modules support configurable phase and polarity.

The UARTs implement universal asynchronous receiver and transmitter functions. They support flexible baud-rate generation up to a maximum of 3 Mbps.

The I<sup>2</sup>S interface is used to handle digital audio and can also be used to interface pulse-density modulation microphones (PDM).

The I<sup>2</sup>C interface is also used to communicate with devices compatible with the I<sup>2</sup>C standard. The I<sup>2</sup>C interface can handle 100-kHz and 400-kHz operation, and can serve as both master and slave.

The I/O controller (IOC) controls the digital I/O pins and contains multiplexer circuitry to allow a set of peripherals to be assigned to I/O pins in a flexible manner. All digital I/Os are interrupt and wake-up capable, have a programmable pullup and pulldown function, and can generate an interrupt on a negative or positive edge (configurable). When configured as an output, pins can function as either push-pull or open-drain. Five GPIOs have high-drive capabilities, which are marked in **bold** in [Section 4](#). All digital peripherals can be connected to any digital pin on the device.

For more information, see the [Technical Reference Manual](#).

## 6.10 Battery and Temperature Monitor

A combined temperature and battery voltage monitor is available in the CC2642R device. The battery and temperature monitor allows an application to continuously monitor on-chip temperature and supply voltage and respond to changes in environmental conditions as needed. The module contains window comparators to interrupt the system CPU when temperature or supply voltage go outside defined windows. These events can also be used to wake up the device from Standby mode through the Always-On (AON) event fabric.

## 6.11 $\mu$ DMA

The device includes a direct memory access ( $\mu$ DMA) controller. The  $\mu$ DMA controller provides a way to offload data-transfer tasks from the system CPU, thus allowing for more efficient use of the processor and the available bus bandwidth. The  $\mu$ DMA controller can perform a transfer between memory and peripherals. The  $\mu$ DMA controller has dedicated channels for each supported on-chip module and can be programmed to automatically perform transfers between peripherals and memory when the peripheral is ready to transfer more data.

Some features of the  $\mu$ DMA controller include the following (this is not an exhaustive list):

- Highly flexible and configurable channel operation of up to 32 channels
- Transfer modes: memory-to-memory, memory-to-peripheral, peripheral-to-memory, and peripheral-to-peripheral
- Data sizes of 8, 16, and 32 bits
- Ping-pong mode for continuous streaming of data

## 6.12 Debug

The on-chip debug support is done through a dedicated cJTAG (IEEE 1149.7) or JTAG (IEEE 1149.1) interface. The device boots by default into cJTAG mode and must be reconfigured to use 4-pin JTAG.

## 6.13 Power Management

To minimize power consumption, the CC2642R supports a number of power modes and power management features (see [Table 6-1](#)).

**Table 6-1. Power Modes,  $V_{DD5} = 3.0V$**

MODE	SOFTWARE CONFIGURABLE POWER MODES				RESET PIN HELD
	ACTIVE	IDLE	STANDBY	SHUTDOWN	
<b>CPU</b>	Active	Off	Off	Off	Off
<b>Flash</b>	On	Available	Off	Off	Off
<b>SRAM</b>	On	On	Retention	Off	Off
<b>Radio</b>	Available	Available	Off	Off	Off
<b>Supply System</b>	On	On	Duty Cycled	Off	Off
Current	3.32 mA	661 $\mu A$	0.9 $\mu A$	0.1 $\mu A$	0.1 $\mu A$
Wake-up time to CPU Active <sup>(1)</sup>	–	14 $\mu s$			
Register and CPU retention	Full	Full	Partial	No	No
SRAM retention	Full	Full	Full	No	No
48 MHz high-speed clock (SCLK_HF)	XOSC_HF or RCOSC_HF	XOSC_HF or RCOSC_HF	Off	Off	Off
2 MHz medium-speed clock (SCLK_MF)	RCOSC_MF	RCOSC_MF	Available	Off	Off
32 kHz low-speed clock (SCLK_LF)	XOSC_LF or RCOSC_LF	XOSC_LF or RCOSC_LF	XOSC_LF or RCOSC_LF	Off	Off
Peripherals	Available	Available	Off	Off	Off
Sensor Controller	Available	Available	Available	Off	Off
Wake-up on RTC	Available	Available	Available	Off	Off
Wake-up on pin edge	Available	Available	Available	Available	Off
Wake-up on reset pin	Available	Available	Available	Available	Available
Brownout detector (BOD)	Active	Active	Duty Cycled	Off	N/A
Power-on reset (POR)	Active	Active	Active	Active	N/A

(1) Not including RTOS overhead

In **Active** mode, the application system CPU is actively executing code. Active mode provides normal operation of the processor and all of the peripherals that are currently enabled. The system clock can be any available clock source (see [Table 6-1](#)).

In **Idle** mode, all active peripherals can be clocked, but the Application CPU core and memory are not clocked and no code is executed. Any interrupt event brings the processor back into active mode.

In **Standby** mode, only the always-on (AON) domain is active. An external wake-up event, RTC event, or Sensor Controller event is required to bring the device back to active mode. MCU peripherals with retention do not need to be reconfigured when waking up again, and the CPU continues execution from where it went into standby mode. All GPIOs are latched in standby mode.

In **Shutdown** mode, the device is entirely turned off (including the AON domain and Sensor Controller), and the I/Os are latched with the value they had before entering shutdown mode. A change of state on any I/O pin defined as a *wake from shutdown pin* wakes up the device and functions as a reset trigger. The CPU can differentiate between reset in this way and reset-by-reset pin or power-on reset by reading the reset status register. The only state retained in this mode is the latched I/O state and the flash memory contents.



The Sensor Controller is an autonomous processor that can control the peripherals in the Sensor Controller independently of the system CPU. This means that the system CPU does not have to wake up, for example to perform an ADC sampling or poll a digital sensor over SPI, thus saving both current and wake-up time that would otherwise be wasted. The [Sensor Controller Studio](#) tool enables the user to program the Sensor Controller, control its peripherals, and wake up the system CPU as needed. All Sensor Controller peripherals can also be controlled by the system CPU.

---

#### NOTE

The power, RF and clock management for the CC2642R device require specific configuration and handling by software for optimized performance. This configuration and handling is implemented in the TI-provided drivers that are part of the CC2642R software development kit (SDK). Therefore, TI highly recommends using this software framework for all application development on the device. The complete [SDK](#) with TI-RTOS (optional), device drivers, and examples are offered free of charge in source code.

---

### 6.14 Clock Systems

The CC2642R device supports two external and two internal clock sources.

A 48-MHz external crystal is required as the frequency reference for the radio. When enabled, it is also used as the system HF clock (SCLK\_HF).

The internal high-speed RC oscillator (48-MHz) can be used as a clock source for the CPU subsystem. (SCLK\_HF)

The 32.768-kHz crystal is optional. The low-speed crystal oscillator is designed for use with a 32.768-kHz watch-type crystal.

The internal low-speed RC oscillator (32-kHz) can be used as a source for SCLK\_LF if the low-power crystal oscillator is not used. The RTC tick speed can be compensated to provide a sleep timer accurate enough for Bluetooth low energy (500 ppm).

The 32-kHz SCLK\_LF can be driven from an external clock through a GPIO. When using a crystal or the internal RC oscillator, the device can output the 32-kHz SCLK\_LF signal to other devices, thereby reducing the overall system cost.

### 6.15 Network Processor

Depending on the product configuration, the CC2642R device can function as a wireless network processor (WNP—a device running the wireless protocol stack with the application running on a separate host MCU), or as a system-on-chip (SoC) with the application and protocol stack running on the system CPU inside the device.

In the first case, the external host MCU communicates with the device using SPI or UART. In the second case, the application must be written according to the application framework supplied with the wireless protocol stack.



## 7 Application, Implementation, and Layout

---

### NOTE

Information in the following Applications section is not part of the TI component specification, and TI does not warrant its accuracy or completeness. TI's customers are responsible for determining suitability of components for their purposes. Customers should validate and test their design implementation to confirm system functionality.

---

### 7.1 LaunchPad™ Development Kit Reference Design

The [LaunchPad Development Kit](#) that supports the CC2642R device also functions as a detailed reference design for schematic and layout.

#### [CC26X2R LaunchPad™ Development Kit Design Files](#)

The CC26X2R LaunchPad Design Files contain detailed schematics and layouts to build application specific boards using the CC2642R device. This design applies to both the CC2642R and CC2652R devices.

## 8 Device and Documentation Support

TI offers an extensive line of development tools. Tools and software to evaluate the performance of the device, generate code, and develop solutions are listed as follows.

### 8.1 Tools and Software

The CC2642R device is supported by a variety of software and hardware development tools.

#### Design Kits and Evaluation Modules

**CC26x2 LaunchPad™ Development Kit** The CC26x2R LaunchPad™ Development Kit enables you to develop high-performance wireless applications that benefit from low-power operation. The kit features the CC2652R SimpleLink Wireless MCU, which allows you to quickly evaluate and prototype 2.4-GHz wireless applications such as Bluetooth 5 low energy, Zigbee and Thread, plus combinations of these. The kit works with the LaunchPad ecosystem, easily enabling additional functionality like sensors, display and more.

The built-in EnergyTrace™ software is an energy-based code analysis tool that measures and displays the application's energy profile and helps to optimize it for ultra-low-power consumption. See [Table 3-1](#) for guidance in selecting the correct device for single-protocol products

#### TI Designs and Reference Designs

**Sub-1 GHz and 2.4 GHz Antenna Kit for LaunchPad™ Development Kit and SensorTag** The antenna kit allows you to do real-life testing to find the optimal antenna for your application. The antenna kit includes 16 antennas for frequencies from 169 MHz to 2.4 GHz, including:

- PCB antennas
- Helical antennas
- Chip antennas
- Dual band antennas for 868 and 915 MHz combined with 2.4 GHz

The antenna kit includes a  $\mu$ SMA(JSC) cable to connect the wireless LaunchPad Development Kits and SensorTags.

#### Software

**SimpleLink™ CC26X2 SDK** The SimpleLink CC26x2 Software Development Kit (SDK) provides a complete package for the development of Bluetooth-based applications for the CC2642R wireless MCU.

The SimpleLink CC26x2 SDK is part of TI's SimpleLink MCU platform, offering a single development environment that delivers flexible hardware, software and tool options for customers developing wired and wireless applications. For more information about the SimpleLink MCU Platform, visit <http://www.ti.com/simplelink>.

#### Development Tools

**Code Composer Studio™ (CCS) Integrated Development Environment (IDE)** Code Composer Studio is an integrated development environment (IDE) that supports TI's Microcontroller and Embedded Processors portfolio. Code Composer Studio comprises a suite of tools used to develop and debug embedded applications. It includes an optimizing C/C++ compiler, source code editor, project build environment, debugger, profiler, and many other features. The intuitive IDE provides a single user interface taking you through each step of the application development flow. Familiar tools and interfaces allow users to get started faster than ever before. Code Composer Studio combines the advantages of the Eclipse® software framework with advanced embedded debug capabilities from TI resulting in a compelling feature-rich development environment for embedded developers.

CCS has support for all SimpleLink Wireless MCUs and includes support for EnergyTrace software (application energy usage profiling). A real-time object viewer plugin is available for TI-RTOS, part of the SimpleLink SDK.

Code Composer Studio is provided free of charge when used in conjunction with the XDS debuggers included on a LaunchPad Development Kit.

**Code Composer Studio (CCS) Cloud IDE** Code Composer Studio (CCS) Cloud is a web-based IDE that allows you to create, edit and build CCS and Energia™ projects. After you have successfully built your project, you can download and run on your connected LaunchPad. Basic debugging, including features like setting breakpoints and viewing variable values is now supported with CCS Cloud.

**IAR Embedded Workbench® for Arm®** IAR Embedded Workbench® is a set of development tools for building and debugging embedded system applications using assembler, C and C++. It provides a completely integrated development environment that includes a project manager, editor, and build tools. IAR has support for all SimpleLink Wireless MCUs. It offers broad debugger support, including XDS110, IAR I-jet™ and Segger J-Link™. A real-time object viewer plugin is available for TI-RTOS, part of the SimpleLink SDK. IAR is also supported out-of-the-box on most software examples provided as part of the SimpleLink SDK.

A 30-day evaluation or a 32 KB size-limited version is available through [iar.com](http://iar.com).

**SmartRF™ Studio** SmartRF Studio is a Windows® application that can be used to evaluate and configure SimpleLink Wireless MCUs from Texas Instruments. The application will help designers of RF systems to easily evaluate the radio at an early stage in the design process. It is especially useful for generation of configuration register values and for practical testing and debugging of the RF system. SmartRF Studio can be used either as a standalone application or together with applicable evaluation boards or debug probes for the RF device.

Features of the SmartRF Studio include:

- Link tests—send and receive packets between nodes
- Antenna and radiation tests—set the radio in continuous wave TX and RX states
- Export radio configuration code for use with the TI SimpleLink SDK RF driver
- Custom GPIO configuration for signaling and control of external switches

**Sensor Controller Studio** Sensor Controller Studio is used to write, test and debug code for the Sensor Controller peripheral. The tool generates a Sensor Controller Interface driver, which is a set of C source files that are compiled into the System CPU application. These source files also contain the Sensor Controller binary image and allow the System CPU application to control and exchange data with the Sensor Controller.

Features of the Sensor Controller Studio include:

- Ready-to-use examples for several common use cases
- Full toolchain with built-in compiler and assembler for programming in a C-like programming language
- Provides rapid development by using the integrated sensor controller task testing and debugging functionality, including visualization of sensor data and verification of algorithms

**CCS UniFlash** CCS UniFlash is a standalone tool used to program on-chip flash memory on TI MCUs. UniFlash has a GUI, command line, and scripting interface. CCS UniFlash is available free of charge.

## 8.2 Documentation Support

To receive notification of documentation updates on data sheets, errata, application notes and similar, navigate to the device product folder on [ti.com/product/CC2642R](http://ti.com/product/CC2642R). In the upper right corner, click on *Alert me* to register and receive a weekly digest of any product information that has changed. For change details, review the revision history included in any revised document.

The current documentation that describes the DSP, related peripherals, and other technical collateral is listed as follows.

### TI Resource Explorer

**TI Resource Explorer** Software examples, libraries, executables, and documentation are available for your device and development board.

### Errata

**CC2642R Silicon Errata** The silicon errata describes the known exceptions to the functional specifications for each silicon revision of the device.

### Technical Reference Manual (TRM)

**CC13x2x, CC26x2x SimpleLink™ Wireless MCU TRM** The TRM provides a detailed description of all modules and peripherals available in the device family.

### 8.2.1 TI Wireless Connectivity Website

TI's Wireless Connectivity website has all the latest products, application and design notes, news and updates. Go to [www.ti.com/wireless](http://www.ti.com/wireless).

### 8.2.2 TI Design Network

The TI Design Network is a worldwide community of respected, well-established companies offering products and services that complement TI's semiconductor device solutions. Products and services include a broad range of reference designs, turnkey products and services, system modules, embedded software, engineering services, and development tools that help customers accelerate development efforts and reduce time-to-market.

Search the network on [www.ti.com/3p](http://www.ti.com/3p) to find a suitable partner for modules, engineering services, or development tools.

## 8.3 Community Resources

The following links connect to TI community resources. Linked contents are provided "AS IS" by the respective contributors. They do not constitute TI specifications and do not necessarily reflect TI's views; see TI's [Terms of Use](#).

**TI E2E™ Online Community** The TI engineer-to-engineer (E2E) community was created to foster collaboration among engineers. At [e2e.ti.com](http://e2e.ti.com), you can ask questions, share knowledge, explore ideas and help solve problems with fellow engineers.

**TI Embedded Processors Wiki** Established to help developers get started with Embedded Processors from Texas Instruments and to foster innovation and growth of general knowledge about the hardware and software surrounding these devices.

## 8.4 Trademarks

SmartRF, EnergyTrace, Code Composer Studio, E2E are trademarks of Texas Instruments.  
 LaunchPad is a trademark of Texas Instruments Inc.  
 Arm, Cortex, Arm Thumb are registered trademarks of Arm Limited (or its subsidiaries).  
 Bluetooth is a registered trademark of Bluetooth SIG Inc.  
 Eclipse is a registered trademark of Eclipse Foundation.  
 CoreMark is a registered trademark of Embedded Microprocessor Benchmark Consortium.  
 I-jet is a trademark of IAR Systems AB.  
 IAR Embedded Workbench is a registered trademark of IAR Systems AB.  
 IEEE Std 1241 is a trademark of Institute of Electrical and Electronics Engineers, Incorporated.  
 Windows is a registered trademark of Microsoft Corporation.  
 Wi-Fi is a registered trademark of Wi-Fi Alliance.  
 J-Link is a trademark of other.  
 All other trademarks are the property of their respective owners.

## 8.5 Electrostatic Discharge Caution



This integrated circuit can be damaged by ESD. Texas Instruments recommends that all integrated circuits be handled with appropriate precautions. Failure to observe proper handling and installation procedures can cause damage.

ESD damage can range from subtle performance degradation to complete device failure. Precision integrated circuits may be more susceptible to damage because very small parametric changes could cause the device not to meet its published specifications.

## 8.6 Glossary

[TI Glossary](#) This glossary lists and explains terms, acronyms, and definitions.

# 9 Mechanical, Packaging, and Orderable Information

## 9.1 Packaging Information

The following pages include mechanical packaging and orderable information. This information is the most current data available for the designated devices. This data is subject to change without notice and revision of this document. For browser-based versions of this data sheet, refer to the left-hand navigation.

**PACKAGING INFORMATION**

Orderable Device	Status (1)	Package Type	Package Drawing	Pins	Package Qty	Eco Plan (2)	Lead/Ball Finish (6)	MSL Peak Temp (3)	Op Temp (°C)	Device Marking (4/5)	Samples
CC2642R1FRGZR	PREVIEW	VQFN	RGZ	48	2500	TBD	Call TI	Call TI	-40 to 85		
CC2642R1FRGZT	PREVIEW	VQFN	RGZ	48	250	TBD	Call TI	Call TI	-40 to 85		
XCC2642R1FRGZR	ACTIVE	VQFN	RGZ	48	2500	Green (RoHS & no Sb/Br)	CU NIPDAU   CU NIPDAUAG	Level-3-260C-168 HR	-40 to 85	(CC2642, XCC2642) R1F	Samples

(1) The marketing status values are defined as follows:

**ACTIVE:** Product device recommended for new designs.

**LIFEBUY:** TI has announced that the device will be discontinued, and a lifetime-buy period is in effect.

**NRND:** Not recommended for new designs. Device is in production to support existing customers, but TI does not recommend using this part in a new design.

**PREVIEW:** Device has been announced but is not in production. Samples may or may not be available.

**OBSOLETE:** TI has discontinued the production of the device.

(2) **RoHS:** TI defines "RoHS" to mean semiconductor products that are compliant with the current EU RoHS requirements for all 10 RoHS substances, including the requirement that RoHS substance do not exceed 0.1% by weight in homogeneous materials. Where designed to be soldered at high temperatures, "RoHS" products are suitable for use in specified lead-free processes. TI may reference these types of products as "Pb-Free".

**RoHS Exempt:** TI defines "RoHS Exempt" to mean products that contain lead but are compliant with EU RoHS pursuant to a specific EU RoHS exemption.

**Green:** TI defines "Green" to mean the content of Chlorine (Cl) and Bromine (Br) based flame retardants meet JS709B low halogen requirements of <=1000ppm threshold. Antimony trioxide based flame retardants must also meet the <=1000ppm threshold requirement.

(3) MSL, Peak Temp. - The Moisture Sensitivity Level rating according to the JEDEC industry standard classifications, and peak solder temperature.

(4) There may be additional marking, which relates to the logo, the lot trace code information, or the environmental category on the device.

(5) Multiple Device Markings will be inside parentheses. Only one Device Marking contained in parentheses and separated by a "~" will appear on a device. If a line is indented then it is a continuation of the previous line and the two combined represent the entire Device Marking for that device.

(6) Lead/Ball Finish - Orderable Devices may have multiple material finish options. Finish options are separated by a vertical ruled line. Lead/Ball Finish values may wrap to two lines if the finish value exceeds the maximum column width.

**Important Information and Disclaimer:**The information provided on this page represents TI's knowledge and belief as of the date that it is provided. TI bases its knowledge and belief on information provided by third parties, and makes no representation or warranty as to the accuracy of such information. Efforts are underway to better integrate information from third parties. TI has taken and continues to take reasonable steps to provide representative and accurate information but may not have conducted destructive testing or chemical analysis on incoming materials and chemicals. TI and TI suppliers consider certain information to be proprietary, and thus CAS numbers and other limited information may not be available for release.

In no event shall TI's liability arising out of such information exceed the total purchase price of the TI part(s) at issue in this document sold by TI to Customer on an annual basis.



## TAPE AND REEL INFORMATION



### QUADRANT ASSIGNMENTS FOR PIN 1 ORIENTATION IN TAPE



\*All dimensions are nominal

Device	Package Type	Package Drawing	Pins	SPQ	Reel Diameter (mm)	Reel Width W1 (mm)	A0 (mm)	B0 (mm)	K0 (mm)	P1 (mm)	W (mm)	Pin1 Quadrant
XCC2642R1FRGZR	VQFN	RGZ	48	2500	330.0	16.4	7.3	7.3	1.1	12.0	16.0	Q2



TAPE AND REEL BOX DIMENSIONS



\*All dimensions are nominal

Device	Package Type	Package Drawing	Pins	SPQ	Length (mm)	Width (mm)	Height (mm)
XCC2642R1FRGZR	VQFN	RGZ	48	2500	336.6	336.6	31.8

RGZ (S-PVQFN-N48)

PLASTIC QUAD FLATPACK NO-LEAD



- NOTES:
- A. All linear dimensions are in millimeters. Dimensioning and tolerancing per ASME Y14.5M-1994.
  - B. This drawing is subject to change without notice.
  - C. Quad Flatpack, No-leads (QFN) package configuration.
  - D. The package thermal pad must be soldered to the board for thermal and mechanical performance.
  - E. See the additional figure in the Product Data Sheet for details regarding the exposed thermal pad features and dimensions.
  - F. Falls within JEDEC MO-220.

**THERMAL INFORMATION**

This package incorporates an exposed thermal pad that is designed to be attached directly to an external heatsink. The thermal pad must be soldered directly to the printed circuit board (PCB). After soldering, the PCB can be used as a heatsink. In addition, through the use of thermal vias, the thermal pad can be attached directly to the appropriate copper plane shown in the electrical schematic for the device, or alternatively, can be attached to a special heatsink structure designed into the PCB. This design optimizes the heat transfer from the integrated circuit (IC).

For information on the Quad Flatpack No-Lead (QFN) package and its advantages, refer to Application Report, QFN/SON PCB Attachment, Texas Instruments Literature No. SLUA271. This document is available at [www.ti.com](http://www.ti.com).

The exposed thermal pad dimensions for this package are shown in the following illustration.

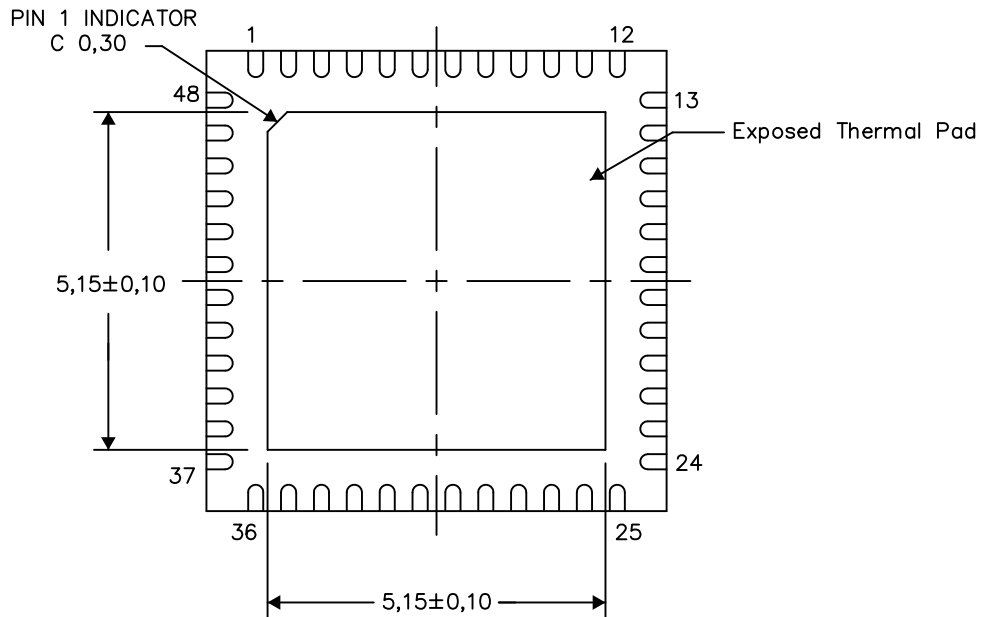

Bottom View

Exposed Thermal Pad Dimensions

4206354-2/Z 03/15

NOTE: All linear dimensions are in millimeters

RGZ (S-PVQFN-N48)

PLASTIC QUAD FLATPACK NO-LEAD

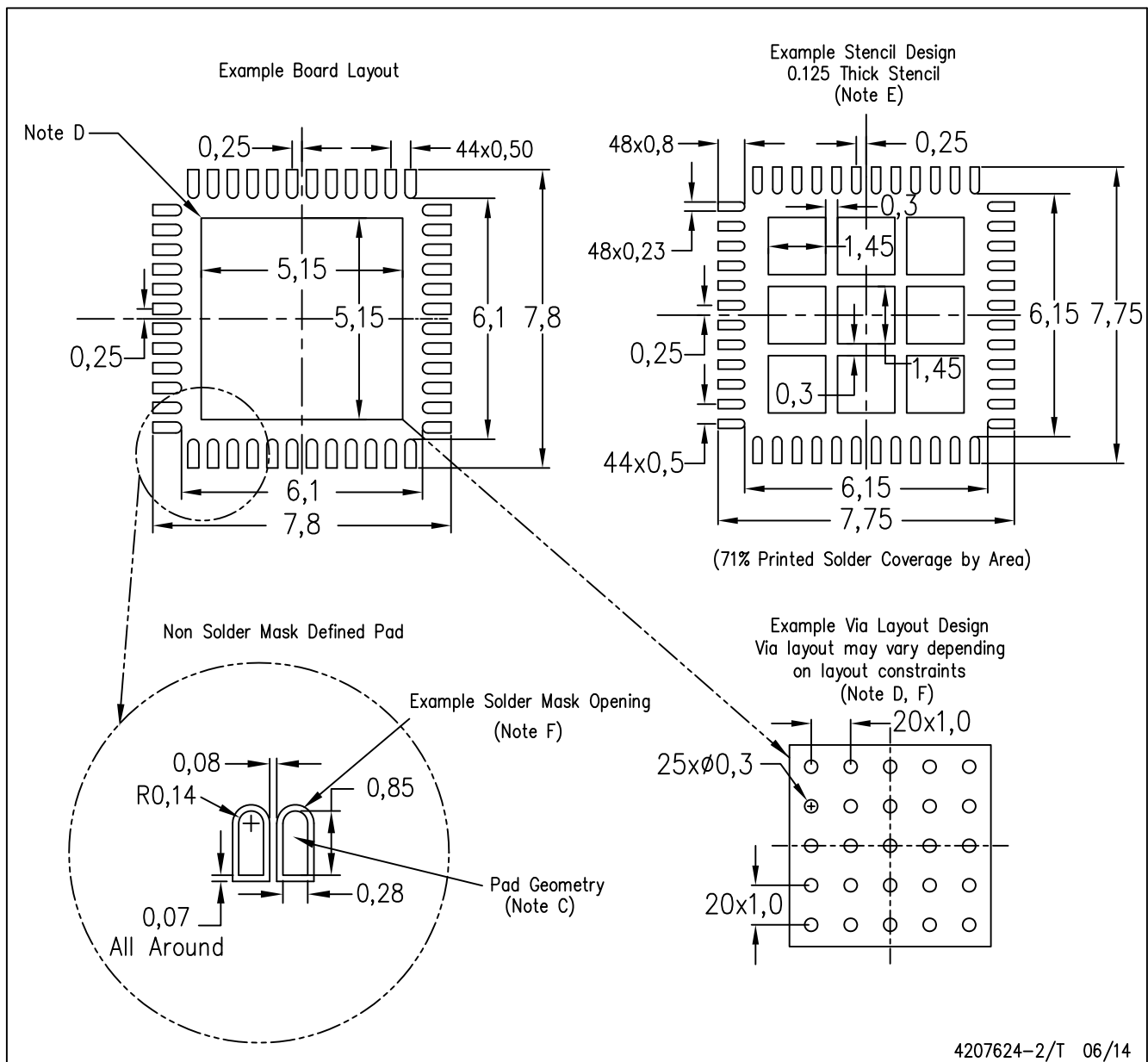

- NOTES:
- All linear dimensions are in millimeters.
  - This drawing is subject to change without notice.
  - Publication IPC-7351 is recommended for alternate designs.
  - This package is designed to be soldered to a thermal pad on the board. Refer to Application Note, Quad Flat-Pack Packages, Texas Instruments Literature No. SLUA271, and also the Product Data Sheets for specific thermal information, via requirements, and recommended board layout. These documents are available at [www.ti.com](http://www.ti.com) <<http://www.ti.com>>.
  - Laser cutting apertures with trapezoidal walls and also rounding corners will offer better paste release. Customers should contact their board assembly site for stencil design recommendations. Refer to IPC 7525 for stencil design considerations.
  - Customers should contact their board fabrication site for recommended solder mask tolerances and via tenting recommendations for vias placed in the thermal pad.

## IMPORTANT NOTICE

Texas Instruments Incorporated (TI) reserves the right to make corrections, enhancements, improvements and other changes to its semiconductor products and services per JESD46, latest issue, and to discontinue any product or service per JESD48, latest issue. Buyers should obtain the latest relevant information before placing orders and should verify that such information is current and complete.

TI's published terms of sale for semiconductor products (<http://www.ti.com/sc/docs/stdterms.htm>) apply to the sale of packaged integrated circuit products that TI has qualified and released to market. Additional terms may apply to the use or sale of other types of TI products and services.

Reproduction of significant portions of TI information in TI data sheets is permissible only if reproduction is without alteration and is accompanied by all associated warranties, conditions, limitations, and notices. TI is not responsible or liable for such reproduced documentation. Information of third parties may be subject to additional restrictions. Resale of TI products or services with statements different from or beyond the parameters stated by TI for that product or service voids all express and any implied warranties for the associated TI product or service and is an unfair and deceptive business practice. TI is not responsible or liable for any such statements.

Buyers and others who are developing systems that incorporate TI products (collectively, "Designers") understand and agree that Designers remain responsible for using their independent analysis, evaluation and judgment in designing their applications and that Designers have full and exclusive responsibility to assure the safety of Designers' applications and compliance of their applications (and of all TI products used in or for Designers' applications) with all applicable regulations, laws and other applicable requirements. Designer represents that, with respect to their applications, Designer has all the necessary expertise to create and implement safeguards that (1) anticipate dangerous consequences of failures, (2) monitor failures and their consequences, and (3) lessen the likelihood of failures that might cause harm and take appropriate actions. Designer agrees that prior to using or distributing any applications that include TI products, Designer will thoroughly test such applications and the functionality of such TI products as used in such applications.

TI's provision of technical, application or other design advice, quality characterization, reliability data or other services or information, including, but not limited to, reference designs and materials relating to evaluation modules, (collectively, "TI Resources") are intended to assist designers who are developing applications that incorporate TI products; by downloading, accessing or using TI Resources in any way, Designer (individually or, if Designer is acting on behalf of a company, Designer's company) agrees to use any particular TI Resource solely for this purpose and subject to the terms of this Notice.

TI's provision of TI Resources does not expand or otherwise alter TI's applicable published warranties or warranty disclaimers for TI products, and no additional obligations or liabilities arise from TI providing such TI Resources. TI reserves the right to make corrections, enhancements, improvements and other changes to its TI Resources. TI has not conducted any testing other than that specifically described in the published documentation for a particular TI Resource.

Designer is authorized to use, copy and modify any individual TI Resource only in connection with the development of applications that include the TI product(s) identified in such TI Resource. NO OTHER LICENSE, EXPRESS OR IMPLIED, BY ESTOPPEL OR OTHERWISE TO ANY OTHER TI INTELLECTUAL PROPERTY RIGHT, AND NO LICENSE TO ANY TECHNOLOGY OR INTELLECTUAL PROPERTY RIGHT OF TI OR ANY THIRD PARTY IS GRANTED HEREIN, including but not limited to any patent right, copyright, mask work right, or other intellectual property right relating to any combination, machine, or process in which TI products or services are used. Information regarding or referencing third-party products or services does not constitute a license to use such products or services, or a warranty or endorsement thereof. Use of TI Resources may require a license from a third party under the patents or other intellectual property of the third party, or a license from TI under the patents or other intellectual property of TI.

TI RESOURCES ARE PROVIDED "AS IS" AND WITH ALL FAULTS. TI DISCLAIMS ALL OTHER WARRANTIES OR REPRESENTATIONS, EXPRESS OR IMPLIED, REGARDING RESOURCES OR USE THEREOF, INCLUDING BUT NOT LIMITED TO ACCURACY OR COMPLETENESS, TITLE, ANY EPIDEMIC FAILURE WARRANTY AND ANY IMPLIED WARRANTIES OF MERCHANTABILITY, FITNESS FOR A PARTICULAR PURPOSE, AND NON-INFRINGEMENT OF ANY THIRD PARTY INTELLECTUAL PROPERTY RIGHTS. TI SHALL NOT BE LIABLE FOR AND SHALL NOT DEFEND OR INDEMNIFY DESIGNER AGAINST ANY CLAIM, INCLUDING BUT NOT LIMITED TO ANY INFRINGEMENT CLAIM THAT RELATES TO OR IS BASED ON ANY COMBINATION OF PRODUCTS EVEN IF DESCRIBED IN TI RESOURCES OR OTHERWISE. IN NO EVENT SHALL TI BE LIABLE FOR ANY ACTUAL, DIRECT, SPECIAL, COLLATERAL, INDIRECT, PUNITIVE, INCIDENTAL, CONSEQUENTIAL OR EXEMPLARY DAMAGES IN CONNECTION WITH OR ARISING OUT OF TI RESOURCES OR USE THEREOF, AND REGARDLESS OF WHETHER TI HAS BEEN ADVISED OF THE POSSIBILITY OF SUCH DAMAGES.

Unless TI has explicitly designated an individual product as meeting the requirements of a particular industry standard (e.g., ISO/TS 16949 and ISO 26262), TI is not responsible for any failure to meet such industry standard requirements.

Where TI specifically promotes products as facilitating functional safety or as compliant with industry functional safety standards, such products are intended to help enable customers to design and create their own applications that meet applicable functional safety standards and requirements. Using products in an application does not by itself establish any safety features in the application. Designers must ensure compliance with safety-related requirements and standards applicable to their applications. Designer may not use any TI products in life-critical medical equipment unless authorized officers of the parties have executed a special contract specifically governing such use. Life-critical medical equipment is medical equipment where failure of such equipment would cause serious bodily injury or death (e.g., life support, pacemakers, defibrillators, heart pumps, neurostimulators, and implantables). Such equipment includes, without limitation, all medical devices identified by the U.S. Food and Drug Administration as Class III devices and equivalent classifications outside the U.S.

TI may expressly designate certain products as completing a particular qualification (e.g., Q100, Military Grade, or Enhanced Product). Designers agree that it has the necessary expertise to select the product with the appropriate qualification designation for their applications and that proper product selection is at Designers' own risk. Designers are solely responsible for compliance with all legal and regulatory requirements in connection with such selection.

Designer will fully indemnify TI and its representatives against any damages, costs, losses, and/or liabilities arising out of Designer's non-compliance with the terms and provisions of this Notice.