

Analog Peripherals

10-Bit ADC (C8051T620/320/321 only)

- Up to 500 ksps
- Up to 21 external inputs
- VREF from on-chip VREF, external pin, Internal 1.8 V Regulator or V_{DD}
- Internal or external start of conversion source
- Built-in temperature sensor

Comparators

- Programmable hysteresis and response time
- Configurable as interrupt or reset source
- Low current (<0.5 μA)

USB Function Controller

- USB specification 2.0 compliant
- Full speed (12 Mbps) or low speed (1.5 Mbps) operation
- Integrated clock recovery; no external oscillator required for full speed or low speed
- Supports six flexible endpoints
- 1 kB USB buffer memory
- Integrated transceiver; no external resistors required

On-Chip Debug

- C8051F34A can be used as code development platform; Complete development kit available
- On-chip debug circuitry facilitates full speed, nonintrusive in-system debug
- Provides breakpoints, single stepping, inspect/modify memory and registers

Supply Voltage: 1.8 to 5.25 V

- On-chip LDO for internal core supply
- Built-in supply voltage monitor

Temperature Range: -40 to +85 °C

High-Speed 8051 μC Core

- Pipelined instruction architecture; executes 70% of instructions in 1 or 2 system clocks
- Up to 48 MIPS throughput with 48 MHz clock
- Expanded interrupt handler

Memory

- 1280 bytes internal data RAM (256 + 1024)
- 16 kB byte-programmable EPROM code memory
- EPROM can be programmed from firmware running on the device

Digital Peripherals

- 25 Port I/O with high sink current capability
- Hardware enhanced SPI™, SMBus™, and two enhanced UART serial ports
- Four general purpose 16-bit counter/timers
- 16-bit programmable counter array (PCA) with five capture/compare modules and enhanced PWM functionality

Clock Sources

- Two internal oscillators:
 - 48 MHz: ±0.25% accuracy with clock recovery enabled. Supports all USB and UART modes
 - 80/40/20/10 kHz low frequency, low power
- External oscillator: Crystal, RC, C, or CMOS Clock
- Can switch between clock sources on-the-fly; useful in power saving modes

Package Options

- 5x5 mm QFN28 or QFN32
- LQFP32

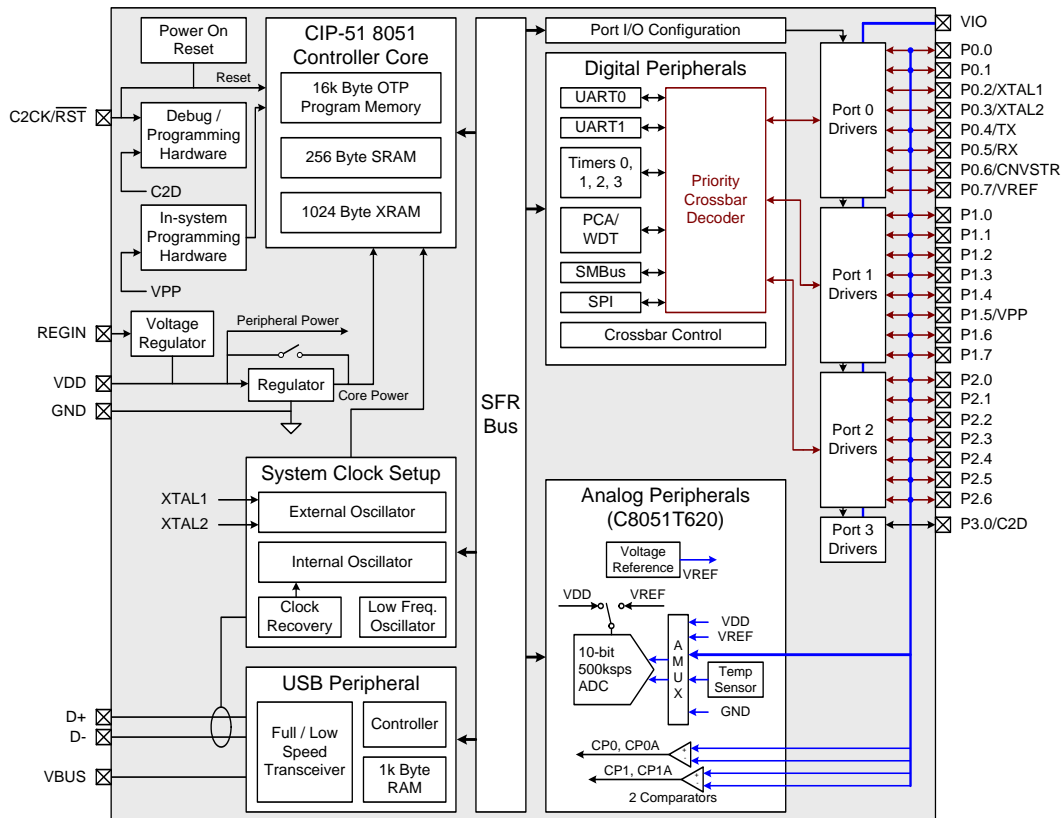

Product Selection Guide

Ordering Part Number	MIPS (Peak)	EPROM Code Memory (Bytes)	RAM (Bytes)	Calibrated Internal 48 MHz Oscillator	Internal 80 kHz Oscillator	USB with 256 Bytes Endpoint RAM	Supply Voltage Regulator	SMBus/I ² C	Enhanced SPI	UARTs	Timers (16-bit)	Programmable Counter Array	Digital Port I/Os	10-Bit 500 ksp/s ADC	Internal Voltage Reference	Temperature Sensor	Analog Comparator	Lead-Free (RoHS Compliant)	Package
C8051T620-GM	48	16k ¹	1280	Y	Y	Y	Y	Y	Y	2	4	Y	24	Y	Y	Y	2	Y	QFN32
C8051T621-GM	48	16k ¹	1280	Y	Y	Y	Y	Y	Y	2	4	Y	24	—	—	—	2	Y	QFN32
C8051T320-GQ ²	48	16k ¹	1280	Y	Y	Y	Y	Y	Y	2	4	Y	25	Y	Y	Y	2	Y	LQFP32
C8051T321-GM ³	48	16k ¹	1280	Y	Y	Y	Y	Y	Y	2	4	Y	21	Y	Y	Y	2	Y	QFN28
C8051T322-GQ ²	48	16k ¹	1280	Y	Y	Y	Y	Y	Y	2	4	Y	25	—	—	—	2	Y	LQFP32
C8051T323-GM ³	48	16k ¹	1280	Y	Y	Y	Y	Y	Y	2	4	Y	21	—	—	—	2	Y	QFN28

Notes:

1. 512 bytes reserved for factory use.
2. Pin compatible with the C8051F320-GM.
3. Pin compatible with the C8051F321-GM.

Selected Electrical Characteristics

Parameter	Conditions	Min	Typ	Max	Units
Supply Voltage	Regulator1 in Normal Mode	1.8	3.0	3.6	V
	Regulator1 in Bypass Mode	1.75	—	1.9	V
SYSCLK (System Clock)		0	—	48	MHz
Specified Operating Temp Range		-40	—	+85	°C
Voltage Regulator (REG0)					
Input Voltage Range		2.7	—	5.25	V
Output Voltage (V _{DD})	Output Current=1 to 100 mA	3.3	3.45	3.6	V
Output Current		—	—	100	mA
ADC-DC Accuracy					
Resolution			10		bits
SAR Conversion Clock		—	—	8	MHz
Throughput Rate		—	—	500	ksp/s
Voltage Reference					
Output Voltage	1.2 V setting, 25 °C ambient	—	1.2	1.3	V
	2.4 V setting, 25 °C ambient	1.1	2.4	2.5	
VREF Short-Circuit Current		—	4.5	6	mA
Comparators					
Response Time: Mode 0, V _{cm} = 1.5 V	CP0+ – CP0– = 100 mV	—	240	—	ns
	CP0+ – CP0– = -100 mV	—	240	—	ns

C8051T62x Development Kit

