

Ultra-Low Power

- 150 μ A/MHz active current from 1.8–3.6 V @ 25 MHz
- 10 nA sleep current with data retention; BOD disabled
- 50 nA sleep current with data retention; BOD enabled
- 300 nA sleep current with smaRTClock (internal oscillator)
- 600 nA sleep current with smaRTClock (external crystal)
- 2 μ s wake up from sleep
- 1.5 μ s analog settling time

Supply Voltage 1.8 to 3.6 V

- Built-in brown-out detector
- On-chip LDO regulator for core supply

Analog to Digital Converter

- 75 ksp/s with 12-bit resolution
- 300 ksp/s with 10-bit resolution
- 330 ksp/s with 8-bit resolution
- Up to 10-channels
- Autonomous burst mode with 16-bit averaging accumulator
- VREF from external pin, VDD, or internal regulator
- Built-in temperature sensor

Internal 6-Bit Current Reference

- 2 ranges: source or sink capability
- Enhanced resolution via PWM interpolation

Comparator

- Programmable hysteresis and response time
- Configurable as interrupt or reset source
- Low current (< 0.4 μ A)

Development Kit: C8051F996DK

High-Speed 8051 μ C Core

- Pipe-lined instruction architecture; executes 70% of instructions in 1 or 2 system clocks
- 25 MIPS peak throughput with 25 MHz clock
- Expanded interrupt handler

Memory

- 512 bytes internal data RAM (256 + 256)
- Up to 8 kB Flash; In-system programmable in 512 byte sectors; Full read/write/erase functionality over the entire supply range

On-Chip Debug

- On-chip debug circuitry facilitates full speed, non-intrusive in-system debug

Digital Peripherals

- Up to 17 port I/O; Programmable drive strength
- Hardware enhanced UART, SPI and SMBus™ serial ports
- CRC block provides 16-Bit CCITT polynomial calculation
- Four general purpose 16-bit counter/timers
- 16-bit programmable counter array (PCA) with three capture/compare modules and enhanced PWM functionality

Clock Sources

- 24.5 MHz \pm 2% oscillator; supports crystal-less UART operation
- Low power internal oscillator: 20 MHz
- External oscillator: Crystal, RC, C, CMOS clock
- Can switch clock sources on-the-fly; useful for power saving modes

Temperature Range: -40 to +85 °C

Package Options

- 24-pin QFN (4x4 mm), RoHS compliant
- 24-pin QSOP (easy to hand solder) RoHS compliant
- 20-pin QFN (3x3 mm), RoHS compliant

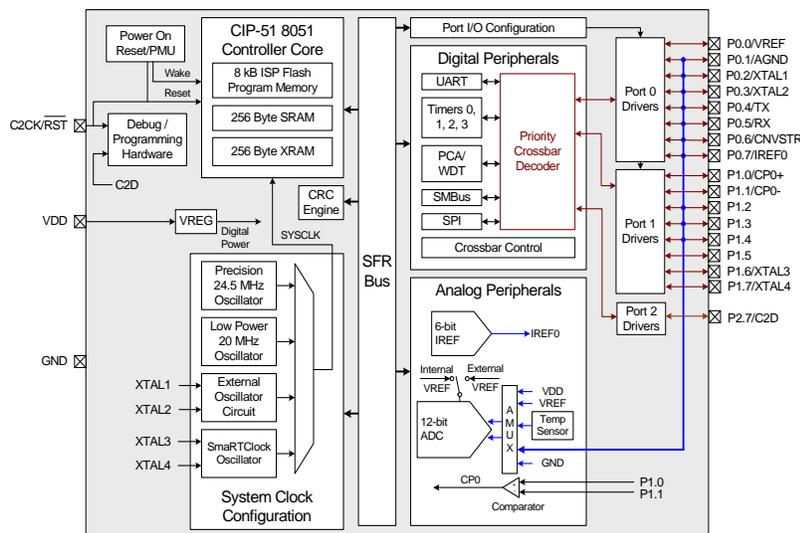

Selected Electrical Specifications

(At 25 C°)

Parameter	Conditions	Min	Typ	Max	Units
Supply Input Voltage		1.8	—	3.6	V
Supply Current with CPU Active	Clock = 24.5 MHz (±2% internal precision oscillator)	—	150	—	µA/MHz
Supply Current (shutdown) (V _{BAT} = 1.8 V)	Sleep mode; BOD off	—	.010	—	µA
	Sleep mode; BOD on	—	.050	—	µA
	Sleep mode; smartClock running	—	.300	—	µA
Clock Frequency Range		DC	—	25	MHz
Wakeup Time		—	2	—	µs
Analog Settling Time		—	1.5	—	µs
Internal Oscillator					
Frequency	Precision oscillator	24	24.5	25	MHz
	Low power oscillator	18	20	22	MHz
A/D Converter					
Resolution				12/10	bits
Throughput Rate		—	—	75/300	ksps

C8051F9xx Ultra Low Power Product Family

Part #	Flash Mem.	RAM (Bytes)	MIPS (Peak)	Digital I/O	Communications	ADC	Sensing Channels	Operating Voltage	Package	Dev kit
C8051F930	64 kB	4352	25	24	EMIF, I ² C, 2xSPI, UART	10-bit	—	0.9–3.6 V	QFN32/LQFP32	C8051F930DK
C8051F931	64 kB	4352	25	16	I ² C, 2xSPI, UART	10-bit	—	0.9–3.6 V	QFN24	C8051F930DK
C8051F920	32 kB	4352	25	24	EMIF, I ² C, 2xSPI, UART	10-bit	—	0.9–3.6 V	QFN32/LQFP32	C8051F930DK
C8051F921	32 kB	4352	25	16	I ² C, 2xSPI, UART	10-bit	—	0.9–3.6 V	QFN24	C8051F930DK
C8051F911	16 kB	768	25	16	I ² C, 2xSPI, UART	10-bit	—	0.9–3.6 V	QFN24/QSOP24	C8051F912DK
C8051F912	16 kB	768	25	16	I ² C, 2xSPI, UART	12-bit	—	0.9–3.6 V	QFN24/QSOP24	C8051F912DK
C8051F901	8 kB	768	25	16	I ² C, 2xSPI, UART	10-bit	—	0.9–3.6 V	QFN24/QSOP24	C8051F912DK
C8051F902	8 kB	768	25	16	I ² C, 2xSPI, UART	12-bit	—	0.9–3.6 V	QFN24/QSOP24	C8051F912DK
C8051F980	8 kB	512	25	16	I²C, SPI, UART	12-bit	—	1.8–3.6 V	QFN20	C8051F996DK
C8051F981	8 kB	512	25	16	I²C, SPI, UART	—	—	1.8–3.6 V	QFN20	C8051F996DK
C8051F982	4 kB	512	25	16	I²C, SPI, UART	10-bit	—	1.8–3.6 V	QFN20	C8051F996DK
C8051F983	4 kB	512	25	16	I²C, SPI, UART	—	—	1.8–3.6 V	QFN20	C8051F996DK
C8051F985	2 kB	512	25	16	I²C, SPI, UART	—	—	1.8–3.6 V	QFN20	C8051F996DK
C8051F986	8 kB	512	25	17	I²C, SPI, UART	12-bit	—	1.8–3.6 V	QFN24/QSOP24	C8051F996DK
C8051F987	8 kB	512	25	17	I²C, SPI, UART	—	—	1.8–3.6 V	QFN24/QSOP24	C8051F996DK
C8051F988	4 kB	512	25	17	I²C, SPI, UART	10-bit	—	1.8–3.6 V	QFN24/QSOP24	C8051F996DK
C8051F989	4 kB	512	25	17	I²C, SPI, UART	—	—	1.8–3.6 V	QFN24/QSOP24	C8051F996DK
C8051F990	8 kB	512	25	16	I ² C, SPI, UART	12-bit	13	1.8–3.6 V	QFN20	C8051F996DK
C8051F991	8 kB	512	25	16	I ² C, SPI, UART	—	13	1.8–3.6 V	QFN20	C8051F996DK
C8051F996	8 kB	512	25	17	I ² C, SPI, UART	12-bit	14	1.8–3.6 V	QFN24/QSOP24	C8051F996DK
C8051F997	8 kB	512	25	17	I ² C, SPI, UART	—	14	1.8–3.6 V	QFN24/QSOP24	C8051F996DK