

PROFET™ + 24V

BTT6200-4ESA

Feature list

- Quad channel device
- Very low stand-by current
- 3.3 V and 5 V compatible logic inputs
- Electrostatic discharge protection (ESD)
- Optimized electromagnetic compatibility
- Logic ground independent from load ground
- Very low power DMOS leakage current in OFF state
- Green product (RoHS compliant)

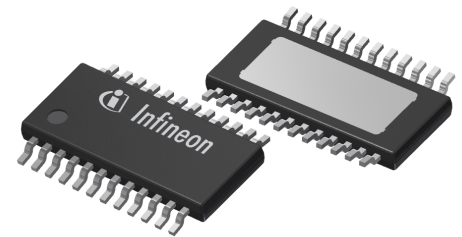

Potential applications

- Suitable for resistive, inductive and capacitive loads
- Replaces electromechanical relays, fuses and discrete circuits
- Most suitable for loads with high inrush current, such as lamps
- Suitable for 12 V and 24 V trucks and transportation systems

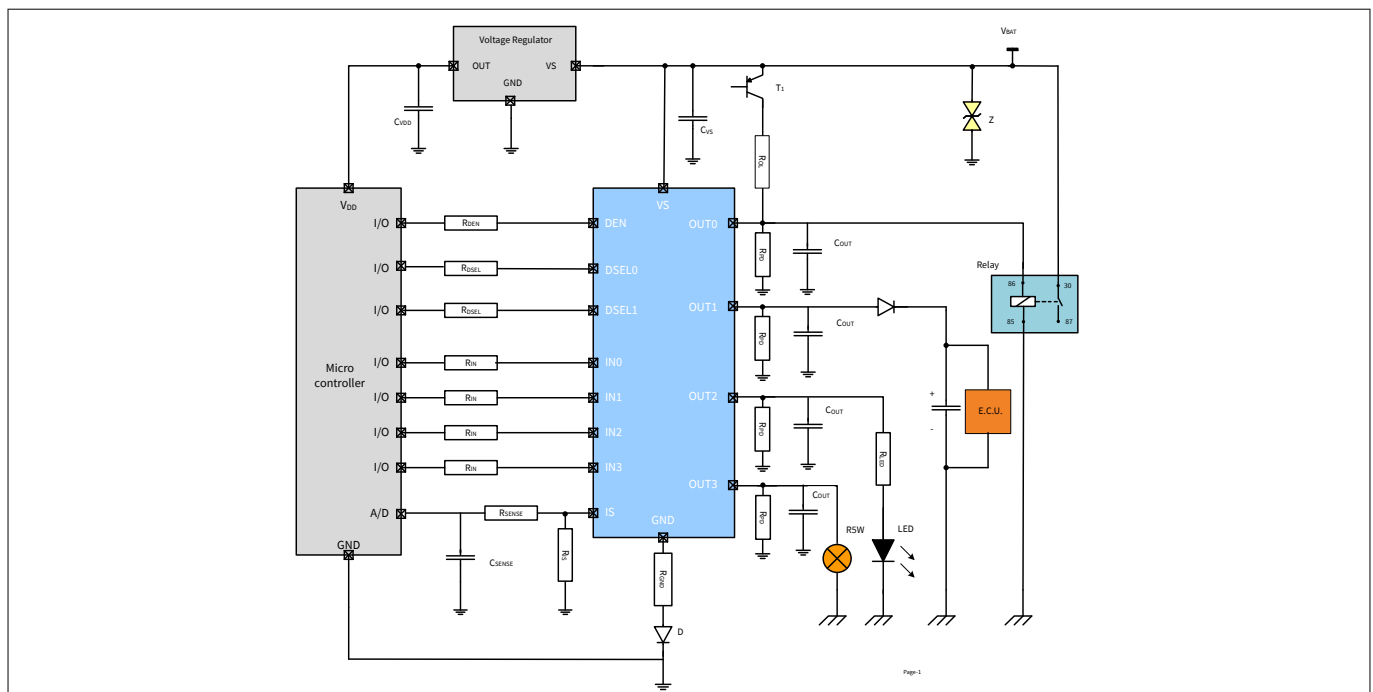

Figure 1 Application Diagram with BTT6200-4ESA

Product Type	Package	Marking
BTT6200-4ESA	PG-TSDSO-24	BTT62004ESA

Product summary

Product summary

The BTT6200-4ESA is a 200 mΩ quad channel Smart High-Side Power Switch, embedded in a PG-TSDSO-24 package, providing protective functions and diagnosis.

The power transistor is built by an N-channel vertical power MOSFET with charge pump. The device is integrated in Smart6 HV technology. It is specially designed to drive lamps up to R10 W 24 V or R5 W 12 V, as well as LEDs in the harsh automotive environment.

Table 1 **Product summary**

Parameter	Symbol	Value
Operating voltage range	$V_{S(OP)}$	5 V to 36 V
Maximum supply voltage	$V_{S(LD)}$	65 V
Maximum ON state resistance at $T_J = 150^\circ\text{C}$ per channel	$R_{DS(ON)}$	400 mΩ
Nominal load current (one channel active)	$I_{L(NOM)1}$	1.5 A
Nominal load current (all channels active)	$I_{L(NOM)2}$	1 A
Typical current sense ratio	k_{ILIS}	300
Minimum current limitation	$I_{L5(SC)}$	9 A
Maximum standby current with load at $T_J = 25^\circ\text{C}$	$I_{S(OFF)}$	500 nA

Diagnostic functions

- Proportional load current sense multiplexed for the 4 channels
- Open load detection in ON and OFF
- Short circuit to battery and ground indication
- Overtemperature switch off detection
- Stable diagnostic signal during short circuit
- Enhanced k_{ILIS} dependency with temperature and load current

Protection functions

- Stable behavior during undervoltage
- Reverse polarity protection with external components
- Secure load turn-off during logic ground disconnection with external components
- Overtemperature protection with latch
- Overvoltage protection with external components
- Enhanced short circuit operation

Product validation

Qualified for Automotive Applications.

Product validation according to AEC-Q100/101.

Table of contents

	Feature list	1
	Potential applications	1
	Product summary	2
	Product validation	2
	Table of contents	3
1	Description	5
2	Block diagram reference	6
3	Pin configuration	7
3.1	Pin assignment	7
3.2	Pin definitions and functions	7
3.3	Voltage and current definition	8
4	Electrical characteristics and parameters	9
4.1	Absolute maximum ratings	9
4.2	Functional range	11
4.3	Thermal resistance	12
4.3.1	PCB set-up	13
4.3.2	Thermal impedance	14
5	Power stage	15
5.1	Output ON-state resistance	15
5.2	Turn ON/OFF characteristics with resistive load	15
5.3	Inductive load	16
5.3.1	Output clamping	16
5.3.2	Maximum load inductance	17
5.4	Inverse current capability	17
5.5	Electrical characteristics - power stage	18
6	Protection functions	20
6.1	Loss of ground protection	20
6.2	Undervoltage protection	20
6.3	Overvoltage protection	21
6.4	Reverse polarity protection	22
6.5	Overload protection	23
6.5.1	Current limitation	23
6.5.2	Temperature limitation in the power DMOS	23
6.6	Electrical characteristics for the protection functions	25
7	Diagnostic functions	26
7.1	IS pin	26

Table of contents

7.2	SENSE signal in different operating modes	27
7.3	SENSE signal in nominal current range	28
7.3.1	SENSE signal variation as a function of temperature and load current	28
7.3.2	SENSE signal timing	30
7.3.3	SENSE signal in open load	30
7.3.3.1	Open load in ON diagnostic	30
7.3.3.2	Open load in OFF diagnostic	31
7.3.3.3	Open load diagnostic timing	32
7.3.4	SENSE signal in short circuit to V_S	33
7.3.5	SENSE signal in case of overload	34
7.3.6	SENSE signal in case of inverse current	34
7.4	Electrical characteristics diagnostic function	35
8	Input pins	39
8.1	Input circuitry	39
8.2	DEN / DSEL0, 1 pin	39
8.3	Input pin voltage	39
8.4	Electrical characteristics	39
9	Characterization results	41
9.1	General product characteristics	41
9.2	Power stage	42
9.3	Protection functions	44
9.4	Diagnostic mechanism	45
9.5	Input pins	46
10	Application information	47
10.1	Further application information	48
11	Package outlines	49
	Revision history	50
	Disclaimer	51

Description

1 Description

The BTT6200-4ESA is a 200 mΩ quad channel Smart High-Side Power Switch, embedded in a PG-TSDSO-24 package, providing protective functions and diagnosis.

The power transistor is built by an N-channel vertical power MOSFET with charge pump. The device is integrated in Smart6 HV technology. It is specially designed to drive lamps up to R10 W 24 V or R5 W 12 V, as well as LEDs in the harsh automotive environment.

Block diagram reference

2 Block diagram reference

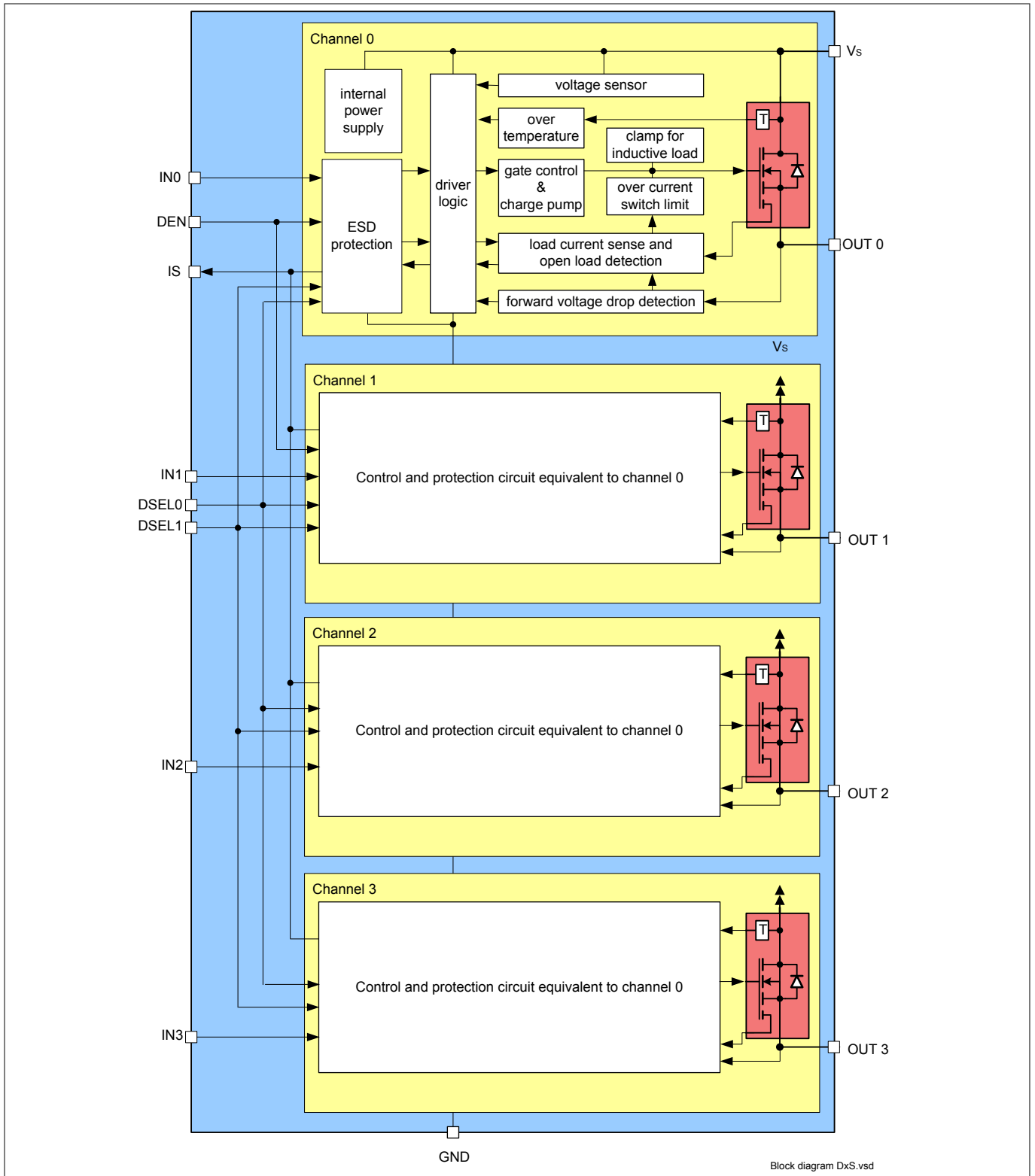

Figure 2 Block diagram for BTT6200-4ESA

Pin configuration

3 Pin configuration

3.1 Pin assignment

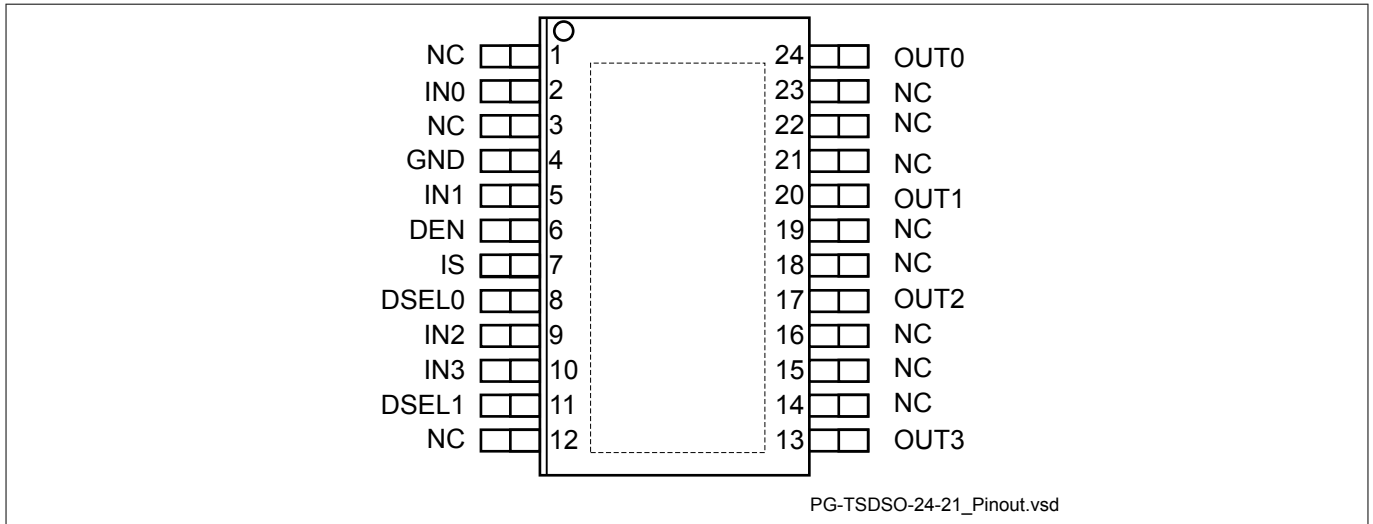

Figure 3 Pin configuration

3.2 Pin definitions and functions

Table 2 Pin definitions and functions

Pin	Symbol	Function
1, 3, 12, 14, 15, 16, 18, 19, 21, 22, 23	NC	Not Connected; No internal connection to the chip
2	IN0	INput channel 0; Input signal for channel 0 activation
4	GND	GrouND; Ground connection
5	IN1	INput channel 1; Input signal for channel 1 activation
6	DEN	Diagnostic ENable; Digital signal to enable/disable the diagnosis of the device
7	IS	Sense; Sense current of the selected channel
8	DSEL0	Diagnostic SElection; Digital signal to select the channel to be diagnosed
9	IN2	INput channel 2; Input signal for channel 2 activation
10	IN3	INput channel 3; Input signal for channel 3 activation
11	DSEL1	Diagnostic SElection; Digital signal to select the channel to be diagnosed
13	OUT3	OUTput 3; Protected high side power output channel 3
17	OUT2	OUTput 2; Protected high side power output channel 2
20	OUT1	OUTput 1; Protected high side power output channel 1

Pin configuration

Table 2 Pin definitions and functions (continued)

Pin	Symbol	Function
24	OUT0	OUTput 0; Protected high side power output channel 0
Cooling tab	VS	Voltage Supply; Battery voltage

3.3 Voltage and current definition

Figure 4 shows all terms used in this data sheet, with associated convention for positive values.

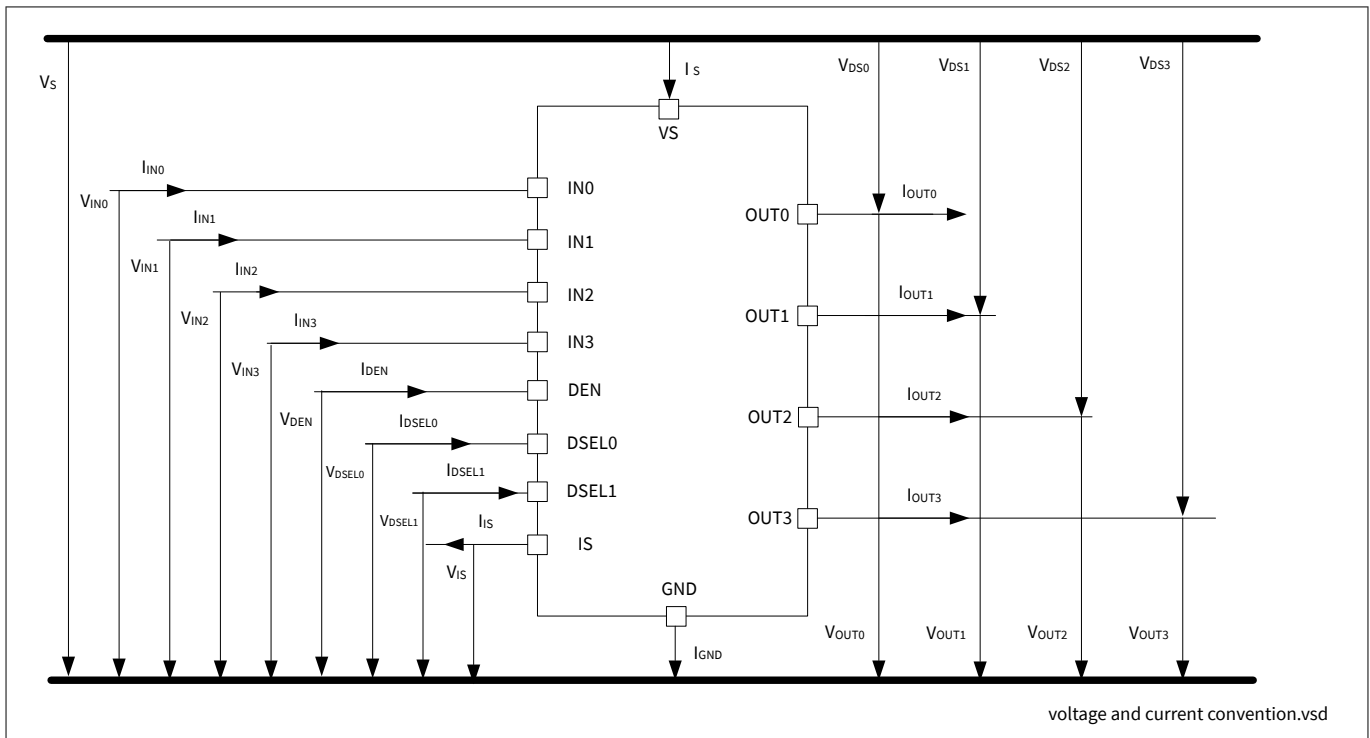

Figure 4 Voltage and current definition

Electrical characteristics and parameters

4 Electrical characteristics and parameters

4.1 Absolute maximum ratings

Table 3 Absolute maximum ratings¹⁾

$T_J = -40^\circ\text{C}$ to 150°C ; (unless otherwise specified)

Parameter	Symbol	Values			Unit	Note or Test Condition	Number
		Min.	Typ.	Max.			
Supply voltages							
Supply voltage	V_S	-0.3	–	48	V	–	P_4.1.1
Reverse polarity voltage	$-V_{S(\text{REV})}$	0	–	28	V	$t < 2$ min $T_A = 25^\circ\text{C}$ $R_L \geq 47 \Omega$ $Z_{\text{GND}} = \text{Diode} + 27 \Omega$	P_4.1.2
Supply voltage for short circuit protection	$V_{\text{BAT}(\text{SC})}$	0	–	36	V	$R_{\text{Supply}} = 10 \text{ m}\Omega$ $L_{\text{Supply}} = 5 \mu\text{H}$ $R_{\text{ECU}} = 20 \text{ m}\Omega$ $R_{\text{Cable}} = 16 \text{ m}\Omega/\text{m}$ $L_{\text{Cable}} = 1 \mu\text{H}/\text{m}$, $l = 0$ or 5 m See Chapter 6 and Figure 29	P_4.1.3
Supply voltage for Load dump protection	$V_{S(\text{LD})}$	–	–	65	V	²⁾ $R_I = 2 \Omega$ $R_L = 47 \Omega$	P_4.1.12
Short circuit capability							
Permanent short circuit IN pin toggles	n_{RSC1}	–	–	100	k cycles	³⁾ –	P_4.1.4
Input pins							
Voltage at INPUT pins	V_{IN}	-0.3 –	–	6 7	V	– $t < 2$ min	P_4.1.13
Current through INPUT pins	I_{IN}	-2	–	2	mA	–	P_4.1.14
Voltage at DEN pin	V_{DEN}	-0.3 –	–	6 7	V	– $t < 2$ min	P_4.1.15
Current through DEN pin	I_{DEN}	-2	–	2	mA	–	P_4.1.16

¹ Not subject to production test. Specified by design.

² $V_{S(\text{LD})}$ is setup without the DUT connected to the generator per ISO 7637-1.

³ Threshold limit for short circuit failures: 100 ppm. Please refer to the legal disclaimer for short-circuit capability at the end of this document.

Electrical characteristics and parameters

Table 3 Absolute maximum ratings¹⁾ (continued)

$T_J = -40^{\circ}\text{C}$ to 150°C ; (unless otherwise specified)

Parameter	Symbol	Values			Unit	Note or Test Condition	Number
		Min.	Typ.	Max.			
Voltage at DSEL pin	V_{DSEL}	-0.3 -	-	6 7	V	- $t < 2$ min	P_4.1.17
Current through DSEL pin	I_{DSEL}	-2	-	2	mA	-	P_4.1.18
Sense pin							
Voltage at IS pin	V_{IS}	-0.3	-	V_S	V	-	P_4.1.19
Current through IS pin	I_{IS}	-25	-	50	mA	-	P_4.1.20
Power stage							
Load current	$ I_L $	-	-	$I_{\text{L(LIM)}}$	A	-	P_4.1.21
Power dissipation (DC)	P_{TOT}	-	-	1.8	W	$T_A = 85^{\circ}\text{C}$ $T_J < 150^{\circ}\text{C}$	P_4.1.22
Maximum energy dissipation Single pulse (one channel)	E_{AS}	-	-	20	mJ	$I_{\text{L(0)}} = 1$ A $T_{\text{J(0)}} = 150^{\circ}\text{C}$ $V_S = 28$ V	P_4.1.23
Voltage at power transistor	V_{DS}	-	-	65	V	-	P_4.1.26
Currents							
Current through ground pin	I_{GND}	-20 -150	-	20 20	mA	- $t < 2$ min	P_4.1.27
Temperatures							
Junction temperature	T_J	-40	-	150	$^{\circ}\text{C}$	-	P_4.1.28
Storage temperature	T_{STG}	-55	-	150	$^{\circ}\text{C}$	-	P_4.1.30
ESD susceptibility							
ESD susceptibility (all pins)	V_{ESD}	-2	-	2	kV	⁴⁾ HBM	P_4.1.31
ESD susceptibility OUT pin vs. GND and V_S connected	V_{ESD}	-4	-	4	kV	⁴⁾ HBM	P_4.1.32
ESD susceptibility	V_{ESD}	-500	-	500	V	⁵⁾ CDM	P_4.1.33
ESD susceptibility pin (corner pins)	V_{ESD}	-750	-	750	V	⁵⁾ CDM	P_4.1.34

Notes:

1. Stresses above the ones listed here may cause permanent damage to the device. Exposure to absolute maximum rating conditions for extended periods may affect device reliability.

¹ Not subject to production test. Specified by design.

⁴ ESD susceptibility Human Body Model "HBM" according to AEC Q100-002

⁵ ESD susceptibility Charged Device Model "CDM" according to AEC Q100-011

Electrical characteristics and parameters

2. *Integrated protection functions are designed to prevent IC destruction under fault conditions described in the data sheet. Fault conditions are considered as “outside” normal operating range. Protection functions are not designed for continuous repetitive operation.*

4.2 Functional range

Table 4 Functional range

$T_J = -40^\circ\text{C}$ to 150°C ; (unless otherwise specified)

Parameter	Symbol	Values			Unit	Note or Test Condition	Number
		Min.	Typ.	Max.			
Nominal operating voltage	V_{NOM}	8	28	36	V	–	P_4.2.1
Extended operating voltage	$V_{\text{S(OP)}}$	5	–	48	V	⁷⁾ $V_{\text{IN}} = 4.5\text{ V}$ $R_{\text{L}} = 47\ \Omega$ $V_{\text{DS}} < 0.5\text{ V}$	P_4.2.2
Minimum functional supply voltage	$V_{\text{S(OP)_MIN}}$	3.8	4.3	5	V	⁶⁾ $V_{\text{IN}} = 4.5\text{ V}$ $R_{\text{L}} = 47\ \Omega$ From $I_{\text{OUT}} = 0\text{ A}$ to $V_{\text{DS}} < 0.5\text{ V}$; see Figure 16	P_4.2.3
Undervoltage shutdown	$V_{\text{S(UV)}}$	3	3.5	4.1	V	⁶⁾ $V_{\text{IN}} = 4.5\text{ V}$ $V_{\text{DEN}} = 0\text{ V}$ $R_{\text{L}} = 47\ \Omega$ From $V_{\text{DS}} < 1\text{ V}$; to $I_{\text{OUT}} = 0\text{ A}$ See Chapter 9.1 and Figure 16	P_4.2.4
Undervoltage shutdown hysteresis	$V_{\text{S(UV)_HYS}}$	–	850	–	mV	⁷⁾ –	P_4.2.13
Operating current One channel active	I_{GND_1}	–	2	4	mA	$V_{\text{IN}} = 5.5\text{ V}$ $V_{\text{DEN}} = 5.5\text{ V}$ Device in $R_{\text{DS(ON)}}$ $V_{\text{S}} = 36\text{ V}$ See Chapter 9.1	P_4.2.5

⁷ Not subject to production test. Specified by design.

⁶ Test at $T_J = -40^\circ\text{C}$ only.

Electrical characteristics and parameters

Table 4 Functional range (continued)

$T_J = -40^\circ\text{C}$ to 150°C ; (unless otherwise specified)

Parameter	Symbol	Values			Unit	Note or Test Condition	Number
		Min.	Typ.	Max.			
Operating current All channels active	I_{GND_4}	–	6	9	mA	$V_{\text{IN}} = 5.5\text{ V}$ $V_{\text{DEN}} = 5.5\text{ V}$ Device in $R_{\text{DS(ON)}}$ $V_{\text{S}} = 36\text{ V}$ See Chapter 9.1	P_4.2.6
Standby current for whole device with load (ambient)	$I_{\text{S(OFF)}}$	–	0.1	0.5	μA	⁶⁾ $V_{\text{S}} = 36\text{ V}$ $V_{\text{OUT}} = 0\text{ V}$ V_{IN} floating V_{DEN} floating $T_J \leq 85^\circ\text{C}$	P_4.2.7
Maximum standby current for whole device with load	$I_{\text{S(OFF)}_{150}}$	–	–	20	μA	$V_{\text{S}} = 36\text{ V}$ $V_{\text{OUT}} = 0\text{ V}$ V_{IN} floating V_{DEN} floating $T_J = 150^\circ\text{C}$	P_4.2.10
Standby current for whole device with load, diagnostic active	$I_{\text{S(OFF_DEN)}}$	–	0.6	–	mA	⁷⁾ $V_{\text{S}} = 36\text{ V}$ $V_{\text{OUT}} = 0\text{ V}$ V_{IN} floating $V_{\text{DEN}} = 5.5\text{ V}$	P_4.2.8

Note: Within the functional range the IC operates as described in the circuit description. The electrical characteristics are specified within the conditions given in the related electrical characteristics table.

4.3 Thermal resistance

Table 5 Thermal resistance

Parameter	Symbol	Values			Unit	Note or Test Condition	Number
		Min.	Typ.	Max.			
Junction to case	R_{thJC}	–	3	–	K/W	⁸⁾	P_4.3.1
Junction to ambient All channels active	R_{thJA}	–	28	–	K/W	⁸⁾⁹⁾	P_4.3.2

⁶ Test at $T_J = -40^\circ\text{C}$ only.

⁷ Not subject to production test. Specified by design.

⁸ Not subject to production test. Specified by design.

Electrical characteristics and parameters

4.3.1 PCB set-up

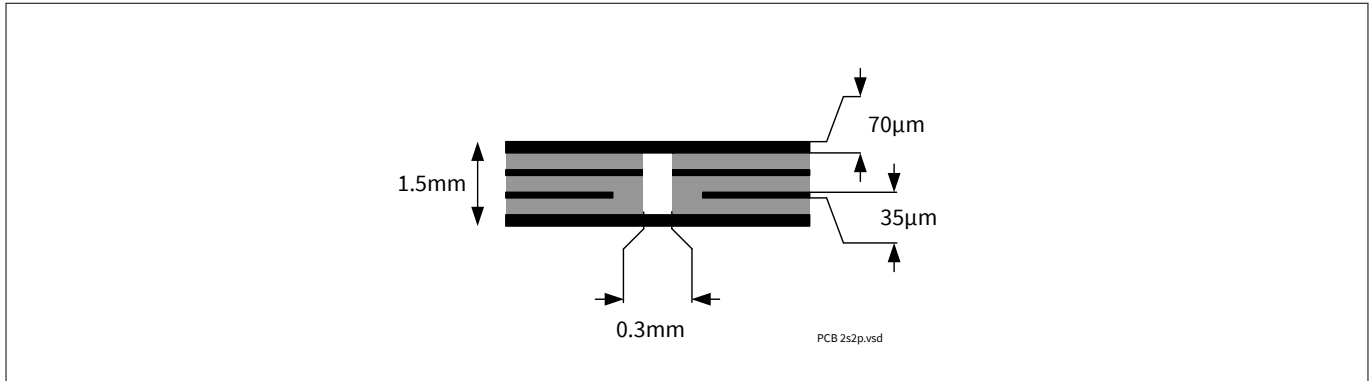

Figure 5 2s2p PCB cross section

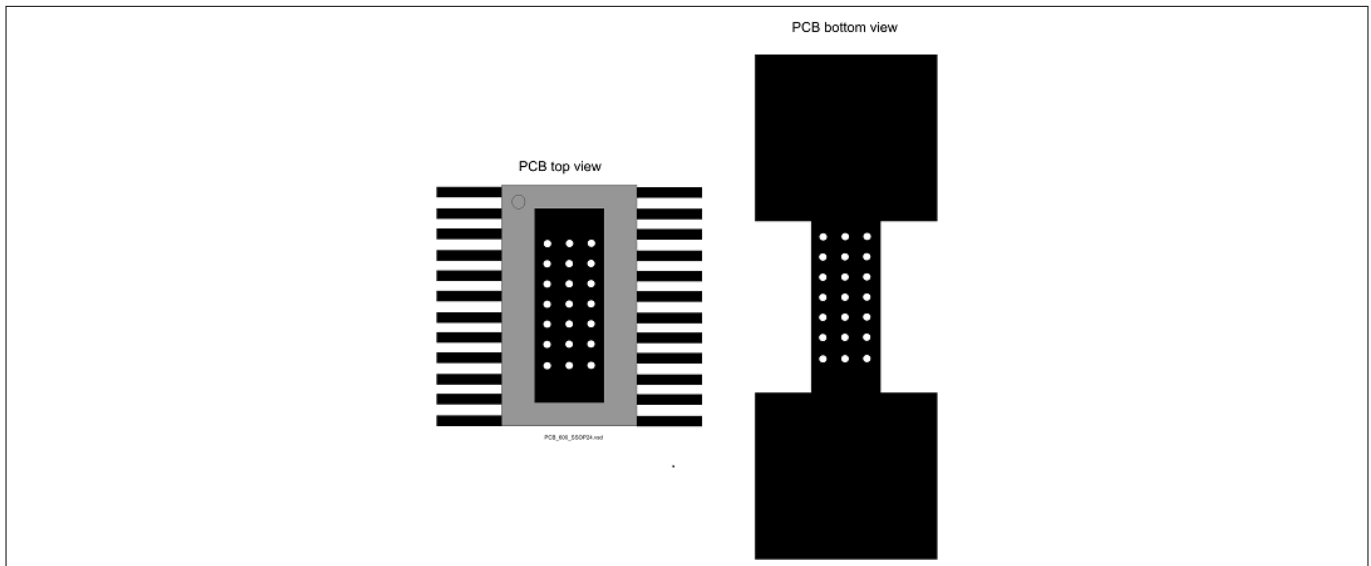

Figure 6 PC board top and bottom view for thermal simulation with 600 mm² cooling area

⁹ Specified R_{thja} value is according to JEDEC JESD51-2,-5,-7 at natural convection on FR4 2s2p board with 1 W power dissipation equally dissipated for all channel at $T_A = 105^\circ\text{C}$; The product (chip + package) was simulated on a 76.4 mm x 114.3 mm x 1.5 mm board with 2 inner copper layers (2 x 70 µm Cu, 2 x 35 µm Cu). Where applicable, a thermal via array under the exposed pad contacts the first inner copper layer. Please refer to [Figure 5](#).

Electrical characteristics and parameters

4.3.2 Thermal impedance

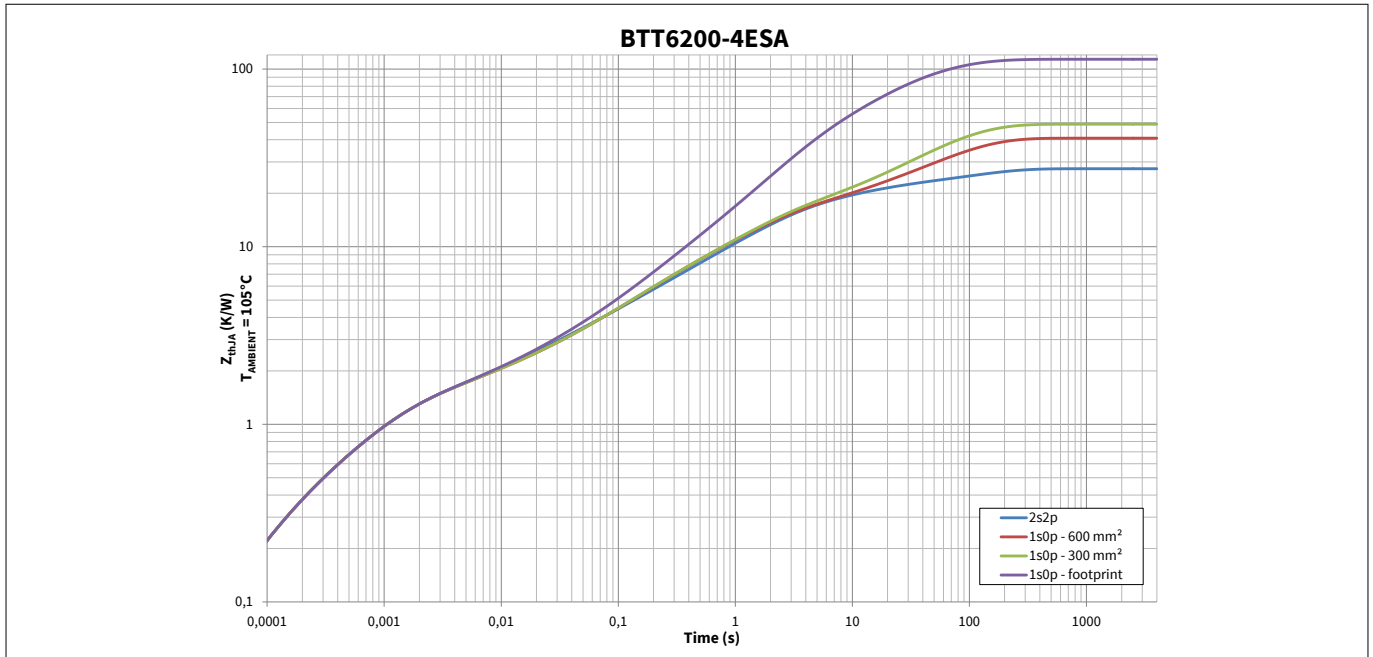

Figure 7 Typical thermal impedance. 2s2p PCB set-up according to Figure 5

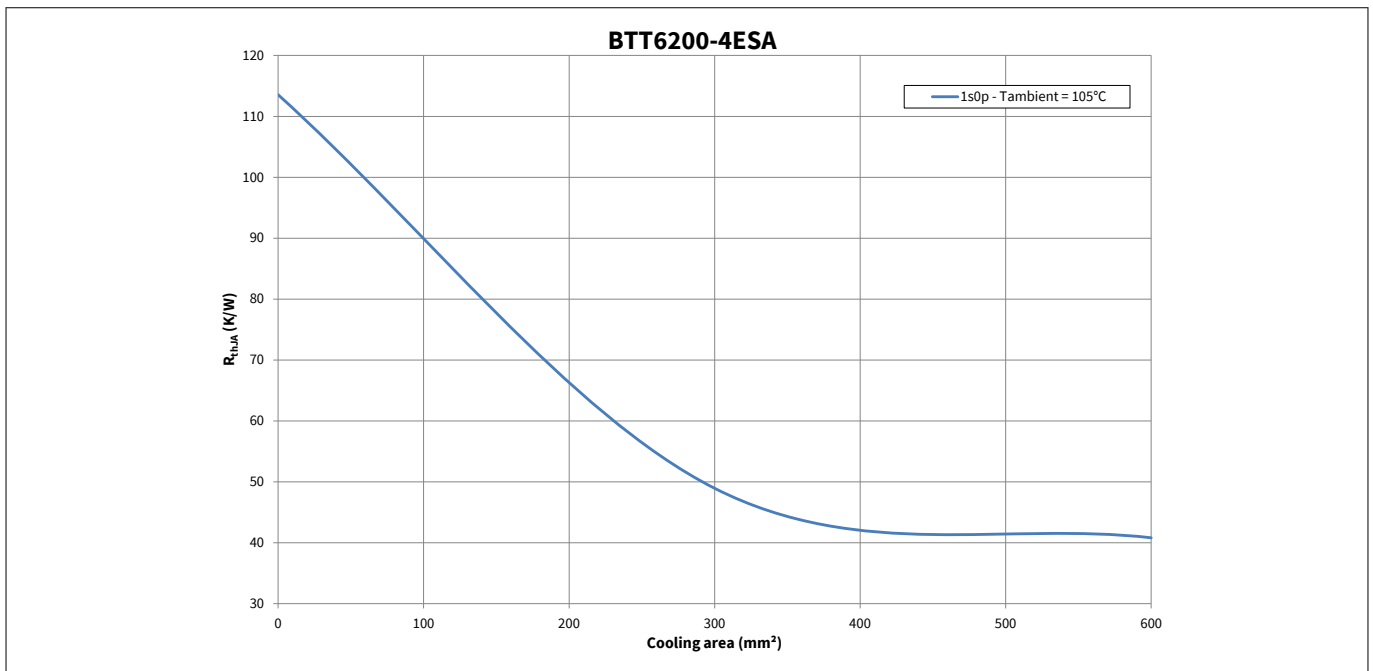

Figure 8 Typical thermal resistance. PCB set-up 1s0p

Power stage

5 Power stage

The power stages are built using an N-channel vertical power MOSFET (DMOS) with charge pump.

5.1 Output ON-state resistance

The ON-state resistance $R_{DS(ON)}$ depends on the supply voltage as well as the junction temperature T_J . **Figure 9** shows the dependencies in terms of temperature and supply voltage for the typical ON-state resistance. The behavior in reverse polarity is described in **Chapter 6.4**.

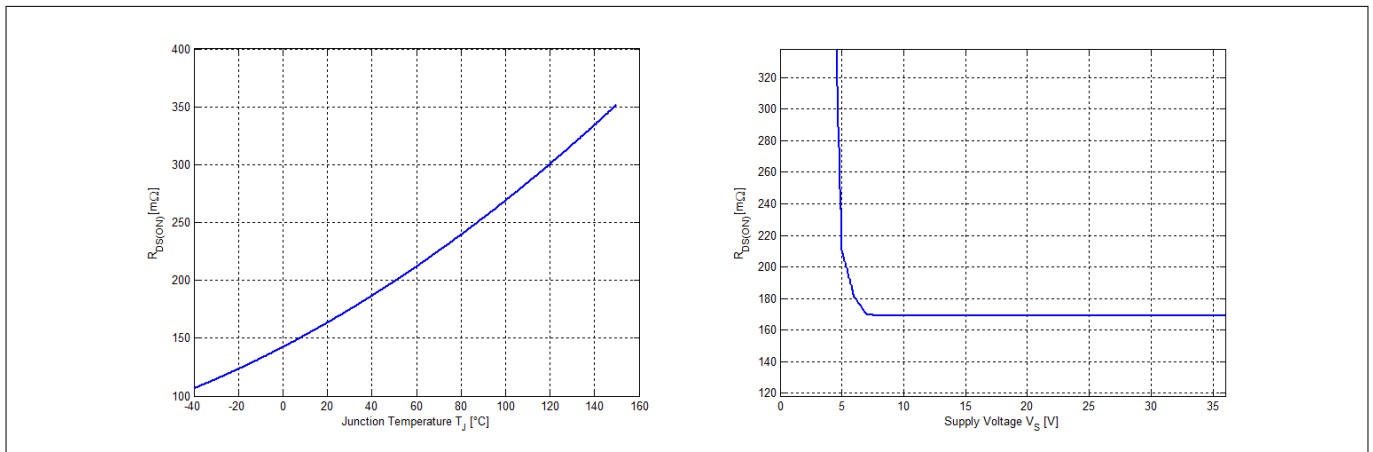

Figure 9 Typical ON-state resistance

A high signal at the input pin (see **Chapter 8**) causes the power DMOS to switch ON with a dedicated slope, which is optimized in terms of EMC emission.

5.2 Turn ON/OFF characteristics with resistive load

Figure 10 shows the typical timing when switching a resistive load.

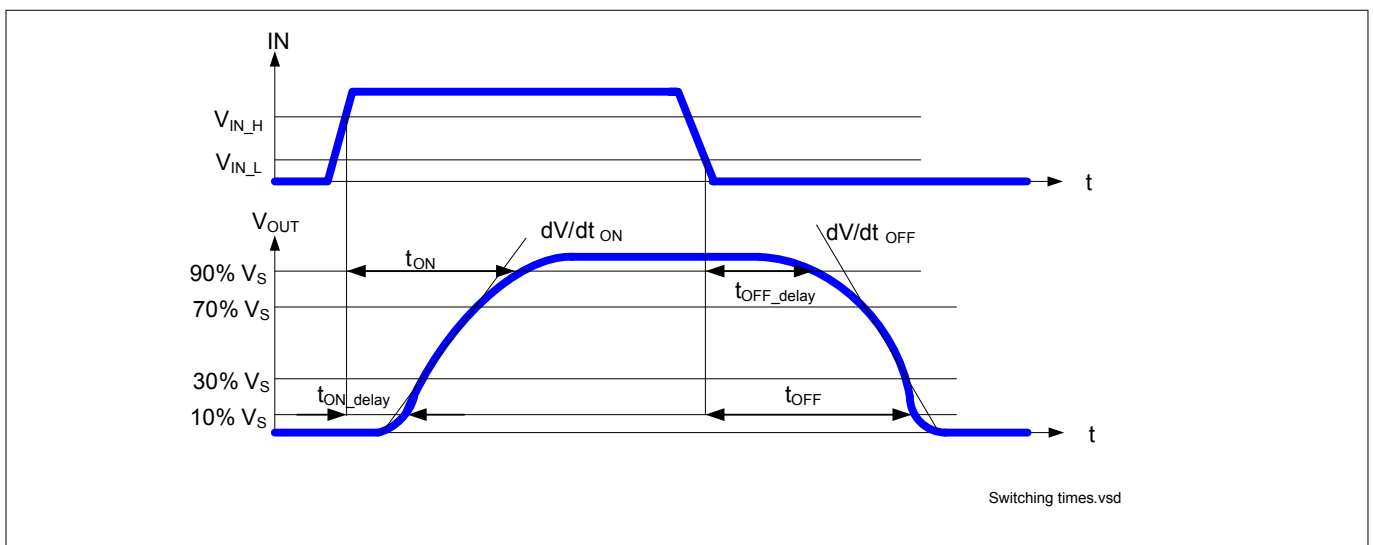

Figure 10 Switching a resistive load timing

Power stage

5.3 Inductive load

5.3.1 Output clamping

When switching OFF inductive loads with high side switches, the voltage V_{OUT} drops below ground potential, because the inductance intends to continue driving the current. To prevent the destruction of the device by avalanche due to high voltages, there is a voltage clamp mechanism $Z_{DS(AZ)}$ implemented that limits negative output voltage to a certain level ($V_S - V_{DS(AZ)}$). Please refer to [Figure 11](#) and [Figure 12](#) for details. Nevertheless, the maximum allowed load inductance is limited.

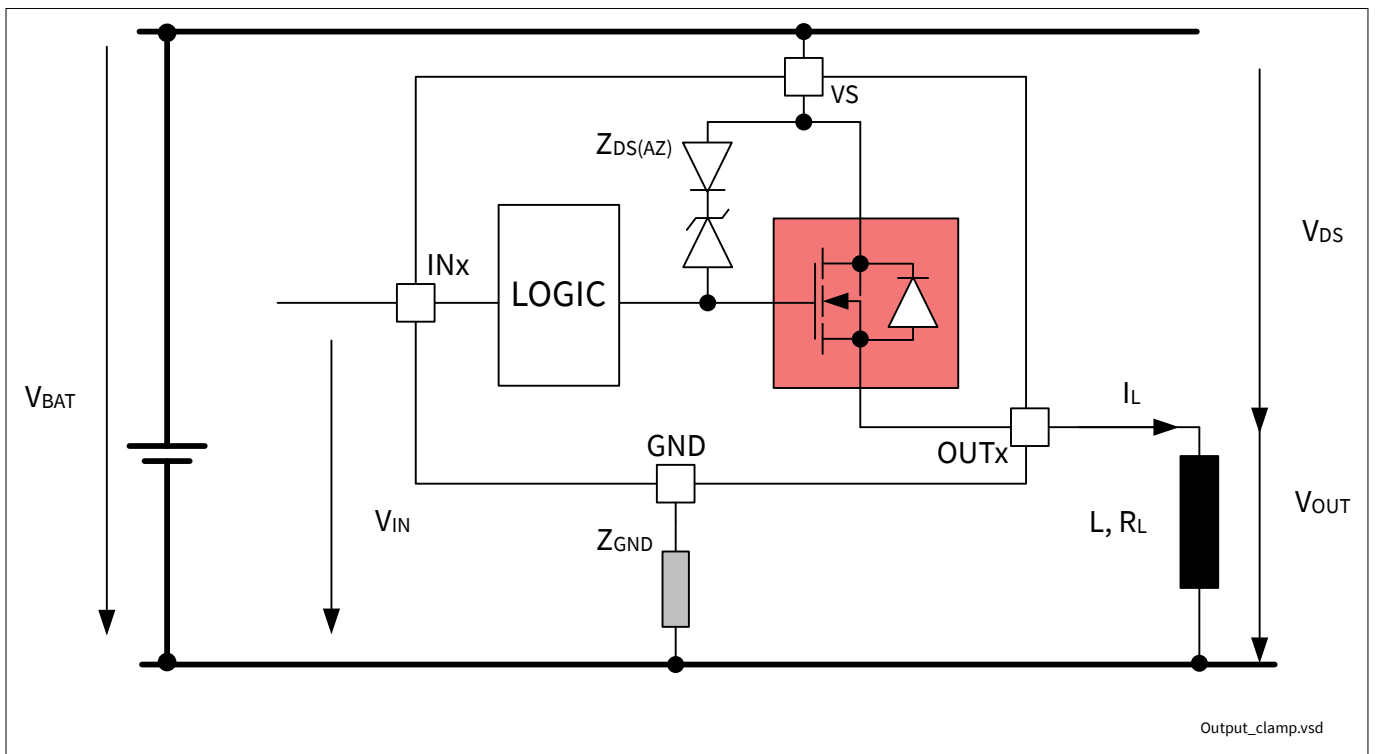

Figure 11 Output clamp

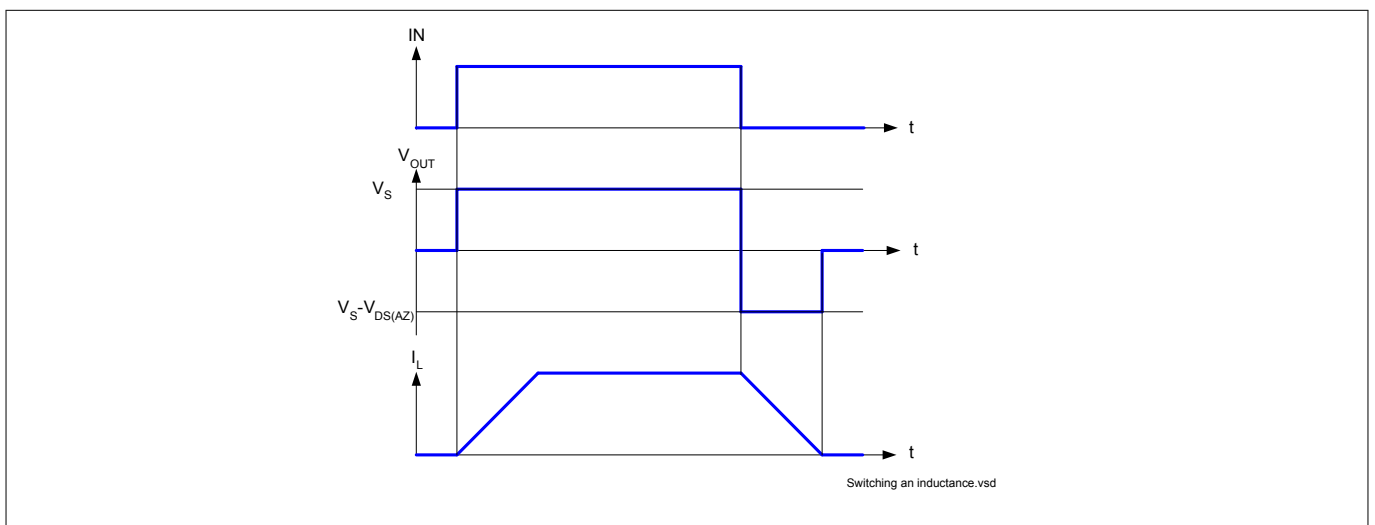

Figure 12 Switching an inductive load timing

Power stage

5.3.2 Maximum load inductance

During demagnetization of inductive loads, energy has to be dissipated in the BTT6200-4ESA. This energy can be calculated with following equation:

$$E = V_{DS(AZ)} \cdot \frac{L}{R_L} \cdot \left[\frac{V_S - V_{DS(AZ)}}{R_L} \cdot \ln \left(1 - \frac{R_L \cdot I_L}{V_S - V_{DS(AZ)}} \right) + I_L \right]$$

Equation 1

The following equation simplifies under the assumption of $R_L = 0 \Omega$.

$$E = \frac{1}{2} \cdot L \cdot I^2 \cdot \left(1 - \frac{V_S}{V_S - V_{DS(AZ)}} \right)$$

Equation 2

The energy, which is converted into heat, is limited by the thermal design of the component. See [Figure 13](#) for the maximum allowed energy dissipation as a function of the load current.

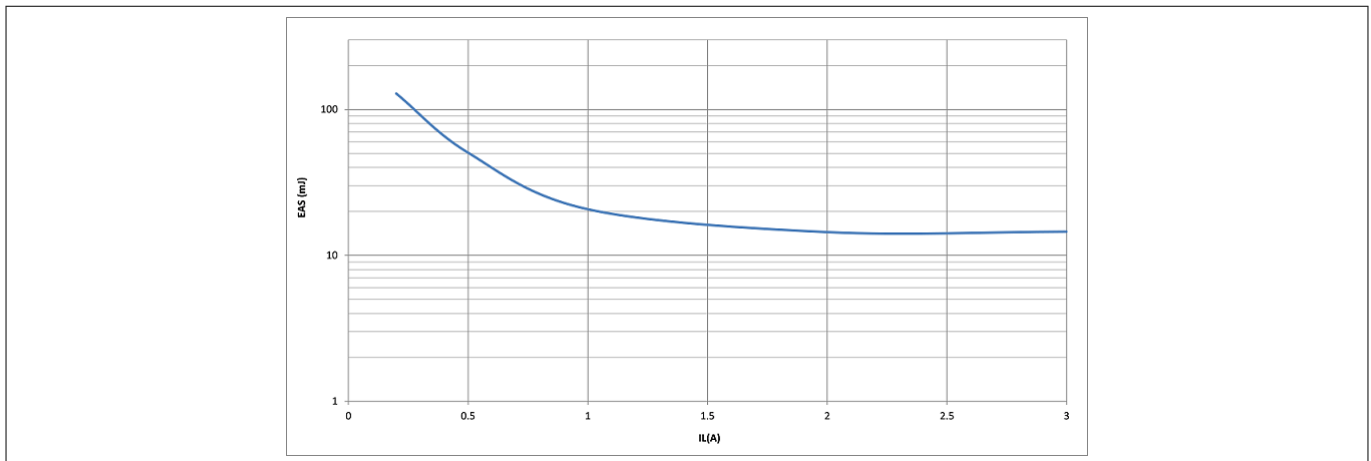

Figure 13 Maximum energy dissipation single pulse, $T_{J_START} = 150^\circ\text{C}$; $V_S = 28 \text{ V}$

5.4 Inverse current capability

In case of inverse current, meaning a voltage V_{INV} at the OUTput higher than the supply voltage V_S , a current I_{INV} will flow from output to V_S pin via the body diode of the power transistor (please refer to [Figure 14](#)). The output stage follows the state of the IN pin, except if the IN pin goes from OFF to ON during inverse. In that particular case, the output stage is kept OFF until the inverse current disappears. Nevertheless, the current I_{INV} should not be higher than $I_{L(INV)}$. If the channel is OFF, the diagnostic will detect an open load at OFF. If the affected channel is ON, the diagnostic will detect open load at ON (the overtemperature signal is inhibited). At the appearance of V_{INV} , a parasitic diagnostic can be observed. After, the diagnosis is valid and reflects the output state. At V_{INV} vanishing, the diagnosis is valid and reflects the output state. During inverse current, no protection functions are available.

Power stage

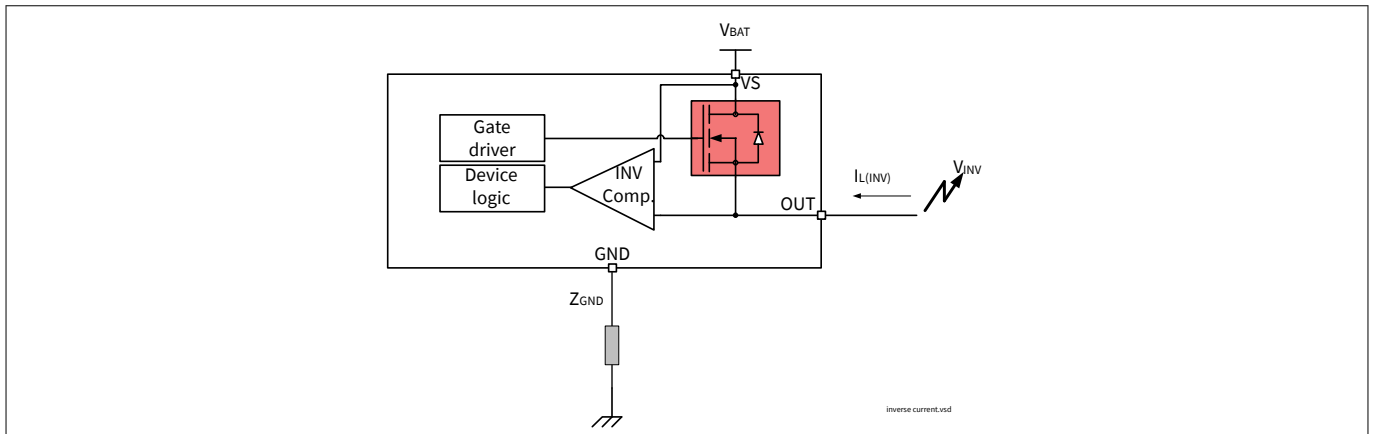

Figure 14 Inverse current circuitry

5.5 Electrical characteristics - power stage

Table 6 Electrical characteristics: Power stage

$V_S = 8\text{ V to }36\text{ V}$, $T_J = -40^\circ\text{C to }150^\circ\text{C}$ (unless otherwise specified).

Typical values are given at $V_S = 28\text{ V}$, $T_J = 25^\circ\text{C}$

Parameter	Symbol	Values			Unit	Note or Test Condition	Number
		Min.	Typ.	Max.			
ON-state resistance per channel	$R_{DS(ON)_{150}}$	300	360	400	mΩ	$I_L = I_{L4} = 1\text{ A}$ $V_{IN} = 4.5\text{ V}$ $T_J = 150^\circ\text{C}$ See Figure 9	P_5.5.1
ON-state resistance per channel	$R_{DS(ON)_{25}}$	–	200	–	mΩ	¹⁰⁾ $T_J = 25^\circ\text{C}$	P_5.5.21
Nominal load current One channel active	$I_{L(NOM)1}$	–	1.5	–	A	¹⁰⁾ $T_A = 85^\circ\text{C}$ $T_J < 150^\circ\text{C}$	P_5.5.2
Nominal load current All channels active	$I_{L(NOM)2}$	–	1	–	A		P_5.5.3
Output voltage drop limitation at small load currents	$V_{DS(NL)}$	–	10	22	mV	$I_L = I_{L0} = 25\text{ mA}$ See Chapter 9.3	P_5.5.4
Drain to source clamping voltage $V_{DS(AZ)} = [V_S - V_{OUT}]$	$V_{DS(AZ)}$	65	70	75	V	$I_{DS} = 5\text{ mA}$ See Figure 12 See Chapter 9.1	P_5.5.5
Output leakage current per channel $T_J \leq 85^\circ\text{C}$	$I_{L(OFF)}$	–	0.1	0.5	μA	¹¹⁾ V_{IN} floating $V_{OUT} = 0\text{ V}$ $T_J \leq 85^\circ\text{C}$	P_5.5.6

¹⁰⁾ Not subject to production test, specified by design.

¹¹⁾ Test at $T_J = -40^\circ\text{C}$ only

Power stage

Table 6 Electrical characteristics: Power stage (continued)

$V_S = 8\text{ V to }36\text{ V}$, $T_J = -40^\circ\text{C to }150^\circ\text{C}$ (unless otherwise specified).

Typical values are given at $V_S = 28\text{ V}$, $T_J = 25^\circ\text{C}$

Parameter	Symbol	Values			Unit	Note or Test Condition	Number
		Min.	Typ.	Max.			
Output leakage current per channel $T_J = 150^\circ\text{C}$	$I_{L(OFF)_150}$	–	1	5	μA	V_{IN} floating $V_{OUT} = 0\text{ V}$ $T_J = 150^\circ\text{C}$	P_5.5.8
Inverse current capability	$I_{L(INV)}$	–	1	–	A	¹⁰⁾ $V_S < V_{OUTX}$ See Figure 14	P_5.5.9
Slew rate 30% to 70% V_S	dV/dt_{ON}	0.3	0.8	1.3	$\text{V}/\mu\text{s}$	$R_L = 47\ \Omega$ $V_S = 28\text{ V}$	P_5.5.11
Slew rate 70% to 30% V_S	$-dV/dt_{OFF}$	0.3	0.8	1.3	$\text{V}/\mu\text{s}$	See Figure 10 See Chapter 9.1	P_5.5.12
Slew rate matching $dV/dt_{ON} - dV/dt_{OFF}$	$\Delta dV/dt$	-0.15	0	0.15	$\text{V}/\mu\text{s}$		P_5.5.13
Turn-ON time to $V_{OUT} = 90\% V_S$	t_{ON}	20	70	150	μs		P_5.5.14
Turn-OFF time to $V_{OUT} = 10\% V_S$	t_{OFF}	20	70	150	μs		P_5.5.15
Turn-ON / OFF matching $t_{OFF} - t_{ON}$	Δt_{SW}	-50	0	50	μs		P_5.5.16
Turn-ON time to $V_{OUT} = 10\% V_S$	t_{ON_delay}	–	35	70	μs		P_5.5.17
Turn-OFF time to $V_{OUT} = 90\% V_S$	t_{OFF_delay}	–	35	70	μs		P_5.5.18
Switch ON energy	E_{ON}	–	190	–	μJ	¹⁰⁾ $R_L = 47\ \Omega$ $V_{OUT} = 90\% V_S$ $V_S = 36\text{ V}$ See Chapter 9.1	P_5.5.19
Switch OFF energy	E_{OFF}	–	210	–	μJ	¹⁰⁾ $R_L = 47\ \Omega$ $V_{OUT} = 10\% V_S$ $V_S = 36\text{ V}$ See Chapter 9.1	P_5.5.20

¹⁰⁾ Not subject to production test, specified by design.

Protection functions

6 Protection functions

The device provides integrated protection functions. These functions are designed to prevent the destruction of the IC from fault conditions described in the data sheet. Fault conditions are considered as “outside” normal operating range. Protection functions are designed for neither continuous nor repetitive operation.

6.1 Loss of ground protection

In case of loss of the module ground and the load remains connected to ground, the device protects itself by automatically turning OFF (when it was previously ON) or remains OFF, regardless of the voltage applied on IN pins.

In case of loss of device ground, it’s recommended to use input resistors between the microcontroller and the BTT6200-4ESA to ensure switching OFF of channels.

In case of loss of module or device ground, a current ($I_{OUT(GND)}$) can flow out of the DMOS. **Figure 15** sketches the situation.

Z_{GND} is recommended to be a resistor in series to a diode .

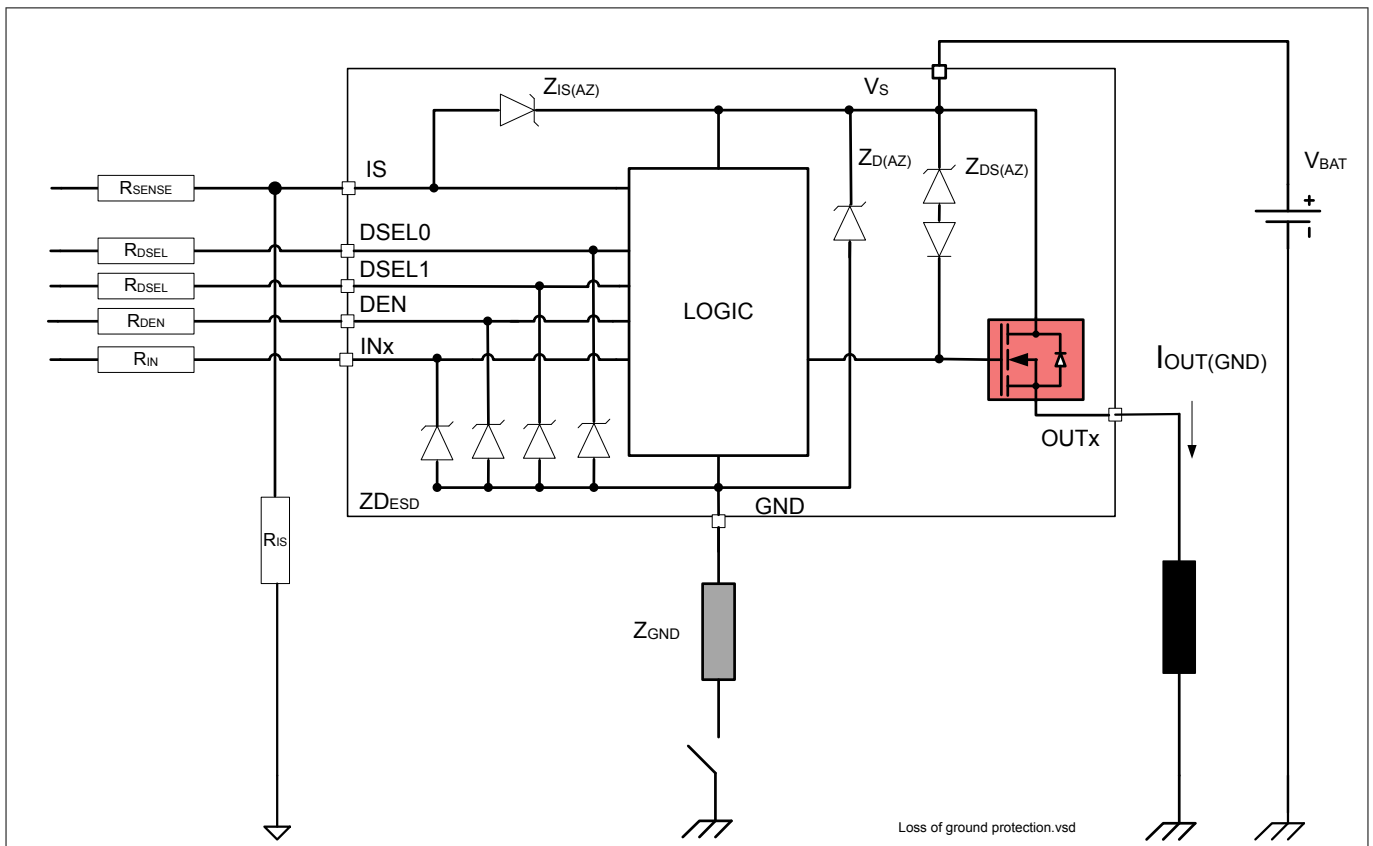

Figure 15 Loss of ground protection with external components

6.2 Undervoltage protection

Between $V_{S(UV)}$ and $V_{S(OP)}$, the undervoltage mechanism is triggered. $V_{S(OP)}$ represents the minimum voltage where the switching ON and OFF can take place. $V_{S(UV)}$ represents the minimum voltage the switch can hold ON. If the supply voltage is below the undervoltage mechanism $V_{S(UV)}$, the device is OFF (turns OFF). As soon as the supply voltage is above the undervoltage mechanism $V_{S(OP)}$, then the device can be switched ON. When the switch is ON, protection functions are operational. Nevertheless, the diagnosis is not guaranteed until V_S is in the V_{NOM} range. **Figure 16** illustrates the undervoltage mechanism.

Protection functions

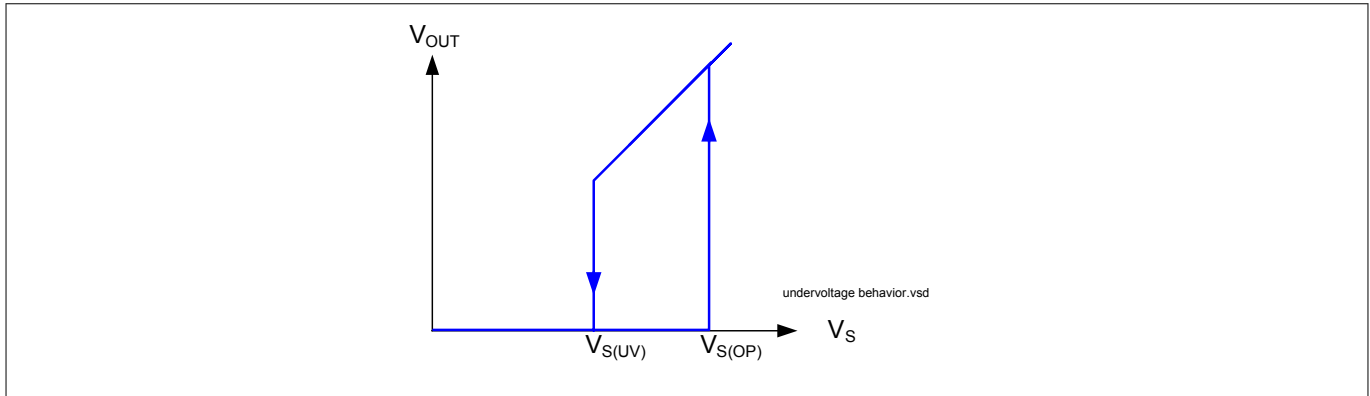

Figure 16 **Undervoltage behavior**

6.3 **Overvoltage protection**

There is an integrated clamp mechanism for overvoltage protection ($Z_{D(AZ)}$). To guarantee this mechanism operates properly in the application, the current in the Zener diode has to be limited by a ground resistor. **Figure 17** shows a typical application to withstand overvoltage issues. In case of supply voltage higher than $V_{S(AZ)}$, the power transistor switches ON and in addition the voltage across the logic section is clamped. As a result, the internal ground potential rises to $V_S - V_{S(AZ)}$. Due to the ESD Zener diodes, the potential at pin INx, DSELx, and DEN rises almost to that potential, depending on the impedance of the connected circuitry. In the case the device was ON, prior to overvoltage, the BTT6200-4ESA remains ON. In the case the BTT6200-4ESA was OFF, prior to overvoltage, the power transistor can be activated. In the case the supply voltage is in above $V_{BAT(SC)}$ and below $V_{DS(AZ)}$, the output transistor is still operational and follows the input. If at least one channel is in the ON state, parameters are no longer guaranteed and lifetime is reduced compared to the nominal supply voltage range. This especially impacts the short circuit robustness, as well as the maximum energy E_{AS} capability. Z_{GND} is recommended to be a resistor in series to a diode.

Protection functions

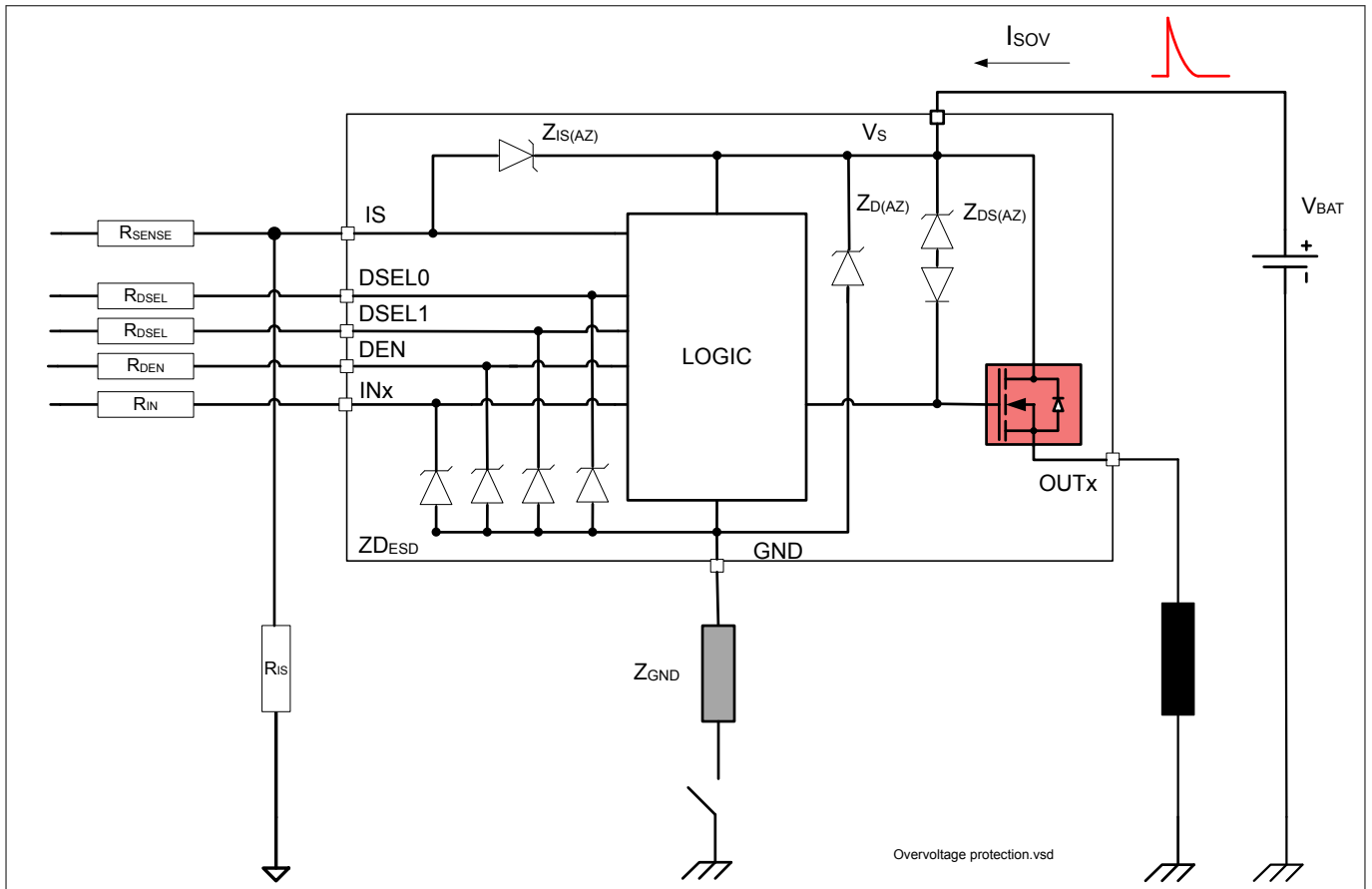

Figure 17 **Overvoltage protection with external components**

6.4 **Reverse polarity protection**

In case of reverse polarity, the intrinsic body diodes of the power DMOS causes power dissipation. The current in this intrinsic body diode is limited by the load itself. Additionally, the current into the ground path and the logic pins has to be limited to the maximum current described in **Chapter 4.1** with an external resistor. **Figure 18** shows a typical application. R_{GND} resistor is used to limit the current in the Zener protection of the device. Resistors R_{DSEL} , R_{DEN} , and R_{IN} are used to limit the current in the logic of the device and in the ESD protection stage. R_{SENSE} is used to limit the current in the sense transistor which behaves as a diode. The recommended value for $R_{DEN} = R_{DSEL} = R_{IN} = R_{SENSE} = 10\text{ k}\Omega$. It is recommended to use a resistor in series to a diode in the ground path.

During reverse polarity, no protection functions are available.

Protection functions

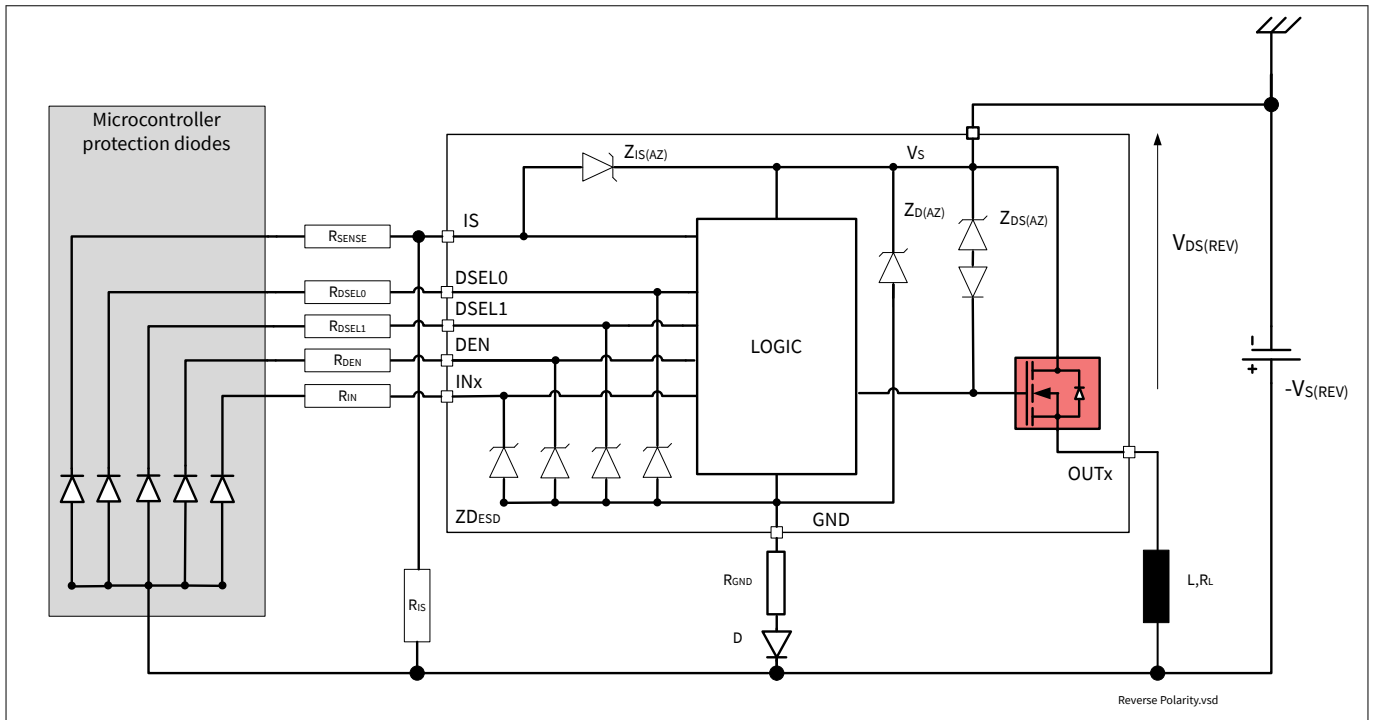

Figure 18 Reverse polarity protection with external components

6.5 Overload protection

In case of overload, such as high inrush of cold lamp filament, or short circuit to ground, the BTT6200-4ESA offers several protection mechanisms.

6.5.1 Current limitation

At first step, the instantaneous power in the switch is maintained at a safe value by limiting the current to the maximum current allowed in the switch $I_{L(SC)}$. During this time, the DMOS temperature increases, which affects the current flowing in the DMOS.

6.5.2 Temperature limitation in the power DMOS

Each channel incorporates both an absolute ($T_{J(SC)}$) and a dynamic ($T_{J(SW)}$) temperature sensor. Activation of either sensor will cause an overheated channel to switch OFF to prevent destruction. Any protective switch OFF latches the output until the temperature has reached an acceptable value which is depicted in [Figure 19](#).

No retry strategy is implemented such that when the DMOS temperature has cooled down enough, the switch is switched ON again. Only the IN pin signal toggling can re-activate the power stage (latch behavior).

Protection functions

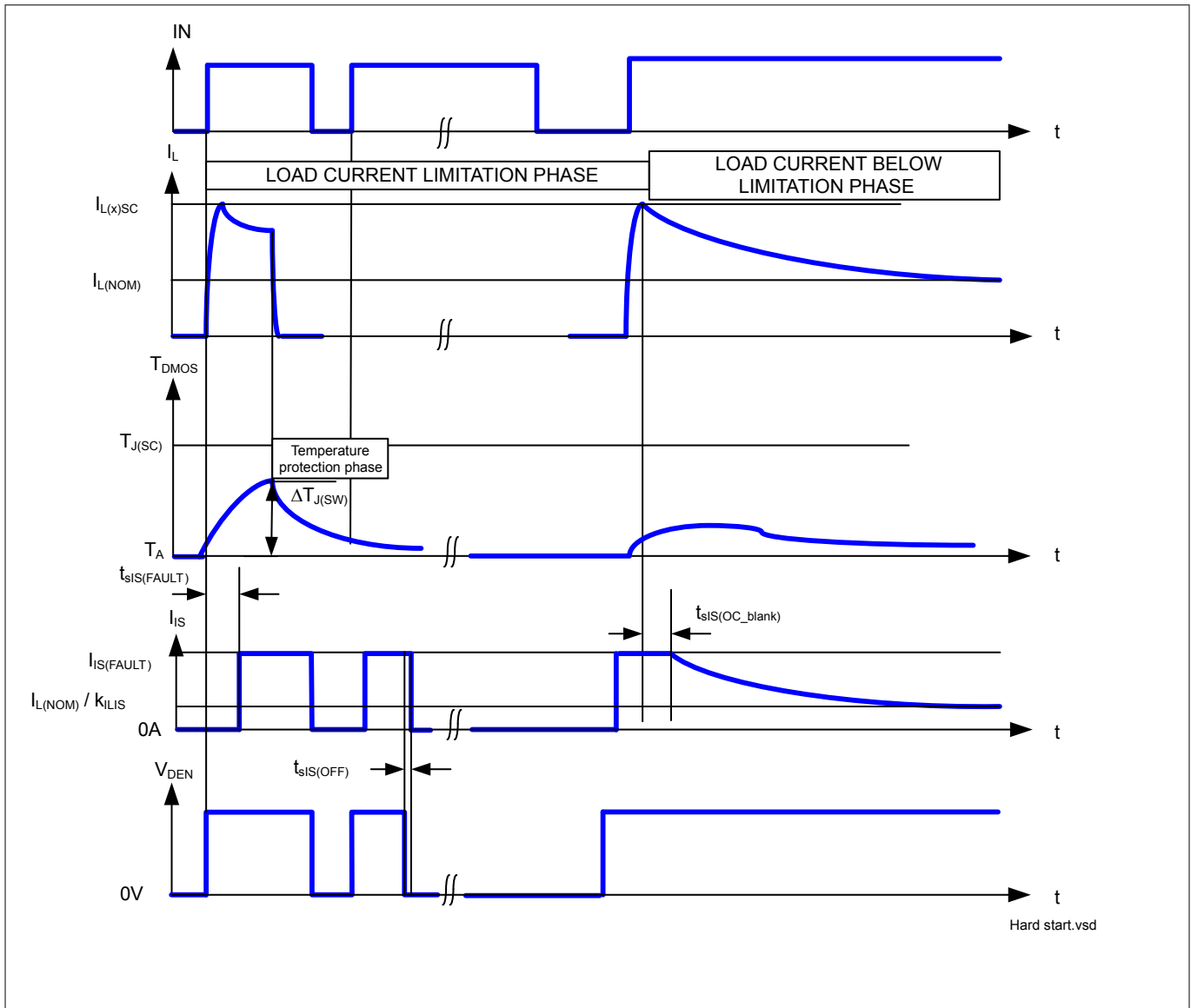

Figure 19 **Overload protection**

Note: For better understanding, the time scale is not linear. The real timing of this drawing is application dependant and cannot be described.

Protection functions

6.6 Electrical characteristics for the protection functions

Table 7 Electrical Characteristics: Protection

$V_S = 8\text{ V to }36\text{ V}$, $T_J = -40^\circ\text{C to }150^\circ\text{C}$, (unless otherwise specified).

Typical values are given at $V_S = 28\text{ V}$, $T_J = 25^\circ\text{C}$

Parameter	Symbol	Values			Unit	Note or Test Condition	Number
		Min.	Typ.	Max.			
Loss of ground							
Output leakage current while GND disconnected	$I_{OUT(GND)}$	–	0.1	–	mA	¹²⁾¹³⁾ $V_S = 28\text{ V}$ See Figure 15	P_6.6.1
Reverse polarity							
Drain source diode voltage during reverse polarity	$V_{DS(REV)}$	200	650	700	mV	¹⁴⁾ $I_L = -1\text{ A}$ See Figure 18	P_6.6.2
Overvoltage							
Overvoltage protection	$V_{S(AZ)}$	65	70	75	V	$I_{SOV} = 5\text{ mA}$ See Figure 17	P_6.6.3
Overload condition							
Load current limitation	$I_{L5(SC)}$	9	11	14	A	¹⁵⁾ $V_{DS} = 5\text{ V}$ See Figure 19 and Chapter 9.3	P_6.6.4
Dynamic temperature increase while switching	$\Delta T_{J(SW)}$	–	80	–	K	¹⁶⁾ See Figure 19	P_6.6.8
Thermal shutdown temperature	$T_{J(SC)}$	150	170	200	°C	¹⁴⁾ See Figure 19	P_6.6.10
Thermal shutdown hysteresis	$\Delta T_{J(SC)}$	–	30	–	K	¹³⁾	P_6.6.11

¹² All pins are disconnected except V_S and OUT.
¹³ Not Subject to production test, specified by design.
¹⁴ Test at $T_J = +150^\circ\text{C}$ only.
¹⁵ Test at $T_J = -40^\circ\text{C}$ only.
¹⁶ Functional test only

Diagnostic functions

7 Diagnostic functions

For diagnosis purposes, the BTT6200-4ESA provides a combination of digital and analog signals at pin IS. These signals are called SENSE. In case the diagnostic is disabled via DEN, pin IS becomes high impedance. In case DEN is activated, the sense current of the channel X is enabled/disabled via associated pins DSEL0 and DSEL1.

Table 8 gives the truth table.

Table 8 Diagnostic truth table

DEN	DSEL1	DSEL0	IS			
0	don't care	don't care	Z	Z	Z	Z
1	0	0	$I_{IS(0)}$	0	0	0
1	0	1	0	$I_{IS(1)}$	0	0
1	1	0	0	0	$I_{IS(2)}$	0
1	1	1	0	0	0	$I_{IS(3)}$

7.1 IS pin

The BTT6200-4ESA provides a sense signal called I_{IS} at pin IS. As long as no “hard” failure mode occurs (short circuit to GND / current limitation / overtemperature / excessive dynamic temperature increase or open load at OFF) a proportional signal to the load current (ratio $k_{ILIS} = I_L / I_{IS}$) is provided. The complete IS pin and diagnostic mechanism is described in Figure 20. The accuracy of the sense current depends on temperature and load current. The sense pin multiplexes the currents $I_{IS(0)}$, $I_{IS(1)}$, $I_{IS(2)}$ and $I_{IS(3)}$ via the pins DSEL0 and DSEL1. Thanks to this multiplexing, the matching between $k_{ILISCHANNEL0}$, $k_{ILISCHANNEL1}$, $k_{ILISCHANNEL2}$ and $k_{ILISCHANNEL3}$ is optimized. Due to the ESD protection, in connection to V_S , it is not recommended to share the IS pin with other devices if these devices are using another battery feed. The consequence is that the unsupplied device would be fed via the IS pin of the supplied device.

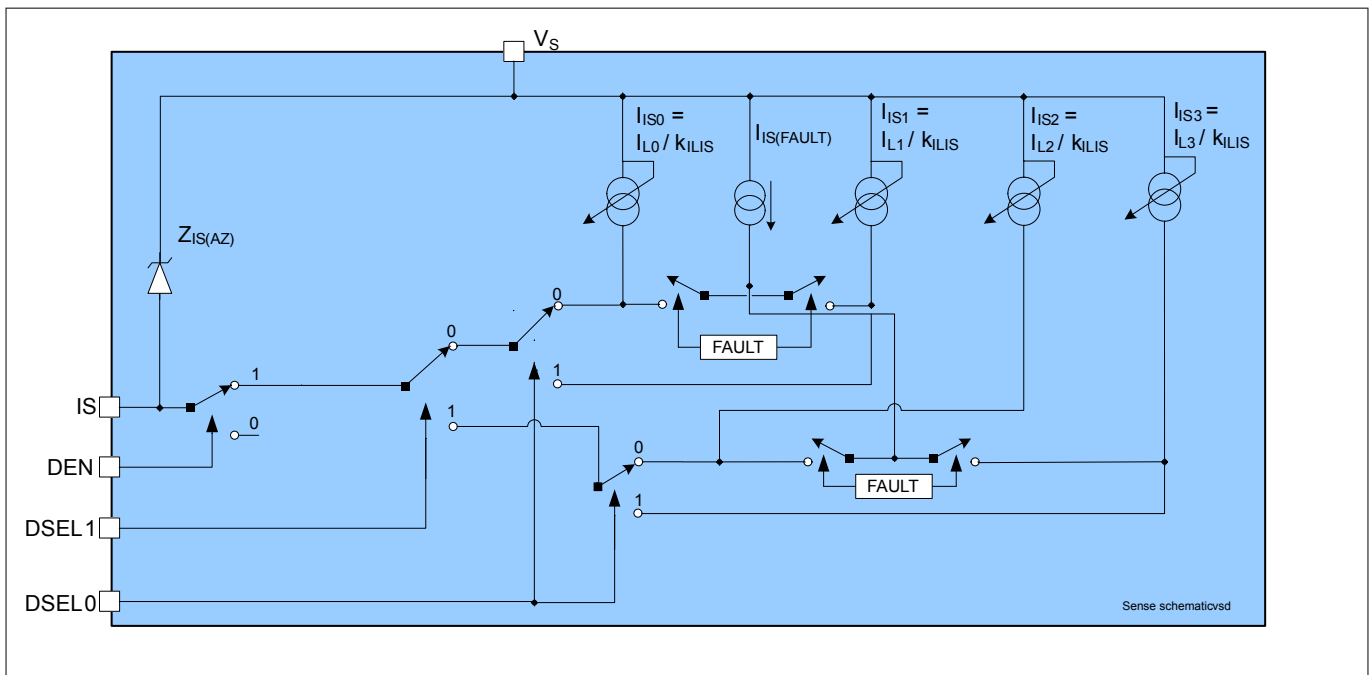

Figure 20 Diagnostic block diagram

Diagnostic functions

7.2 SENSE signal in different operating modes

Table 9 gives a quick reference for the state of the IS pin during device operation.

Table 9 Sense signal, function of operation mode

Operation mode	Input level channel x	DEN ¹⁷⁾	Output level	Diagnostic output		
Normal operation	OFF	H	Z	Z		
Short circuit to GND			~GND	Z		
Overtemperature			Z	Z		
Short circuit to V _S			V _S	I _{IS(FAULT)}		
Open load			< V _{OL(OFF)} ¹⁸⁾	Z		
			> V _{OL(OFF)} ¹⁸⁾	I _{IS(FAULT)}		
Inverse current			~V _{INV}	I _{IS(FAULT)}		
Normal operation			ON		~V _S	I _{IS} = I _L / k _{ILIS}
Current limitation					<V _S	I _{IS(FAULT)}
Short circuit to GND					~GND	I _{IS(FAULT)}
Overtemperature T _{J(SW)} event	Z	I _{IS(FAULT)}				
Short circuit to VS	V _S	I _{IS} < I _L / k _{ILIS}				
Open load	~V _S ¹⁹⁾	I _{IS} < I _{IS(OL)}				
Inverse current	~V _{INV}	I _{IS} < I _{IS(OL)} ²⁰⁾				
Underload	~V _S ²¹⁾	I _{IS(OL)} < I _{IS} < I _L / k _{ILIS}				
Don't care	Don't care	L			Don't care	Z

¹⁷ The table doesn't indicate but it is assumed that the appropriate channel is selected via the DSEL pins.

¹⁸ Stable with additional pull-up resistor.

¹⁹ The output current has to be smaller than I_{L(OL)}.

²⁰ After maximum t_{INV}.

²¹ The output current has to be higher than I_{L(OL)}.

Diagnostic functions

7.3 SENSE signal in nominal current range

Figure 21 shows the current sense as a function of the load current in the power DMOS. Usually, a pull-down resistor R_{IS} is connected to the current sense IS pin. This resistor has to be higher than $560\ \Omega$ to limit the power losses in the sense circuitry. A typical value is $1.2\ \text{k}\Omega$. The blue curve represents the ideal sense current, assuming an ideal k_{ILIS} factor value. The red curves shows the accuracy the device provides across full temperature range at a defined current.

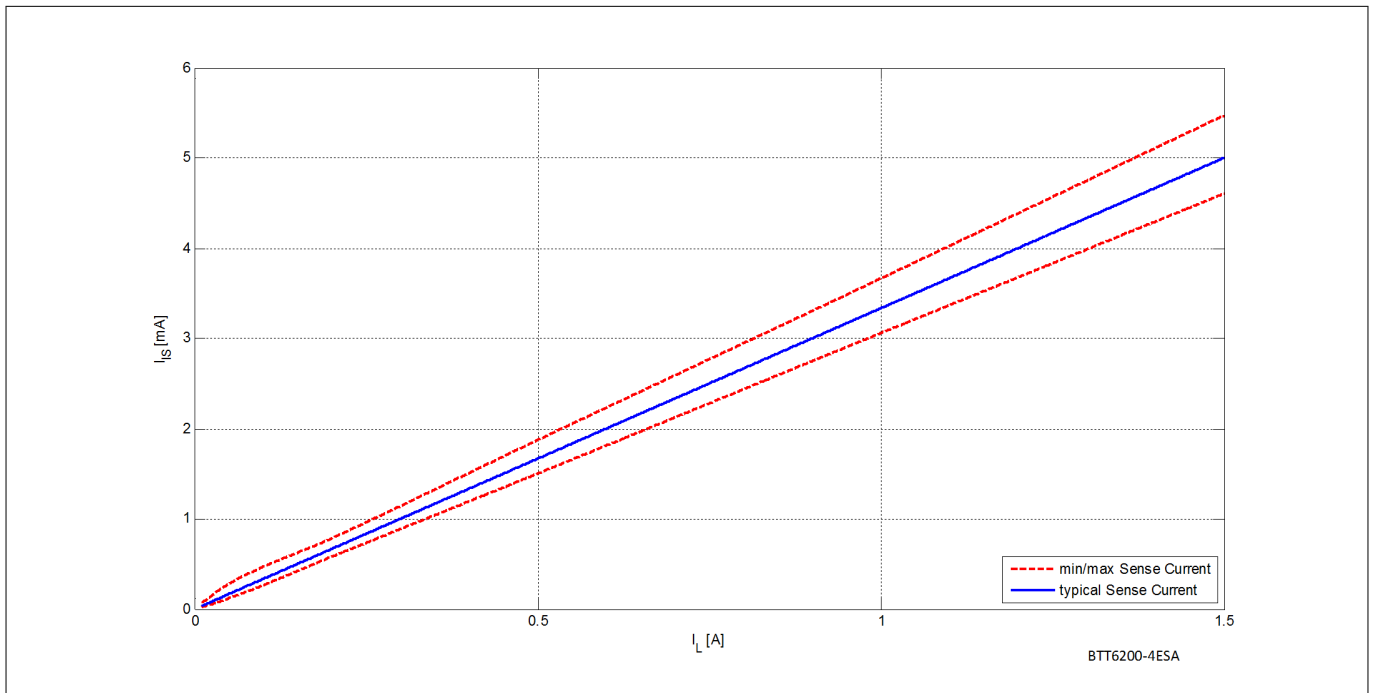

Figure 21 Current sense for nominal load

7.3.1 SENSE signal variation as a function of temperature and load current

In some applications a better accuracy is required at smaller currents. To achieve this accuracy requirement, a calibration on the application is possible. To avoid multiple calibration points at different load and temperature conditions, the BTT6200-4ESA allows limited derating of the k_{ILIS} value, at a given point ($I_{L3}; T_J = +25^\circ\text{C}$). This derating is described by the parameter Δk_{ILIS} . **Figure 22** shows the behavior of the sense current, assuming one calibration point at nominal load at $+25^\circ\text{C}$.

The blue line indicates the ideal k_{ILIS} ratio.

The green lines indicate the derating on the parameter across temperature and voltage, assuming one calibration point at nominal temperature and nominal battery voltage.

The red lines indicate the k_{ILIS} accuracy without calibration.

Diagnostic functions

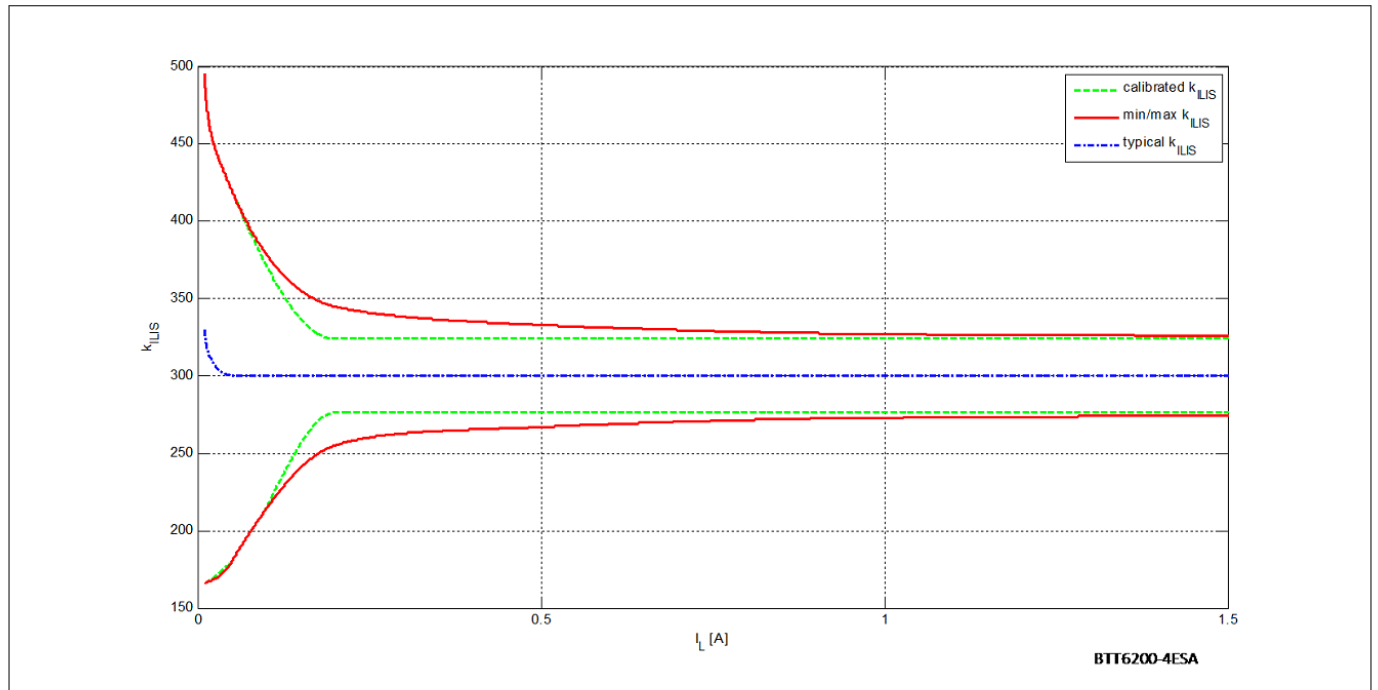

Figure 22 Improved current sense accuracy with one calibration point at 0.2 A

Diagnostic functions

7.3.2 SENSE signal timing

Figure 23 shows the timing during settling and disabling of the SENSE.

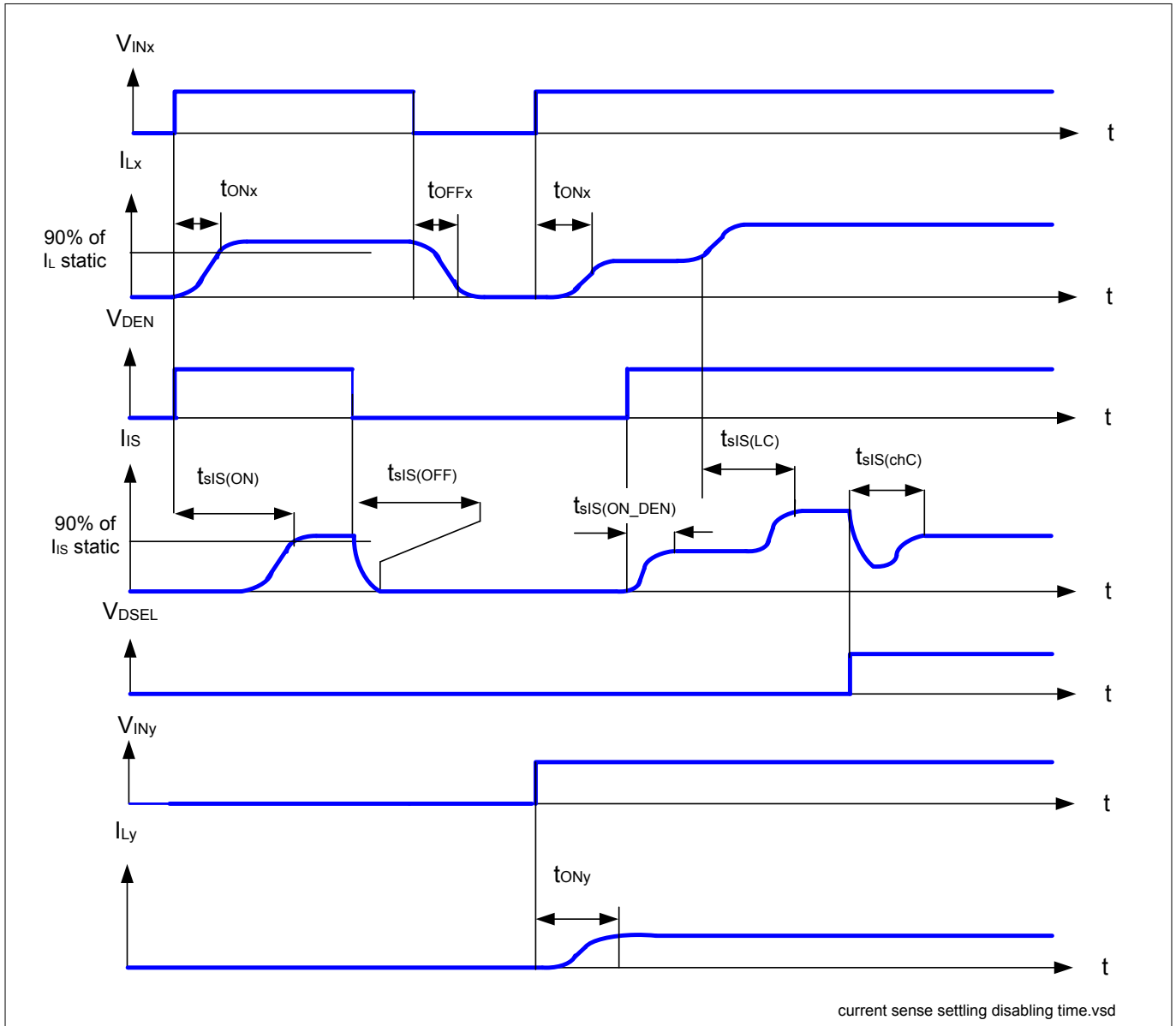

Figure 23 Current sense settling / disabling timing

7.3.3 SENSE signal in open load

7.3.3.1 Open load in ON diagnostic

If the channel is ON, a leakage current can still flow through an open load, for example due to humidity. The parameter $I_{L(OL)}$ gives the threshold of recognition for this leakage current. If the current I_L flowing out the power DMOS is below this value, the device recognizes a failure, if the DEN (and DSEL) is selected. In that case, the SENSE current is below $I_{IS(OL)}$. Otherwise, the minimum SENSE current is given above parameter $I_{IS(OL)}$. Figure 24 shows the SENSE current behavior in this area. The red curve shows a typical product curve. The blue curve shows the ideal current sense.

Diagnostic functions

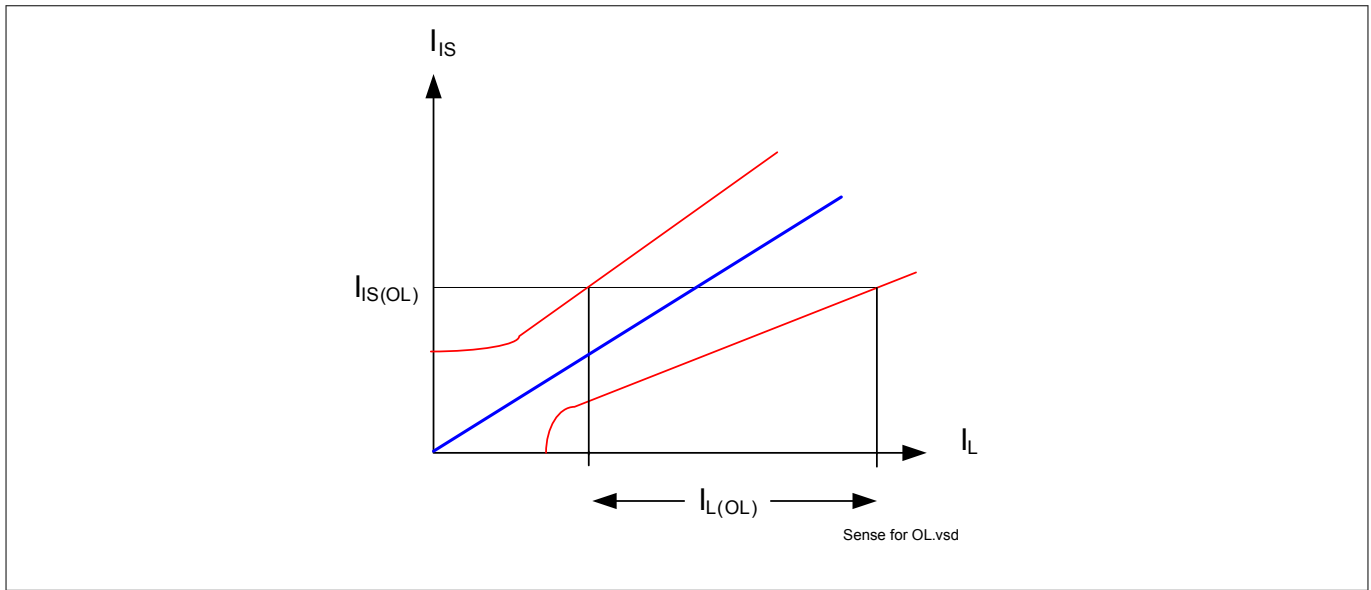

Figure 24 Current sense ratio for low currents

7.3.3.2 Open load in OFF diagnostic

For open load diagnosis in OFF-state, an external output pull-up resistor (R_{OL}) is recommended. For the calculation of pull-up resistor value, the leakage currents and the open load threshold voltage $V_{OL(OFF)}$ have to be taken into account. [Figure 25](#) gives a sketch of the situation. $I_{leakage}$ defines the leakage current in the complete system, including $I_{L(OFF)}$ (see [Chapter 5.5](#)) and external leakages, e.g. due to humidity, corrosion, etc... in the application.

To reduce the stand-by current of the system, an open load resistor switch S_{OL} is recommended. If the channel x is OFF, the output is no longer pulled down by the load and V_{OUT} voltage rises to nearly V_S . This is recognized by the device as an open load. The voltage threshold is given by $V_{OL(OFF)}$. In that case, the SENSE signal is switched to the $I_{IS(FAULT)}$.

An additional RPD resistor can be used to pull V_{OUT} to 0 V. Otherwise, the OUT pin is floating. This resistor can be used as well for short circuit to battery detection, see [Chapter 7.3.4](#)

Diagnostic functions

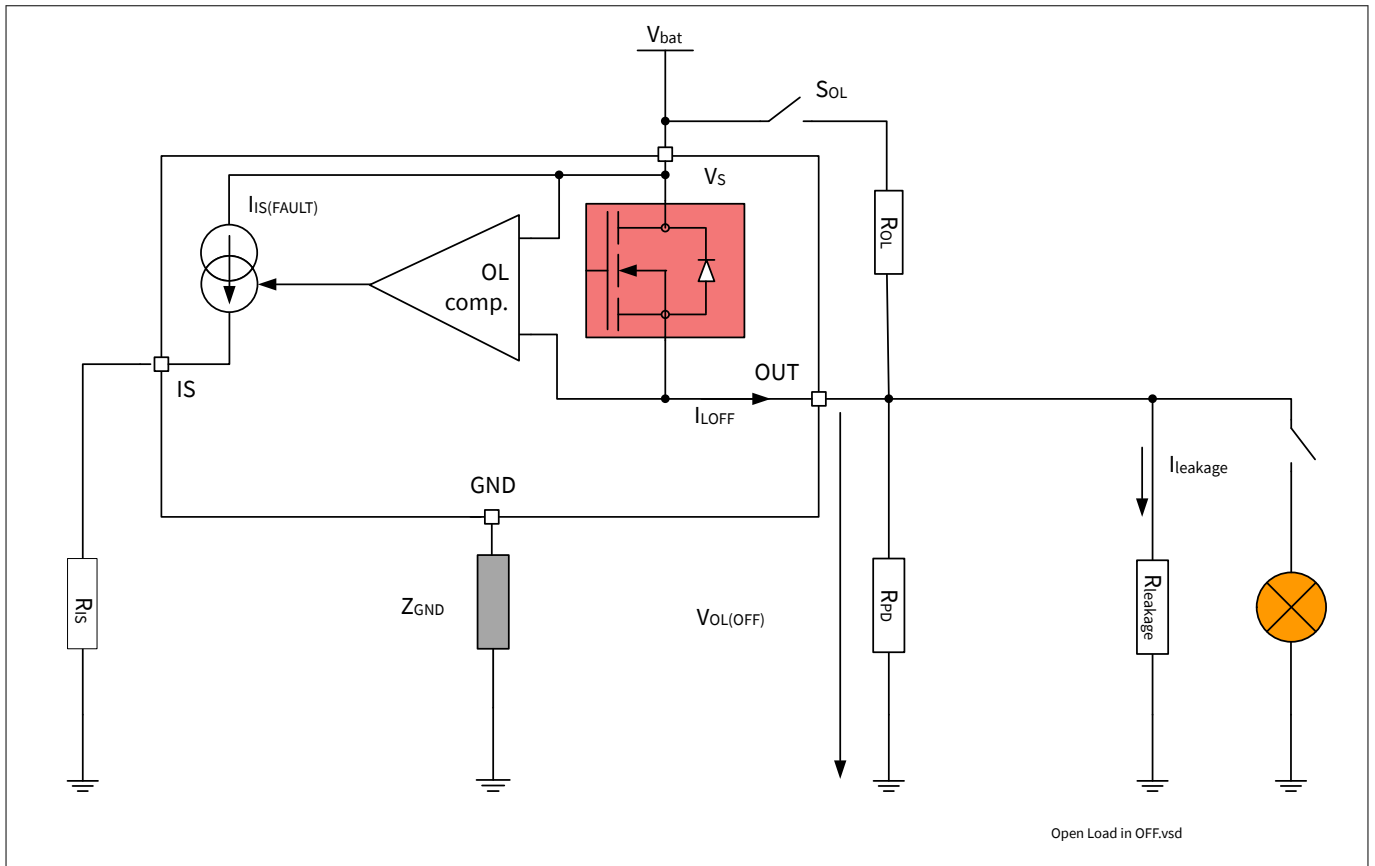

Figure 25 Open load detection in OFF electrical equivalent circuit

7.3.3.3 Open load diagnostic timing

Figure 26 shows the timing during either Open Load in ON or OFF condition when the DEN pin is HIGH. Please note that a delay $t_{sIS(FAULT_OL_OFF)}$ has to be respected after the falling edge of the input, when applying an open load in OFF diagnosis request, otherwise the diagnosis can be wrong.

Diagnostic functions

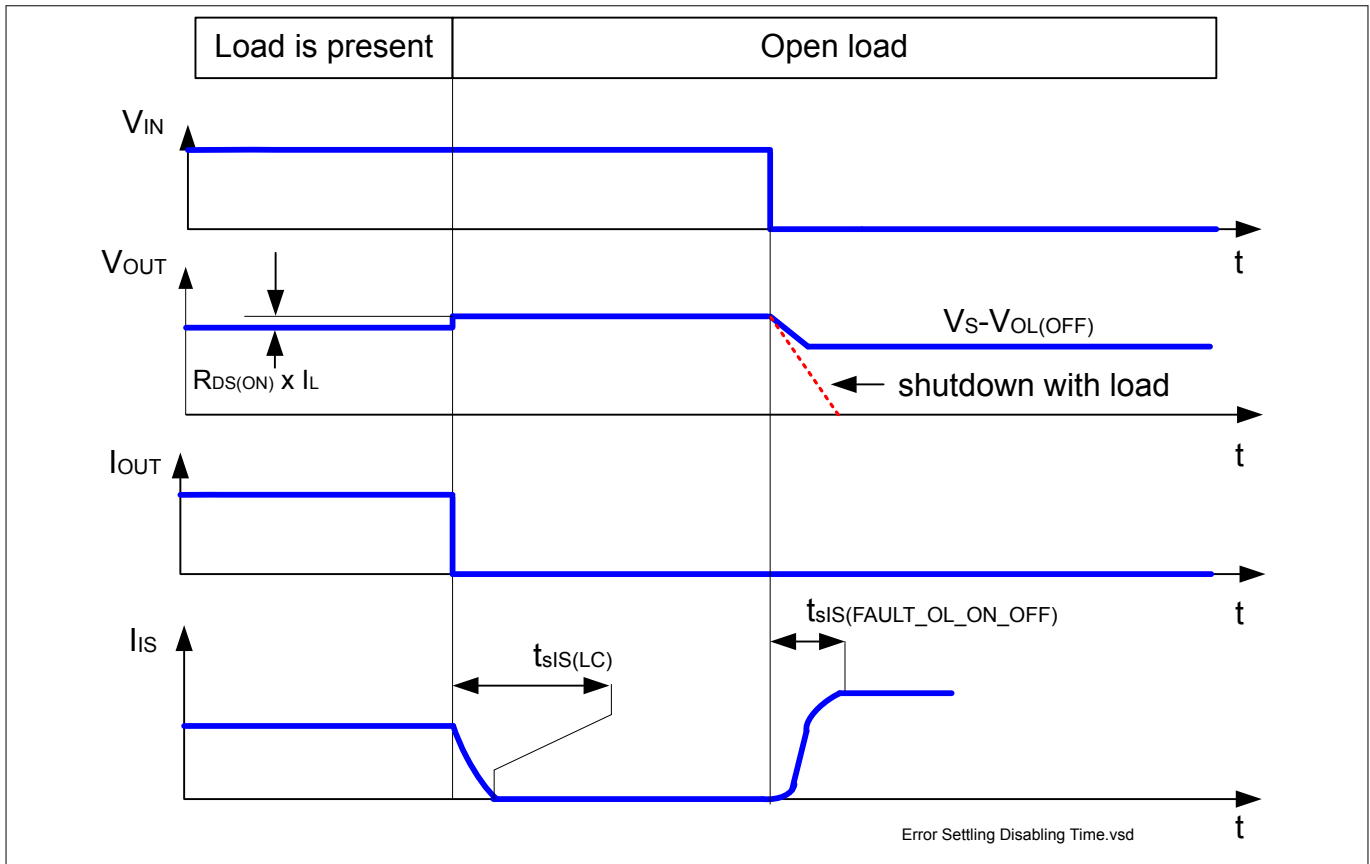

Figure 26 Sense signal in open load timing

7.3.4 SENSE signal in short circuit to VS

In case of a short circuit between the OUTput-pin and the VS pin, all or portion (depending on the short circuit impedance) of the load current will flow through the short circuit. As a result, a lower current compared to the normal operation will flow through the DMOS of the BTT6200-4ESA, which can be recognized at the current sense signal. The open load at OFF detection circuitry can also be used to distinguish a short circuit to VS. In that case, an external resistor to ground R_{SC_VS} is required. [Figure 27](#) gives a sketch of the situation.

Diagnostic functions

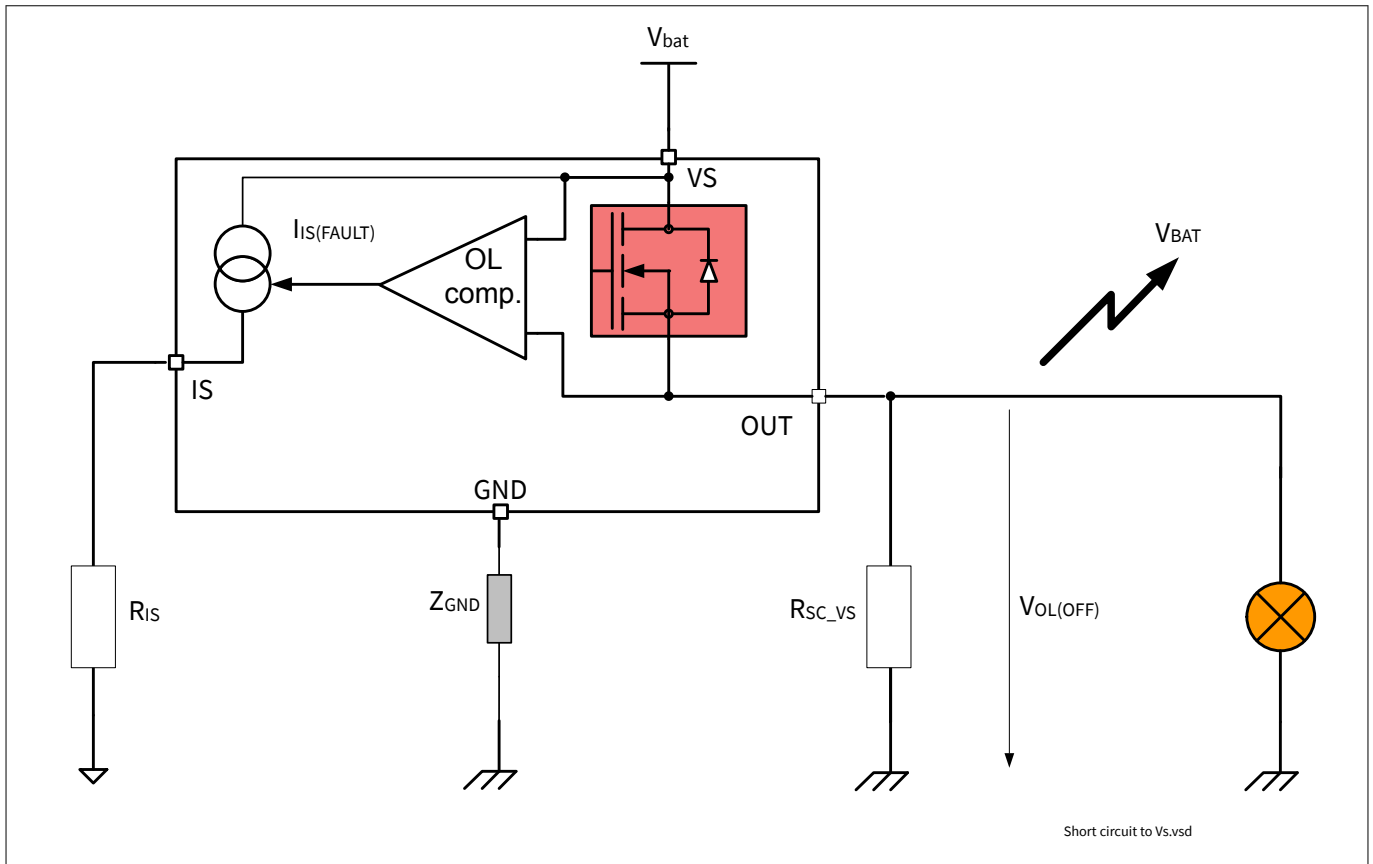

Figure 27 Short circuit to battery detection in OFF electrical equivalent circuit

7.3.5 SENSE signal in case of overload

An overload condition is defined by a current flowing out of the DMOS reaching the current limitation and / or the absolute dynamic temperature swing $T_{J(SW)}$ is reached, and / or the junction temperature reaches the thermal shutdown temperature $T_{J(SC)}$. Please refer to [Chapter 6.5](#) for details.

In that case, the SENSE signal given is by $I_{IS(FAULT)}$ when the diagnostic is selected.

The device has a thermal latch behavior, such that when the overtemperature or the exceed dynamic temperature condition has disappeared, the DMOS is reactivated only when the IN is toggled LOW to HIGH. If the DEN pin is activated, and DSEL pin is selected to the correct channel, the SENSE follows the output stage. If no reset of the latch occurs, the device remains in the latching phase and $I_{IS(FAULT)}$ at the IS pin, even though the DMOS is OFF.

7.3.6 SENSE signal in case of inverse current

In the case of inverse current, the sense signal of the affected channel will indicate open load in OFF state and indicate open load in ON state. The unaffected channels indicate normal behavior as long as the I_{INV} current does not exceed the maximum value specified in [Chapter 5.4](#).

Diagnostic functions

7.4 Electrical characteristics diagnostic function

Table 10 Electrical characteristics: Diagnostics

$V_S = 8\text{ V to }36\text{ V}$, $T_J = -40^\circ\text{C to }150^\circ\text{C}$ (unless otherwise specified).

Typical values are given at $V_S = 28\text{ V}$, $T_J = 25^\circ\text{C}$

Parameter	Symbol	Values			Unit	Note or Test Condition	Number
		Min.	Typ.	Max.			
Load condition threshold for diagnostic							
Open load detection threshold in OFF state	$V_S - V_{OL(OFF)}$	4	–	6	V	²²⁾ $V_{IN} = 0\text{ V}$ $V_{DEN} = 4.5\text{ V}$ See Figure 26	P_7.5.1
Open load detection threshold in ON state	$I_{L(OL)}$	5	–	15	mA	$V_{IN} = V_{DEN} = 4.5\text{ V}$ $I_{IS(OL)} = 33\text{ }\mu\text{A}$ See Figure 24 See Chapter 9.4	P_7.5.2
Sense pin							
IS pin leakage current when sense is disabled	$I_{IS(DIS)}$	–	0.02	1	μA	²²⁾ $V_{IN} = 4.5\text{ V}$ $V_{DEN} = 0\text{ V}$ $I_L = I_{L4} = \text{A}$	P_7.5.4
Sense signal saturation voltage	$V_S - V_{IS}$ (RANGE)	1	–	3.5	V	$V_{IN} = 0\text{ V}$ $V_{OUT} = V_S > 10\text{ V}$ $V_{DEN} = 4.5\text{ V}$ $I_{IS} = 6\text{ mA}$ See Chapter 9.4	P_7.5.6
Sense signal maximum current in fault condition	$I_{IS(FAULT)}$	6	15	35	mA	$V_{IS} = V_{IN} = V_{DSEL} = 0\text{ V}$ $V_{OUT} = V_S > 10\text{ V}$ $V_{DEN} = 4.5\text{ V}$ See Figure 20 See Chapter 9.4	P_7.5.7
Sense pin maximum voltage VS to IS	$V_{IS(AZ)}$	65	70	75	V	$I_{IS} = 5\text{ mA}$ See Figure 20	P_7.5.3

Current sense ratio signal in the nominal area, stable load current condition

²²⁾ DSEL pin select channel 0 only.

Diagnostic functions

Table 10 Electrical characteristics: Diagnostics (continued)

$V_S = 8\text{ V to }36\text{ V}$, $T_J = -40^\circ\text{C to }150^\circ\text{C}$ (unless otherwise specified).

Typical values are given at $V_S = 28\text{ V}$, $T_J = 25^\circ\text{C}$

Parameter	Symbol	Values			Unit	Note or Test Condition	Number
		Min.	Typ.	Max.			
Current sense ratio $I_{L0} = 10\text{ mA}$	k_{ILIS0}	-50%	330	+50%		$V_{IN} = 4.5\text{ V}$ $V_{DEN} = 4.5\text{ V}$	P_7.5.8
Current sense ratio $I_{L1} = 0.05\text{ A}$	k_{ILIS1}	-40%	300	+40%		See Figure 21 $T_J = -40^\circ\text{C}; 150^\circ\text{C}$	P_7.5.9
Current sense ratio $I_{L2} = 0.2\text{ A}$	k_{ILIS2}	-15%	300	+15%			P_7.5.10
Current sense ratio $I_{L3} = 0.5\text{ A}$	k_{ILIS3}	-11%	300	+11%			P_7.5.11
Current sense ratio $I_{L4} = 1\text{ A}$	k_{ILIS4}	-9%	300	+9%			P_7.5.12
k_{ILIS} derating with current and temperature	Δk_{ILIS}	-8	0	+8	%	²³⁾ k_{ILIS3} versus k_{ILIS2} See Figure 22	P_7.5.17

Diagnostic timing in normal condition

Current sense settling time to k_{ILIS} function stable after positive input slope on both INput and DEN	$t_{SIS(ON)}$	-	-	150	μs	²³⁾ $V_{DEN} = V_{IN} = 0$ to 4.5 V $V_S = 28\text{ V}$ $R_{IS} = 1.2\text{ k}\Omega$ $C_{SENSE} < 100\text{ pF}$ $I_L = I_{L3} = 0.5\text{ A}$ See Figure 23	P_7.5.18
Current sense settling time with load current stable and transition of the DEN	$t_{SIS(ON_DEN)}$	-	-	10	μs	²²⁾ $V_{DEN} = 0$ to 4.5 V $R_{IS} = 1.2\text{ k}\Omega$ $C_{SENSE} < 100\text{ pF}$ $I_L = I_{L3} = 0.5\text{ A}$ See Figure 23	P_7.5.19
Current sense settling time to I_{IS} stable after positive input slope on current load	$t_{SIS(LC)}$	-	-	15	μs	²²⁾ $V_{DEN} = 4.5\text{ V}$ $R_{IS} = 1.2\text{ k}\Omega$ $C_{SENSE} < 100\text{ pF}$ $I_L = I_{L2} = 0.2\text{ A}$ to $I_L = I_{L3} = 0.5\text{ A}$ See Figure 23	P_7.5.20

Diagnostic timing in open load condition

²³ Not subject to production test, specified by design. Current sense settling time to

²² DSEL pin select channel 0 only.

Diagnostic functions

Table 10 Electrical characteristics: Diagnostics (continued)

$V_S = 8\text{ V to }36\text{ V}$, $T_J = -40^\circ\text{C to }150^\circ\text{C}$ (unless otherwise specified).

Typical values are given at $V_S = 28\text{ V}$, $T_J = 25^\circ\text{C}$

Parameter	Symbol	Values			Unit	Note or Test Condition	Number
		Min.	Typ.	Max.			
Current sense settling time to I_{IS} stable for open load detection in OFF state	$t_{sIS(FAULT_OL_OFF)}$	–	–	50	μs	²²⁾ $V_{DEN} = 0\text{ to }4.5\text{ V}$ $R_{IS} = 1.2\text{ k}\Omega$ $C_{SENSE} < 100\text{ pF}$ $V_{OUT} = V_S = 28\text{ V}$	P_7.5.22
Current sense settling time to I_{IS} stable for open load detection in ON-OFF transition	$t_{sIS(FAULT_OL_ON_OFF)}$	–	150	–	μs	²³⁾ $V_{IN} = 4.5\text{ to }0\text{ V}$ $V_{DEN} = 4.5\text{ V}$ $R_{IS} = 1.2\text{ k}\Omega$ $C_{SENSE} < 100\text{ pF}$ $V_{OUT} = V_S = 28\text{ V}$ See Figure 26	P_7.5.23

Diagnostic timing in overload condition

Current sense settling time to I_{IS} stable for overload detection	$t_{sIS(FAULT)}$	–	–	150	μs	²⁴⁾²⁵⁾²⁶⁾ $V_{IN} = V_{DEN} = 0$ to 4.5 V $R_{IS} = 1.2\text{ k}\Omega$ $C_{SENSE} < 100\text{ pF}$ $V_{DS} = 5\text{ V}$ See Figure 19	P_7.5.24
Current sense over current blanking time	$t_{sIS(OC_blank)}$	–	350	–	μs	$V_{IN} = V_{DEN} = 4.5\text{ V}$ $R_{IS} = 1.2\text{ k}\Omega$ $C_{SENSE} < 100\text{ pF}$ $V_{DS} = 5\text{ V to }0\text{ V}$ See Figure 19	P_7.5.32
Diagnostic disable time DEN transition to $I_{IS} < 50\% I_L / k_{ILIS}$	$t_{sIS(OFF)}$	–	–	20	μs	$V_{IN} = 4.5\text{ V}$ $V_{DEN} = 4.5\text{ V to }0\text{ V}$ $R_{IS} = 1.2\text{ k}\Omega$ $C_{SENSE} < 100\text{ pF}$ $I_L = I_{L3} = 0.5\text{ A}$ See Figure 23	P_7.5.25

²² DSEL pin select channel 0 only.

²³ Not subject to production test, specified by design. Current sense settling time to

²⁴ DSEL pin select channel 0 only.

²⁵ Test at $T_J = -40^\circ\text{C}$ only.

²⁶ Functional Test only.

Diagnostic functions

Table 10 Electrical characteristics: Diagnostics (continued)

$V_S = 8\text{ V to }36\text{ V}$, $T_J = -40^\circ\text{C to }150^\circ\text{C}$ (unless otherwise specified).

Typical values are given at $V_S = 28\text{ V}$, $T_J = 25^\circ\text{C}$

Parameter	Symbol	Values			Unit	Note or Test Condition	Number
		Min.	Typ.	Max.			
Current sense settling time from one channel to another	$t_{SIS(ChC)}$	–	–	20	μs	$V_{IN0} = V_{IN1} = 4.5\text{ V}$ $V_{DEN} = 4.5\text{ V}$ $V_{DSEL} = 0\text{ to }4.5\text{ V}$ $R_{IS} = 1.2\text{ k}\Omega$ $C_{SENSE} < 100\text{ pF}$ $I_{L(OUT0)} = I_{L3} = 0.5\text{ A}$ $I_{L(OUT1)} = I_{L2} = 0.2\text{ A}$ See Figure 23	P_7.5.26

Input pins

8 Input pins

8.1 Input circuitry

The input circuitry is compatible with 3.3 V and 5 V microcontrollers. The concept of the input pin is to react to voltage thresholds. An implemented Schmitt trigger avoids any undefined state if the voltage on the input pin is slowly increasing or decreasing. The output is either OFF or ON but cannot be in a linear or undefined state. The input circuitry is compatible with PWM applications. [Figure 28](#) shows the electrical equivalent input circuitry. In case the pin is not needed, it must be left opened, or must be connected to device ground (and not module ground) via a 10 kΩ input resistor.

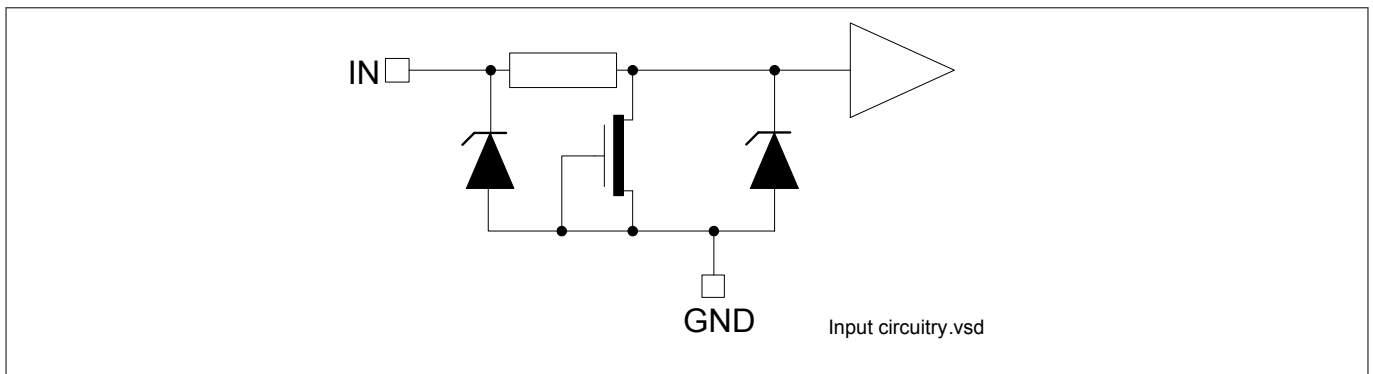

Figure 28 Input pin circuitry

8.2 DEN / DSEL0, 1 pin

The DEN / DSEL0, 1 pins enable and disable the diagnostic functionality of the device. The pins have the same structure as the INput pins, please refer to [Figure 28](#).

8.3 Input pin voltage

The IN, DSEL and DEN use a comparator with hysteresis. The switching ON / OFF takes place in a defined region, set by the thresholds $V_{IN(L)}$ Max. and $V_{IN(H)}$ Min. The exact value where the ON and OFF take place are unknown and depends on the process, as well as the temperature. To avoid cross talk and parasitic turn ON and OFF, a hysteresis is implemented. This ensures a certain immunity to noise.

8.4 Electrical characteristics

Table 11 Electrical characteristics: Input pins

$V_S = 8\text{ V to }36\text{ V}$, $T_J = -40^\circ\text{C to }150^\circ\text{C}$ (unless otherwise specified).

Typical values are given at $V_S = 28\text{V}$, $T_J = 25^\circ\text{C}$

Parameter	Symbol	Values			Unit	Note or Test Condition	Number
		Min.	Typ.	Max.			
INput pins characteristics							
Low level input voltage range	$V_{IN(L)}$	-0.3	-	0.8	V	See Chapter 9.5	P_8.4.1
High level input voltage range	$V_{IN(H)}$	2	-	6	V	See Chapter 9.5	P_8.4.2

Input pins

Table 11 Electrical characteristics: Input pins (continued)

$V_S = 8\text{ V to }36\text{ V}$, $T_J = -40^\circ\text{C to }150^\circ\text{C}$ (unless otherwise specified).

Typical values are given at $V_S = 28\text{ V}$, $T_J = 25^\circ\text{C}$

Parameter	Symbol	Values			Unit	Note or Test Condition	Number
		Min.	Typ.	Max.			
Input voltage hysteresis	$V_{IN(HYS)}$	–	250	–	mV	²⁷⁾ See Chapter 9.5	P_8.4.3
Low level input current	$I_{IN(L)}$	1	10	25	μA	$V_{IN} = 0.8\text{ V}$	P_8.4.4
High level input current	$I_{IN(H)}$	2	10	25	μA	$V_{IN} = 5.5\text{ V}$ See Chapter 9.5	P_8.4.5

DEN Pin

Low level input voltage range	$V_{DEN(L)}$	-0.3	–	0.8	V	–	P_8.4.6
High level input voltage range	$V_{DEN(H)}$	2	–	6	V	–	P_8.4.7
Input voltage hysteresis	$V_{DEN(HYS)}$	–	250	–	mV	²⁷⁾	P_8.4.8
Low level input current	$I_{DEN(L)}$	1	10	25	μA	$V_{DEN} = 0.8\text{ V}$	P_8.4.9
High level input current	$I_{DEN(H)}$	2	10	25	μA	$V_{DEN} = 5.5\text{ V}$	P_8.4.10

DSEL Pins

Low level input voltage range	$V_{DSEL(L)}$	-0.3	–	0.8	V	–	P_8.4.11
High level input voltage range	$V_{DSEL(H)}$	2	–	6	V	–	P_8.4.12
Input voltage hysteresis	$V_{DSEL(HYS)}$	–	250	–	mV	²⁷⁾	P_8.4.13
Low level input current	$I_{DSEL(L)}$	1	10	25	μA	$V_{DSEL} = 0.8\text{ V}$	P_8.4.14
High level input current	$I_{DSEL(H)}$	2	10	25	μA	$V_{DSEL} = 5.5\text{ V}$	P_8.4.15

²⁷⁾ Not subject to production test, specified by design.

Characterization results

9 Characterization results

The characterization has been performed on 3 lots, with 3 devices each. Characterization has been performed at 8 V, 28 V and 36 V overtemperature range.

9.1 General product characteristics

P_4.2.3

Minimum functional supply voltage $V_{S(OP_MIN)} = f(T_J)$

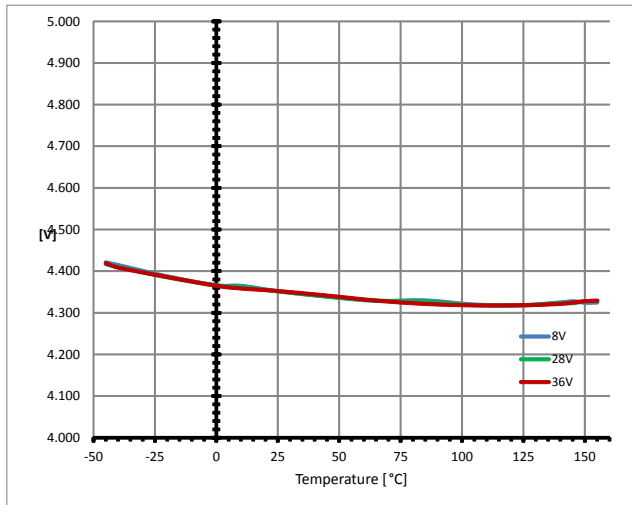

P_4.2.4

Undervoltage threshold $V_{S(UV)} = f(T_J)$

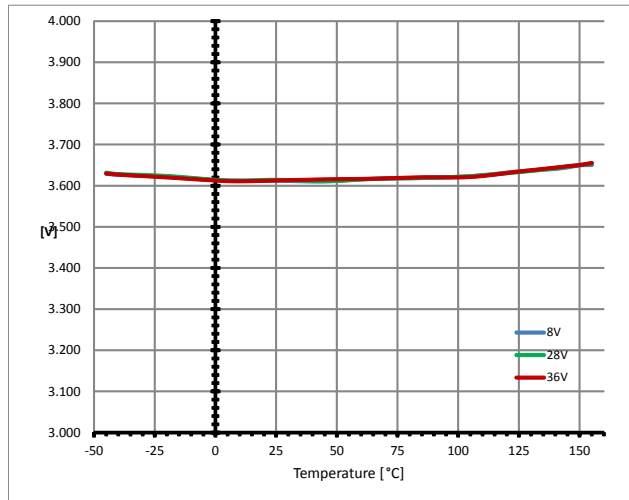

P_4.2.6

Current consumption for whole device with load - all channels active $I_{GND_2} = f(T_J; V_S)$

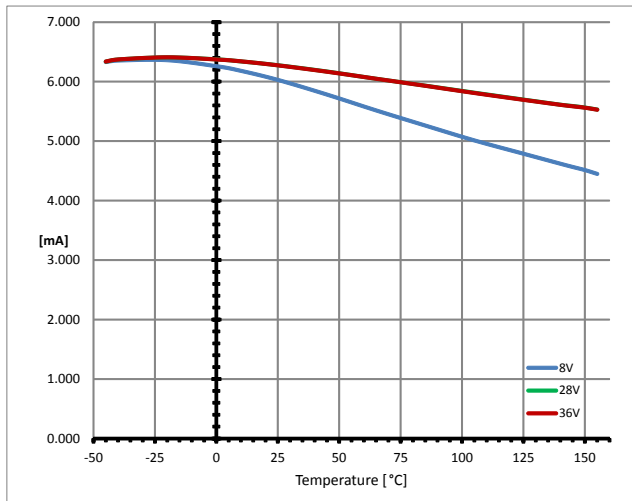

P_4.2.7, P_4.2.10

Standby current for whole device with load $I_{S(OFF)} = f(T_J; V_S)$

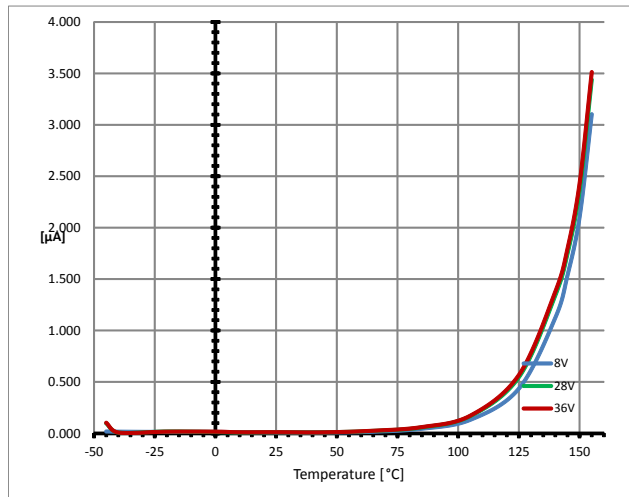

Characterization results

9.2 Power stage

P_5.5.4

Output voltage drop limitation at low load current:
 $V_{DS(NL)} = f(T_J)$ and $V_{DS(NL)} = f(V_S)$

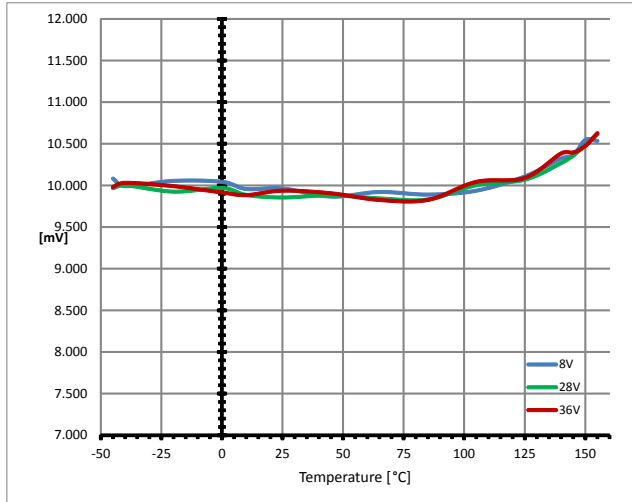

P_5.5.5

Drain to source clamp voltage $V_{DS(AZ)} = f(T_J)$

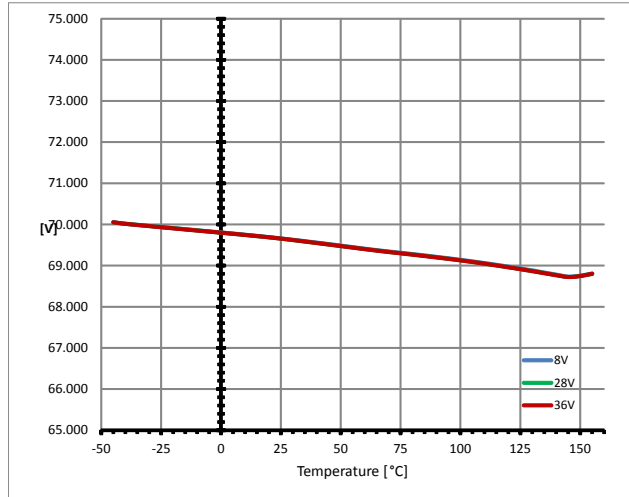

P_5.5.11

Slew rate at turn ON $dV / dt_{ON} = f(T_J; V_S) = R_L = 47 \Omega$

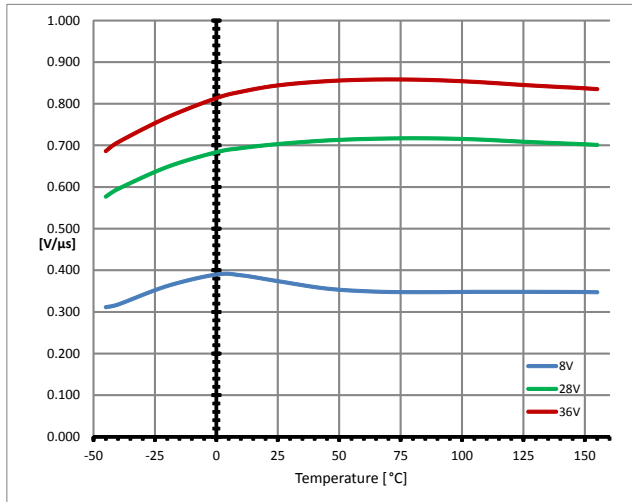

P_5.5.12

Slew rate at turn OFF $dV / dt_{OFF} = f(T_J; V_S) = R_L = 47 \Omega$

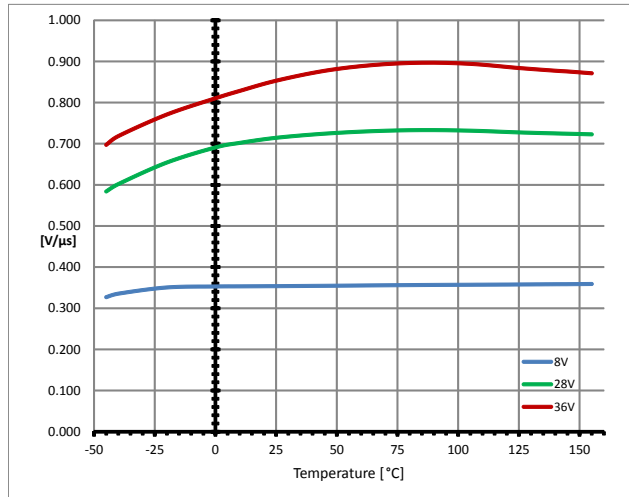

Characterization results

P_5.5.14

Turn ON $t_{ON} = f(T_J; V_S) = R_L = 47 \Omega$

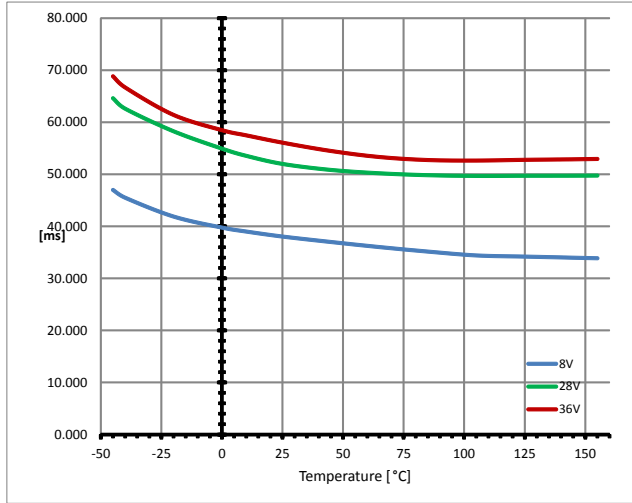

P_5.5.15

Turn OFF $t_{OFF} = f(T_J; V_S) = R_L = 47 \Omega$

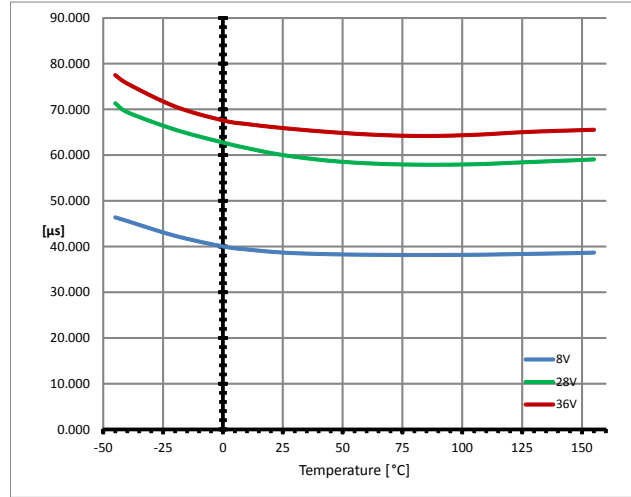

P_5.5.19

Switch ON energy $E_{ON} = f(T_J; V_S) = R_L = 47 \Omega$

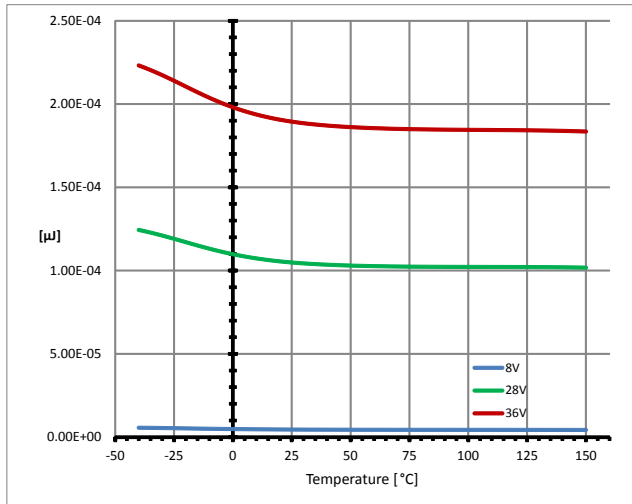

P_5.5.20

Switch OFF energy $E_{OFF} = f(T_J; V_S) = R_L = 47 \Omega$

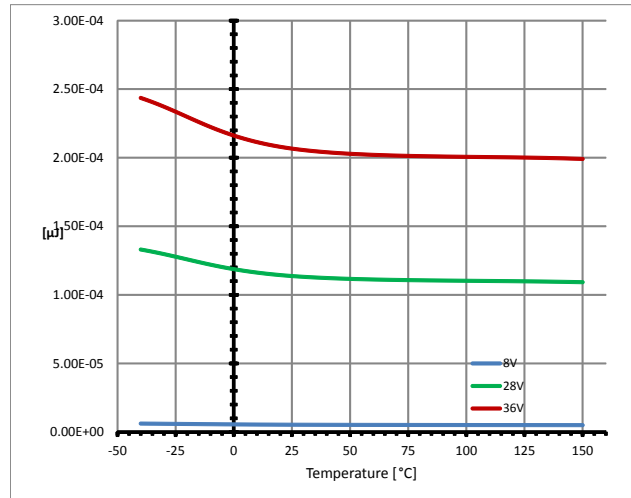

Characterization results

9.3 Protection functions

P_6.6.4

Overload condition in the low voltage area $I_{L5(SC)} = f(T_J; V_S)$

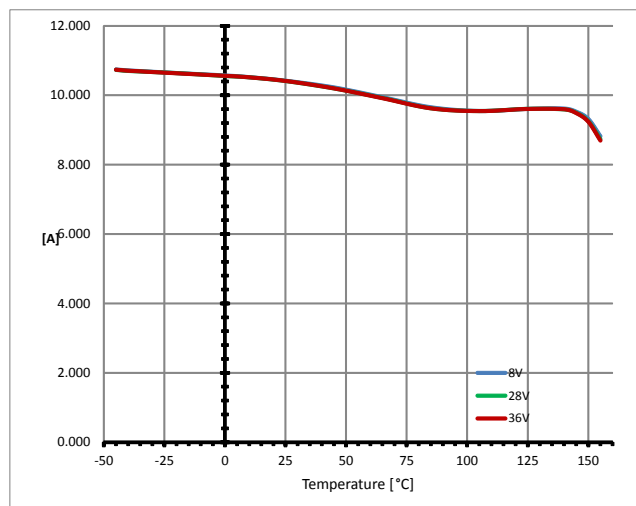

Characterization results

9.4 Diagnostic mechanism

Current sense at no load $I_{IS} = f(T_J; V_S) / I_L = 0$

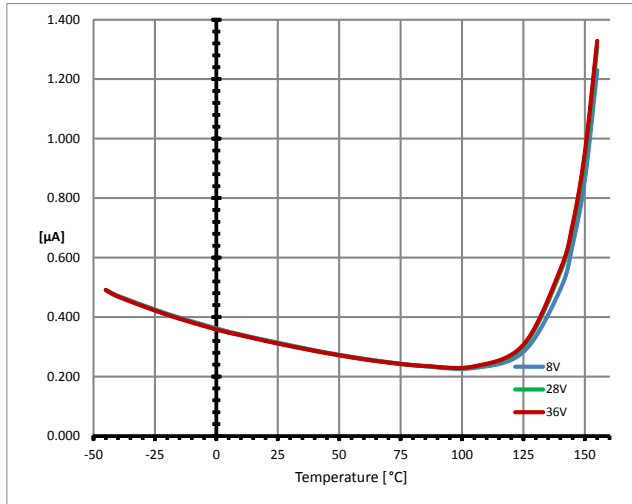

P_7.5.2

Open load detection ON state threshold $I_{L(OL)} = f(T_J)$

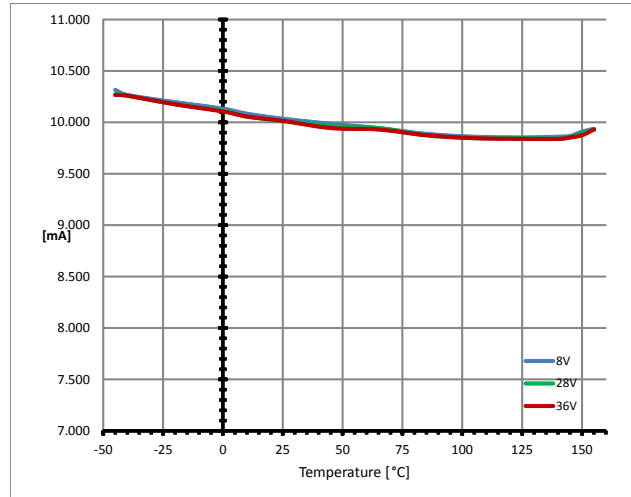

P_7.5.3

Sense signal at maximum voltage $V_{IS(AZ)} = f(T_J; V_S)$

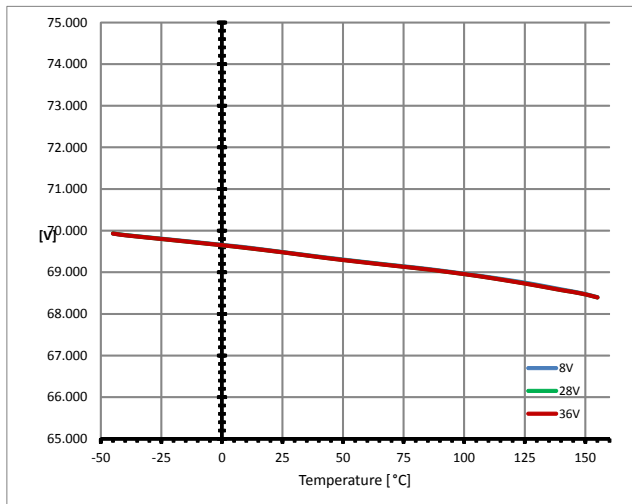

P_7.5.7

Sense signal maximum current in fault condition $I_{IS(FAULT)} = f(T_J; V_S)$

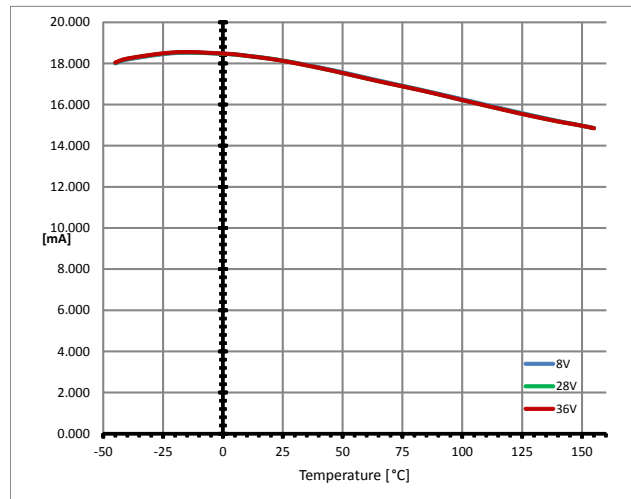

Characterization results

9.5 Input pins

P_8.4.1

Input voltage threshold $V_{IN(L)} = f(T_J; V_S)$

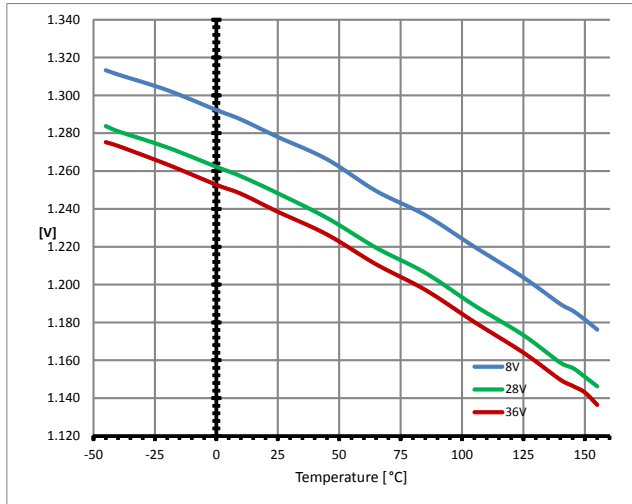

P_8.4.2

Input voltage threshold $V_{IN(H)} = f(T_J; V_S)$

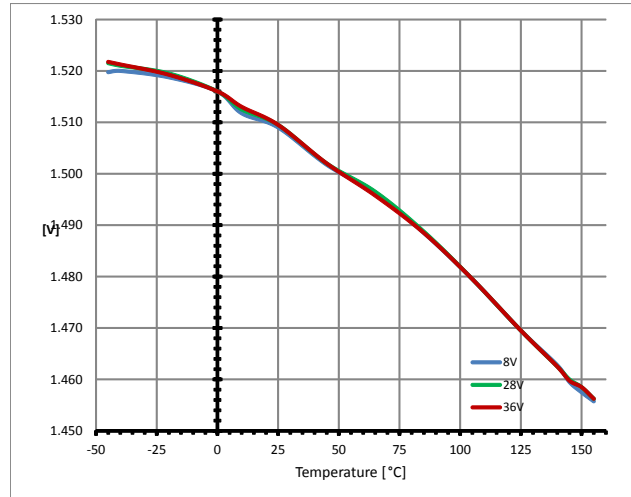

P_8.4.3

Input voltage hysteresis $V_{IN(HYS)} = f(T_J; V_S)$

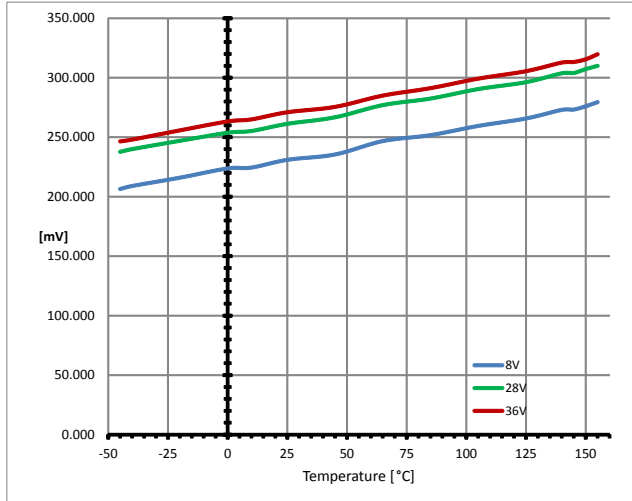

P_8.4.5

Input current high level $I_{IN(H)} = f(T_J; V_S)$

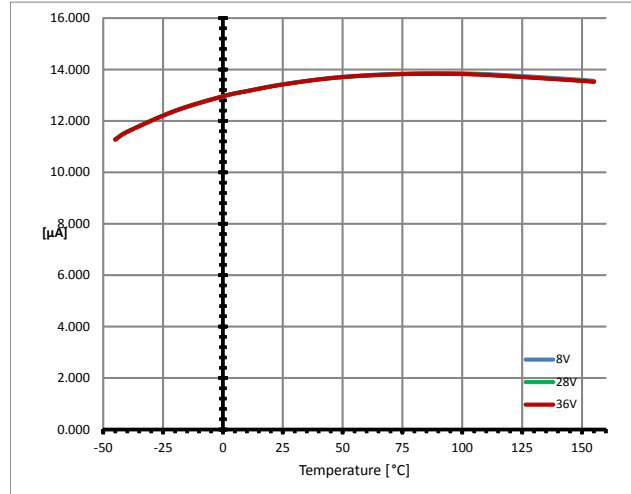

Application information

10 Application information

Note: The following information is given as a hint for the implementation of the device only and shall not be regarded as a description or warranty of a certain functionality, condition or quality of the device.

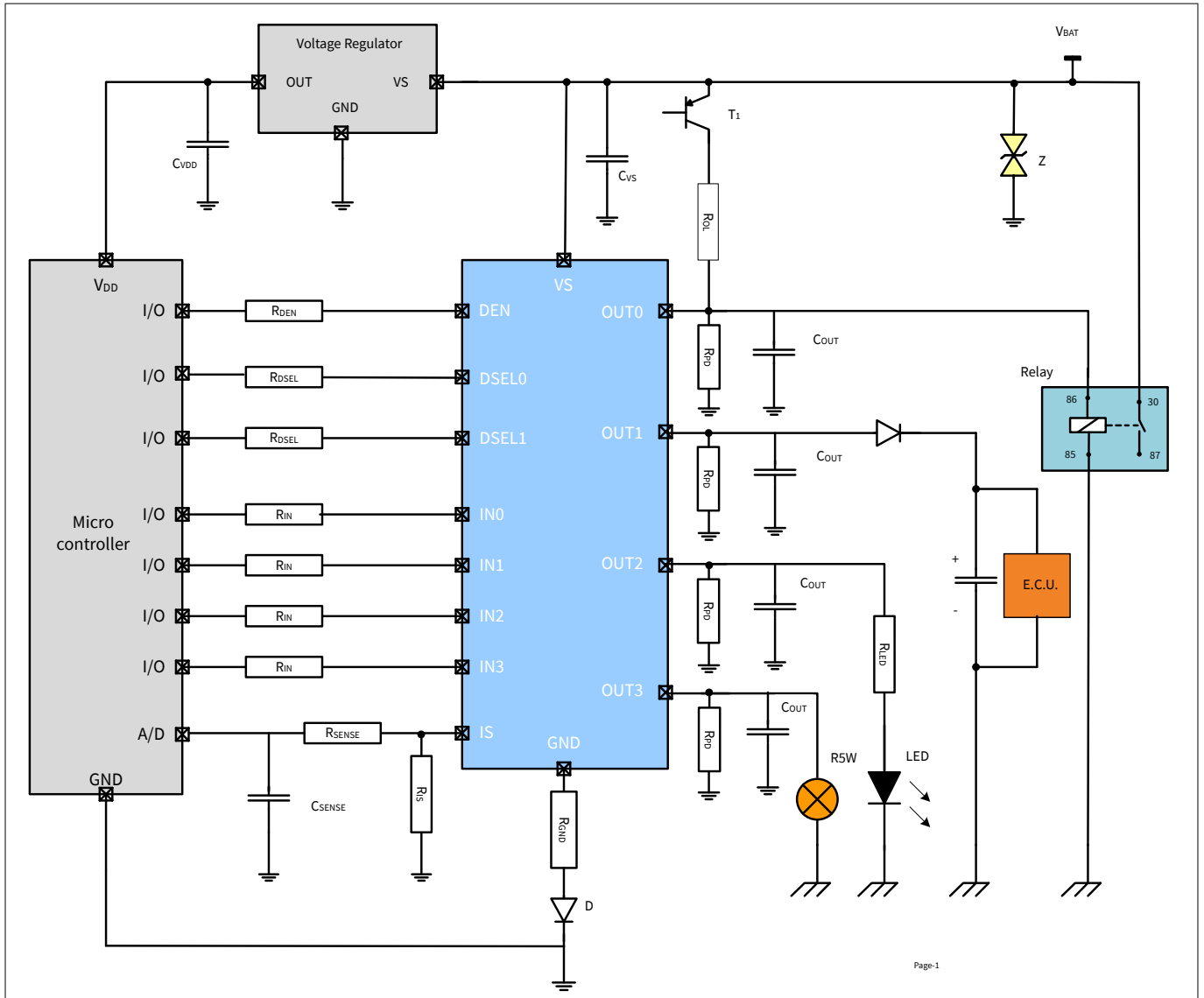

Figure 29 Application diagram with BTT6200-4ESA

Note: This is a very simplified example of an application circuit. The function must be verified in the real application.

Table 12 Bill of material

Reference	Value	Purpose
R_{IN}	10 kΩ	Protection of the microcontroller during overvoltage, reverse polarity Guarantee BTT6200-4ESA channels OFF during loss of ground
R_{DSEL}	10 kΩ	Protection of the microcontroller during overvoltage, reverse polarity
R_{DEN}	10 kΩ	Protection of the microcontroller during overvoltage, reverse polarity

Application information

Table 12 Bill of material (continued)

Reference	Value	Purpose
R_{PD}	47 k Ω	Polarization of the output for short circuit to VS detection. Improve BTT6200-4ESA immunity to electromagnetic noise
R_{OL}	1.5 k Ω	Polarization of the output during open load in OFF detection
R_{IS}	1.2 k Ω	Sense resistor
R_{SENSE}	10 k Ω	Overvoltage, reverse polarity, loss of ground. Value to be tuned with microcontroller specification.
C_{SENSE}	100 pF	Sense signal filtering
C_{OUT}	10 nF	Protection of the device during ESD and BCI
R_{LED}	680 Ω	Overvoltage protection of the LED. Value to be tuned with LED specification
R_{GND}	27 Ω	Protection of the BTT6200-4ESA during overvoltage
D	BAS21	Protection of the BTT6200-4ESA during reverse polarity
Z	58 V Zener diode	Protection of the device during overvoltage
CVS	100 nF	Filtering of voltage spikes at the battery line
$T1$	Dual NPN/PNP	Switch the battery voltage for open load in OFF diagnostic

10.1 Further application information

- Please contact us to get the pin FMEA
- Existing App. Notes
- For further information you may visit www.infineon.com

Package outlines

11 Package outlines

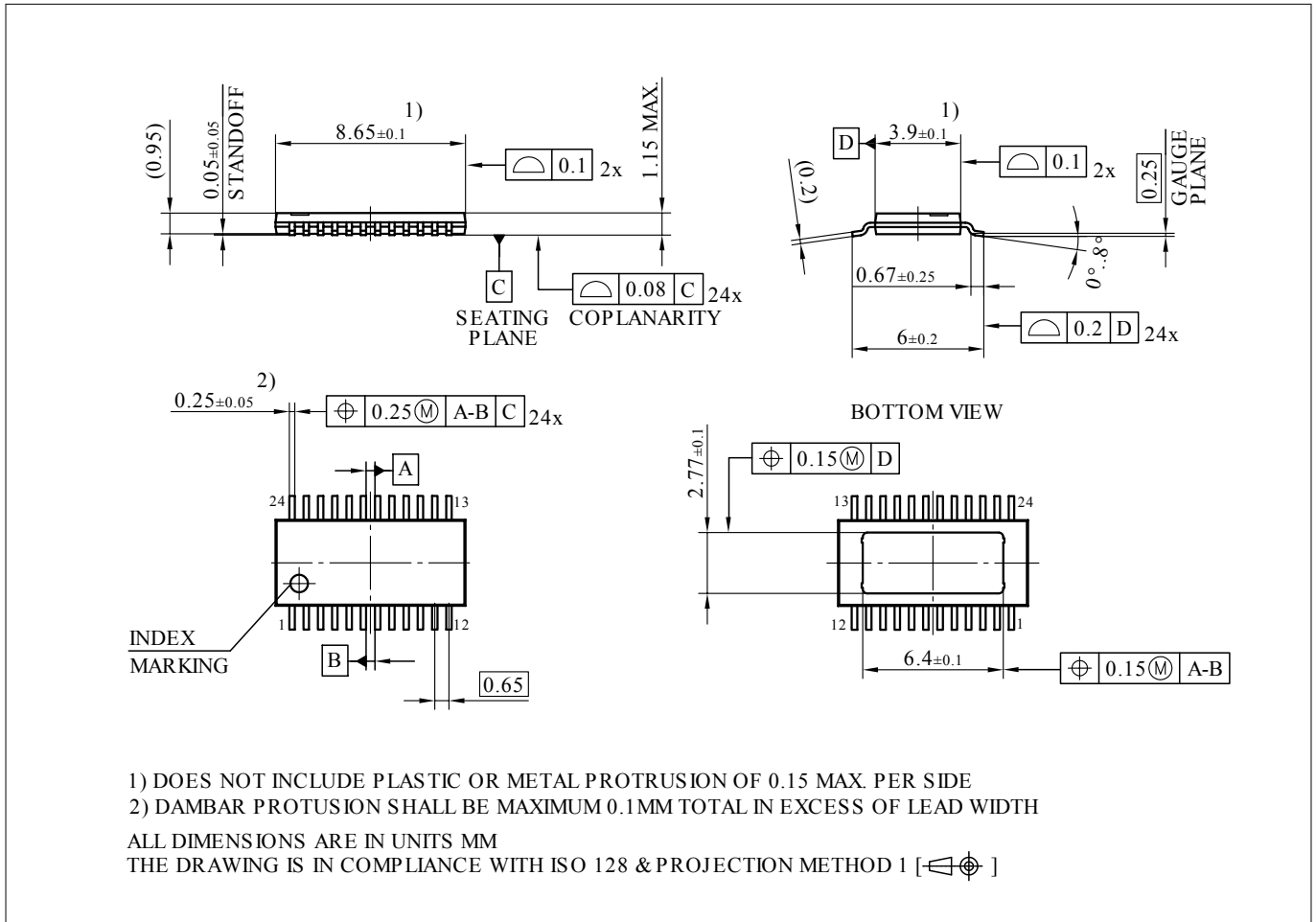

Figure 30 PG-TSDSO-24 (Plastic dual small outline package)(RoHS-compliant)

Green product (RoHS compliant)

To meet the world-wide customer requirements for environmentally friendly products and to be compliant with government regulations the device is available as a green product. Green products are RoHS-Compliant (i.e Pb-free finish on leads and suitable for Pb-free soldering according to IPC/JEDEC J-STD-020).

Legal disclaimer for short-circuit capability

Infineon disclaims any warranties and liabilities, whether expressed or implied, for any short-circuit failures below the threshold limit.

Revision history

Revision history

Document version	Date of release	Description of changes
1.00	2019-03-09	Datasheet created

Trademarks

All referenced product or service names and trademarks are the property of their respective owners.

Edition 2019-03-09

Published by
Infineon Technologies AG
81726 Munich, Germany

© 2019 Infineon Technologies AG
All Rights Reserved.

Do you have a question about any aspect of this document?
Email: erratum@infineon.com

Document reference
IFX-fst1527583024507

IMPORTANT NOTICE

The information given in this document shall in no event be regarded as a guarantee of conditions or characteristics ("Beschaffheitsgarantie").

With respect to any examples, hints or any typical values stated herein and/or any information regarding the application of the product, Infineon Technologies hereby disclaims any and all warranties and liabilities of any kind, including without limitation warranties of non-infringement of intellectual property rights of any third party.

In addition, any information given in this document is subject to customer's compliance with its obligations stated in this document and any applicable legal requirements, norms and standards concerning customer's products and any use of the product of Infineon Technologies in customer's applications.

The data contained in this document is exclusively intended for technically trained staff. It is the responsibility of customer's technical departments to evaluate the suitability of the product for the intended application and the completeness of the product information given in this document with respect to such application.

WARNINGS

Due to technical requirements products may contain dangerous substances. For information on the types in question please contact your nearest Infineon Technologies office.

Except as otherwise explicitly approved by Infineon Technologies in a written document signed by authorized representatives of Infineon Technologies, Infineon Technologies' products may not be used in any applications where a failure of the product or any consequences of the use thereof can reasonably be expected to result in personal injury