

# HITFET™

Smart Low Side Power Switch

## BTS3256D

10 mΩ smart power single channel low side switch with restart and variable slew rate

## Datasheet

Rev. 1.0, 2009-05-05

Automotive

## Table of Contents

|           |  |    |
|-----------|--|----|
|           | <b>Table of Contents</b> .....                             | 2  |
| <b>1</b>  | <b>Overview</b> .....                                      | 3  |
| <b>2</b>  | <b>BTS 3256D Block Diagram</b> .....                       | 5  |
| 2.1       | Voltage and current naming definition .....                | 5  |
| <b>3</b>  | <b>Pin Configuration</b> .....                             | 6  |
| 3.1       | Pin Assignment BTS 3256D .....                             | 6  |
| 3.2       | Pin Definitions and Functions .....                        | 6  |
| <b>4</b>  | <b>General Product Characteristics</b> .....               | 7  |
| 4.1       | Absolute Maximum Ratings .....                             | 7  |
| 4.2       | Functional Range .....                                     | 8  |
| 4.3       | Thermal Resistance .....                                   | 8  |
| <b>5</b>  | <b>Supply and Input Stage</b> .....                        | 10 |
| 5.1       | Supply Circuit .....                                       | 10 |
| 5.1.1     | Under Voltage Lock Out / Power On Reset .....              | 10 |
| 5.2       | Input Circuit .....  | 10 |
| 5.3       | Electrical Characteristics - Supply and Input Stages ..... | 12 |
| <b>6</b>  | <b>Power Stage</b> .....                                   | 13 |
| 6.1       | Output On-state Resistance .....                           | 13 |
| 6.2       | Output Timings and Slopes .....                            | 14 |
| 6.3       | Inductive Output Clamp .....                               | 14 |
| 6.4       | Electrical Characteristics - Power Stage .....             | 17 |
| <b>7</b>  | <b>Control and Diagnosis</b> .....                         | 20 |
| 7.1       | Readout of Fault Information .....                         | 20 |
| 7.2       | Adjustable Slew Rate .....                                 | 20 |
| 7.3       | Electrical Characteristics - Diagnostic .....              | 21 |
| <b>8</b>  | <b>Protection Functions</b> .....                          | 22 |
| 8.1       | Thermal Protection .....                                   | 22 |
| 8.2       | Over Voltage Protection .....                              | 22 |
| 8.3       | Short Circuit Protection .....                             | 23 |
| 8.4       | Electrical Characteristics - Protection .....              | 25 |
| <b>9</b>  | <b>Application Information</b> .....                       | 26 |
| 9.1       | Dimensioning of serial Resistor at IN pin .....            | 26 |
| 9.2       | Further Application Information .....                      | 27 |
| <b>10</b> | <b>Package Outlines</b> .....                              | 28 |
| <b>11</b> | <b>Revision History</b> .....                              | 29 |



## 1 Overview

The BTS 3256D is a single channel low-side power switch in PG-TO-252-5-11 package providing embedded protective functions. This HITFET™ is designed for automotive and industrial applications with outstanding protection and control features. The power transistor is a N-channel vertical power MOSFET. The device is controlled by a chip in Smart Power Technology.

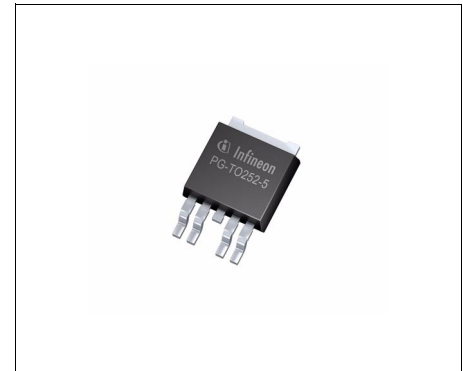

**PG-TO-252-5-11**

### Basic Features

- Slew rate control by dedicated pin enabling EMC optimized switching or PWM operation
- Max. switching Frequency 12kHz
- Clear detection of digital fault signal also during fast PWM operation due to restart delay time
- Thermal and overload protection with time controlled auto restart behavior
- Time and Power limited active current limitation
- Minimum  $R_{DS(on)}$  achieved with 3.3V or 5V logic input
- Electrostatic discharge protection (ESD)
- Very low leakage current
- Green Product (RoHS compliant)
- AEC (Automotive Electronics Council) Stress Test Qualification

**Table 1 Basic Electrical Data**

|  |                  |                |
|--|------------------|----------------|
| Operating voltage  | $V_{SOP}$        | 5.5 V.... 30 V |
| Over voltage protection                                  | $V_D (AZ)$       | 40 V           |
| Maximum ON State resistance at $T_j = 150^\circ\text{C}$ | $R_{DS(ON,max)}$ | 20 m $\Omega$  |
| Typical ON State resistance at $T_j = 25^\circ\text{C}$  | $R_{DS(ON,typ)}$ | 10 m $\Omega$  |
| Nominal load current                                     | $I_{D(nom)}$     | 7.5 A          |
| Minimum current limitation                               | $I_{D(lim)}$     | 42 A           |

| Type      | Package        |
|-----------|----------------|
| BTS 3256D | PG-TO-252-5-11 |

**Digital Diagnostic Features**

- Over temperature
- Over load
- Short circuit
- Clear detection due to a restart delay time

**Protection Functions**

- Enhanced short circuit protection with time and power limited active current limitation
- Under voltage lock out
- Over temperature with time and temperature controlled auto restart
- Over load with power and time controlled auto restart
- ESD protection

**Application**

- All types of resistive, inductive and capacitive loads
- Suitable for loads with inrush current, such as motors, coils, solenoids or lamps
- Suitable for EMC optimized switching in slow operation mode
- Suitable for higher speed PWM controlled loads in fast operation mode
- Replacement of electromechanical relays, fuses and discrete circuits
- Micro controller compatible low side power switch with digital feedback for 12V loads

**Detailed Description**

The BTS 3256D is an autorestart single channel low-side power switch in PG-TO-252-5-11 package providing embedded protective functions. The device is able to switch all kind of resistive, inductive and capacitive loads.

The ESD protection of the  $V_S$  and IN/Fault pin is referenced to GND.

The BTS 3256D is supplied by the  $V_S$  Pin. This Pin should be connected to a reverse protected battery line. The supply voltage is monitored by the under voltage lock out circuit. The Gate driving unit allows the device to operate in the lowest ohmic range independent of the input signal level, 3.3 V or 5 V. For slow PWM application the device offers smooth turn-on and off due to the embedded edge shaping function, to reduce EMC noise. Furthermore the SRP pin can be used to customize the slew rate of the device in a wide range.

The Device is designed for driving automotive loads like motors, valves, coils or bulbs in continuous or PWM mode. The over voltage protection is for protection during load-dump or inductive turn off conditions. The power MOSFET is limiting the Drain-Source voltage to a specified level. This function is available even without any supply.

The over temperature protection prevents the device from overheating due to overload and/or bad cooling conditions. In order to reduce the device stress the edge shaping is disabled during thermal shutdown. After thermal shutdown the device stays off for the specified restart delay time to enable a clear feedback readout on the microcontroller. After this time the device follows the IN signal state.

At high dynamic overload conditions, such as short circuit, the device will either turn off immediately due to the implemented over power limitation, or limit the current for a specified time and then switch off for the restart delay time. Shutdown of the device is triggered if the power dissipation during limitation is above the over power threshold. The short circuit shutdown is a timed restart function. The device will stay off for the specified time and afterwards follow the IN signal state. In order to reduce the device stress the edge shaping is disabled during protective turn off.

## 2 BTS 3256D Block Diagram

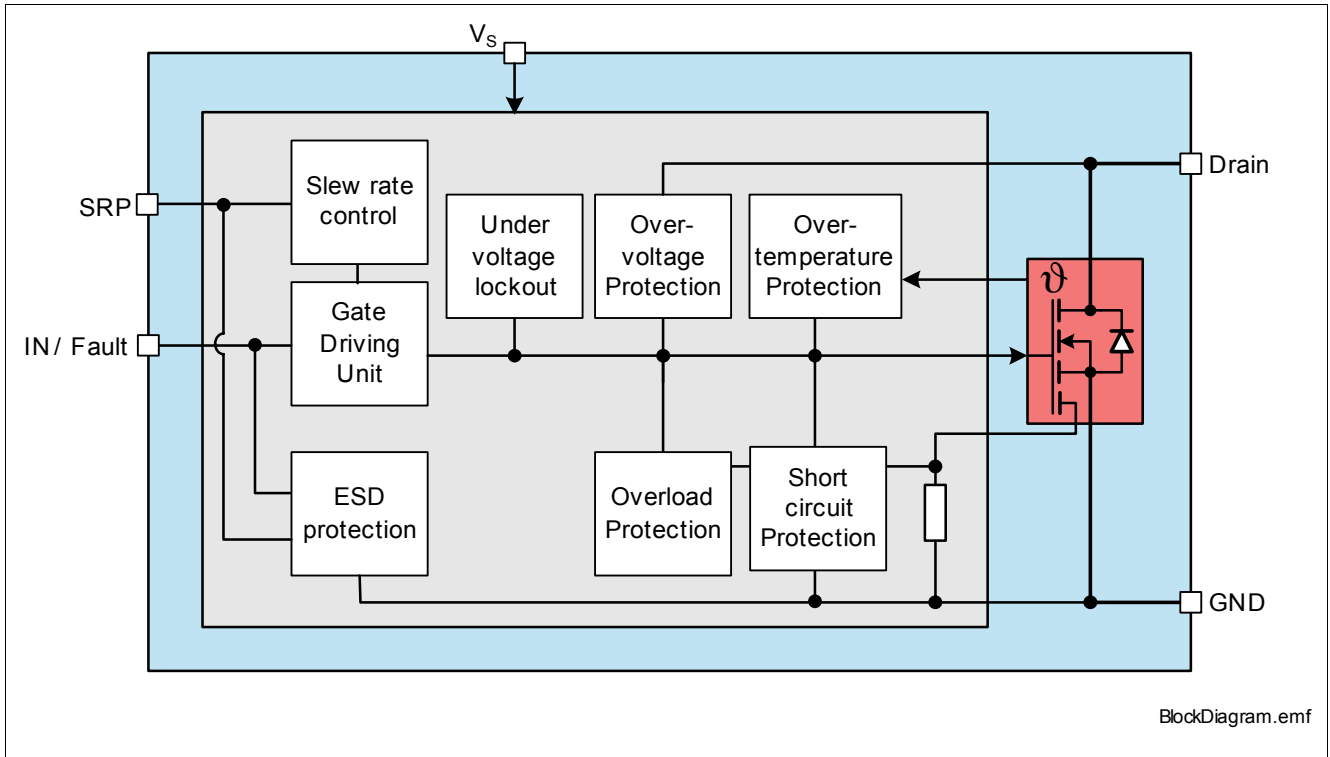

Figure 1 Block Diagram for the BTS3256D

### 2.1 Voltage and current naming definition

Following figure shows all the terms used in this datasheet, with associated convention for positive values.

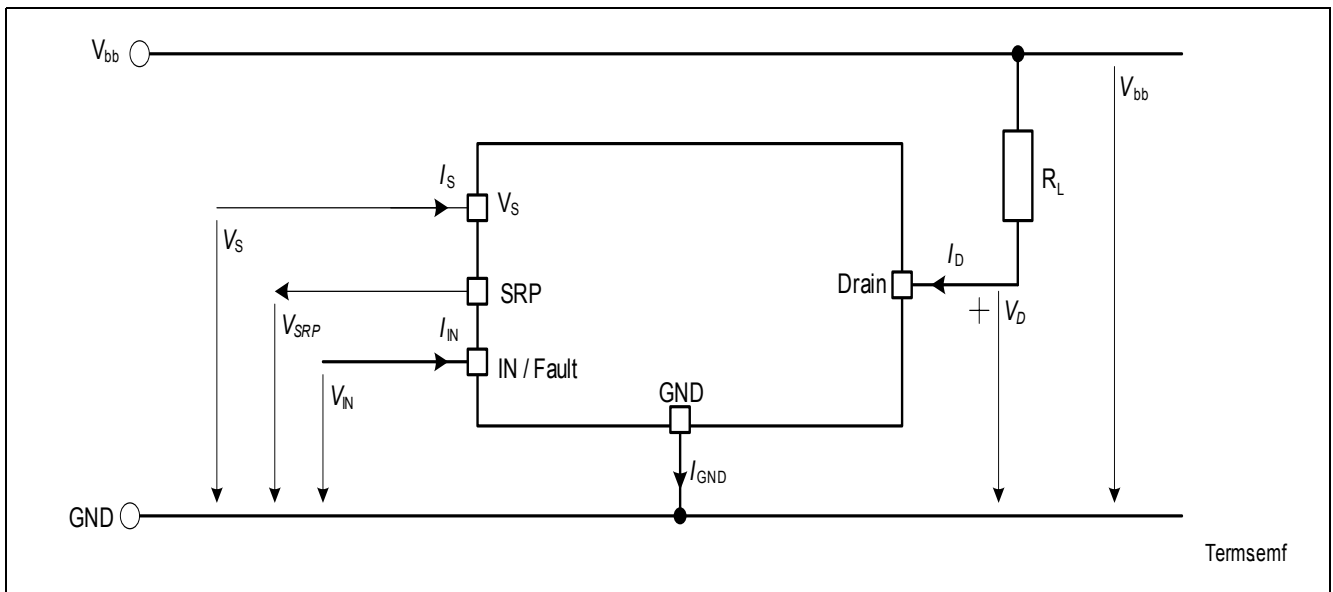

Figure 2 Terms

### 3 Pin Configuration

#### 3.1 Pin Assignment BTS 3256D

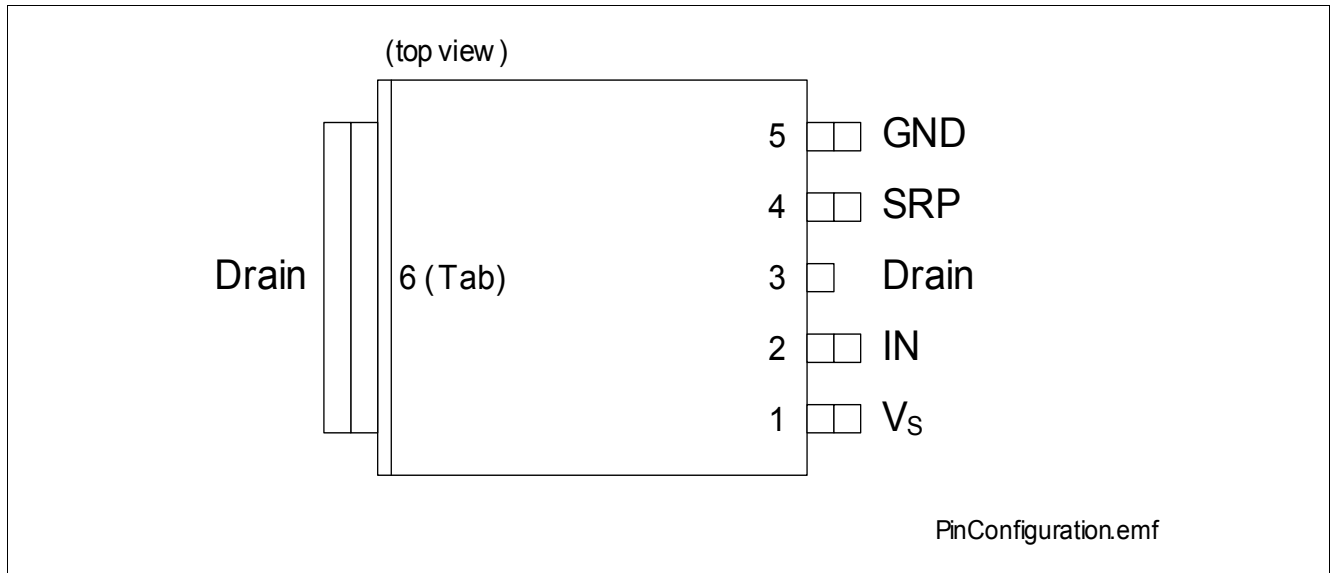

Figure 3 Pin Configuration

#### 3.2 Pin Definitions and Functions

| Pin    | Symbol | Function  |
|--------|--------|---|
| 1      | $V_S$  | <b>Supply Voltage;</b><br>Connected to Battery Voltage with Reverse protection Diode and Filter against EMC |
| 2      | IN     | <b>Control Input and Status Feedback;</b> Digital input 3.3 V or 5 V logic.                                 |
| 3, Tab | Drain  | <b>Drain output;</b><br>Protected low side power output channel, usually connected via load to battery      |
| 4      | SRP    | <b>Slew Rate Preset;</b> Used to define slew rate, see <a href="#">Chapter 7.2</a> for details              |
| 5      | GND    | <b>Ground;</b> Power ground, pin connection needs to carry the load current from Drain                      |

## 4 General Product Characteristics

### 4.1 Absolute Maximum Ratings

#### Absolute Maximum Ratings <sup>1)</sup>

$T_j = -40\text{ °C to }+150\text{ °C}$

All voltages with respect to ground, positive current flowing into pin (unless otherwise specified)

| Pos.                      | Parameter                                  | Symbol                | Limit Values |                  | Unit | Conditions                                     |
|---------------------------|--|-----------------------|--------------|------------------|------|--|
|                           |  |                       | Min.         | Max.             |      |  |
| <b>Voltages</b>           |  |                       |              |                  |      |  |
| 4.1.1                     | Supply voltage                             | $V_S$                 | -0.3         | 30               | V    | –  |
| 4.1.2                     | Supply voltage during active clamping      | $V_{S(\text{pulse})}$ | -0.3         | 45 <sup>2)</sup> | V    | –  |
| 4.1.3                     | Drain voltage                              | $V_D$                 | -0.3         | 40 <sup>3)</sup> | V    | –  |
| 4.1.4                     | Drain voltage for short circuit protection | $V_{D(\text{SC})}$    | 0            | 30               | V    | <sup>4)</sup>                                  |
| 4.1.5                     | Logic input voltage                        | $V_{IN}$              | -0.3         | 5.5              | V    | –  |
| 4.1.6                     | Slew Rate Preset maximum voltages          | $V_{SRP}$             | -0.3         | 5.5              | V    | <sup>5)</sup>                                  |
| <b>Energies</b>           |  |                       |              |                  |      |  |
| 4.1.7                     | Unclamped single pulse inductive energy    | $E_{AS}$              | 0            | 0.3              | J    | $I_D = 22\text{ A};$<br>$V_{bb} = 30\text{ V}$ |
| <b>Temperatures</b>       |  |                       |              |                  |      |  |
| 4.1.8                     | Junction Temperature                       | $T_j$                 | -40          | 150              | °C   | –  |
| 4.1.9                     | Storage Temperature                        | $T_{stg}$             | -55          | 150              | °C   | –  |
| <b>ESD Susceptibility</b> |  |                       |              |                  |      |  |
| 4.1.10                    | ESD Resistivity                            | $V_{ESD}$             |              |                  | kV   | HBM <sup>6)</sup>                              |
|                           | on input pins (IN,SRP,VS)                  | IN                    | -4           | 4                |      |  |
|                           | on Drain and GND pins                      | OUT                   | -8           | 8                |      |  |

1) Not subject to production test, specified by design.

2) Not for DC operation, only for short pulse (i.e. loaddump) for a total of 100 h in full device life.

3) Active clamped.

4) The Device can not be switched on if  $V_D > V_{D(\text{SC})}$

5) SRP Pin is driven by an internal current source, so active driving from outside is not required, it may affect lifetime and could cause parameter shifts outside the range given in datasheet

6) ESD susceptibility, HBM according to EIA/JESD 22-A114B, section4

*Note: Stresses above the ones listed here may cause permanent damage to the device. Exposure to absolute maximum rating conditions for extended periods may affect device reliability.*

*Note: Integrated protection functions are designed to prevent IC destruction under fault conditions described in the data sheet. Fault conditions are considered as "outside" normal operating range. Protection functions are not designed for continuous repetitive operation.*



## 4.2 Functional Range

| Pos.  | Parameter            | Symbol | Limit Values |      | Unit | Conditions |
|-------|----------------------|--------|--------------|------|------|------------|
|       |                      |        | Min.         | Max. |      |            |
| 4.2.1 | Supply Voltage       | $V_S$  | 5.5          | 30   | V    | –          |
| 4.2.2 | Supply current in on | $I_S$  | –            | 3    | mA   | –          |

Note: Within the functional range the IC operates as described in the circuit description. The electrical characteristics are specified within the conditions given in the related electrical characteristics table.

## 4.3 Thermal Resistance

| Pos.  | Parameter                         | Symbol     | Limit Values |      |      | Unit | Conditions   |
|-------|-----------------------------------|------------|--------------|------|------|------|--|
|       |                                   |            | Min.         | Typ. | Max. |      |  |
| 4.3.1 | Junction to Case <sup>1)</sup>    | $R_{thjC}$ | –            | 0.9  | 1.1  | K/W  | –  |
| 4.3.2 | Junction to ambient <sup>1)</sup> | $R_{thjA}$ | –            | 80   | –    | K/W  | @min. footprint  |
|       |                                   |            | –            | 45   | –    | K/W  | @ 6 cm <sup>2</sup> cooling area, see <a href="#">Figure 4</a> |

1) Not subject to production test, specified by design



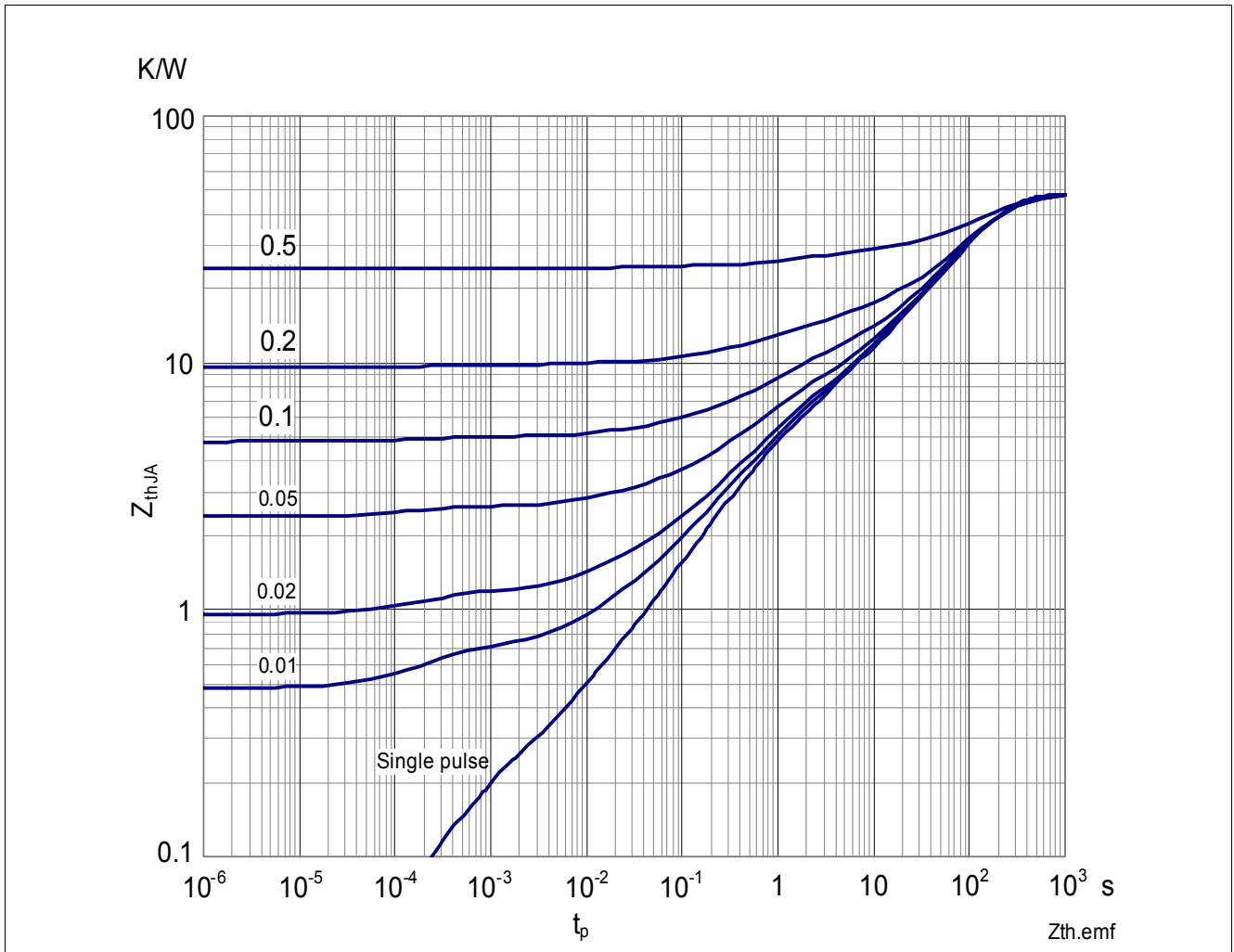

**Figure 4 Typical transient thermal impedance**  
 $Z_{thJA} = f(t_p)$ , Pulse D =  $t_p/T$ ,  $T_a = 25\text{ °C}$   
 Device on 50 mm × 50 mm × 1.5 mm epoxy PCB FR4 with 6 cm<sup>2</sup> (one layer, 70 μm thick) copper area for drain connection. PCB mounted vertical without blown air.

## 5 Supply and Input Stage

### 5.1 Supply Circuit

The Supply pin  $V_S$  is protected against ESD pulses as shown in [Figure 5](#).

Due to an internal voltage regulator the device can be supplied from a reverse polarity protected battery line.

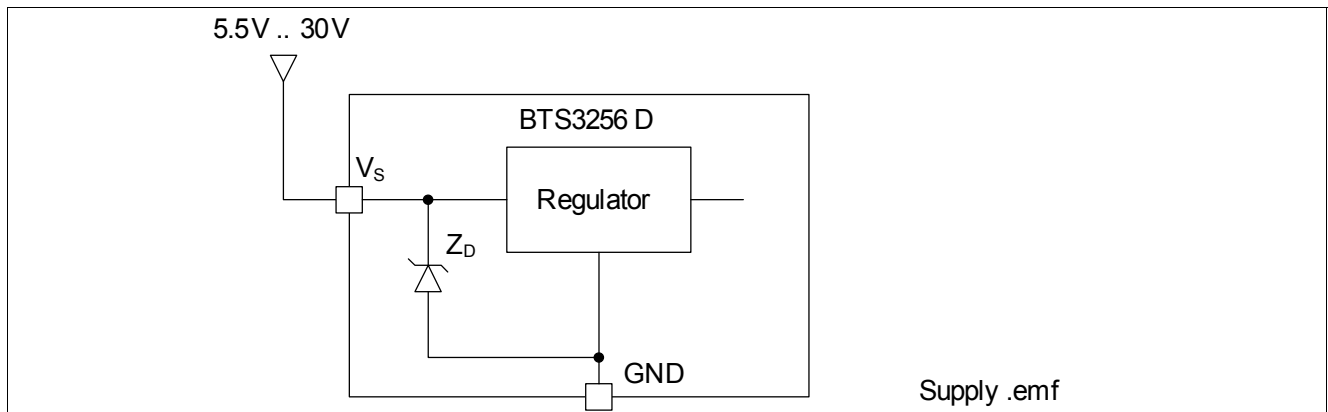

Figure 5 Supply Circuit

#### 5.1.1 Under Voltage Lock Out / Power On Reset

In order to ensure a stable device behavior under all allowed conditions the Supply voltage  $V_S$  is monitored by the under voltage lock out circuit. All device functions are only given for supply voltages above under voltage lockout. There is no failure feedback for  $V_S < V_{SUVON}$ .

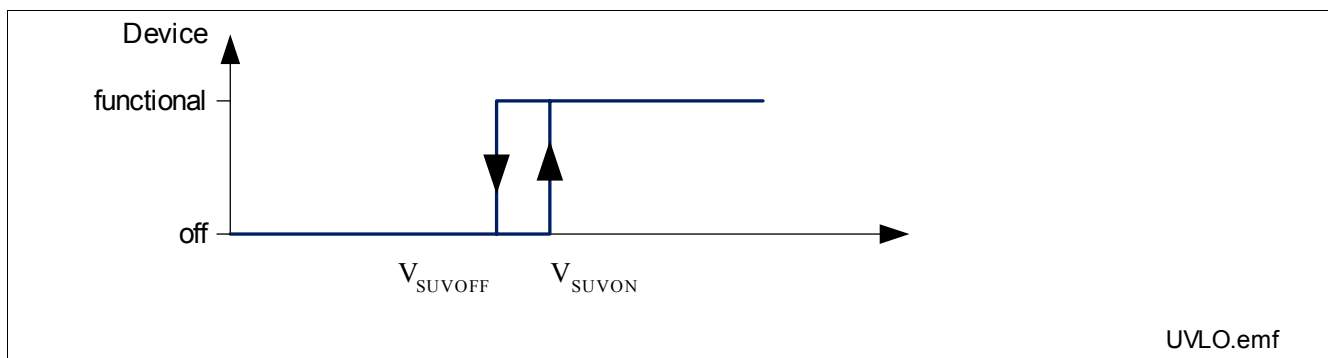

Figure 6 Under Voltage Lock Out

### 5.2 Input Circuit

[Figure 7](#) shows the input circuit of the BTS 3256D. It's ensured that the device switches off in case of open input pin. A Zener structure protects the input circuit against ESD pulses. As the BTS 3256D has a supply pin, the operation of the power MOS can be maintained regardless of the voltage on the IN pin, therefore a digital status feedback down to logic low is realized. For readout of the fault information, please refer to Diagnosis "[Readout of Fault Information](#)" on [Page 20](#).

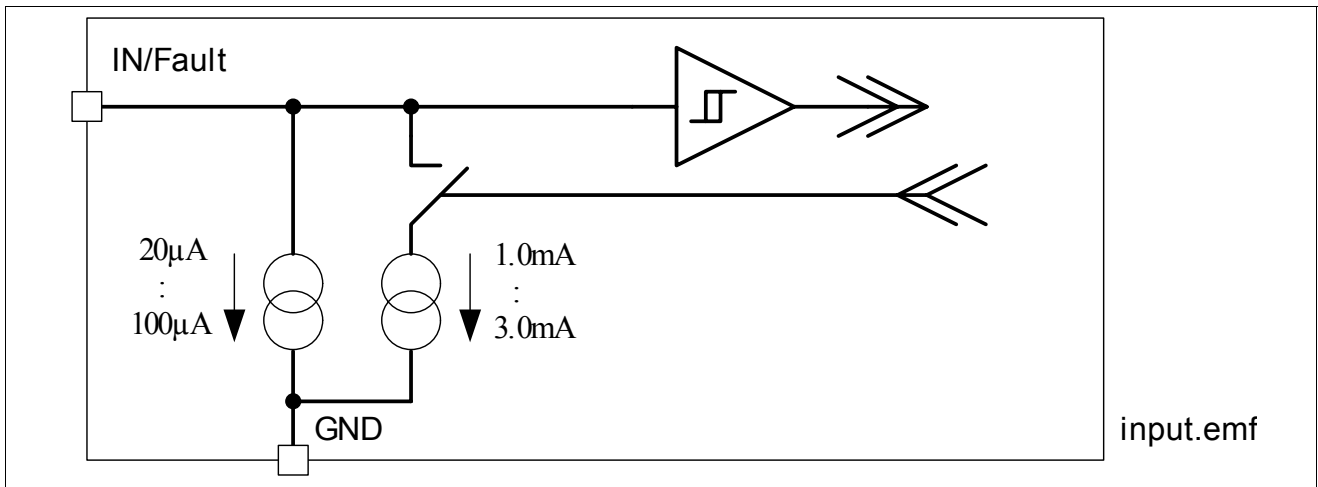

Figure 7 Input Circuit

### 5.3 Electrical Characteristics - Supply and Input Stages

$V_S = 5.5 \text{ V to } 30 \text{ V}$ ,  $T_j = -40 \text{ }^\circ\text{C to } +150 \text{ }^\circ\text{C}$

All voltages with respect to ground, positive current flowing into pin (unless otherwise specified)

| Pos.                                  | Parameter                        | Symbol                | Limit Values |      |      | Unit          | Conditions  |
|---------------------------------------|----------------------------------|-----------------------|--------------|------|------|---------------|---|
|                                       |                                  |                       | Min.         | Typ. | Max. |               |   |
| <b>Under Voltage Lockout</b>          |                                  |                       |              |      |      |               |   |
| 5.3.1                                 | UV-switch-on voltage             | $V_{\text{SUVON}}$    | –            | –    | 5.6  | V             | –   |
| 5.3.2                                 | UV-switch-off voltage            | $V_{\text{SUVOFF}}$   | 4.0          | –    | 5.5  | V             | –   |
| 5.3.3                                 | UV-switch-off hysteresis         | $V_{\text{SUVHY}}$    | –            | 0.2  | –    | V             | $V_{\text{SUVON}} - V_{\text{SUVOFF}}$                  |
| <b>Digital Input / Fault Feedback</b> |                                  |                       |              |      |      |               |   |
| 5.3.4                                 | Low level voltage                | $V_{\text{INL}}$      | -0.3         | –    | 0.8  | V             | –   |
| 5.3.5                                 | High level voltage               | $V_{\text{INH}}$      | 2.0          | –    | 5.5  | V             | –   |
| 5.3.6                                 | Input pull down current          | $I_{\text{IN}}$       | 20           | 50   | 100  | $\mu\text{A}$ | $V_{\text{IN}} = 5.3 \text{ V}$ ;<br>no fault condition |
| 5.3.7                                 | Input pull down current in Fault | $I_{\text{IN-Fault}}$ | 1            | 2    | 3    | mA            | $V_{\text{IN}} = 5.3 \text{ V}$ ; all fault conditions  |

## 6 Power Stage

The power stage is built by a N-channel vertical power MOSFET (DMOS).

### 6.1 Output On-state Resistance

The on-state resistance depends on the junction temperature  $T_J$ . **Figure 8** shows this dependence for the typical on-state resistance  $R_{DS(on)}$ .

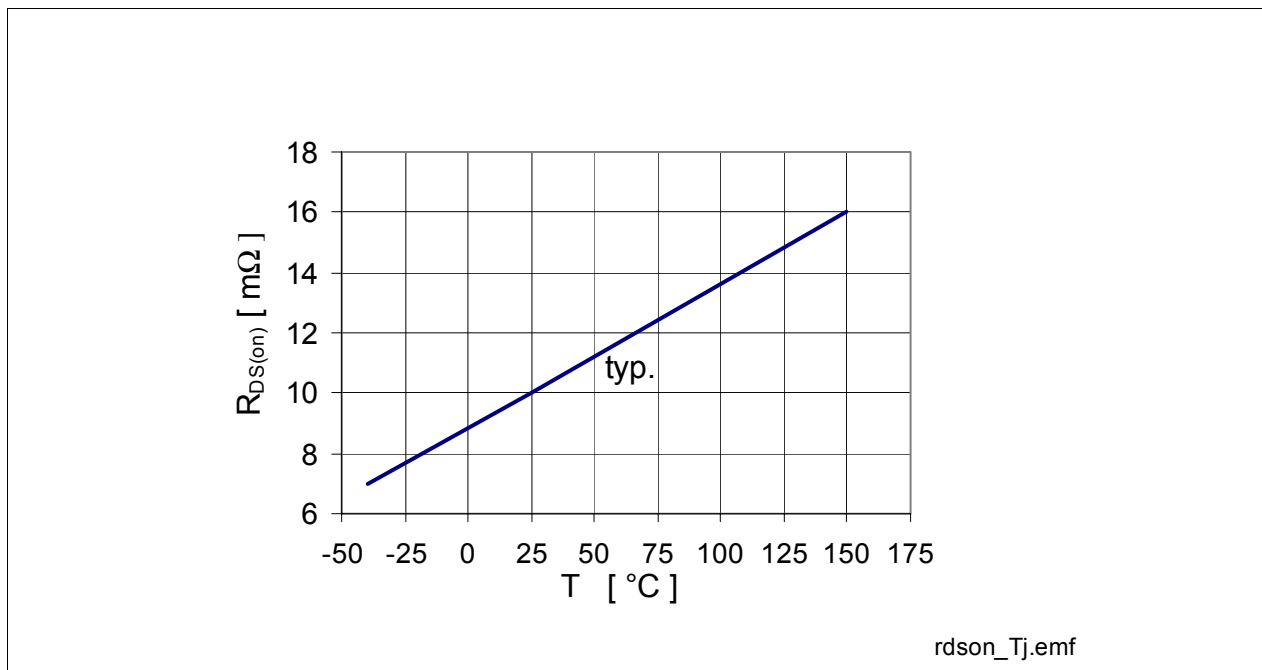

**Figure 8** Typical On-State Resistance  $R_{DS(on)} = f(T_J)$ ,  $V_S = 10\text{ V}$ ,  $V_{IN} = \text{high}$

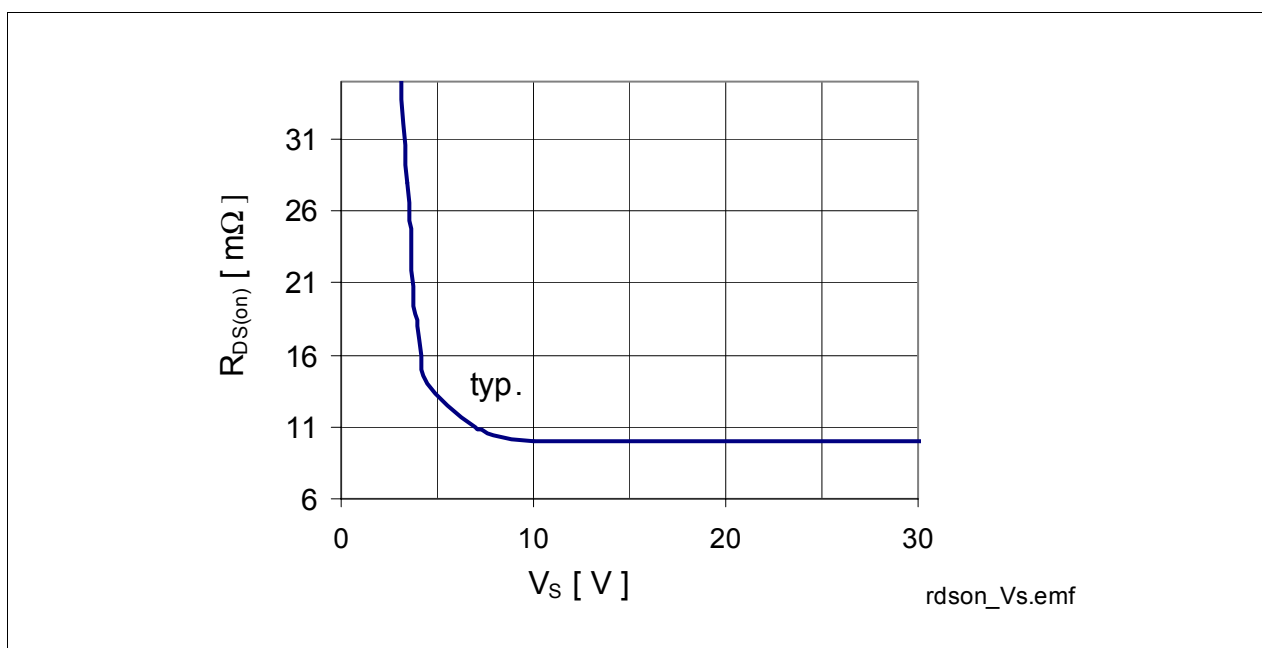

**Figure 9** Typical On-State Resistance  $R_{DS(on)} = f(V_S)$ ,  $V_{IN} = \text{high}$ ,  $T_{\text{ambient}} = 25\text{ °C}$

## 6.2 Output Timings and Slopes

A high signal on the input pin causes the power MOSFET to switch on with a dedicated slope which is optimized for low EMC emission. **Figure 10** shows the timing definition.

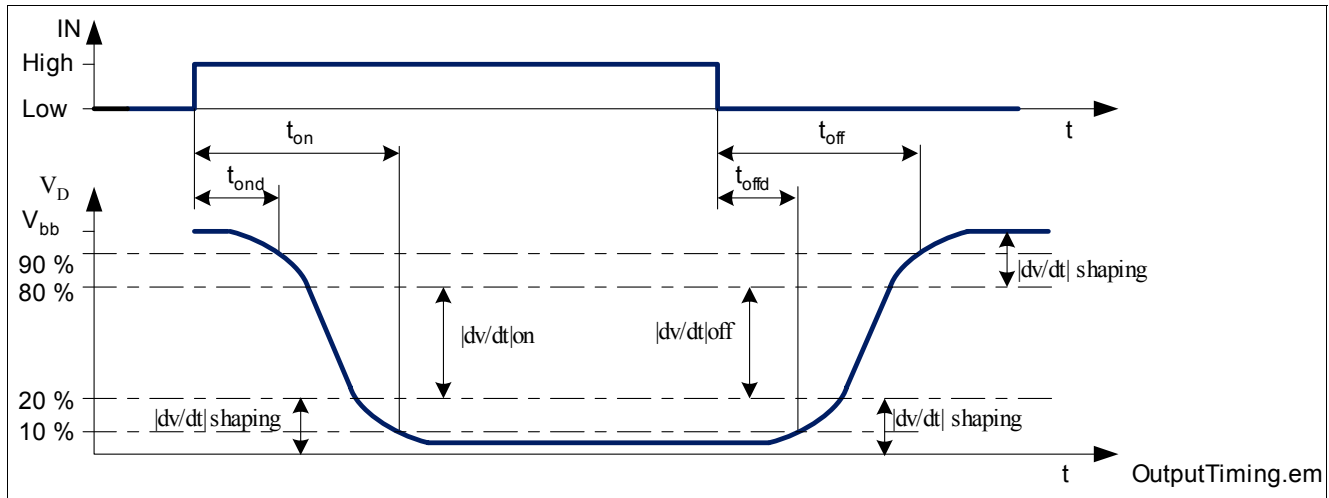

**Figure 10** Definition of Power Output Timing for Resistive Load

In order to minimize the emission during switching, the BTS 3256D limits the slopes during turn on and off at slow slew rate settings. For best performance of the edge shaping, the supply pin  $V_S$  should be connected to battery voltage. For supply voltages other than nominal battery, the edge shaping can differ from the Values in the electrical characteristics table below.

## 6.3 Inductive Output Clamp

When switching off inductive loads with low-side switches, the Drain Source voltage  $V_D$  rises above battery potential, because the inductance intends to continue driving the current.

The BTS 3256D is equipped with a voltage clamp mechanism that keeps the Drain-Source voltage  $V_D$  at a certain level. See **Figure 11** for more details.

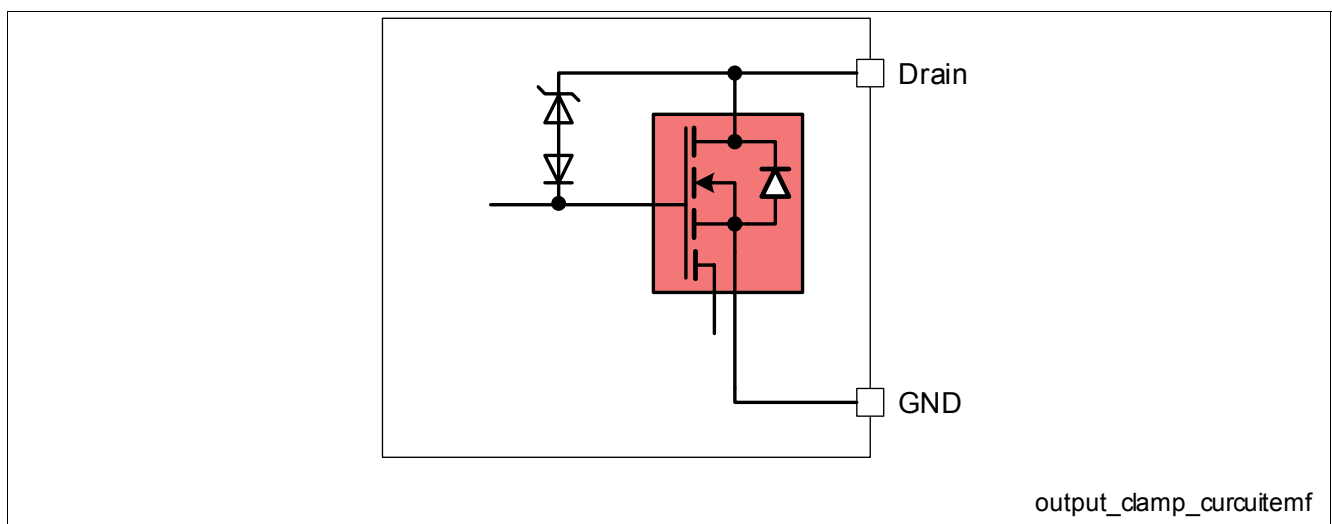

**Figure 11** Output Clamp

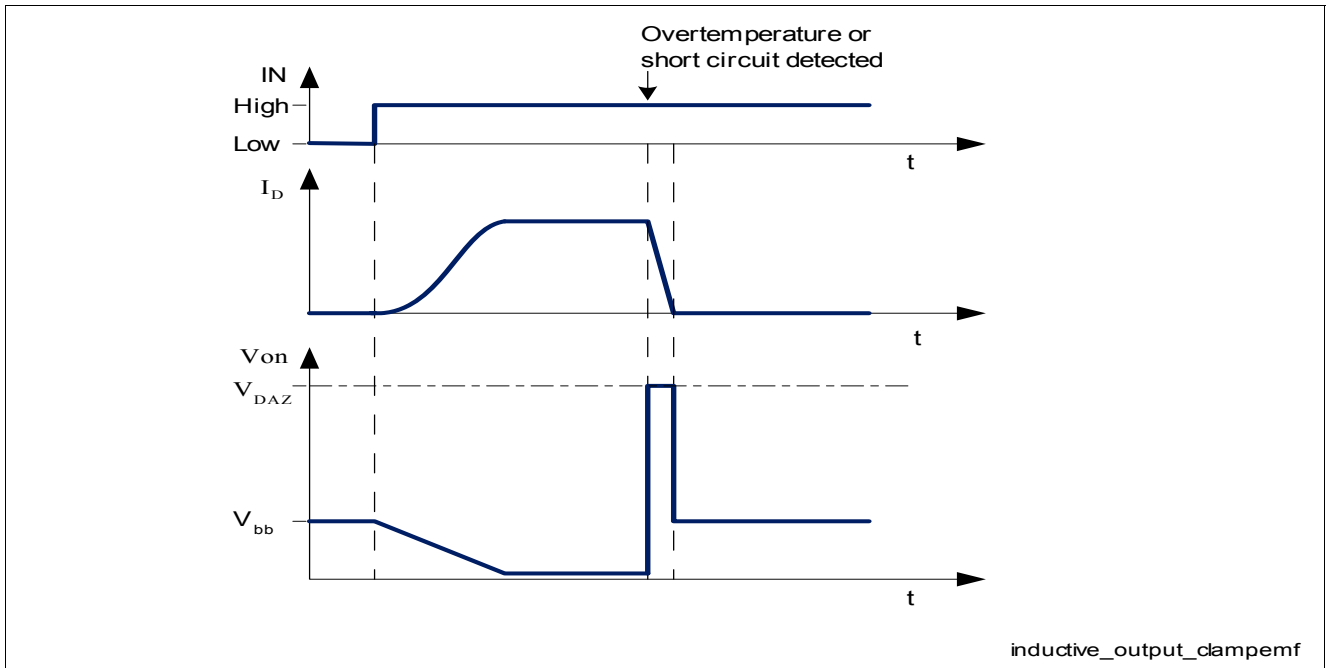

**Figure 12 Switching off an inductive Load**

While demagnetization of inductive loads, energy has to be dissipated in the BTS 3256D. This energy can be calculated with following equation:

$$E = V_{D(AZ)} \cdot \left[ \frac{V_{bb} - V_{D(AZ)}}{R_L} \cdot \ln \left( 1 - \frac{R_L \cdot I_L}{V_{bb} - V_{D(AZ)}} \right) + I_L \right] \cdot \frac{L}{R_L}$$

Following equation simplifies under assumption of  $R_L = 0$

$$E = \frac{1}{2} L I_L^2 \cdot \left( 1 - \frac{V_{bb}}{V_{bb} - V_{D(AZ)}} \right)$$

**Figure 13** shows the inductance / current combination the BTS 3256D can handle.

For maximum single avalanche energy please also refer to  $E_{AS}$  value in **“Energies”** on [Page 7](#).



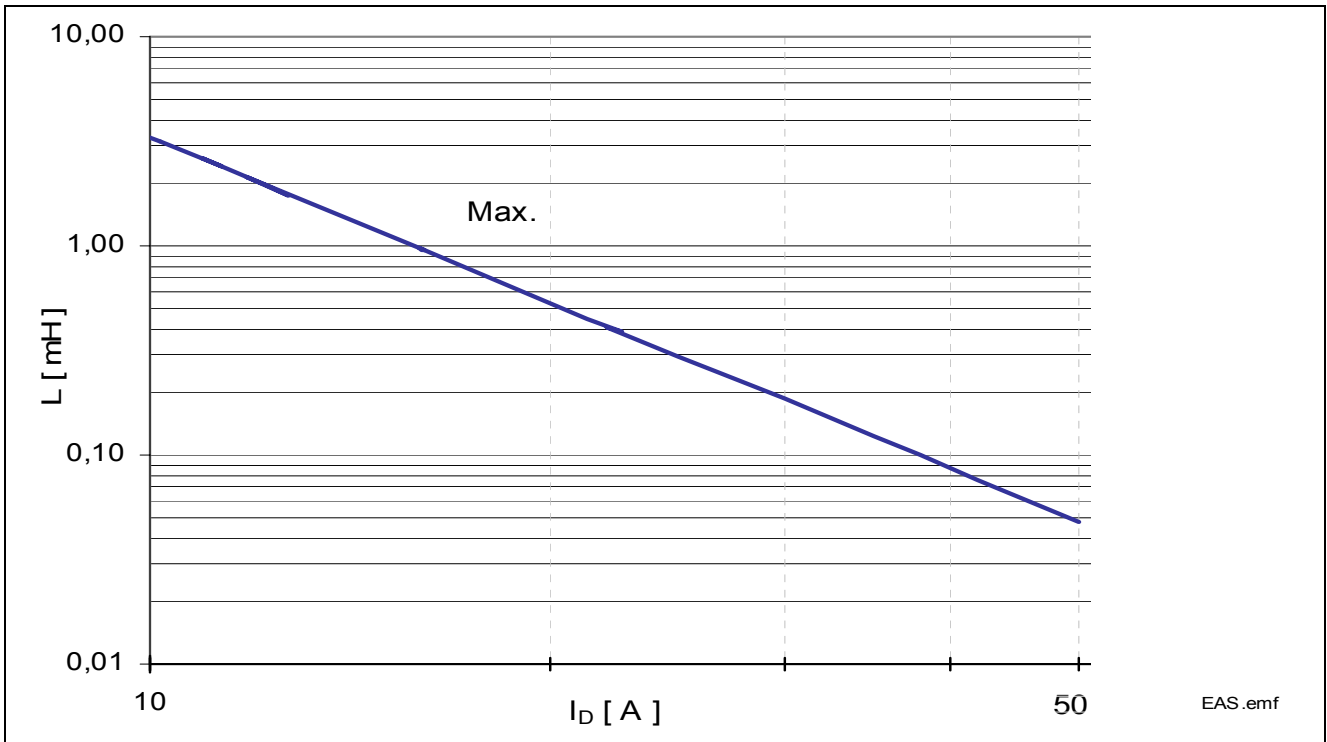

Figure 13 Maximum allowed inductance values for single switch off (EAS)  
 $L = f(I_L)$ ,  $T_{j,start} = 150\text{ °C}$ ,  $V_{bb} = 30\text{V}$ ,  $R_L = 0\ \Omega$

## 6.4 Electrical Characteristics - Power Stage

 $V_S = 5.5 \text{ V to } 30 \text{ V}, T_j = -40 \text{ }^\circ\text{C to } +150 \text{ }^\circ\text{C}$ 

All voltages with respect to ground, positive current flowing into pin (unless otherwise specified)

| Pos.  | Parameter                          | Symbol           | Limit Values |      |      | Unit             | Conditions  |
|---|------------------------------------|------------------|--------------|------|------|------------------|---|
|   |                                    |                  | Min.         | Typ. | Max. |                  |   |
| <b>Power Supply</b>                           |                                    |                  |              |      |      |                  |   |
| 6.4.1   | On-state resistance                | $R_{DS(on)}$     | –            | 10   | –    | m $\Omega$       | $T_J = 25 \text{ }^\circ\text{C};$<br>$I_D = 20 \text{ A};$<br>$V_{IN} = \text{high}$<br>$V_S = 10 \text{ V}$   |
|   |                                    |                  | –            | 16   | 20   | m $\Omega$       | $T_J = 150 \text{ }^\circ\text{C};$<br>$I_D = 20 \text{ A};$<br>$V_{IN} = \text{high}$<br>$V_S = 10 \text{ V}$  |
| 6.4.2   | Nominal load current <sup>1)</sup> | $I_{D(nom)}$     | 7.5          | 8.7  | –    | A                | $T_J < 150 \text{ }^\circ\text{C};$<br>$T_A 85 \text{ }^\circ\text{C SMD}^2);$<br>$V_{IN} = \text{high};$<br>$V_S \geq 10 \text{ V};$<br>$V_{DS} = 0.5 \text{ V}$ |
| 6.4.3   | ISO load current <sup>1)</sup>     | $I_{D(ISO)}$     | 31           | 33   | –    | A                | $T_J < 150 \text{ }^\circ\text{C};$<br>$T_C = 85 \text{ }^\circ\text{C};$<br>$V_{IN} = \text{high}$<br>$V_S \geq 10 \text{ V};$<br>$V_{DS} = 0.5 \text{ V};$      |
| 6.4.4   | Off state drain current            | $I_{DSS}$        | –            | 6    | 12   | $\mu\text{A}$    | $V_D = 32 \text{ V};$<br>$V_{IN} = \text{low}$  |
| 6.4.5   |                                    |                  | –            | 1    | 2    | $\mu\text{A}^1)$ | $T_J = 85 \text{ }^\circ\text{C};$<br>$V_D = 13.5 \text{ V};$<br>$V_{IN} = \text{low}$  |
| <b>Dynamic Characteristics</b>                |                                    |                  |              |      |      |                  |   |
| 6.4.6   | power up settling time             | $t_{init}$       | –            | 10   | 25   | $\mu\text{s}$    | $V_S > 6\text{V}$<br>first rising edge on<br>IN pin.  |
| <b>Timings with fastest slew rate setting</b> |                                    |                  |              |      |      |                  |   |
| 6.4.7   | Turn-on delay                      | $t_{ond\_fast}$  | –            | 4    | 10   | $\mu\text{s}$    | $R_L = 2.2 \text{ } \Omega;$<br>$R_{SRP} = \text{OPEN};$<br>$V_{bb} = V_S = 13.5 \text{ V};$<br>see <a href="#">Figure 10</a>                                     |
| 6.4.8   | Turn-on time                       | $t_{on\_fast}$   | –            | 11   | 22   | $\mu\text{s}$    | $R_L = 2.2 \text{ } \Omega;$<br>$R_{SRP} = \text{OPEN};$<br>$V_{bb} = V_S = 13.5 \text{ V};$<br>see <a href="#">Figure 10</a>                                     |
| 6.4.9   | Turn-off delay                     | $t_{offd\_fast}$ | 4            | 10   | 15   | $\mu\text{s}$    | $R_L = 2.2 \text{ } \Omega;$<br>$R_{SRP} = \text{OPEN};$<br>$V_{bb} = V_S = 13.5 \text{ V};$<br>see <a href="#">Figure 10</a>                                     |

$V_S = 5.5 \text{ V to } 30 \text{ V}, T_j = -40 \text{ }^\circ\text{C to } +150 \text{ }^\circ\text{C}$ 

All voltages with respect to ground, positive current flowing into pin (unless otherwise specified)

| Pos.   | Parameter                     | Symbol                           | Limit Values |      |      | Unit                   | Conditions  |
|--------|-------------------------------|----------------------------------|--------------|------|------|------------------------|---|
|        |                               |                                  | Min.         | Typ. | Max. |                        |   |
| 6.4.10 | Turn-off time                 | $t_{\text{off\_fast}}$           | 9            | 16   | 24   | $\mu\text{s}$          | $R_L = 2.2 \Omega$ ;<br>$R_{\text{SRP}} = \text{OPEN}$ ;<br>$V_{\text{bb}} = V_S = 13.5 \text{ V}$ ;<br>see <a href="#">Figure 10</a>               |
| 6.4.11 | Slew rate on                  | $-dV_D/dt_{\text{on\_fast}}$     | 1.2          | 2.2  | 3.8  | $\text{V}/\mu\text{s}$ | $R_L = 2.2 \Omega$ ;<br>$R_{\text{SRP}} = \text{OPEN}$ ;<br>$V_{\text{bb}} = V_S = 13.5 \text{ V}$ ;<br>see <a href="#">Figure 10</a>               |
| 6.4.12 | Slew rate off                 | $dV_D/dt_{\text{off\_fast}}$     | 1.2          | 2.2  | 3.8  | $\text{V}/\mu\text{s}$ | $R_L = 2.2 \Omega$ ;<br>$R_{\text{SRP}} = \text{OPEN}$ ;<br>$V_{\text{bb}} = V_S = 13.5 \text{ V}$ ;<br>see <a href="#">Figure 10</a>               |
| 6.4.13 | Slew rate during edge shaping | $ dV/dt _{\text{shaping\_fast}}$ | –            | 0.66 | –    | $\text{V}/\mu\text{s}$ | <sup>1)</sup> $R_L = 2.2 \Omega$ ;<br>$R_{\text{SRP}} = \text{OPEN}$ ;<br>$V_{\text{bb}} = V_S = 13.5 \text{ V}$ ;<br>see <a href="#">Figure 10</a> |

**Timings with slowest slew rate setting**

|        |                |                         |    |     |     |               |  |
|--------|----------------|-------------------------|----|-----|-----|---------------|--|
| 6.4.14 | Turn-on delay  | $t_{\text{ond\_slow}}$  | –  | 22  | 60  | $\mu\text{s}$ | $R_L = 2.2 \Omega$ ;<br>$R_{\text{SRP}} = \text{GND}$ ;<br>$V_{\text{bb}} = V_S = 13.5 \text{ V}$ ;<br>see <a href="#">Figure 10</a> |
| 6.4.15 | Turn-on time   | $t_{\text{on\_slow}}$   | –  | 85  | 200 | $\mu\text{s}$ | $R_L = 2.2 \Omega$ ;<br>$R_{\text{SRP}} = \text{GND}$ ;<br>$V_{\text{bb}} = V_S = 13.5 \text{ V}$ ;<br>see <a href="#">Figure 10</a> |
| 6.4.16 | Turn-off delay | $t_{\text{offd\_slow}}$ | –  | 75  | 110 | $\mu\text{s}$ | $R_L = 2.2 \Omega$ ;<br>$R_{\text{SRP}} = \text{GND}$ ;<br>$V_{\text{bb}} = V_S = 13.5 \text{ V}$ ;<br>see <a href="#">Figure 10</a> |
| 6.4.17 | Turn-off time  | $t_{\text{off\_slow}}$  | 40 | 150 | 220 | $\mu\text{s}$ | $R_L = 2.2 \Omega$ ;<br>$R_{\text{SRP}} = \text{GND}$ ;<br>$V_{\text{bb}} = V_S = 13.5 \text{ V}$ ;<br>see <a href="#">Figure 10</a> |

$V_S = 5.5 \text{ V to } 30 \text{ V}, T_j = -40 \text{ }^\circ\text{C to } +150 \text{ }^\circ\text{C}$ 

All voltages with respect to ground, positive current flowing into pin (unless otherwise specified)

| Pos.                 | Parameter                     | Symbol                    | Limit Values |       |      | Unit       | Conditions  |
|----------------------|-------------------------------|---------------------------|--------------|-------|------|------------|---|
|                      |                               |                           | Min.         | Typ.  | Max. |            |   |
| 6.4.18               | Slew rate on                  | $-dV_D/dt_{on\_slow}$     | 0.08         | 0.2   | 0.6  | V/ $\mu$ s | $R_L = 2.2 \text{ } \Omega$ ;<br>$R_{SRP} = \text{GND}$ ;<br>$V_{bb} = V_S = 13.5 \text{ V}$<br>see <a href="#">Figure 10</a>               |
| 6.4.19               | Slew rate off                 | $dV_D/dt_{off\_slow}$     | 0.08         | 0.2   | 0.6  | V/ $\mu$ s | $R_L = 2.2 \text{ } \Omega$ ;<br>$R_{SRP} = \text{GND}$ ;<br>$V_{bb} = V_S = 13.5 \text{ V}$<br>see <a href="#">Figure 10</a>               |
| 6.4.20               | Slew rate during edge shaping | $ dV/dt _{shaping\_slow}$ | –            | 0.088 | –    | V/ $\mu$ s | <sup>1)</sup> $R_L = 2.2 \text{ } \Omega$ ;<br>$R_{SRP} = \text{GND}$ ;<br>$V_{bb} = V_S = 13.5 \text{ V}$<br>see <a href="#">Figure 10</a> |
| <b>Inverse Diode</b> |                               |                           |              |       |      |            |   |
| 6.4.21               | Inverse Diode forward voltage | $V_D$                     | -0.3         | -1.0  | -1.5 | V          | $I_D = -12 \text{ A}$ ;<br>$V_S = 0 \text{ V}$ ;<br>$V_{IN} = 0.0 \text{ V}$  |

1) Not subject to production test, specified by Design.

 2) Device mounted according to EIA/JESD 52\_2, FR4,  $50 \times 50 \times 1.5 \text{ mm}$ ;  $35 \mu \text{ Cu}$ ,  $5 \mu \text{ Sn}$ ;  $6 \text{ cm}^2$ .  
PCB mounted without blown air

## 7 Control and Diagnosis

The BTS3256D provides digital fault feedback on the IN pin without the need of an ADC. Additionally the device features an adjustable slew rate via the SRP pin.

### 7.1 Readout of Fault Information

The BTS 3256D provides digital status information via an increased current on the IN / Fault pin. The voltage on this pin is pulled down to logic low when a fitting serial resistor is used. An example for the required circuitry is shown in **Figure 14**. The increased current  $I_{IN(fault)}$  is one order of magnitude above the normal operation current  $I_{IN}$ .

A 3k3 for a 3.3V  $\mu$ C or 5k6 for a 5V  $\mu$ C is recommended.

For detailed calculation please refer to **“Dimensioning of serial Resistor at IN pin” on Page 26**.

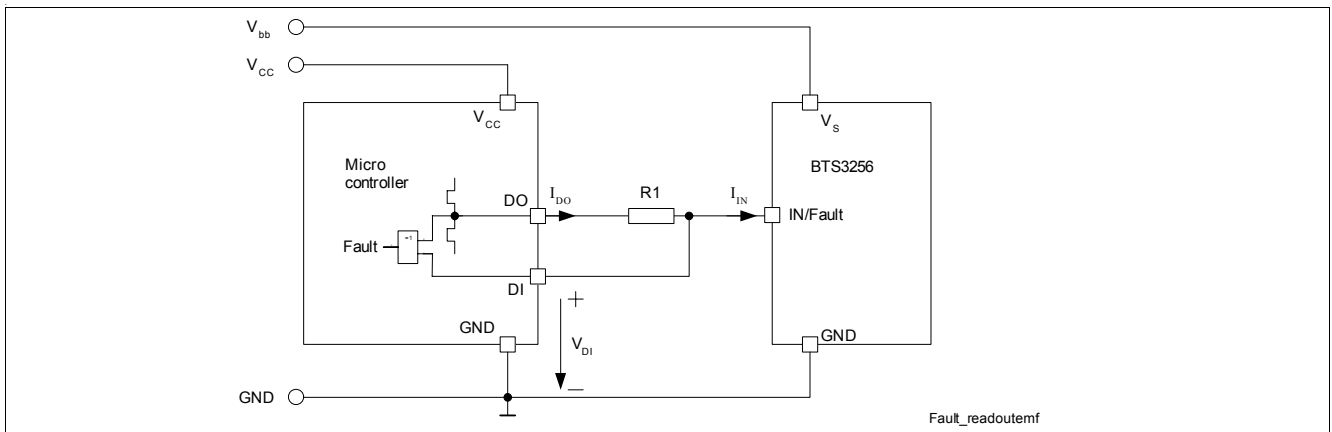

**Figure 14** Readout of feedback information and XOR logic in micro

### 7.2 Adjustable Slew Rate

In order to optimize electromagnetic emission, the switching speed of the MOSFET can be adjusted by connecting an external resistor between SRP pin and GND. This allows for balancing between electromagnetic emissions and power dissipation.  $R_{SRP-min}$  represents the minimum slew rate  $Slew\ rate_{min}$  and  $R_{SRP-max}$  represents the maximum slew rate  $Slew\ rate_{max}$ .

A short to GND causes the minimum slew rate  $Slew\ rate_{min}$ .

Open pin condition causes the maximum Slew rate  $Slew\ rate_{max}$ .

**Figure 15** shows the relation between the resistor value and the slew rate of BTS 3256D.

### 7.3 Electrical Characteristics - Diagnostic

$V_S = 5.5 \text{ V to } 30 \text{ V}$ ,  $T_j = -40 \text{ }^\circ\text{C to } +150 \text{ }^\circ\text{C}$

All voltages with respect to ground, positive current flowing into pin (unless otherwise specified)

| Pos.                     | Parameter          | Symbol             | Limit Values |      |      | Unit       | Conditions  |
|--------------------------|--------------------|--------------------|--------------|------|------|------------|---|
|                          |                    |                    | Min.         | Typ. | Max. |            |   |
| <b>Slew rate control</b> |                    |                    |              |      |      |            |   |
| 7.3.1                    | $Slew\ rate_{min}$ | $Slew\ rate_{min}$ | 0.08         | 0.2  | 0.6  | V/ $\mu$ s | $R_{SRP} = 0 \text{ Ohm}$<br>$V_S = 13.5 \text{ V}$ ;<br>ohmic load   |
| 7.3.2                    | $Slew\ rate_{15k}$ | $Slew\ rate_{15k}$ | 0.2          | 0.6  | –    | V/ $\mu$ s | $R_{SRP} = 15 \text{ kOhm}$<br>$V_S = 13.5 \text{ V}$ ;<br>ohmic load |
| 7.3.3                    | $Slew\ rate_{30k}$ | $Slew\ rate_{30k}$ | 0.7          | 1.45 | –    | V/ $\mu$ s | $R_{SRP} = 30 \text{ kOhm}$<br>$V_S = 13.5 \text{ V}$ ;<br>ohmic load |
| 7.3.4                    | $Slew\ rate_{max}$ | $Slew\ rate_{max}$ | 1.2          | 2.2  | 3.8  | V/ $\mu$ s | SRP pin open<br>$V_S = 13.5 \text{ V}$ ;<br>ohmic load                |

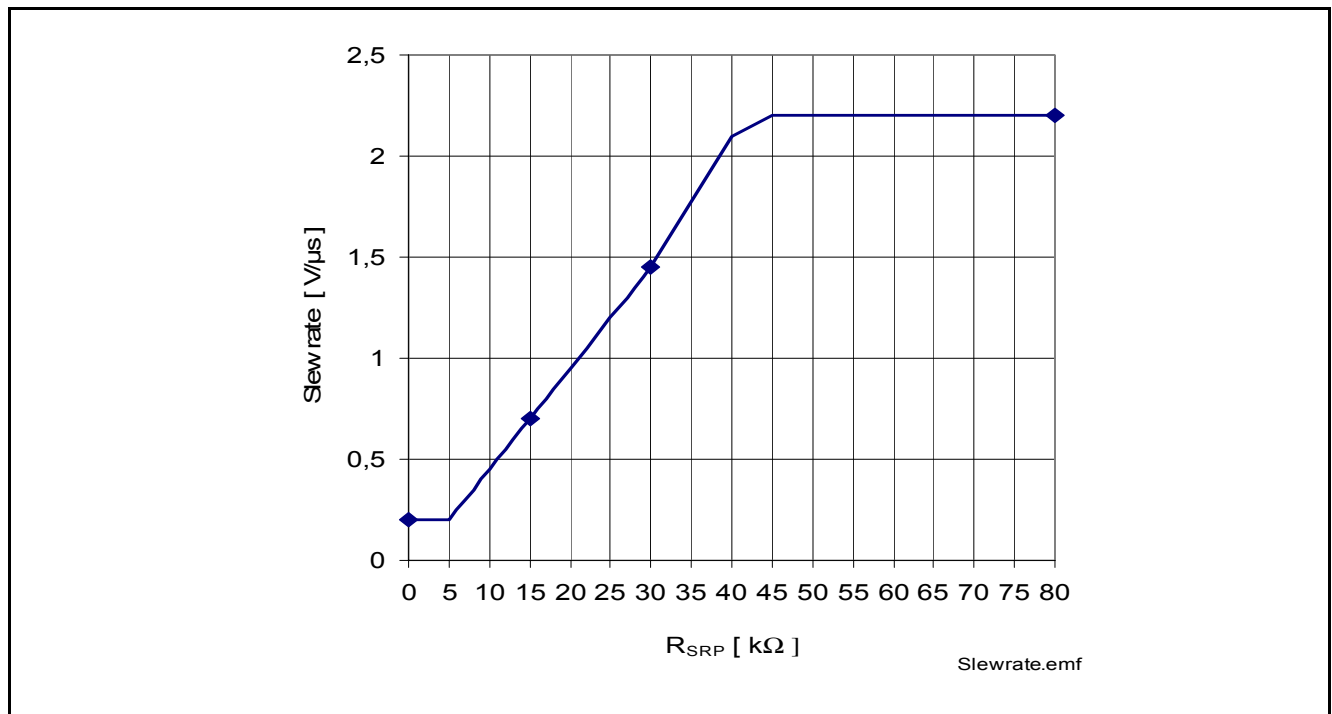

Figure 15 Typical relation between slew rate and resistor values used on  $R_{SRP}$  ( $V_{bat} = 13.5\text{V}$ )

## 8 Protection Functions

The device provides embedded protection functions against over temperature, over load and short circuit.

*Note: Integrated protection functions are designed to prevent IC destruction under fault conditions described in the data sheet. Fault conditions are considered as “outside” normal operation.*

### 8.1 Thermal Protection

The device is protected against over temperature resulting from overload and / or bad cooling conditions.

The BTS 3256D has a thermal restart function. When overheating occurs, the device switches off for the restart delay time  $t_{\text{restart}}$ . After this time the device restarts if the temperature is below threshold and the IN has logic high level. The fault feedback is activated during over temperature situation. See [Figure 16](#) for the restart behavior.

The diagram naming refers to [Figure 14](#).

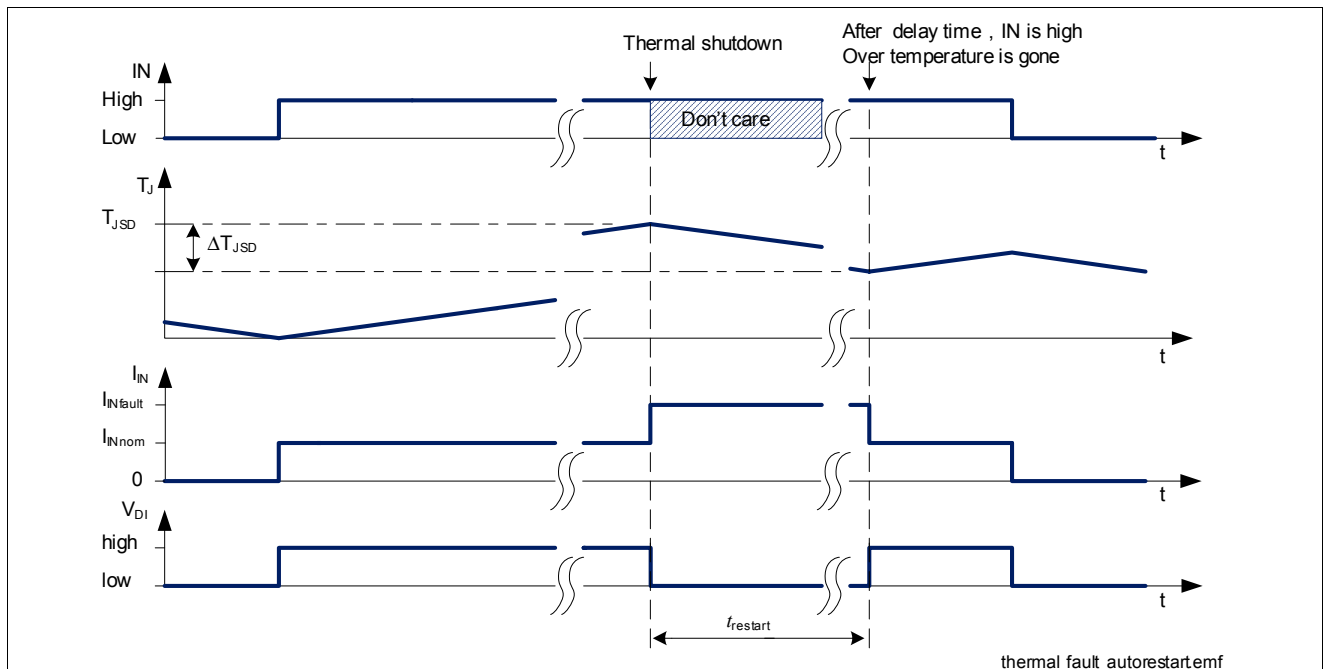

**Figure 16 Status Feedback via Input Current at Over temperature**

### 8.2 Over Voltage Protection

The BTS 3256D is equipped with a voltage clamp mechanism that keeps the Drain-Source voltage  $V_D$  at a certain level. This stage is also used for inductive clamping.

See [“Inductive Output Clamp” on Page 14](#) for details.



### 8.3 Short Circuit Protection

The condition short circuit is an overload condition of the device.

In a short circuit condition, the resulting  $dl / dt$  is a function of the short circuit resistance. The BTS3256D incorporates 2 shut down strategies for maximum robustness in the presence of short circuits:

- immediate shut down in the case of low ohmic shorts by power detection exceeding  $P_{max}$
- over temperature shut down in the case of an overload condition

The additional feature of this device is a limitation of the load current to  $I_{lim}$  for a maximum time of  $t_{lim}$ .

If the condition is normalized in a shorter time than  $t_{lim}$ , the device stays on, if not the device switch off for  $t_{restart}$  and tries to restart in case the IN pin is still high.

From first switch off the fault feedback will be activated during  $t_{restart}$  and continues until the IN pin goes low or normal condition is reached.

**Figure 18** shows the behavior mentioned above. In this example first a shorted load occurs which causes the device to limit the current. The device stays on, because the load current returns to normal condition before  $t_{restart}$ . In the second switch on, the short circuit is permanent and the device switches OFF after maximum limiting time, stays OFF for the blanking time regardless of the input pin condition and then stays OFF according to the IN pin low condition.

The definitions of voltages and currents are in respect to **Figure 14**. The behavior of  $V_{DI}$  also depends on  $R_{IN}$ .

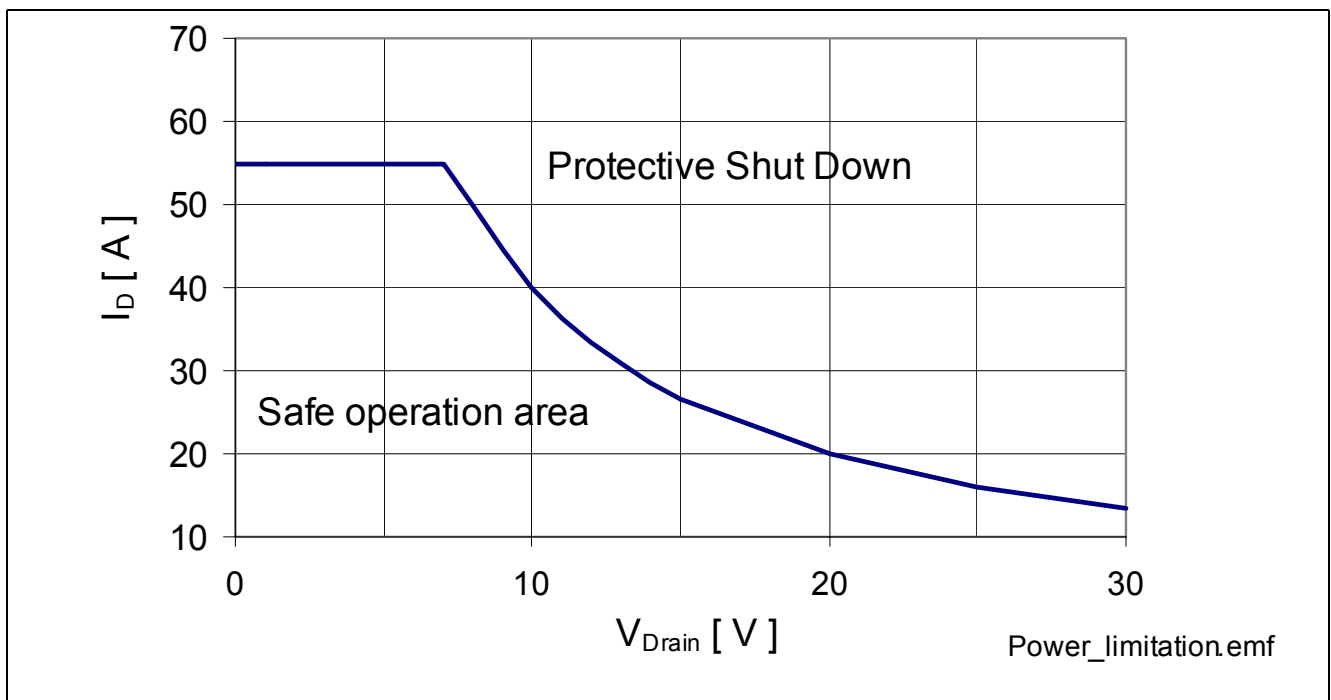

**Figure 17** Typical Power limitation behavior  $I_{DS} / V_{DS}$

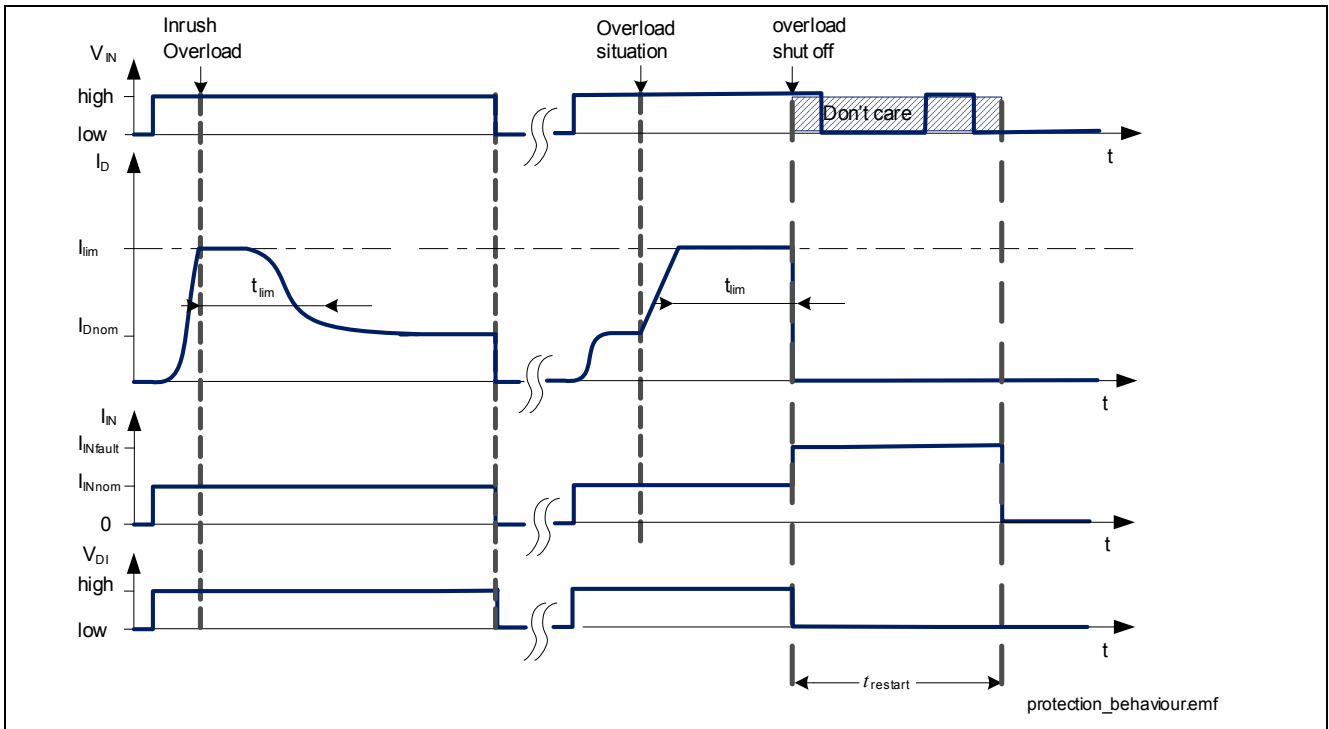

Figure 18 Short Circuit during On State, Typical Behavior for Ohmic Loads

The case when the device switches on into an existing short circuit - Short circuit type 1- is shown in Figure 17. The test setup for short circuit characterization is shown in Figure 19. The BTS 3256D is a low side switch. Therefore it can be assumed that the micro controller and device GND connection have a low impedance. All impedance in the short circuit path is merged in the short circuit resistance  $R_{SC}$  and short circuit inductance  $L_{SC}$ .

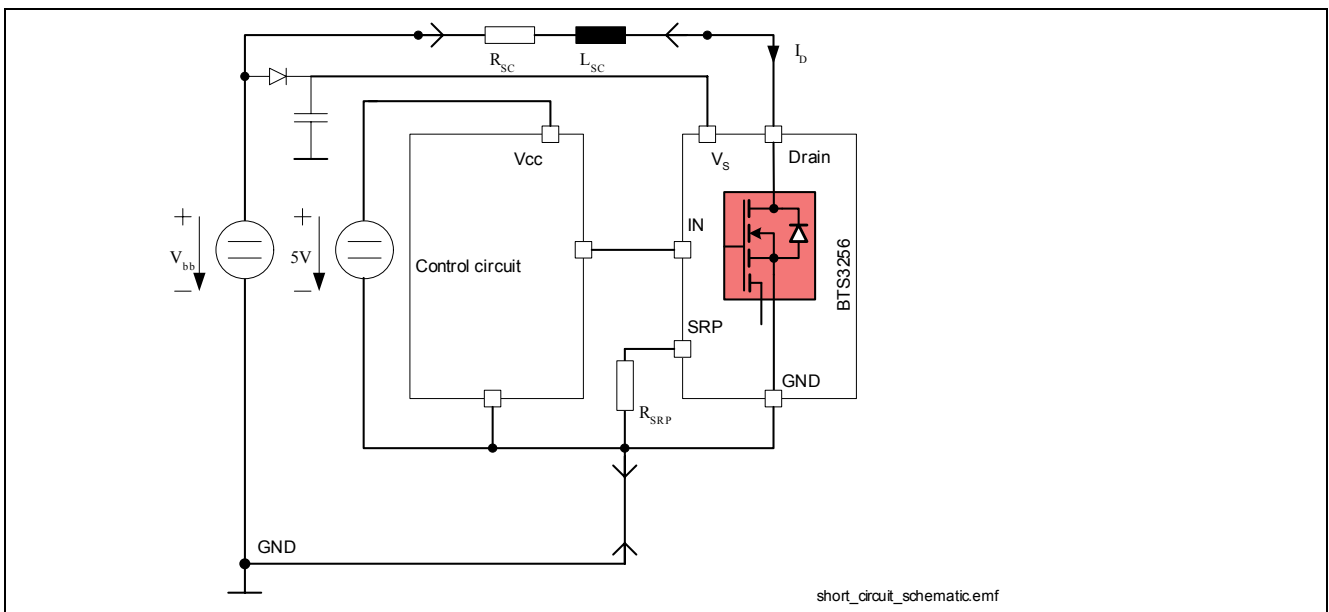

Figure 19 Test Setup for Short Circuit Characterization Test

## 8.4 Electrical Characteristics - Protection

$V_S = 5.5 \text{ V to } 30 \text{ V}$ ,  $T_j = -40 \text{ }^\circ\text{C to } +150 \text{ }^\circ\text{C}$

All voltages with respect to ground, positive current flowing into pin (unless otherwise specified)

| Pos.                            | Parameter  | Symbol                  | Limit Values |                   |      | Unit             | Conditions  |
|---------------------------------|--|-------------------------|--------------|-------------------|------|------------------|---|
|                                 |  |                         | Min.         | Typ.              | Max. |                  |   |
| <b>Thermal Protection</b>       |  |                         |              |                   |      |                  |   |
| 8.4.1                           | Thermal shut down junction temperature           | $T_{\text{JSD}}$        | 150          | 175 <sup>1)</sup> | –    | $^\circ\text{C}$ | –   |
| 8.4.2                           | Thermal hysteresis                               | $\Delta T_{\text{JSD}}$ | –            | 10                | –    | K                | 1)  |
| <b>Over Voltage Protection</b>  |  |                         |              |                   |      |                  |   |
| 8.4.3                           | Drain source clamp voltage                       | $V_{\text{D(AZ)}}$      | 40           | 44                | –    | V                | $I_{\text{D}} = 10 \text{ mA};$<br>$V_{\text{S}} = 0.0 \text{ V};$<br>$V_{\text{IN}} = 0.0 \text{ V}$ |
|                                 |  |                         | –            | 45                | 49   | V                | $I_{\text{D}} = 8 \text{ A};$<br>$V_{\text{S}} = 0.0 \text{ V};$<br>$V_{\text{IN}} = 0.0 \text{ V}$   |
| <b>Short Circuit Protection</b> |  |                         |              |                   |      |                  |   |
| 8.4.4                           | current limitation level                         | $I_{\text{D(lim)}}$     | 42           | 55                | 72   | A                | ohmic load  |
| 8.4.5                           | max. power switch OFF threshold                  | $P_{\text{max}}$        | 300          | 400               | 650  | W                | –   |
| 8.4.6                           | max. time for current limitation before shut OFF | $t_{\text{lim}}$        | 3.5          | 5                 | 6.5  | ms               | 2)<br>resistive load  |
| 8.4.7                           | restart delay time                               | $t_{\text{restart}}$    | 50           | 70                | 100  | ms               | –   |

1) Not subject to production test, specified by design.

2) In case of inductive loads the device needs to increase the VDS voltage during current limitation. This can trigger the over Power protection switch off earlier as  $t_{\text{lim}}$ .

## 9 Application Information

Note: The following information is given as a hint for the implementation of the device only and shall not be regarded as a description or warranty of a certain functionality, condition or quality of the device.

### 9.1 Dimensioning of serial Resistor at IN pin

In order to use the digital feedback function of the device, there must be a serial resistor used between the IN pin and the driver (micro controller).

To calculate this serial resistor on the input pin, three device conditions and of course the driver (micro controller) abilities need to be taken into account.

Figure 20 shows the circuit used for reading out the digital status.

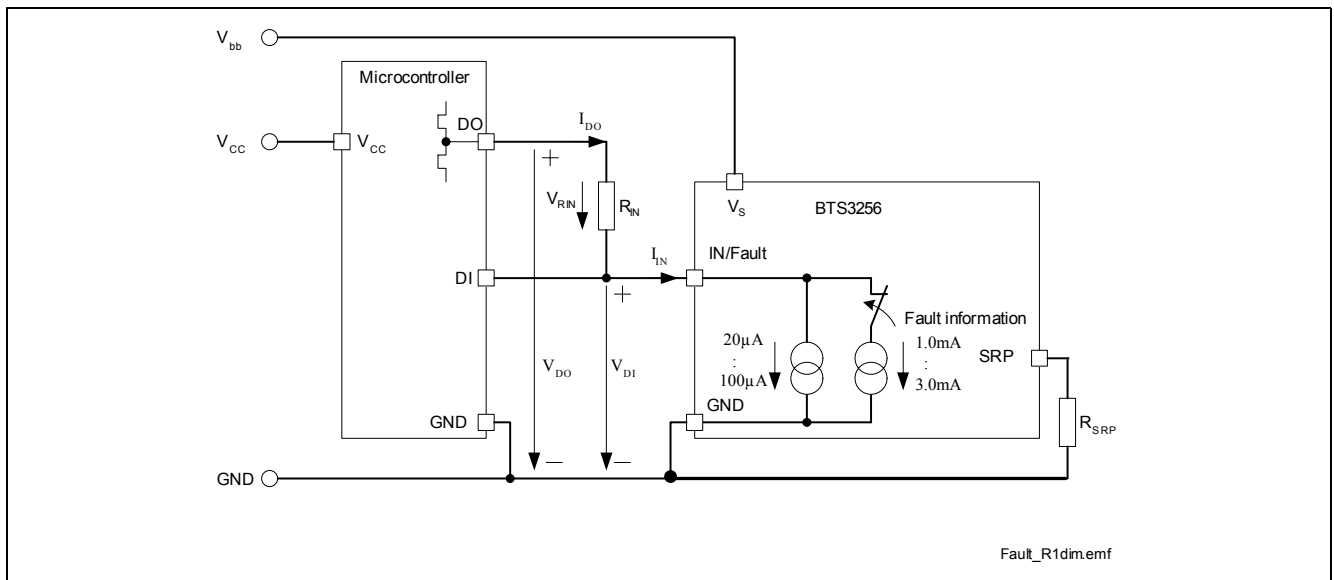

Figure 20 Circuitry to readout fault information

Note: This is a very simplified example of an application circuit. The function must be verified in the real application.

Conditions to be met by the circuitry:

During normal operation  $V_{IN}$  must be higher than  $V_{INH,min}$  to switch ON.

During fault condition the max. capability of the driver (micro controller) must not be exceeded and the logic low level at DI must be ensured by a voltage drop over the serial resistor  $R_{IN}$  while the device fault current is flowing.

Conditions in formulas:

- $\mu C_{output\ current,min} > \mu C_{HIGH,max} / R_{IN} > I_{INFault\_min}$   
with  $\mu C_{output\ current,min}$  referring to the  $\mu C$  maximum output current capability  
with  $\mu C_{HIGH,max}$  referring to the maximal high output voltage of the  $\mu C$  driving stage  
This condition is valid during status feedback operation mode
- $V_{IN} = \mu C_{HIGH,min} - (R_{IN} * I_{IN,max}) > V_{INH,min}$   
with  $\mu C_{HIGH,min}$  referring to the minimal high output voltage of the  $\mu C$  driving stage  
This condition is valid during normal operation mode

- $\mu C_{\text{HIGH,max}} - (R_{\text{IN}} * I_{\text{IN-Fault,min}}) < \mu C(DI)_{\text{L,max}}$   
with  $\mu C(DI)_{\text{L,max}}$  referring to the maximum logic low voltage of the  $\mu C$  input stage  
The maximum current is either defined by the BTS 3256D or the  $\mu C$  driving stage  
This condition is valid during status feedback operation mode

Out of this conditions the minimum and maximum resistor values can be calculated.

For a typical 5V micro controller with output current capability in the 3 mA range,  
a resistor range from 7.5 k $\Omega$  down to 4.5 k $\Omega$  can be used.

For a typical 3.3V micro controller a range from 4.6 k $\Omega$  to 2.5 k $\Omega$  is suitable.

## 9.2 Further Application Information

- For further information you may contact <http://www.infineon.com/hitfet>

10 Package Outlines

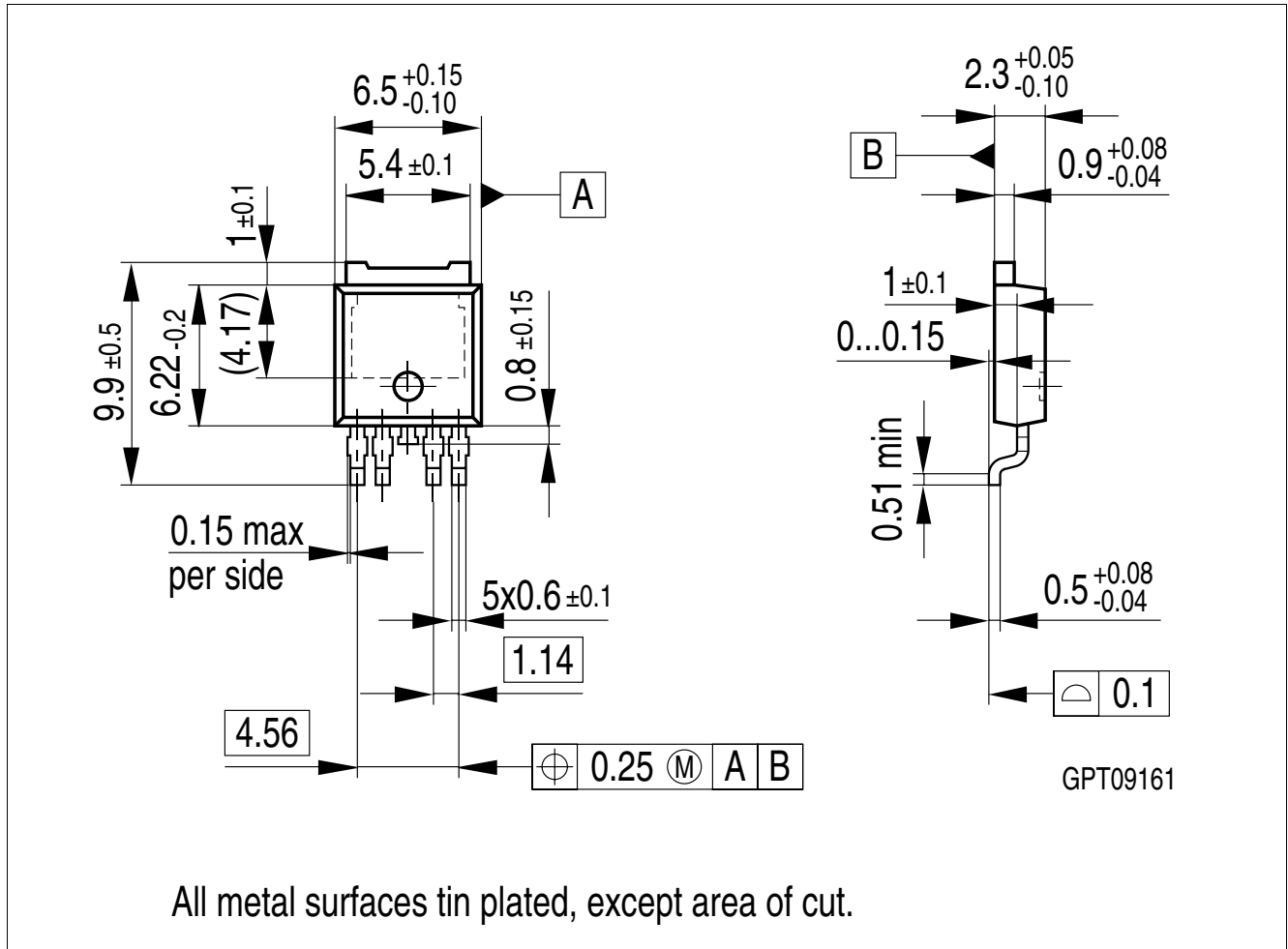

Figure 21 PG-TO-252-5-11 (Plastic Green Thin Outline Package)

Green Product (RoHS compliant)

To meet the world-wide customer requirements for environmentally friendly products and to be compliant with government regulations the device is available as a green product. Green products are RoHS-Compliant (i.e Pb-free finish on leads and suitable for Pb-free soldering according to IPC/JEDEC J-STD-020).

You can find all of our packages, sorts of packing and others in our Infineon Internet Page "Products": <http://www.infineon.com/products>.

Dimensions in mm

## 11 Revision History

| Version  | Date       | Changes            |
|----------|------------|--------------------|
| Rev. 1.0 | 2009-05-05 | released Datasheet |
|          |            |                    |
|          |            |                    |



**Edition 2009-05-05**

**Published by  
Infineon Technologies AG  
81726 Munich, Germany**

**© Infineon Technologies AG 2009.  
All Rights Reserved.**

### **Legal Disclaimer**

The information given in this document shall in no event be regarded as a guarantee of conditions or characteristics ("Beschaffenhheitsgarantie"). With respect to any examples or hints given herein, any typical values stated herein and/or any information regarding the application of the device, Infineon Technologies hereby disclaims any and all warranties and liabilities of any kind, including without limitation warranties of non-infringement of intellectual property rights of any third party.

### **Information**

For further information on technology, delivery terms and conditions and prices please contact your nearest Infineon Technologies Office ([www.infineon.com](http://www.infineon.com)).

### **Warnings**

Due to technical requirements components may contain dangerous substances. For information on the types in question please contact your nearest Infineon Technologies Office.

Infineon Technologies Components may only be used in life-support devices or systems with the express written approval of Infineon Technologies, if a failure of such components can reasonably be expected to cause the failure of that life-support device or system, or to affect the safety or effectiveness of that device or system. Life support devices or systems are intended to be implanted in the human body, or to support and/or maintain and sustain and/or protect human life. If they fail, it is reasonable to assume that the health of the user or other persons may be endangered.