

Smart High-Side Power Switch



Features

- Overload protection
 - Current limitation
 - Short circuit protection
 - Thermal shutdown
 - Overvoltage protection
 - Fast demagnetization of inductive loads
 - Reverse battery protection¹⁾
 - Open drain diagnostic output
 - Open load detection in OFF-state
 - CMOS compatible input
 - Loss of ground and loss of V_{bb} protection
 - **Electrostatic discharge (ESD)** protection
-
- Green Product (RoHS compliant)
 - AEC Qualified

Product Summary

Overvoltage protection	$V_{bb(AZ)}$	65	V
Operating voltage	$V_{bb(on)}$	5.8 ... 58	V
On-state resistance	R_{ON}	250	m Ω
Load current (ISO)	$I_{L(ISO)}$	1.7	A



Application

- μ C compatible power switch with diagnostic feedback for 12 V and 24 V DC grounded loads
- Most suitable for inductive loads
- Replaces electromechanical relays, fuses and discrete circuits

General Description

N channel vertical power FET with charge pump, ground referenced CMOS compatible input and diagnostic feedback, monolithically integrated in Smart SIPMOS® technology. Providing embedded protective functions.

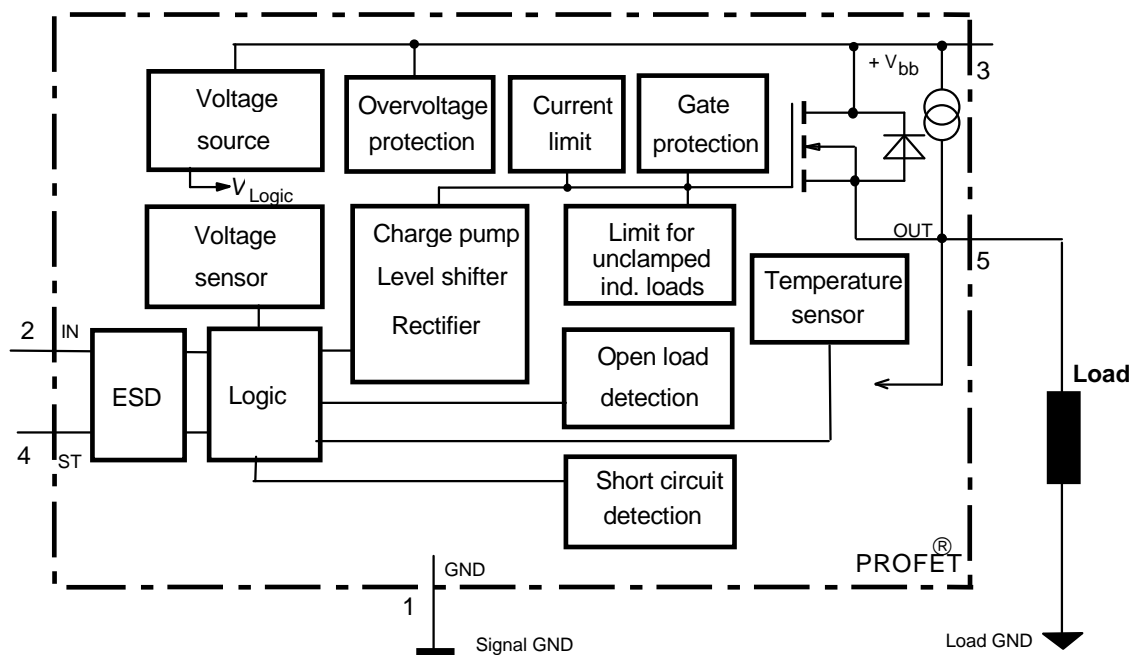

¹⁾ With external current limit (e.g. resistor $R_{GND}=150 \Omega$) in GND connection, resistor in series with ST connection, reverse load current limited by connected load.

Pin	Symbol		Function
1	GND	-	Logic ground
2	IN	I	Input, activates the power switch in case of logical high signal
3	V _{bb}	+	Positive power supply voltage, the tab is shorted to this pin
4	ST	S	Diagnostic feedback
5	OUT (Load, L)	O	Output to the load

Maximum Ratings at $T_j = 25\text{ °C}$ unless otherwise specified

Parameter	Symbol	Values	Unit
Supply voltage (overvoltage protection see page 3)	V_{bb}	65	V
Supply voltage for short circuit protection ²⁾ $T_{j\text{ start}} = -40 \dots +150\text{ °C}$	V_{bb}	40	V
Load current (Short circuit current, see page 4)	I_L	self-limited	A
Operating temperature range	T_j	-40 ... +150	°C
Storage temperature range	T_{stg}	-55 ... +150	
Power dissipation (DC), $T_C \leq 25\text{ °C}$	P_{tot}	50	W
Electrostatic discharge capability (ESD) (Human Body Model)	IN, ST: V_{ESD} all other pins:	1.0 tbd (>1.0)	kV
Input voltage (DC)	V_{IN}	-0.5 ... +36	V
Current through input pin (DC)	I_{IN}	± 2.0	mA
Current through status pin (DC)	I_{ST}	± 5.0	

see internal circuit diagrams page 5

Thermal Characteristics

Parameter and Conditions	Symbol	Values			Unit
		min	typ	max	
Thermal resistance	chip - case: R_{thJC}	--	--	2.5	K/W
	junction - ambient (free air): R_{thJA}	--	--	75	

²⁾ Status fault signal in case of short to GND. Internal thermal shutdown after several milliseconds. External shutdown in response to the status fault signal in less than about 1 ms necessary, if the device is used with higher V_{bb} .

Electrical Characteristics

Parameter and Conditions at $T_j = 25\text{ °C}$, $V_{bb} = 12\text{ V}$ unless otherwise specified	Symbol	Values			Unit
		min	typ	max	

Load Switching Capabilities and Characteristics

On-state resistance (pin 3 to 5) $I_L = 2\text{ A}$, $V_{bb} = 24\text{ V}$	$T_j = 25\text{ °C}$: $T_j = 150\text{ °C}$: R_{ON}	--	220 390	250 500	mΩ
Nominal load current, ISO Norm (pin 3 to 5) $V_{ON} = 0.5\text{ V}$, $T_C = 85\text{ °C}$	$I_{L(ISO)}$	1.4	1.7	--	A
Output current (pin 5) while GND disconnected or GND pulled up, $V_{bb} = 32\text{ V}$, $V_{IN} = 0$, see diagram page 6	$I_{L(GNDhigh)}$	--	--	1.1	mA
Turn-on time to 90% V_{OUT} : Turn-off time to 10% V_{OUT} : $R_L = 12\text{ Ω}$, $V_{bb} = 20\text{ V}$, $T_j = -40...+150\text{ °C}$	t_{on} t_{off}	15 20	-- --	80 70	μs
Slew rate on, 10 to 30% V_{OUT} , $R_L = 12\text{ Ω}$, $V_{bb} = 20\text{ V}$, $T_j = -40...+150\text{ °C}$	dV/dt_{on}	--	--	6	V/μs
Slew rate off, 10 to 30% V_{OUT} , $R_L = 12\text{ Ω}$, $V_{bb} = 20\text{ V}$, $T_j = -40...+150\text{ °C}$	$-dV/dt_{off}$	--	--	7	V/μs

Operating Parameters

Operating voltage ³⁾	$T_j = -40...+150\text{ °C}$: $V_{bb(on)}$	5.8	--	58	V
Undervoltage shutdown	$T_j = -40...+150\text{ °C}$: $V_{bb(under)}$	2.7	--	4.7	V
Undervoltage restart	$T_j = -40...+150\text{ °C}$: $V_{bb(u\text{ rst})}$	--	--	4.9	V
Undervoltage restart of charge pump see diagram page 10	$T_j = -40...+150\text{ °C}$: $V_{bb(ucp)}$	--	5.6	7.5	V
Undervoltage hysteresis $\Delta V_{bb(under)} = V_{bb(u\text{ rst})} - V_{bb(under)}$	$\Delta V_{bb(under)}$	--	0.4	--	V
Overshoot protection ⁴⁾ $I_{bb} = 40\text{ mA}$	$T_j = -40...+150\text{ °C}$: $V_{bb(AZ)}$	65	70	--	V
Standby current (pin 3), $V_{IN} = 0$	$T_j = -40...+150\text{ °C}$: $I_{bb(off)}$	--	10	50	μA
Operating current (Pin 1) ⁵⁾ , $V_{IN} = 5\text{ V}$	I_{GND}	--	2.2	--	mA

³⁾ At supply voltage increase up to $V_{bb} = 5.6\text{ V}$ typ without charge pump, $V_{OUT} \approx V_{bb} - 2\text{ V}$

⁴⁾ See also $V_{ON(CL)}$ in table of protection functions and circuit diagram page 6.



⁵⁾ Add I_{ST} , if $I_{ST} > 0$, add I_{IN} , if $V_{IN} > 5.5\text{ V}$

Parameter and Conditions at $T_j = 25\text{ °C}$, $V_{bb} = 12\text{ V}$ unless otherwise specified	Symbol	Values			Unit
		min	typ	max	
Protection Functions⁶⁾					
Initial peak short circuit current limit (pin 3 to 5)	$I_{L(SCp)}$				
$T_j = -40\text{ °C}$:		--	--	19	A
$T_j = 25\text{ °C}$:		--	10	--	
$T_j = +150\text{ °C}$:		4.0	--	--	
Output clamp (inductive load switch off) at $V_{OUT} = V_{bb} - V_{ON(CL)}$ $I_L = 1\text{ A}$, $T_j = -40..+150\text{ °C}$:	$V_{ON(CL)}$	59	--	75	V
Thermal overload trip temperature	T_{jt}	150	--	--	°C
Thermal hysteresis	ΔT_{jt}	--	10	--	K
Reverse battery (pin 3 to 1) ⁷⁾	$-V_{bb}$	--	--	32	V

Diagnostic Characteristics

Open load detection current (included in standby current $I_{bb(off)}$)	$I_{L(off)}$	--	6	--	μA
Open load detection voltage $T_j = -40..150\text{ °C}$:	$V_{OUT(OL)}$	2.4	3	4	V
Short circuit detection voltage (pin 3 to 5)	$V_{ON(SC)}$	--	2.5	--	V

Input and Status Feedback⁸⁾

Input resistance see circuit page 5	R_i	--	20	--	$\text{k}\Omega$
Input turn-on threshold voltage 	$V_{IN(T+)}$	1	--	2.5	V
Input turn-off threshold voltage 	$V_{IN(T-)}$	0.8	--	--	V
Input threshold hysteresis	$\Delta V_{IN(T)}$	--	0.5	--	V
Off state input current (pin 2), $V_{IN} = 0.4\text{ V}$	$I_{IN(off)}$	1	--	30	μA
On state input current (pin 2), $V_{IN} = 3.5\text{ V}$	$I_{IN(on)}$	10	25	70	μA
Delay time for status with open load after Input neg. slope (see diagram page 10)	$t_{d(ST\ OL3)}$	--	200	--	μs
Status output (open drain)					
Zener limit voltage $T_j = -40..+150\text{ °C}$, $I_{ST} = +1.6\text{ mA}$:	$V_{ST(high)}$	5.4	6.1	--	V
ST low voltage $T_j = -40..+150\text{ °C}$, $I_{ST} = +1.6\text{ mA}$:	$V_{ST(low)}$	--	--	0.4	

⁶⁾ Integrated protection functions are designed to prevent IC destruction under fault conditions described in the data sheet. Fault conditions are considered as "outside" normal operating range. Protection functions are not designed for continuous repetitive operation.

⁷⁾ Requires $150\ \Omega$ resistor in GND connection. The reverse load current through the intrinsic drain-source diode has to be limited by the connected load. Note that the power dissipation is higher compared to normal operating conditions due to the voltage drop across the intrinsic drain-source diode. The temperature protection is not active during reverse current operation! Input and Status currents have to be limited (see max. ratings page 2 and circuit page 6).

⁸⁾ If a ground resistor R_{GND} is used, add the voltage drop across this resistor.

Truth Table

	Input- level	Output level	Status BTS307
Normal operation	L H	L H	L H
Open load	L H	⁹⁾ H H	H H
Short circuit to GND	L H	L L	L L
Short circuit to V_{bb}	L H	H H	H H
Overtem- perature	L H	L L	L L
Under- voltage	L H	L L	L L
Overvoltage	no overvoltage shutdown, see normal operation		

L = "Low" Level X = don't care Z = high impedance, potential depends on external circuit
H = "High" Level Status signal after the time delay shown in the diagrams (see fig 5. page 10)

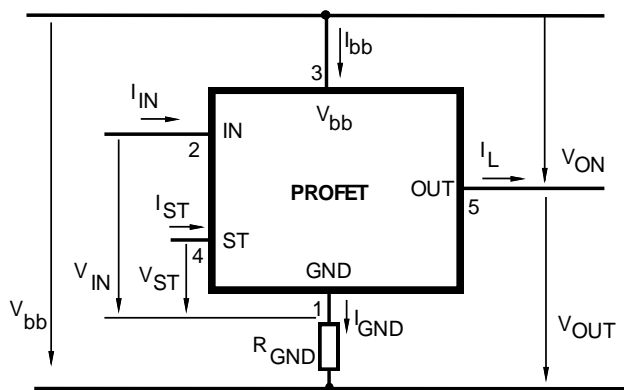
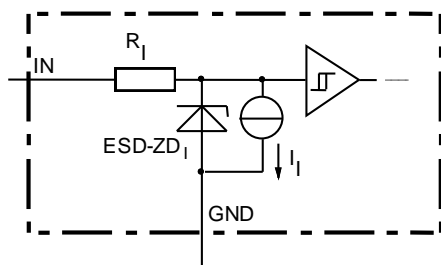
Terms

Input circuit (ESD protection)

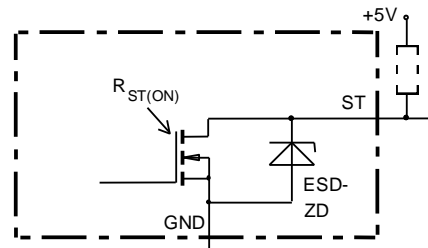
ESD zener diodes are not to be used as voltage clamp at DC conditions. Operation in this mode may result in a drift of the zener voltage (increase of up to 1 V).

Status output

ESD-Zener diode: 6.1 V typ., max 5 mA;
 $R_{ST(ON)} < 0 \Omega$ at 1.6 mA, ESD zener diodes are not to be used as voltage clamp at DC conditions. Operation in this mode may result in a drift of the zener voltage (increase of up to 1 V).

Short circuit detection

Fault Signal at ST-Pin: $V_{ON} > 2.5$ V typ, no switch off by the PROFET itself, external switch off recommended!

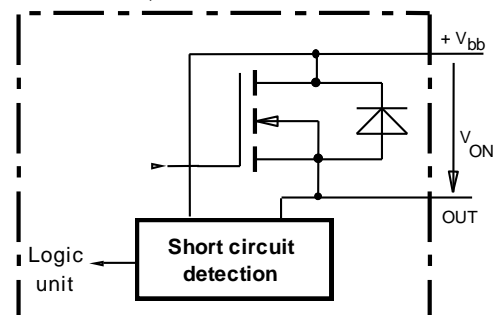

⁹⁾ Power Transistor off, high impedance, internal pull up current source for open load detection.

Inductive and overvoltage output clamp

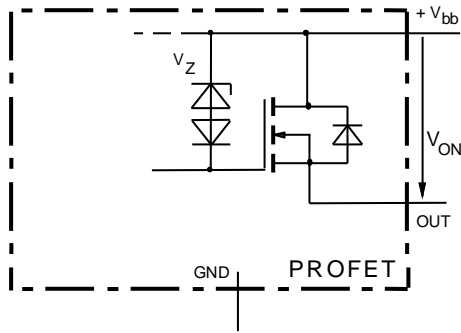

V_{ON} clamped to $-V$ typ.

Overvolt. and reverse batt. protection

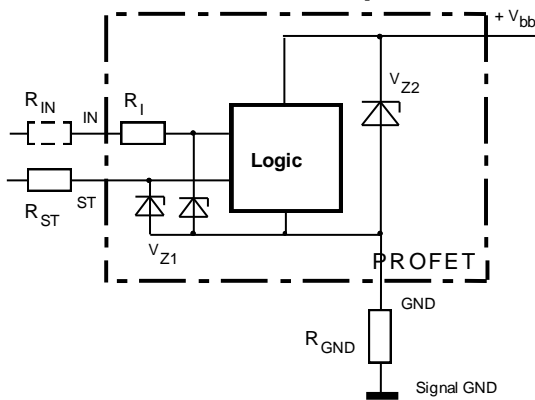

$V_{Z1} = 6.2 \text{ V typ.}$, $V_{Z2} = 70 \text{ V typ.}$, $R_{GND} = 150 \Omega$, $R_{ST} = 15 \text{ k}\Omega$, $R_I = 20 \text{ k}\Omega \text{ typ.}$

Open-load detection

OFF-state diagnostic condition: $V_{OUT} > 3 \text{ V typ.}$; IN low

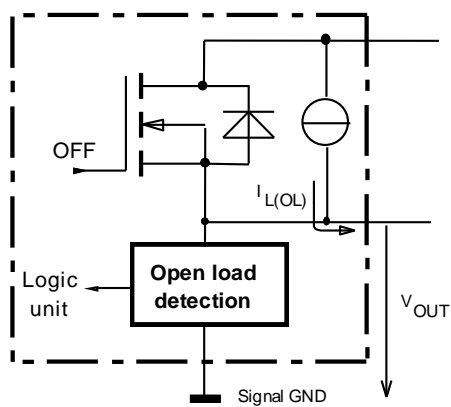

GND disconnect

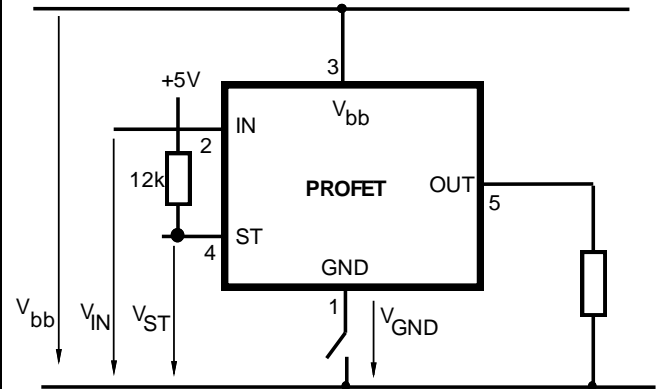

For $V_{bb}=24\text{V}$ and $V_{IN}=0\text{V}$: $V_{ST}>2.8\text{V}$ @ $I_{ST} \geq 0$ if pulled up as shown. Any kind of load. In case of Input=high is $V_{OUT} \approx V_{IN} - V_{IN(T+)}$.

GND disconnect with GND pull up

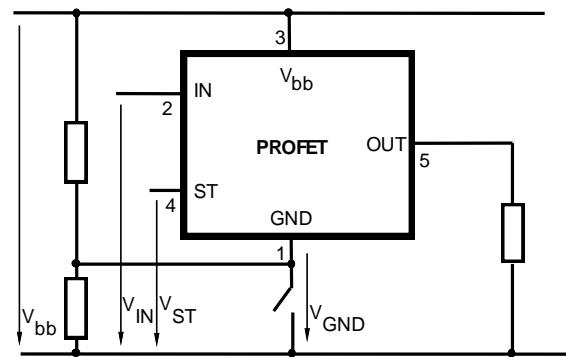

Any kind of load. If $V_{GND} > V_{IN} - V_{IN(T+)}$ device stays off. Due to $V_{GND} > 0$, no $V_{ST} = \text{low}$ signal available.

Vbb disconnect with energized inductive load

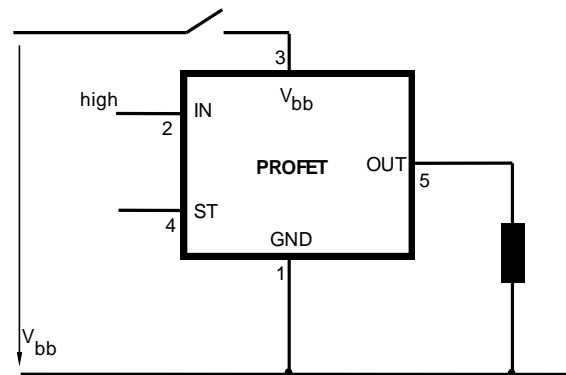

Normal load current can be handled by the PROFET itself.

V_{bb} disconnect with charged external inductive load

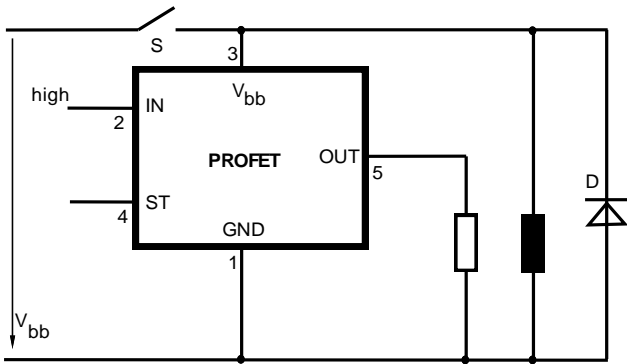

If other external inductive loads L are connected to the PROFET, additional elements like D are necessary.

Inductive Load switch-off energy dissipation

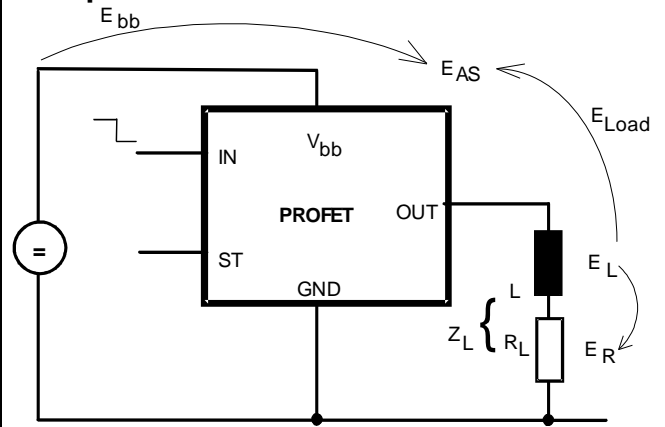

Energy stored in load inductance:

$$E_L = 1/2 \cdot L \cdot I_L^2$$

While demagnetizing load inductance, the energy dissipated in PROFET is

$$E_{AS} = E_{bb} + E_L - E_R = \int V_{ON(CL)} \cdot i_L(t) dt,$$

with an approximate solution for $R_L > 0 \Omega$:

$$E_{AS} = \frac{I_L \cdot L}{2 \cdot R_L} \cdot (V_{bb} + |V_{OUT(CL)}|) \cdot \ln \left(1 + \frac{I_L \cdot R_L}{|V_{OUT(CL)}|} \right)$$

Options Overview

all versions: High-side switch, Input protection, ESD protection and reverse battery protection with 150 Ω in GND connection, protection against loss of ground

Type	BTS	410D2	410E2	410G2	410H2	307	308
Logic version	D	E	G	H			
Overtemperature protection with hysteresis							
$T_j > 150\text{ °C}$, latch function ¹⁰⁾ ¹¹⁾	X				X		X
$T_j > 150\text{ °C}$, with auto-restart on cooling		X	X			X	
Short circuit to GND protection							
switches off when $V_{ON} > 3.5\text{ V}$ typ. and $V_{bb} > 8\text{ V}$ typ. ¹⁰⁾ (when first turned on after approx. 150 μs)					X		X
switches off when $V_{ON} > 8.5\text{ V}$ typ. ¹⁰⁾ (when first turned on after approx. 150 μs) Achieved through overtemperature protection	X	X		X		X	
Open load detection							
in OFF-state with sensing current 6 μA typ. in ON-state with sensing voltage drop across power transistor	X	X	X		X	X	X
Undervoltage shutdown with auto restart	X	X	X	X	X	X	X
Overvoltage shutdown with auto restart	X	X	X	X	X	-	X
Status feedback for							
overtemperature	X	X	X	X	X	X	X
short circuit to GND	X	X	-	X	X	X	X
short to V_{bb}	- ¹²⁾	- ¹²⁾	- ¹²⁾	X	X	X	X
open load	X	X	X	X	X	X	X
undervoltage	X	-	-	-	-	X	-
overvoltage	X	-	-	-	-	-	-
Status output type							
CMOS	X						
Open drain		X	X	X	X	X	X
Output negative voltage transient limit (fast inductive load switch off)							
to $V_{bb} - V_{ON(CL)}$	X	X	X	X	X	X	X
Load current limit							
high level (can handle loads with high inrush currents)	X	X					
low level (better protection of application)			X	X	X	X	X
Protection against loss of GND	X	X	X	X	X	X	X

¹⁰⁾ Latch except when $V_{bb} - V_{OUT} < V_{ON(SC)}$ after shutdown. In most cases $V_{OUT} = 0\text{ V}$ after shutdown ($V_{OUT} \neq 0\text{ V}$ only if forced externally). So the device remains latched unless $V_{bb} < V_{ON(SC)}$ (see page 4). No latch between turn on and $t_{d(SC)}$.

¹¹⁾ With latch function. Reset by a) Input low, b) Undervoltage, c) Overvoltage

¹²⁾ Low resistance short V_{bb} to output may be detected in ON-state by the no-load-detection

Timing diagrams

Figure 1a: V_{bb} turn on, :

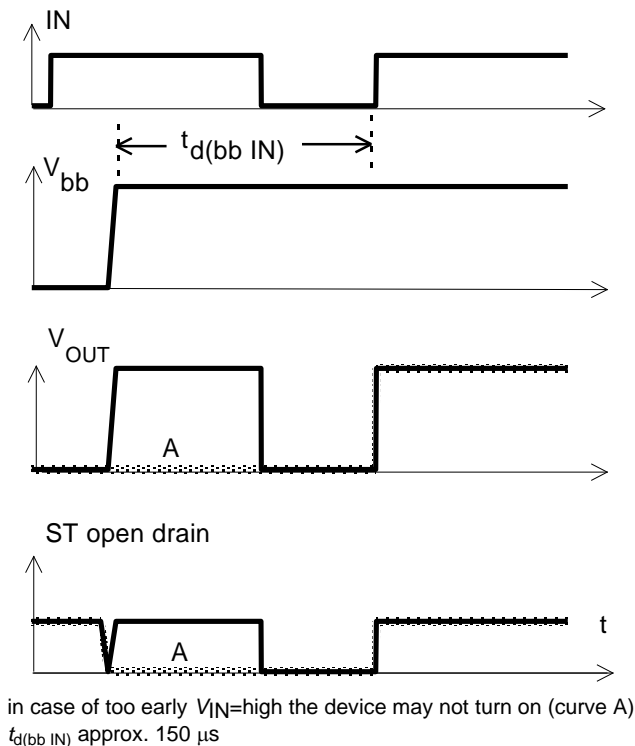

Figure 2a: Switching an inductive load,

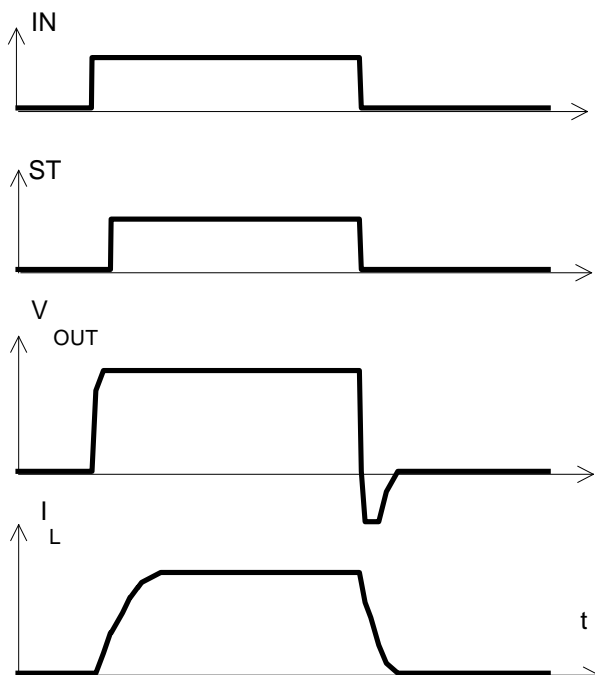
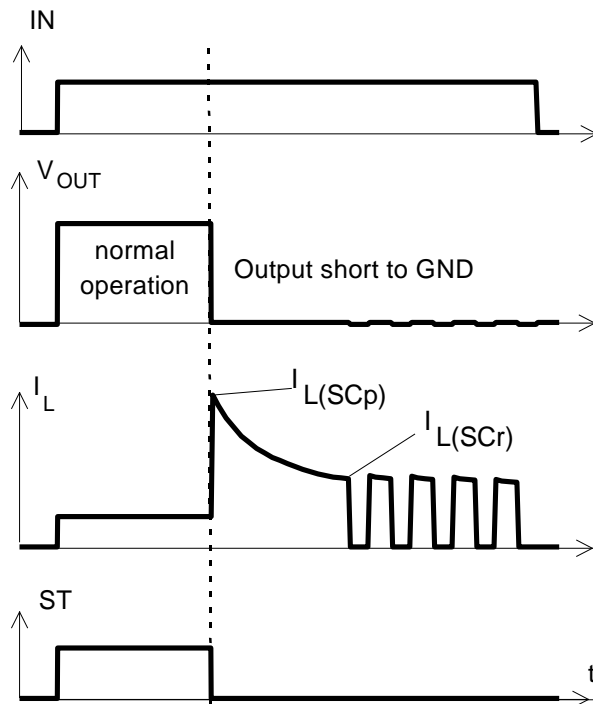

Figure 3a: Short circuit:
 shut down by overtemperature, reset by cooling



Heating up requires several milliseconds, depending on external conditions. External shutdown in response to status fault signal recommended.

Figure 4a: Overtemperature:
 Reset if $T_j < T_{jt}$

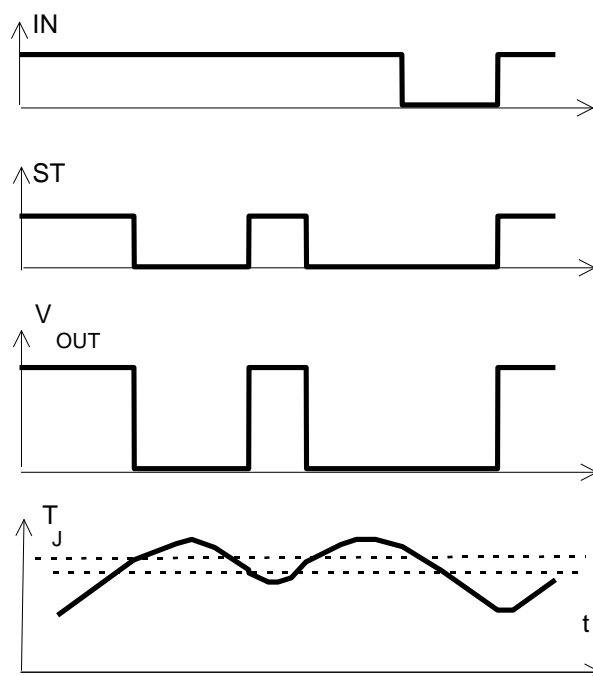
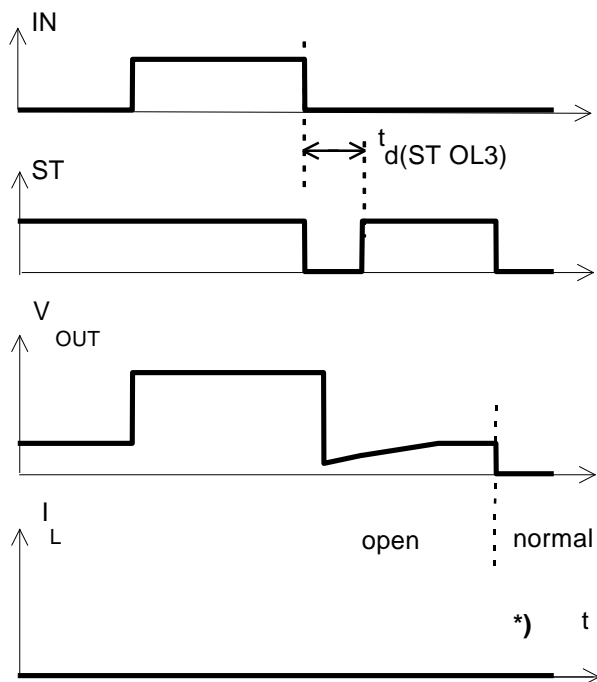
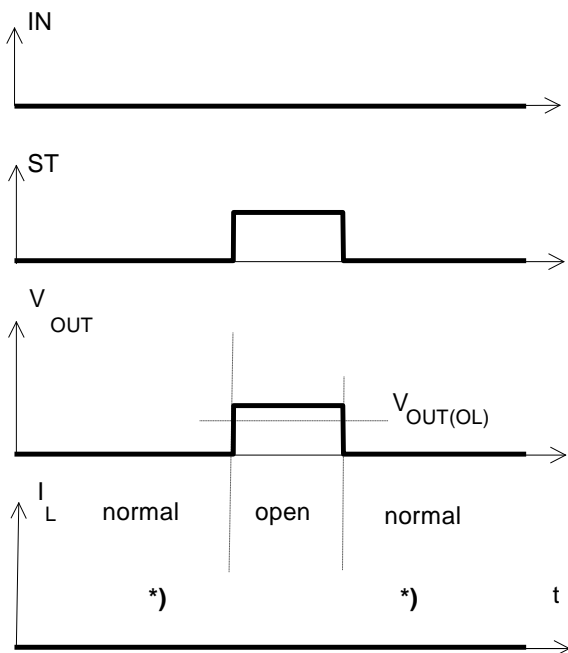

Figure 5a: Open load, : detection in OFF-state, turn on/off to open load



$t_{d(ST,OL3)}$ depends on external circuitry because of high impedance
 *) $I_L = 6 \mu A$ typ

Figure 5b: Open load, : detection in OFF-state, open load occurs in off-state



*) $I_L = 6 \mu A$ typ

Figure 6a: Undervoltage:

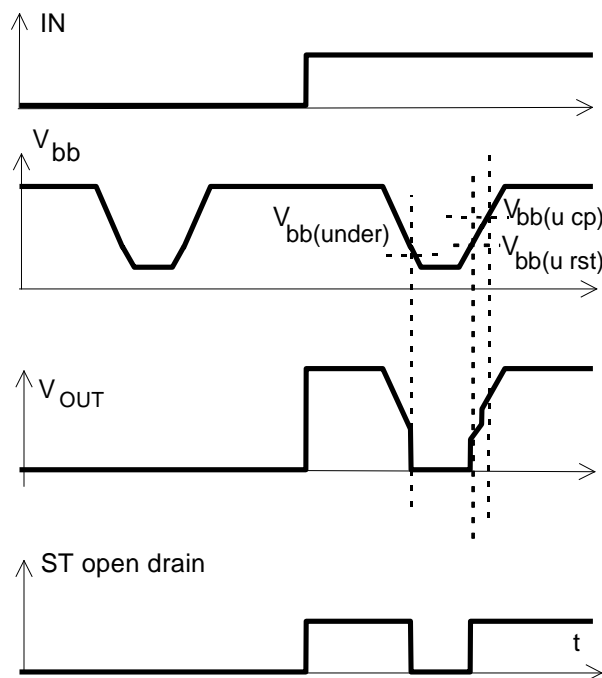

Figure 6b: Undervoltage restart of charge pump

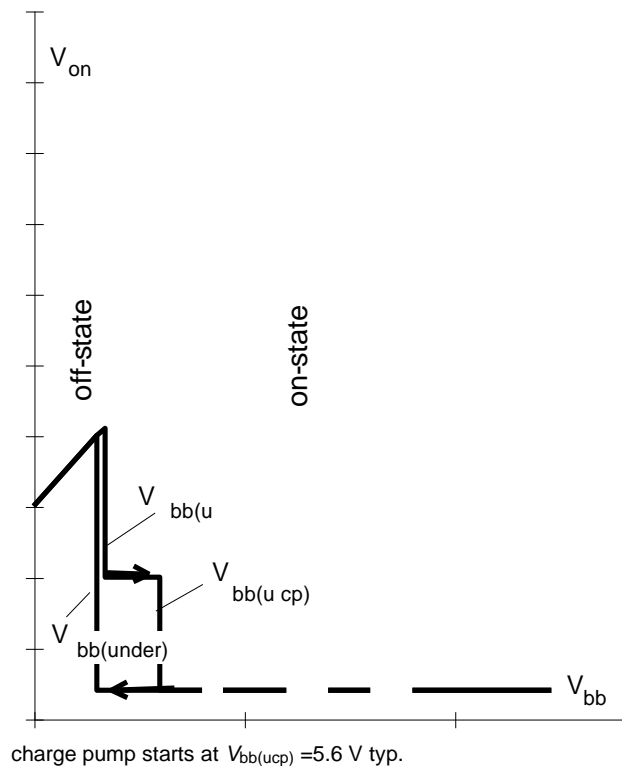
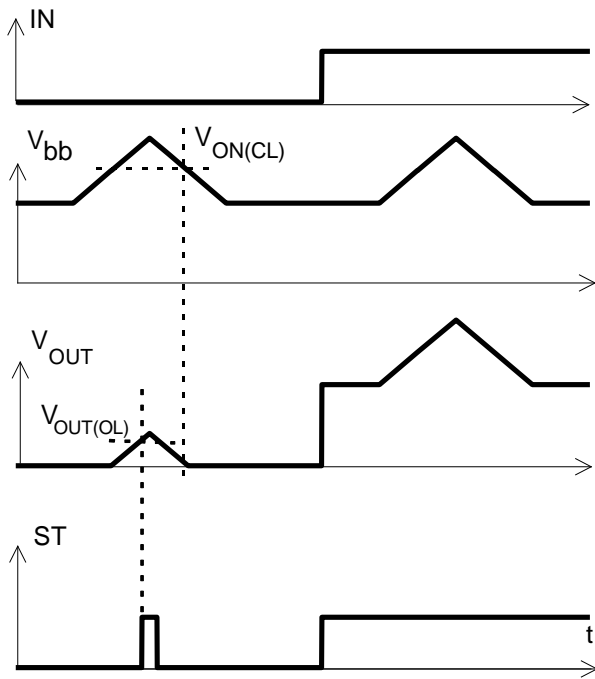

Figure 7a: Overvoltage, no shutdown:



Package and Ordering Code

All dimensions in mm

PG-TO263-5-2

Ordering code

BTS307 E3062A	SP001104812
---------------	-------------

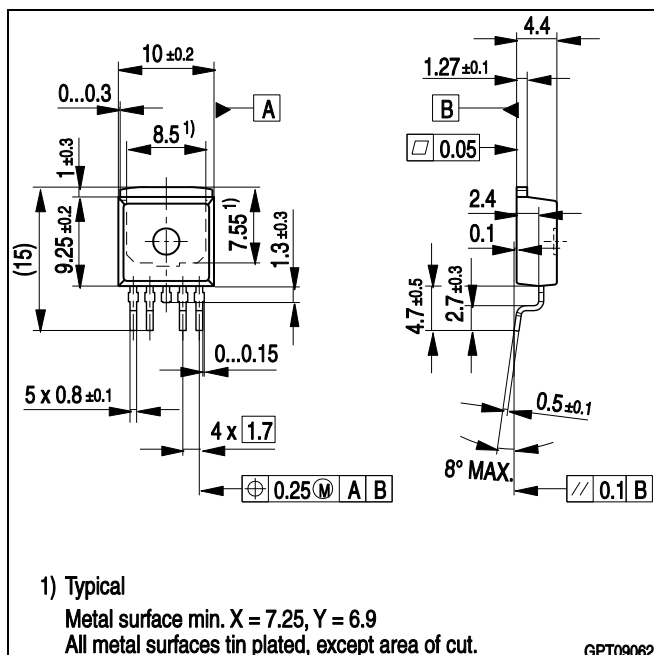

Published by
Infineon Technologies AG,
D-81726 München
© Infineon Technologies AG 201
All Rights Reserved.

Attention please!

The information herein is given to describe certain components and shall not be considered as a guarantee of characteristics.

Terms of delivery and rights to technical change reserved.

We hereby disclaim any and all warranties, including but not limited to warranties of non-infringement, regarding circuits, descriptions and charts stated herein.

Infineon Technologies is an approved CECC manufacturer.

Information

For further information on technology, delivery terms and conditions and prices please contact your nearest Infineon Technologies Office in Germany or our Infineon Technologies Representatives worldwide (see address list).

Warnings

Due to technical requirements components may contain dangerous substances. For information on the types in question please contact your nearest Infineon Technologies Office.

Infineon Technologies Components may only be used in life-support devices or systems with the express written approval of Infineon Technologies, if a failure of such components can reasonably be expected to cause the failure of that life-support device or system, or to affect the safety or effectiveness of that device or system. Life support devices or systems are intended to be implanted in the human body, or to support and/or maintain and sustain and/or protect human life. If they fail, it is reasonable to assume that the health of the user or other persons may be endangered.