

Highly Integrated Wireless Receiver Qi (WPC V1.1) Compliant Power Supply

Check for Samples: [bq51013B](#)

FEATURES

- **Integrated Wireless Power Supply Receiver Solution**
 - 93% Overall Peak AC-DC Efficiency
 - Full Synchronous Rectifier
 - WPC v1.1 Compliant Communication Control
 - Output Voltage Conditioning
 - Only IC Required Between RX coil and Output
- **WPC v1.1 Compliant (FOD Enabled) Highly Accurate Current Sense**
- **Dynamic Rectifier Control for Improved Load Transient Response**
- **Dynamic Efficiency Scaling for Optimized Performance Over wide Range of Output Power**
- **Adaptive Communication Limit for Robust Communication**
- **Supports 20-V Maximum Input**
- **Low-power Dissipative Rectifier Overvoltage Clamp ($V_{OVP} = 15V$)**
- **Thermal Shutdown**
- **Multifunction NTC and Control Pin for Temperature Monitoring, Charge Complete and Fault Host Control**
- **1.9 x 3mm DSBGA or 4.5 x 3.5mm QFN Package**

APPLICATIONS

- **WPC Compliant Receivers**
- **Cell Phones, Smart Phones**
- **Headsets**
- **Digital Cameras**
- **Portable Media Players**
- **Hand-held Devices**

DESCRIPTION

The bq5101xB is a family of advanced, flexible, secondary-side devices for wireless power transfer in portable applications. The bq5101xB devices provide the AC/DC power conversion and regulation while integrating the digital control required to comply with the Qi v1.1 communication protocol. Together with the bq50xxx primary-side controller, the bq5101xB enables a complete contact-less power transfer system for a wireless power supply solution. Global feedback is established from the secondary to the primary in order to control the power transfer process utilizing the Qi v1.1 protocol.

The bq5101xB devices integrate a low resistance synchronous rectifier, low-dropout regulator, digital control, and accurate voltage and current loops to ensure high efficiency and low power dissipation.

The bq5101xB also includes a digital controller that can calculate the amount of power received by the mobile device within the limits set by the WPC v1.1 standard. The controller will then communicate this information to the transmitter in order to allow the transmitter to determine if a foreign object is present within the magnetic interface and introduces a higher level of safety within magnetic field. This Foreign Object Detection (FOD) method is part of the new requirements under the WPC v1.1 specification.

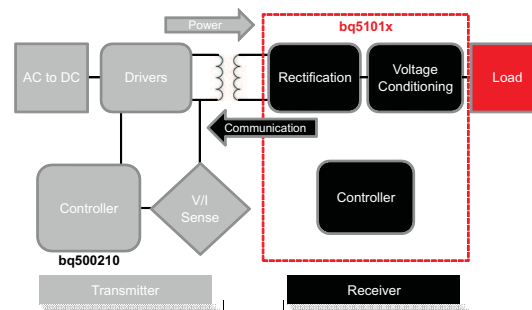

Figure 1. Wireless Power Consortium (WPC or Qi) Inductive Power System



Please be aware that an important notice concerning availability, standard warranty, and use in critical applications of Texas Instruments semiconductor products and disclaimers thereto appears at the end of this data sheet.

ORDERING INFORMATION

Part NO	Marking	Function	Package	Ordering Number (Tape and Reel)	Quantity
bq51013B	bq51013B	5V Regulated Power Supply	DSBGA-YFP	bq51013BYFPR	3000
				bq51013BYFPT	250
			QFN-RHL	bq51013BRHLR	3000
				bq51013BRHLT	250

AVAILABLE OPTIONS

Device	Function	WPC Version	V _{RECT-OVP}	V _{OUT-(REG)}	Over Current Shutdown	AD-OVP	Termination	Communication Current Limit ⁽¹⁾⁽²⁾
bq51013B	5V Power Supply	v1.1	15V	5V	Disabled	Disabled	Disabled	Adaptive + 1s Hold-Off
bq51010B ⁽³⁾	7V Power Supply	v1.1	15V	7V	Disabled	Disabled	Disabled	Adaptive + 1s Hold-Off

- (1) Enabled if EN2 is low and disabled if EN2 is high
(2) Communication current limit is disabled for 1 second at startup
(3) Product Preview

ABSOLUTE MAXIMUM RATINGS⁽¹⁾⁽²⁾

over operating free-air temperature range (unless otherwise noted)

		VALUES		UNITS
		MIN	MAX	
Input Voltage	AC1, AC2	-0.8	20	V
	RECT, COM1, COM2, OUT, $\overline{\text{CHG}}$, CLAMP1, CLAMP2	-0.3	20	V
	AD, $\overline{\text{AD-EN}}$	-0.3	30	V
	BOOT1, BOOT2	-0.3	26	V
	EN1, EN2, TERM, FOD, TS-CTRL, ILIM	-0.3	7	V
Input Current	AC1, AC2		2	A(RMS)
Output Current	OUT		1.5	A
Output Sink Current	$\overline{\text{CHG}}$		15	mA
	COM1, COM2		1	A
Junction temperature, T _J		-40	150	°C
Storage temperature, T _{STG}		-65	150	°C
ESD Rating (HBM) (100pF, 1.5KΩ)	All		2	kV
	CDM		500	V

- (1) All voltages are with respect to the VSS terminal, unless otherwise noted.
(2) Stresses beyond those listed under absolute maximum ratings may cause permanent damage to the device. These are stress ratings only, and functional operation of the device at these or any other conditions beyond those indicated under recommended operating conditions is not implied. Exposure to absolute-maximum-rated conditions for extended periods may affect device reliability.

THERMAL INFORMATION

THERMAL METRIC ⁽¹⁾		RHL	YFP	UNITS
		20 PINS	28 PINS	
θ_{JA}	Junction-to-ambient thermal resistance	37.7	58.9	°C/W
θ_{JCTop}	Junction-to-case (top) thermal resistance	35.5	0.2	
θ_{JB}	Junction-to-board thermal resistance	13.6	9.1	
Ψ_{JT}	Junction-to-top characterization parameter	0.5	1.4	
Ψ_{JB}	Junction-to-board characterization parameter	13.5	8.9	
θ_{JCbott}	Junction-to-case (bottom) thermal resistance	2.7	n/a	

(1) For more information about traditional and new thermal metrics, see the *IC Package Thermal Metrics* application report, [SPRA953](#).

RECOMMENDED OPERATING CONDITIONS

over operating free-air temperature range (unless otherwise noted)

			MIN	MAX	UNITS
V_{IN}	Input voltage range	RECT	4	10	V
I_{IN}	Input current	RECT		1.5	A
I_{OUT}	Output current	OUT		1.5	A
I_{AD-EN}	Sink current	$\overline{AD-EN}$		1	mA
I_{COMM}	COMM sink current	COMM		500	mA
T_J	Junction Temperature		0	125	°C

TYPICAL APPLICATION SCHEMATICS

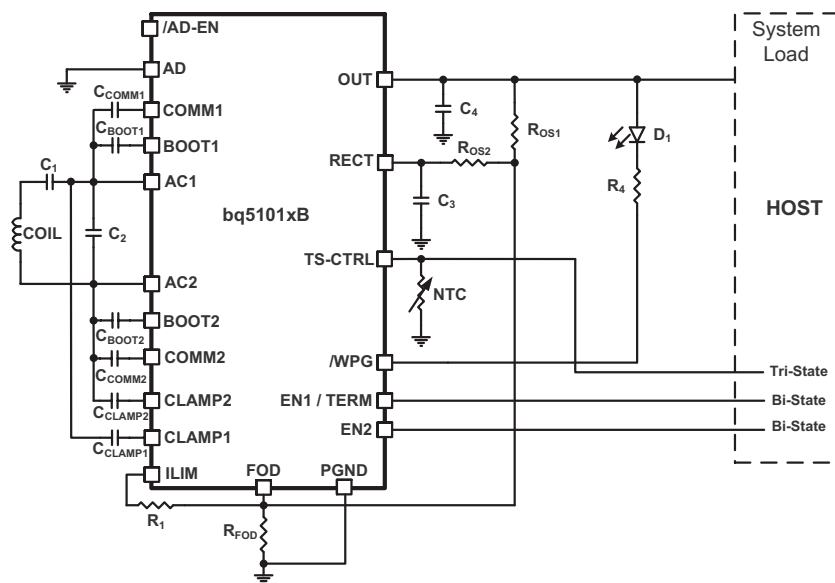

Figure 2. bq5101xB Used as a Wireless Power Receiver and Power Supply for System Loads
Only one of R_{OS1} or R_{OS2} needed

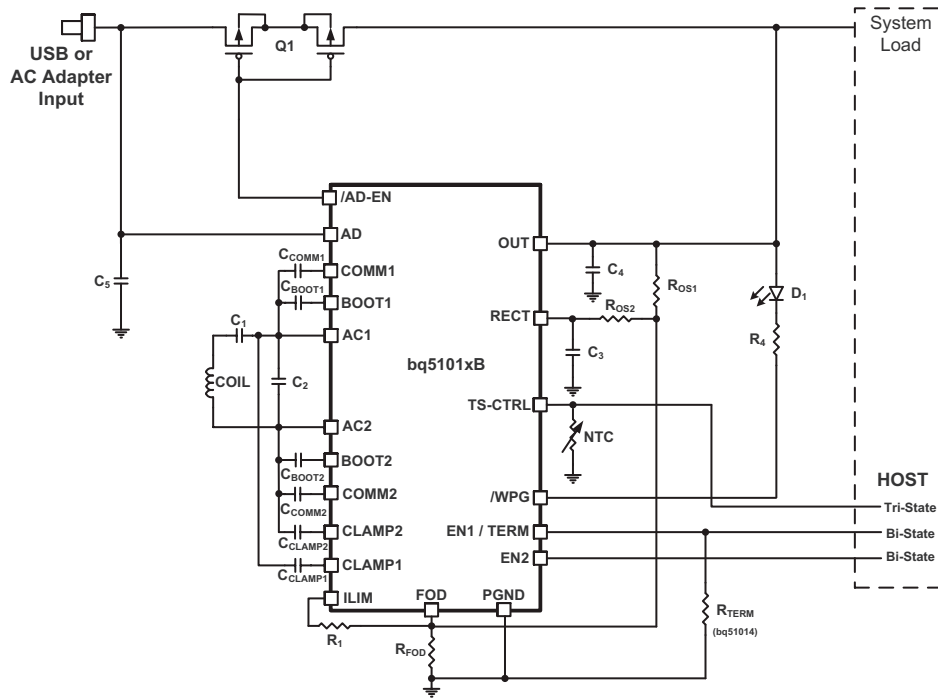

Figure 3. bq5101xB Used as a Wireless Power Receiver and Power Supply for System Loads With Adapter Power-Path Multiplexing – Only one of R_{OS1} or R_{OS2} Needed

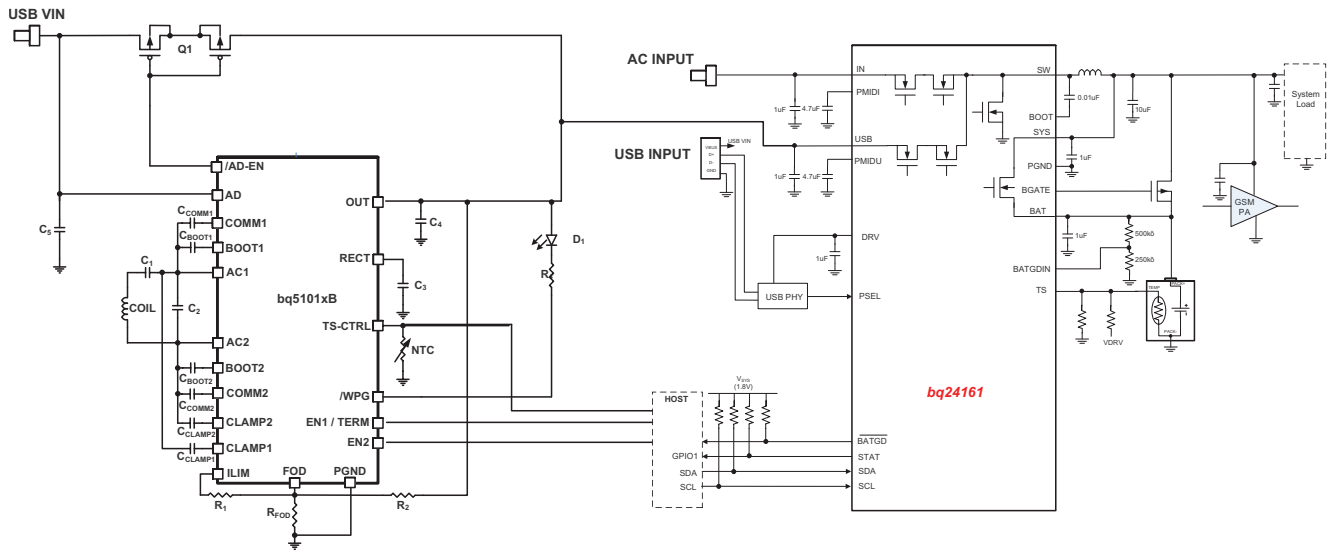

Figure 4. bq5101xB Used as a Wireless Power Supply with Adapter Multiplexing on a Two Input Charger

ELECTRICAL CHARACTERISTICS

over operating free-air temperature range, 0°C to 125°C (unless otherwise noted)

PARAMETER		TEST CONDITIONS	MIN	TYP	MAX	UNIT
UVLO	Undervoltage lock-out	$V_{RECT}: 0V \rightarrow 3V$	2.6	2.7	2.8	V
V_{HYS}	Hysteresis on UVLO	$V_{RECT}: 3V \rightarrow 2V$		250		mV
	Hysteresis on OVP	$V_{RECT}: 16V \rightarrow 5V$		150		mV
V_{RECT}	Input overvoltage threshold	$V_{RECT}: 5V \rightarrow 16V$	14.5	15	15.5	V
$V_{RECT-REG}$	Dynamic V_{RECT} Threshold 1	$I_{LOAD} < 0.1 \times I_{IMAX}$ (I_{LOAD} rising)		7.08		V
	Dynamic V_{RECT} Threshold 2	$0.1 \times I_{IMAX} < I_{LOAD} < 0.2 \times I_{IMAX}$ (I_{LOAD} rising)		6.28		
	Dynamic V_{RECT} Threshold 3	$0.2 \times I_{IMAX} < I_{LOAD} < 0.4 \times I_{IMAX}$ (I_{LOAD} rising)		5.53		
	Dynamic V_{RECT} Threshold 4	$I_{LOAD} > 0.4 \times I_{IMAX}$ (I_{LOAD} rising)		5.11		
		V_{RECT} TRACKING	IN CURRENT LIMIT VOLTAGE ABOVE V_{OUT}		$V_O+0.25$ 0	
I_{LOAD}	I_{LOAD} Hysteresis for dynamic V_{RECT} thresholds as a % of I_{LIM}	I_{LOAD} falling		4%		
$V_{RECT-DPM}$	Rectifier undervoltage protection, restricts I_{OUT} at $V_{RECT-DPM}$		3	3.1	3.2	V
$V_{RECT-REV}$	Rectifier reverse voltage protection at the output	$V_{RECT-REV} = V_{OUT} - V_{RECT}$, $V_{OUT} = 10V$		8	9	V
QUIESCENT CURRENT						
I_{RECT}	Active chip quiescent current consumption from RECT	$I_{LOAD} = 0$ mA, $0^\circ C \leq T_J \leq 85^\circ C$		8	10	mA
		$I_{LOAD} = 300$ mA, $0^\circ C \leq T_J \leq 85^\circ C$		2	3.0	mA
I_{OUT}	Quiescent current at the output when wireless power is disabled (Standby)	$V_{OUT} = 5$ V, $0^\circ C \leq T_J \leq 85^\circ C$		20	35	μ A
I_{LIM} SHORT CIRCUIT						
R_{LIM}	Highest value of I_{LIM} resistor considered a fault (short). Monitored for $I_{OUT} > 100$ mA	$R_{LIM}: 200\Omega \rightarrow 50\Omega$. I_{OUT} latches off, cycle power to reset			120	Ω
t_{DGL}	Deglint time transition from I_{LIM} short to I_{OUT} disable			1		ms
I_{LIM_SC}	$I_{LIM_SHORT_OK}$ enables the I_{LIM} short comparator when I_{OUT} is greater than this value	$I_{LOAD}: 0 \rightarrow 200$ mA	120	145	165	mA
	Hysteresis for $I_{LIM_SHORT_OK}$ comparator	$I_{LOAD}: 0 \rightarrow 200$ mA		30		mA
I_{OUT}	Maximum output current limit, C_L	Maximum I_{LOAD} that will be delivered for 1 ms when I_{LIM} is shorted			2.45	A
OUTPUT						
$V_{OUT-REG}$	Regulated output voltage	$I_{LOAD} = 1000$ mA	4.96	5.00	5.04	V
		$I_{LOAD} = 10$ mA	4.97	5.01	5.05	
K_{LIM}	Current programming factor for hardware protection	$R_{LIM} = K_{LIM} / I_{LIM}$, where I_{LIM} is the hardware current limit. $I_{OUT} = 1$ A	303	314	321	A Ω
K_{IMAX}	Current programming factor for the nominal operating current	$I_{IMAX} = K_{IMAX} / R_{LIM}$ where I_{IMAX} is the maximum normal operating current. $I_{OUT} = 1$ A		262		A Ω
I_{OUT}	Current limit programming range				1500	mA
I_{COMM}	Current limit during WPC communication	$I_{OUT} > 300$ mA		$I_{OUT} + 50$		mA
		$I_{OUT} < 300$ mA	343	378	425	mA
t_{HOLD}	Hold off time for the communication current limit during startup			1		s

ELECTRICAL CHARACTERISTICS (continued)

over operating free-air temperature range, 0°C to 125°C (unless otherwise noted)

PARAMETER		TEST CONDITIONS	MIN	TYP	MAX	UNIT
TS / CTRL						
V_{TS}	Internal TS Bias Voltage	$I_{TS-Bias} < 100 \mu A$ (periodically driven see $t_{TS-CTRL}$)	2	2.2	2.4	V
V_{COLD}	Rising threshold	$V_{TS}: 50\% \rightarrow 60\%$	56.5	58.7	60.8	% $V_{TS-Bias}$
	Falling hysteresis	$V_{TS}: 60\% \rightarrow 50\%$		2		
V_{HOT}	Falling threshold	$V_{TS}: 20\% \rightarrow 15\%$	18.5	19.6	20.7	
	Rising hysteresis	$V_{TS}: 15\% \rightarrow 20\%$		3		
V_{CTRL}	CTRL pin threshold for a high	$V_{TS/CTRL}: 50 \rightarrow 150mV$	80	100	130	mV
	CTRL pin threshold for a low	$V_{TS/CTRL}: 150 \rightarrow 50mV$	50	80	100	mV
$t_{TS-CTRL}$	Time $V_{TS-Bias}$ is active when TS measurements occur	Synchronous to the communication period		24		ms
t_{TS}	Deglintch time for all TS comparators			10		ms
R_{TS}	Pull-up resistor for the NTC network. Pulled up to the voltage bias		18	20	22	k Ω
THERMAL PROTECTION						
T_J	Thermal shutdown temperature			155		$^{\circ}C$
	Thermal shutdown hysteresis			20		$^{\circ}C$
OUTPUT LOGIC LEVELS ON \overline{WPG}						
V_{OL}	Open drain \overline{WPG} pin	$I_{SINK} = 5 \text{ mA}$			500	mV
I_{OFF}	\overline{WPG} leakage current when disabled	$V_{CHG} = 20 \text{ V}$			1	μA
COMM PIN						
$R_{DS(ON)}$	COM1 and COM2	$V_{RECT} = 2.6 \text{ V}$		1.5		Ω
f_{COMM}	Signaling frequency on COMM pin			2.00		Kb/s
I_{OFF}	Comm pin leakage current	$V_{COM1} = 20 \text{ V}, V_{COM2} = 20 \text{ V}$			1	μA
CLAMP PIN						
$R_{DS(ON)}$	Clamp1 and Clamp2			0.8		Ω
ADAPTER ENABLE						
V_{AD-EN}	V_{AD} Rising threshold voltage. EN-UVLO	$V_{AD} 0 \rightarrow 5 \text{ V}$	3.5	3.6	3.8	V
	V_{AD-EN} hysteresis, EN-HYS	$V_{AD} 5 \rightarrow 0 \text{ V}$		400		mV
I_{AD}	Input leakage current	$V_{RECT} = 0V, V_{AD} = 5V$			60	μA
R_{AD}	Pull-up resistance from $\overline{AD-EN}$ to OUT when adapter mode is disabled and $V_{OUT} > V_{AD}$, EN-OUT	$V_{AD} = 0, V_{OUT} = 5$		200	350	Ω
V_{AD}	Voltage difference between V_{AD} and V_{AD-EN} when adapter mode is enabled, EN-ON	$V_{AD} = 5 \text{ V}, 0^{\circ}C \leq T_J \leq 85^{\circ}C$	3	4.5	5	V

ELECTRICAL CHARACTERISTICS (continued)

over operating free-air temperature range, 0°C to 125°C (unless otherwise noted)

PARAMETER		TEST CONDITIONS	MIN	TYP	MAX	UNIT
SYNCHRONOUS RECTIFIER						
I _{OUT}	I _{OUT} at which the synchronous rectifier enters half synchronous mode, SYNC_EN	I _{LOAD} 200 → 0 mA	80	100	130	mA
	Hysteresis for I _{OUT,RECT-EN} (full-synchronous mode enabled)	I _{LOAD} 0 → 200 mA		25		mA
V _{HS-DIODE}	High-side diode drop when the rectifier is in half synchronous mode	I _{AC-VRECT} = 250 mA and T _J = 25°C		0.7		V
EN1 AND EN2						
V _{IL}	Input low threshold for EN1 and EN2				0.4	V
V _{IH}	Input high threshold for EN1 and EN2		1.3			V
R _{PD}	EN1 and EN2 pull down resistance			200		kΩ
ADC (WPC Related Measurements and Coefficients)						
I _{OUT} SENSE	Accuracy of the current sense over the load range	I _{OUT} = 750 - 1000 mA	-1.5	0	0.9	%

DEVICE INFORMATION

SIMPLIFIED BLOCK DIAGRAM

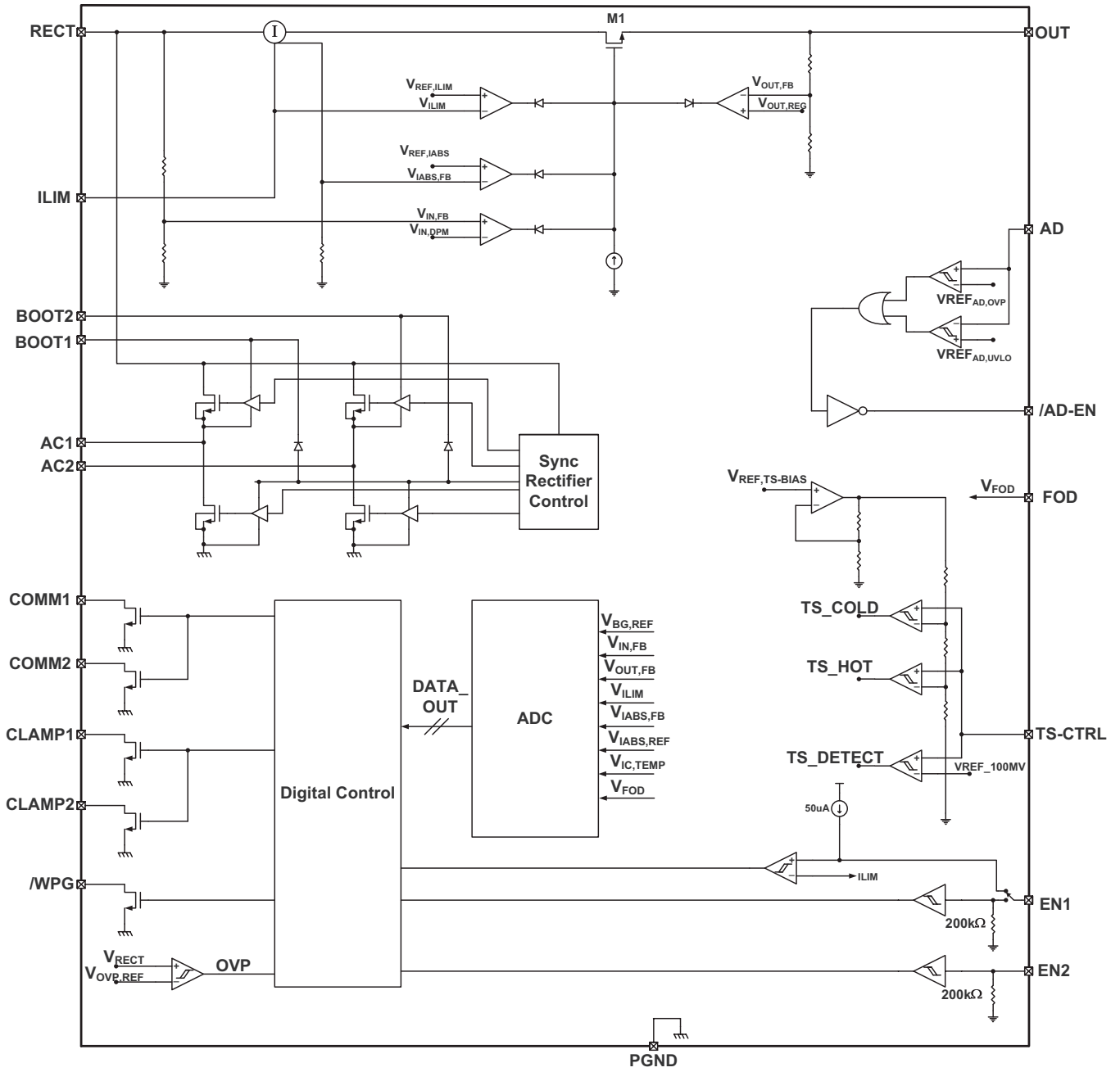

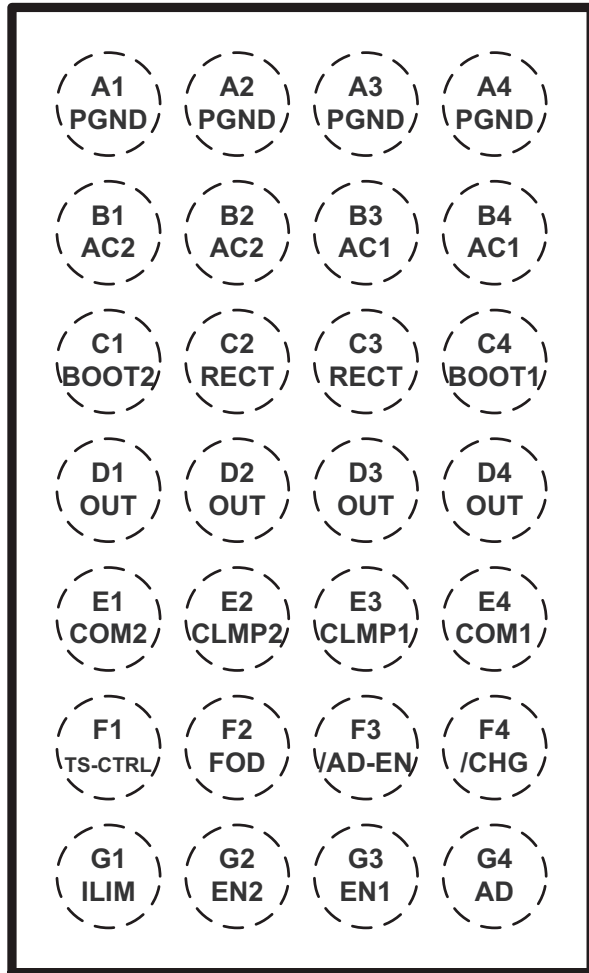
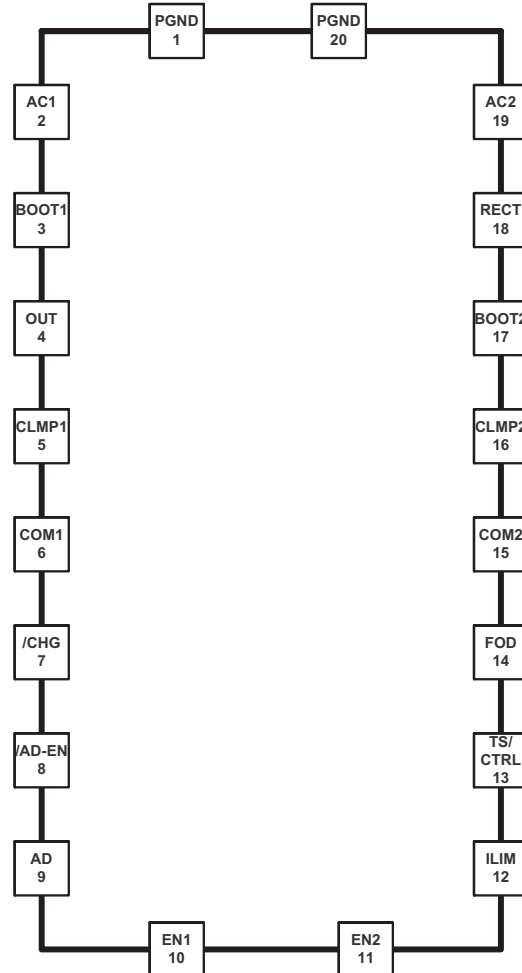
**YFP Package
(TOP VIEW)**

**RHL Package
(TOP VIEW)**

PIN FUNCTIONS

NAME	YFP	RHL	I/O	DESCRIPTION
AC1	B3, B4	2	I	AC input from receiver coil antenna.
AC2	B1, B2	19	I	
BOOT1	C4	3	O	Bootstrap capacitors for driving the high-side FETs of the synchronous rectifier. Connect a 10 nF ceramic capacitor from BOOT1 to AC1 and from BOOT2 to AC2.
BOOT2	C1	17	O	
RECT	C2, C3	18	O	Filter capacitor for the internal synchronous rectifier. Connect a ceramic capacitor to PGND. Depending on the power levels, the value may be 4.7 μ F to 22 μ F.
OUT	D1, D2, D3, D4	4	O	Output pin, delivers power to the load.
COM1	E4	6	O	Open-drain output used to communicate with primary by varying reflected impedance. Connect through a capacitor to either AC1 or AC2 for capacitive load modulation (COM2 must be connected to the alternate AC1 or AC2 pin). For resistive modulation connect COM1 and COM2 to RECT via a single resistor; connect through separate capacitors for capacitive load modulation.
COM2	E1	15	O	
CLMP2	E2	16	O	Open drain FETs which are utilized for a non-power dissipative over-voltage AC clamp protection. When the RECT voltage goes above 15 V, both switches will be turned on and the capacitors will act as a low impedance to protect the IC from damage. If used, Clamp1 is required to be connected to AC1, and Clamp2 is required to be connected to AC2 via 0.47 μ F capacitors.
CLMP1	E3	5	O	
PGND	A1, A2, A3, A4	1, 20		Power ground

PIN FUNCTIONS (continued)

NAME	YFP	RHL	I/O	DESCRIPTION
ILIM	G1	12	I/O	Programming pin for the over current limit. Connect external resistor to VSS. Size R _{ILIM} with the following equation: $R_{ILIM} = 250 / I_{MAX}$ where I _{MAX} is the expected maximum output current of the wireless power supply. The hardware current limit (I _{ILIM}) will be 20% greater than I _{MAX} or $1.2 \times I_{MAX}$. If the supply is meant to operate in current limit use $R_{ILIM} = 300 / I_{ILIM}$ $R_{ILIM} = R1 + 188$
AD	G4	9	I	Connect this pin to the wired adapter input. When a voltage is applied to this pin wireless charging is disabled and AD_EN is driven low. Connect to GND through a 1 μF capacitor. If unused, capacitor is not required and should be grounded directly.
$\overline{AD-EN}$	F3	8	O	Push-pull driver for external PFET connecting AD and OUT. This node is pulled to the higher of OUT and AD when turning off the external FET. This voltage tracks approximately 4 V below AD when voltage is present at AD and provides a regulated VSG bias for the external FET. Float this pin if unused.
TS-CTRL	F1	13	I	Must be connected to ground via a resistor. If an NTC function is not desired connect to GND with a 10 kΩ resistor. As a CTRL pin pull to ground to send end power transfer (EPT) fault to the transmitter or pull-up to an internal rail (i.e. 1.8 V) to send EPT termination to the transmitter. Note that a 3-state driver should be used to interface this pin (see the 3-state Driver section for further description)
EN1	G3	10	I	Inputs that allow user to enable/disable wireless and wired charging <EN1 EN2>: <00> wireless charging is enabled unless AD voltage > 3.6 V <01> Dynamic communication current limit disabled <10> AD-EN pulled low, wireless charging disabled <11> wired and wireless charging disabled.
EN2	G2	11	I	
FOD	F2	14	I	Input for the received power measurement. Connect to GND with a 188 Ω resistor. Please refer FOD section for more detail.
\overline{CHG}	F4	7	O	Open-drain output – active when output current is being delivered to the load (i.e. when the output of the supply is enabled).

TYPICAL CHARACTERISTICS

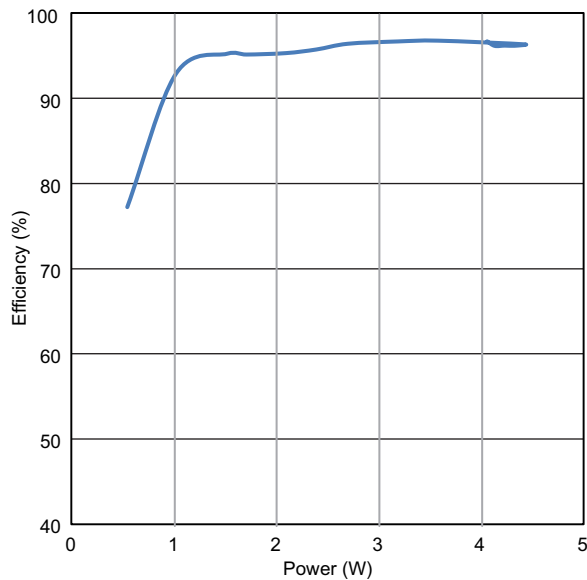

Figure 5. Rectifier Efficiency

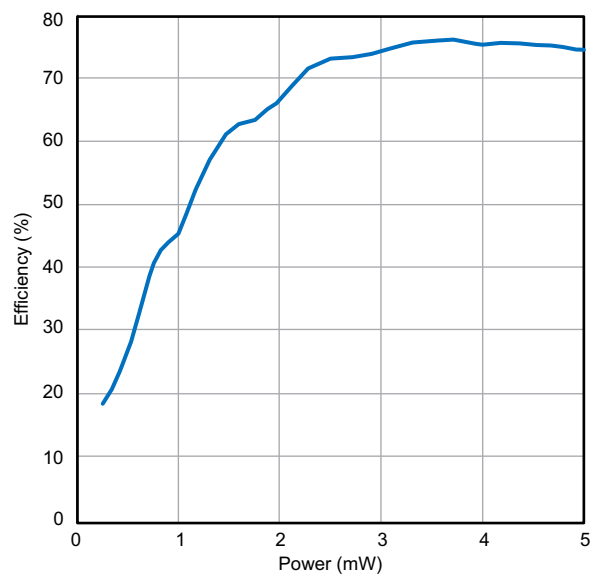

Figure 6. System Efficiency from DC Input to DC Output

TYPICAL CHARACTERISTICS (continued)

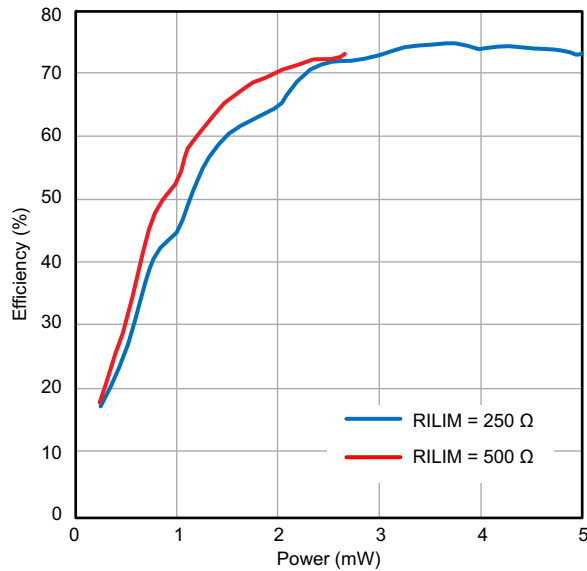

Figure 7. Light Load System Efficiency Improvement due to Dynamic Efficiency Scaling Feature(1)

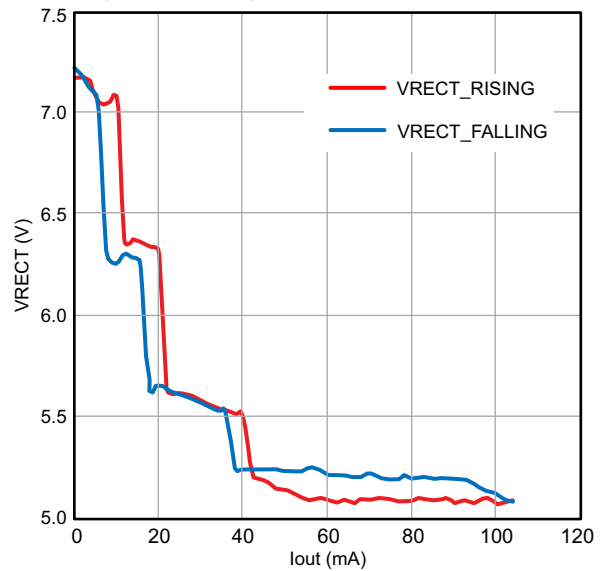

Figure 8. V_{RECT} vs. I_{LOAD} at $R_{ILIM} = 220\Omega$

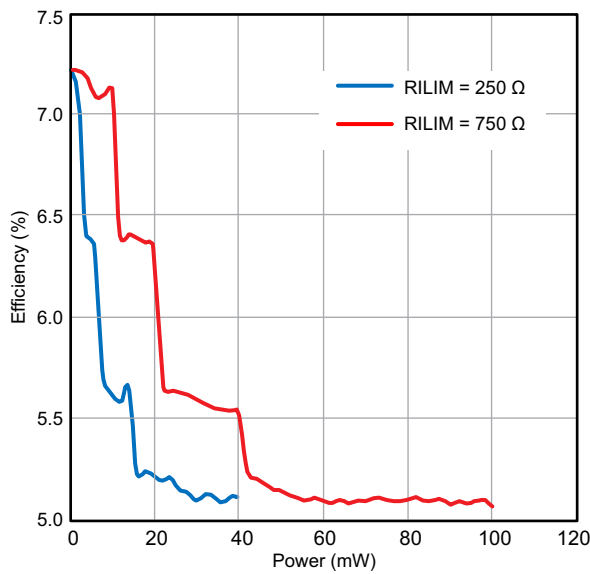

Figure 9. V_{RECT} vs. I_{LOAD} at $R_{ILIM} = 220\Omega$ and 500Ω

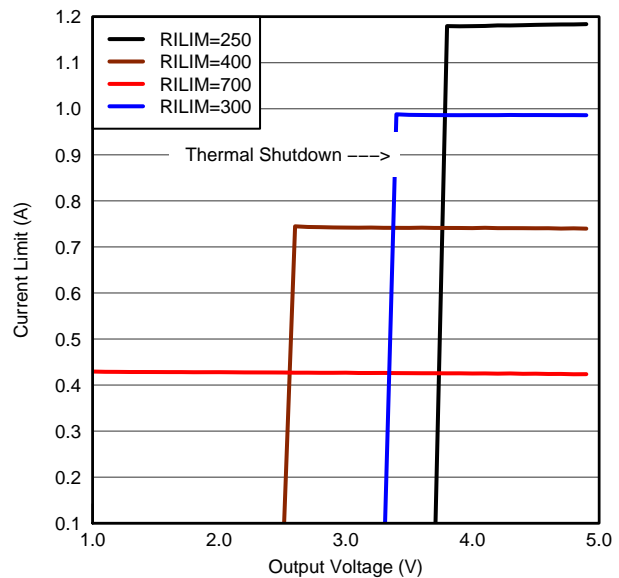

Figure 10. V_{OUT} Sweep (I-V Curve)(2)

G001

TYPICAL CHARACTERISTICS (continued)

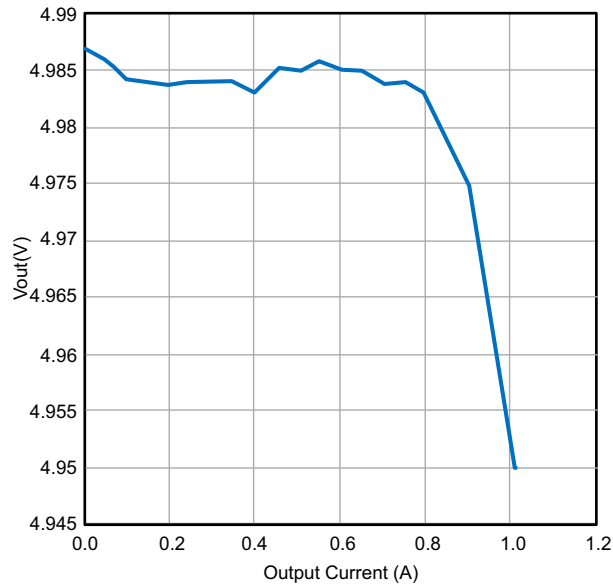

Figure 11. I_{LOAD} Sweep (I-V Curve)

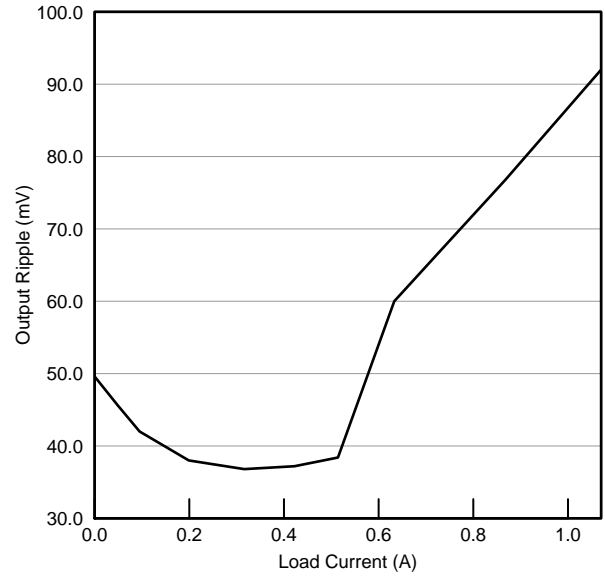

Figure 12. Output Ripple vs. I_{LOAD} (C_{OUT} = 1µF) without communication

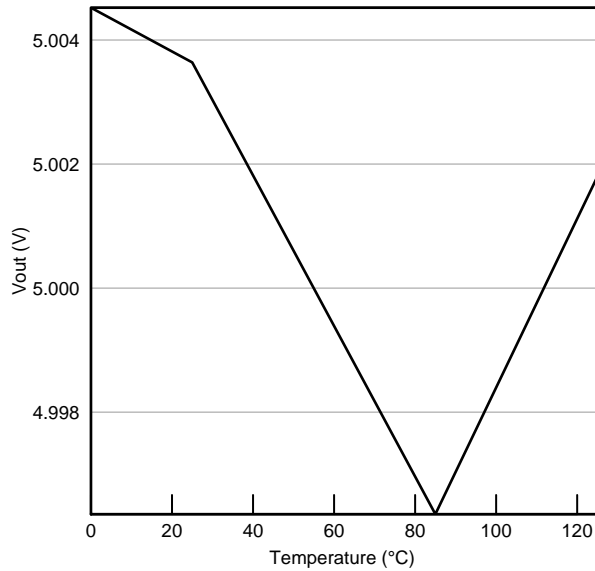

Figure 13. V_{OUT} vs Temperature

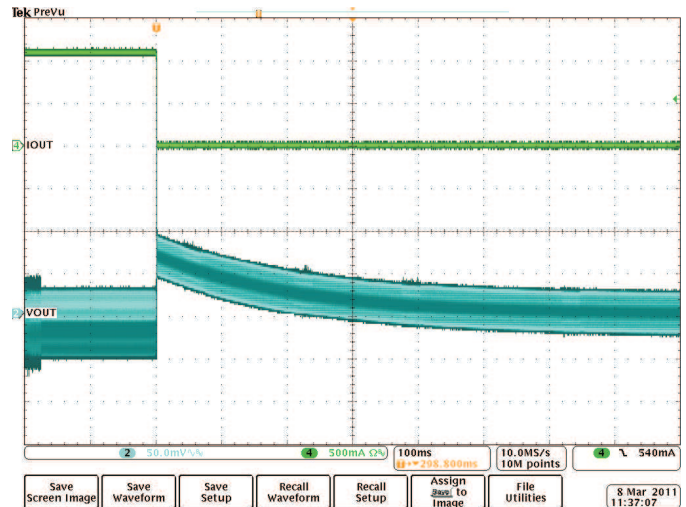

Figure 14. 1A Instantaneous Load Dump(3)

TYPICAL CHARACTERISTICS (continued)

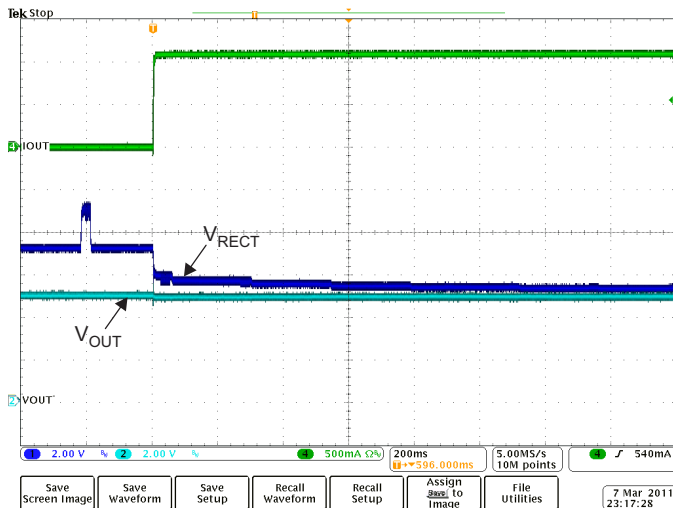

Figure 15. 1A Load Step Full System Response

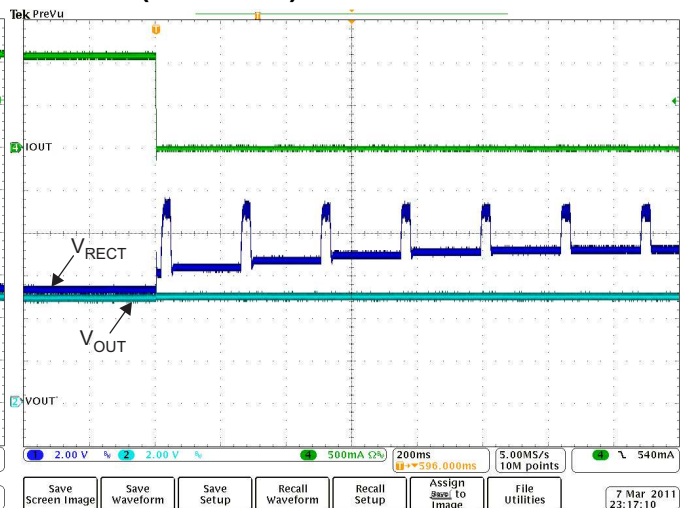

Figure 16. 1A Load Dump Full System Response

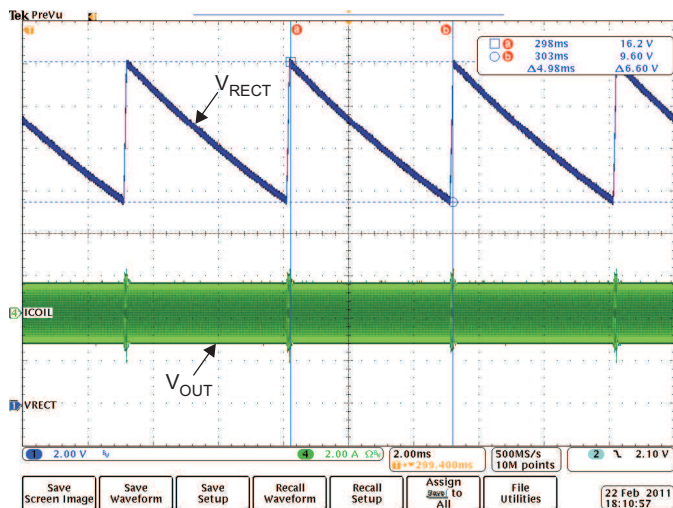

Figure 17. Rectifier Overvoltage Clamp ($f_{op} = 110\text{kHz}$)

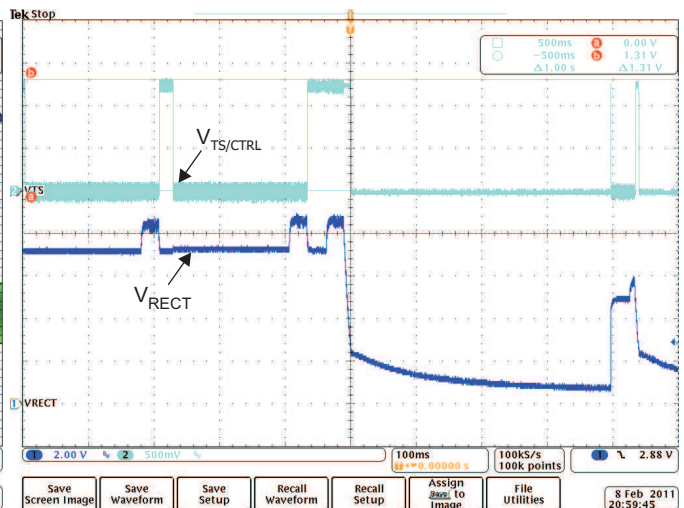

Figure 18. TS Fault

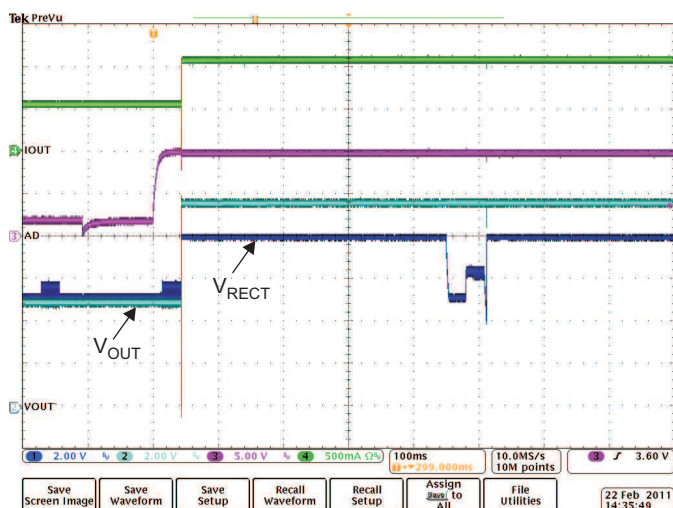

Figure 19. Adapter Insertion ($V_{AD} = 10\text{V}$)

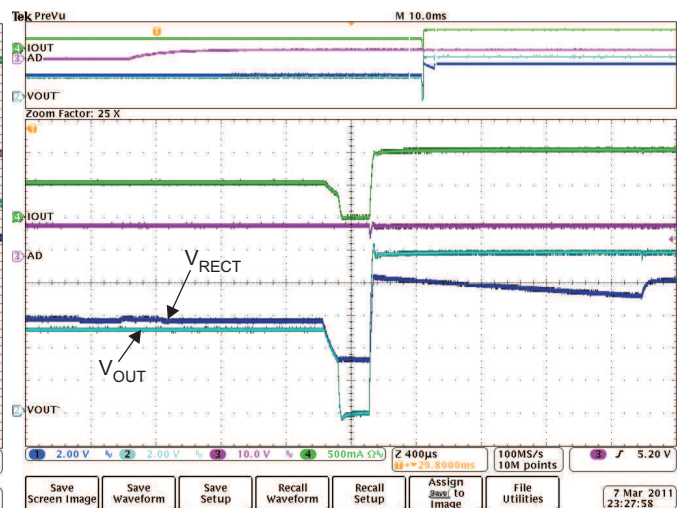

Figure 20. Adapter Insertion ($V_{AD} = 10\text{V}$) Illustrating Break-Before-Make Operation

TYPICAL CHARACTERISTICS (continued)

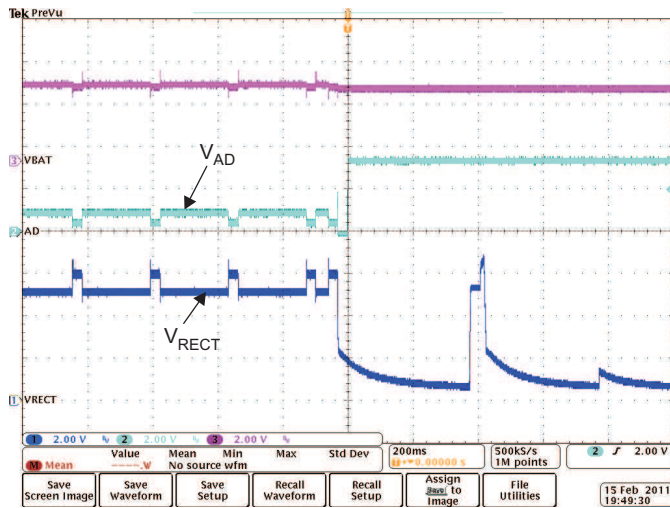

Figure 21. On the Go Enabled ($V_{OTG} = 3.5V$) (4)

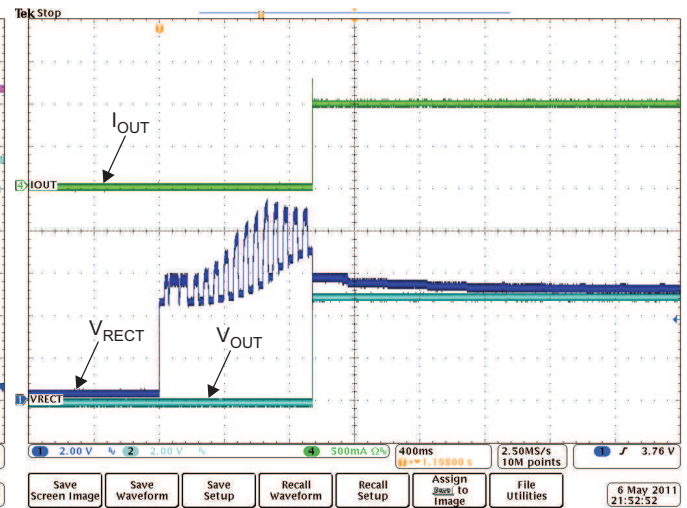

Figure 22. bq51013B Typical Startup with a 1A System Load

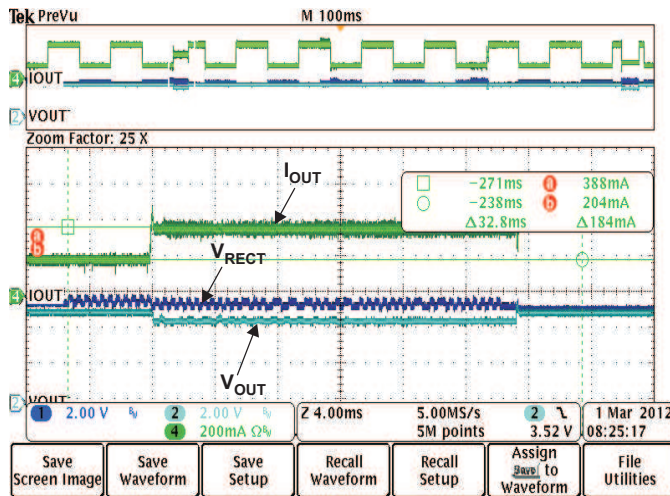

Figure 23. Adaptive Communication Limit Event Where the 400 mA Current Limit is Enabled ($I_{OUT-DC} < 300\text{ mA}$)

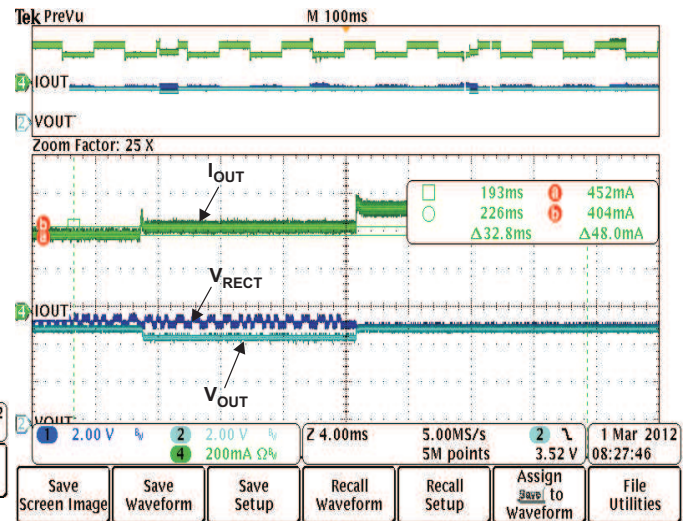

Figure 24. Adaptive Communication Limit Event Where the Current Limit is $I_{OUT} + 50\text{ mA}$ ($I_{OUT-DC} > 300\text{ mA}$)

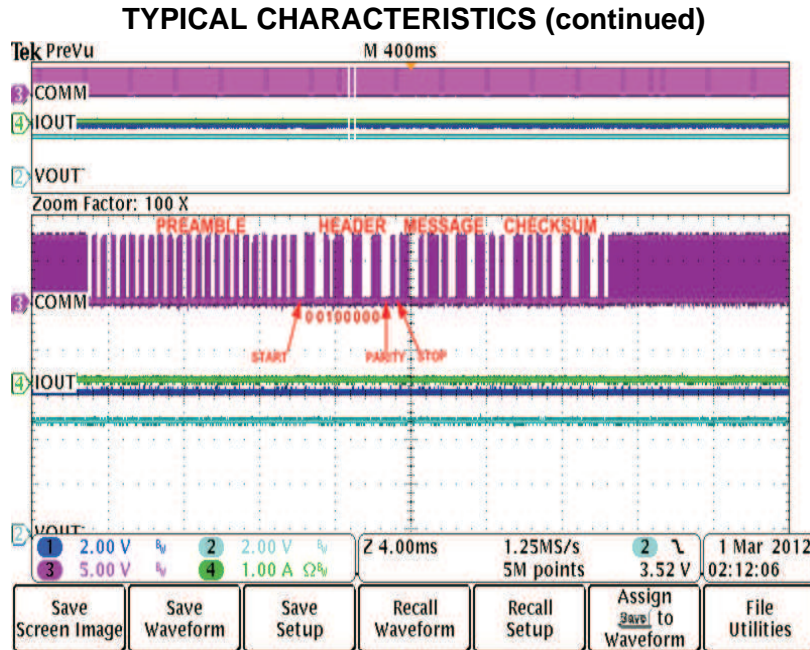

Figure 25. Rx Communication Packet Structure

- (1) Efficiency measured from DC input to the transmitter to DC output of the receiver. Transmitter was the bq500210 EVM. Measurement subject to change if an alternate transmitter is used.
- (2) Curves illustrates the resulting I_{LIM} current by sweeping the output voltage at different R_{LIM} settings. I_{LIM} current collapses due to the increasing power dissipation as the voltage at the output is decreased—thermal shutdown is occurring.
- (3) Total droop experienced at the output is dependent on receiver coil design. The output impedance must be low enough at that particular operating frequency in order to not collapse the rectifier below 5V.
- (4) On the go mode is enabled by driving EN1 high. In this test the external PMOS is connected between the output of the bq51013B IC and the AD pin; therefore, any voltage source on the output is supplied to the AD pin.

PRINCIPLE OF OPERATION

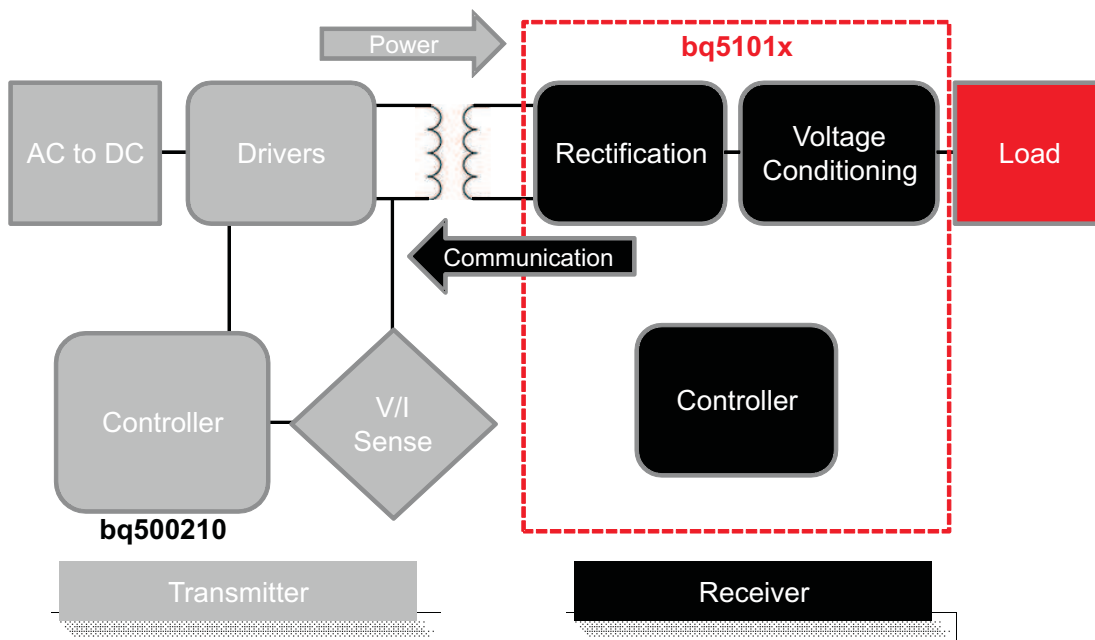

Figure 26. WPC Wireless Power System Indicating the Functional Integration of the bq5101xB

A Brief Description of the Wireless System:

A wireless system consists of a charging pad (transmitter or primary) and the secondary-side equipment (receiver or secondary). There is a coil in the charging pad and in the secondary equipment which are magnetically coupled to each other when the secondary is placed on the primary. Power is then transferred from the transmitter to the receiver via coupled inductors (e.g. an air-core transformer). Controlling the amount of power transferred is achieved by sending feedback (error signal) communication to the primary (e.g. to increase or decrease power).

The receiver communicates with the transmitter by changing the load seen by the transmitter. This load variation results in a change in the transmitter coil current, which is measured and interpreted by a processor in the charging pad. The communication is digital - packets are transferred from the receiver to the transmitter. Differential Bi-phase encoding is used for the packets. The bit rate is 2-kbps.

Various types of communication packets have been defined. These include identification and authentication packets, error packets, control packets, end power packets, and power usage packets.

The transmitter coil stays powered off most of the time. It occasionally wakes up to see if a receiver is present. When a receiver authenticates itself to the transmitter, the transmitter will remain powered on. The receiver maintains full control over the power transfer using communication packets.

Using the bq5101xB as a Wireless Power Supply: (See [Figure 3](#))

[Figure 3](#) is the schematic of a system which uses the bq51013B as power supply while power multiplexing the wired (adapter) port.

When the system shown in [Figure 3](#) is placed on the charging pad, the receiver coil is inductively coupled to the magnetic flux generated by the coil in the charging pad which consequently induces a voltage in the receiver coil. The internal synchronous rectifier feeds this voltage to the RECT pin which has the filter capacitor C3.

The bq5101xB identifies and authenticates itself to the primary using the COM pins by switching on and off the COM FETs and hence switching in and out C_{COMM} . If the authentication is successful, the transmitter will remain powered on. The bq5101xB measures the voltage at the RECT pin, calculates the difference between the actual voltage and the desired voltage $V_{RECT-REG}$, (threshold 1 at no load) and sends back error packets to the primary. This process goes on until the input voltage settles at $V_{RECT-REG}$. During a load transient, the dynamic rectifier algorithm will set the targets specified by $V_{RECT-REG}$ thresholds 1, 2, 3, and 4. This algorithm is termed Dynamic Rectifier Control and is used to enhance the transient response of the power supply.

During power-up, the LDO is held off until the $V_{RECT-REG}$ threshold 1 converges. The voltage control loop ensures that the output voltage is maintained at $V_{OUT-REG}$ to power the system. The bq5101xB meanwhile continues to monitor the input voltage, and maintains sending error packets to the primary every 250ms. If a large overshoot occurs, the feedback to the primary speeds up to every 32ms in order to converge on an operating point in less time.

Details of a Qi Wireless Power System and bq5101xB Power Transfer Flow Diagrams

The bq5101xB family integrates a fully compliant WPC v1.1 communication algorithm in order to streamline receiver designs (no extra software development required). Other unique algorithms such as Dynamic Rectifier Control are also integrated to provide best-in-class system performance. This section provides a high level overview of these features by illustrating the wireless power transfer flow diagram from startup to active operation.

During startup operation, the wireless power receiver must comply with proper handshaking to be granted a power contract from the Tx. The Tx will initiate the hand shake by providing an extended digital ping. If an Rx is present on the Tx surface, the Rx will then provide the signal strength, configuration and identification packets to the Tx (see volume 1 of the WPC specification for details on each packet). These are the first three packets sent to the Tx. The only exception is if there is a true shutdown condition on the EN1/EN2, AD, or TS-CTRL pins where the Rx will shut down the Tx immediately. See [Table 4](#) for details. Once the Tx has successfully received the signal strength, configuration and identification packets, the Rx will be granted a power contract and is then allowed to control the operating point of the power transfer. With the use of the bq5101xB Dynamic Rectifier Control algorithm, the Rx will inform the Tx to adjust the rectifier voltage above 7 V prior to enabling the output supply. This method enhances the transient performance during system startup. See [Figure 27](#) for the startup flow diagram details.

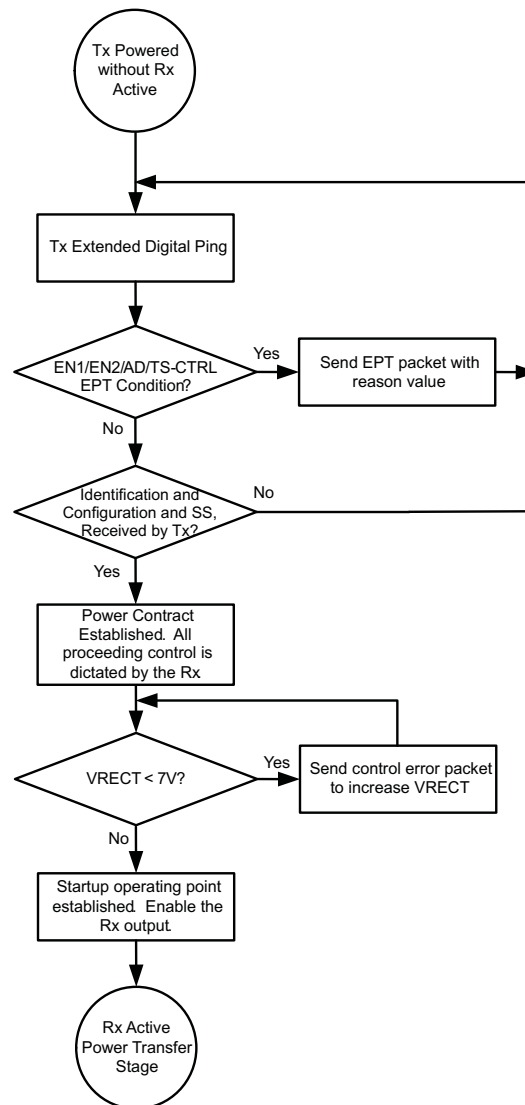

Figure 27. Wireless Power Startup Flow Diagram

Once the startup procedure has been established, the Rx will enter the active power transfer stage. This is considered the “main loop” of operation. The Dynamic Rectifier Control algorithm will determine the rectifier voltage target based on a percentage of the maximum output current level setting (set by K_{IMAX} and the $ILIM$ resistance to GND). The Rx will send control error packets in order to converge on these targets. As the output current changes, the rectifier voltage target will dynamically change. As a note, the feedback loop of the WPC system is relatively slow where it can take up to 90 ms to converge on a new rectifier voltage target. It should be understood that the instantaneous transient response of the system is open loop and dependent on the Rx coil output impedance at that operating point. More details on this will be covered in the section Receiver Coil Load-Line Analysis. The “main loop” will also determine if any conditions in [Table 4](#) are true in order to discontinue power transfer. See [Figure 28](#) which illustrates the active power transfer loop.

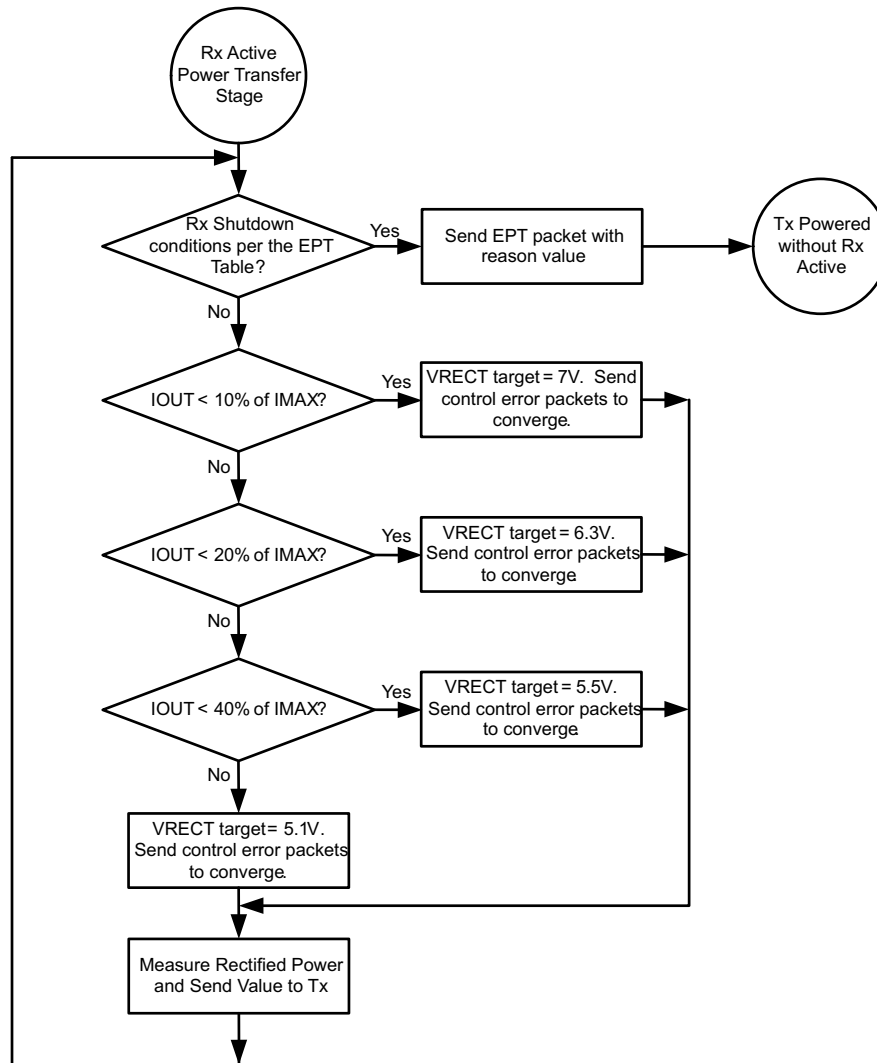

Figure 28. Active Power Transfer Flow Diagram

Another requirement of the WPC v1.1 specification is to send the measured received power. This task is enabled on the IC by measuring the voltage on the FOD pin which is proportional to the output current and can be scaled based on the choice of the resistor to ground on the FOD pin.

Dynamic Rectifier Control

The Dynamic Rectifier Control algorithm offers the end system designer optimal transient response for a given max output current setting. This is achieved by providing enough voltage headroom across the internal regulator at light loads in order to maintain regulation during a load transient. The WPC system has a relatively slow global feedback loop where it can take more than 90 ms to converge on a new rectifier voltage target. Therefore, the transient response is dependent on the loosely coupled transformers output impedance profile. The Dynamic Rectifier Control allows for a 2 V change in rectified voltage before the transient response will be observed at the output of the internal regulator (output of the bq5101xB). A 1-A application allows up to a 1.5 Ω output impedance. The Dynamic Rectifier Control behavior is illustrated in Figure 8 where R_{LIM} is set to 250 Ω.

Dynamic Efficiency Scaling

The Dynamic Efficiency Scaling feature allows for the loss characteristics of the bq5101xB to be scaled based on the maximum expected output power in the end application. This effectively optimizes the efficiency for each application. This feature is achieved by scaling the loss of the internal LDO based on a percentage of the maximum output current. Note that the maximum output current is set by the $K_{I_{MAX}}$ term and the R_{ILIM} resistance (where $R_{ILIM} = K_{I_{MAX}} / I_{MAX}$). The flow diagram show in [Figure 28](#) illustrates how the rectifier is dynamically controlled (*Dynamic Rectifier Control*) based on a fixed percentage of the I_{MAX} setting. The below table summarizes how the rectifier behavior is dynamically adjusted based on two different R_{ILIM} settings.

Table 1.

Output Current Percentage	$R_{ILIM} = 500\Omega$ $I_{MAX} = 0.5A$	$R_{ILIM} = 220\Omega$ $I_{MAX} = 1.14A$	V_{RECT}
0 to 10%	0 A to 0.05 A	0 A to 0.114 A	7.08 V
10 to 20%	0.05 A to 0.1A	0.114 A to 0.227 A	6.28 V
20 to 40%	0.1 A to 0.2 A	0.227 A to 0.454 A	5.53 V
>40%	> 0.2 A	> 0.454 A	5.11 V

[Figure 9](#) illustrates the shift in the *Dynamic Rectifier Control* behavior based on the two different R_{ILIM} settings. With the rectifier voltage (V_{RECT}) being the input to the internal LDO, this adjustment in the *Dynamic Rectifier Control* thresholds will dynamically adjust the power dissipation across the LDO where:

$$P_{DIS} = (V_{RECT} - V_{OUT}) \times I_{OUT} \quad (1)$$

[Figure 7](#) illustrates how the system efficiency is improved due to the *Dynamic Efficiency Scaling* feature. Note that this feature balances efficiency with optimal system transient response.

R_{ILIM} Calculations

The bq5101xB includes a means of providing hardware overcurrent protection by means of an analog current regulation loop. The hardware current limit provides an extra level of safety by clamping the maximum allowable output current (e.g. a current compliance). The R_{ILIM} resistor size also sets the thresholds for the dynamic rectifier levels and thus providing efficiency tuning per each application's maximum system current. The calculation for the total R_{ILIM} resistance is as follows:

$$R_{ILIM} = \frac{262}{I_{MAX}}$$

$$I_{ILIM} = 1.2 \times I_{MAX} = \frac{314}{R_{ILIM}}$$

$$R_{ILIM} = R_1 + 188 \quad (2)$$

Where I_{MAX} is the expected maximum output current during normal operation and I_{ILIM} is the hardware over current limit. When referring to the application diagram shown in [Figure 2](#), R_{ILIM} is the sum of 188 and the R_1 resistance (e.g. the total resistance from the ILIM pin to GND).

Input Overvoltage

If the input voltage suddenly increases in potential (e.g. due to a change in position of the equipment on the charging pad), the voltage-control loop inside the bq5101xB becomes active, and prevents the output from going beyond $V_{OUT-REG}$. The receiver then starts sending back error packets to the transmitter every 30ms until the input voltage comes back to the $V_{RECT-REG}$ target, and then maintains the error communication every 250ms.

If the input voltage increases in potential beyond V_{OVP} , the IC switches off the LDO and communicates to the primary to bring the voltage back to $V_{RECT-REG}$. In addition, a proprietary voltage protection circuit is activated by means of C_{CLAMP1} and C_{CLAMP2} that protects the IC from voltages beyond the maximum rating of the IC (e.g. 20V).

Adapter Enable Functionality and EN1/EN2 Control

Figure 3 is an example application that shows the bq5101xB used as a wireless power receiver that can power multiplex between wired or wireless power for the down-system electronics. In the default operating mode pins EN1 and EN2 are low, which activates the adapter enable functionality. In this mode, if an adapter is not present the AD pin will be low, and AD-EN pin will be pulled to the higher of the OUT and AD pins so that the PMOS between OUT and AD will be turned off. If an adapter is plugged in and the voltage at the AD pin goes above 3.6V then wireless charging is disabled and the AD-EN pin will be pulled approximately 4V below the AD pin to connect AD to the secondary charger. The difference between AD and AD-EN is regulated to a maximum of 7V to ensure the V_{GS} of the external PMOS is protected.

The EN1 and EN2 pins include internal 200k Ω pull-down resistors, so that if these pins are not connected bq5101xB defaults to AD-EN control mode. However, these pins can be pulled high to enable other operating modes as described in Table 2:

Table 2.

EN1	EN2	Result
0	0	Adapter control enabled. If adapter is present then secondary charger is powered by adapter, otherwise wireless charging is enabled when wireless power is available. Communication current limit is enabled.
0	1	Disables communication current limit.
1	0	AD-EN is pulled low, whether or not adapter voltage is present. This feature can be used, e.g., for USB OTG applications.
1	1	Adapter and wireless charging are disabled, i.e., power will never be delivered by the OUT pin in this mode.

Table 3.

EN1	EN2	Wireless Power	Wired Power	OTG Mode	Adaptive Communication Limit	EPT
0	0	Enabled	Priority ⁽¹⁾	Disabled	Enabled	Not Sent to Tx
0	1	Priority ⁽¹⁾	Enabled	Disabled	Disabled	Not Sent to Tx
1	0	Disabled	Enabled	Enabled ⁽²⁾	N/A	No Response
1	1	Disabled	Disabled	Disabled	N/A	Termination

(1) If both wired and wireless power are present, wired power is given priority.

(2) Allows for a boost-back supply to be driven from the output terminal of the Rx to the adapter port via the external back-to-back PMOS FET.

As described in Table 3, pulling EN2 high disables the adapter mode and only allows wireless charging. In this mode the adapter voltage will always be blocked from the OUT pin. An application example where this mode is useful is when USB power is present at AD, but the USB is in suspend mode so that no power can be taken from the USB supply. Pulling EN1 high enables the off-chip PMOS regardless of the presence of a voltage. This function can be used in USB OTG mode to allow a charger connected to the OUT pin to power the AD pin. Finally, pulling both EN1 and EN2 high disables both wired and wireless charging.

NOTE

It is required to connect a back-to-back PMOS between AD and OUT so that voltage is blocked in both directions. Also, when AD mode is enabled no load can be pulled from the RECT pin as this could cause an internal device overvoltage in bq5101xB.

End Power Transfer Packet (WPC Header 0x02)

The WPC allows for a special command for the receiver to terminate power transfer from the transmitter termed End Power Transfer (EPT) packet. Table 4 specifies the v1.1 reasons column and their corresponding data field value. The condition column corresponds to the methodology used by bq5101xB to send equivalent message.

Table 4.

Message	Value	Condition
Unknown	0x00	AD > 3.6V
Charge Complete	0x01	TS/CTRL = 1, or EN1 = 1, or <EN1 EN2> = <11>
Internal Fault	0x02	$T_J > 150^{\circ}\text{C}$ or $R_{LIM} < 100\Omega$
Over Temperature	0x03	$TS < V_{HOT}$, $TS > V_{COLD}$, or $TS/CTRL < 100\text{mV}$
Over Voltage	0x04	Not Sent
Over Current	0x05	NOT USED
Battery Failure	0x06	Not Sent
Reconfigure	0x07	Not Sent
No Response	0x08	VRECT target doesn't converge

Status Outputs

The bq5101xB has one status output, $\overline{\text{CHG}}$. This output is an open-drain NMOS device that is rated to 20V. The open-drain FET connected to the CHG pin will be turned on whenever the output of the power supply is enabled. Please note, the output of the power supply will not be enabled if the $V_{RECT-REG}$ does not converge at the no-load target voltage.

WPC Communication Scheme

The WPC communication uses a modulation technique termed “back-scatter modulation” where the receiver coil is dynamically loaded in order to provide amplitude modulation of the transmitter's coil voltage and current. This scheme is possible due to the fundamental behavior between two loosely coupled inductors (e.g. between the Tx and Rx coil). This type of modulation can be accomplished by switching in and out a resistor at the output of the rectifier, or by switching in and out a capacitor across the AC1/AC2 net. Figure 29 shows how to implement resistive modulation.

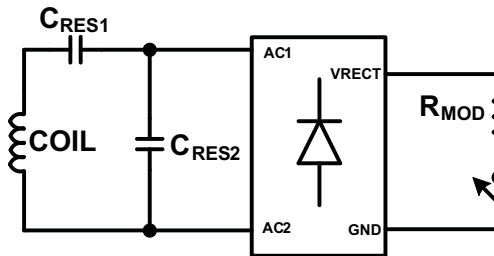

Figure 29. Resistive Modulation

Figure 30 Shows how to implement capacitive modulation.

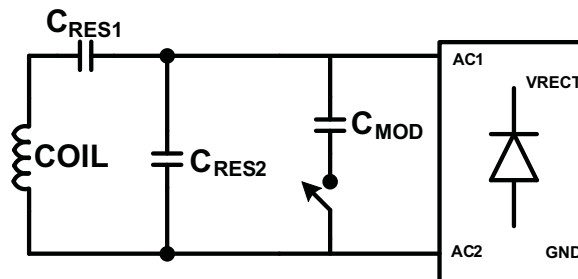

Figure 30. Capacitive Modulation

The amplitude change in Tx coil voltage or current can be detected by the transmitters decoder. The resulting signal observed by the Tx is shown in Figure 31.

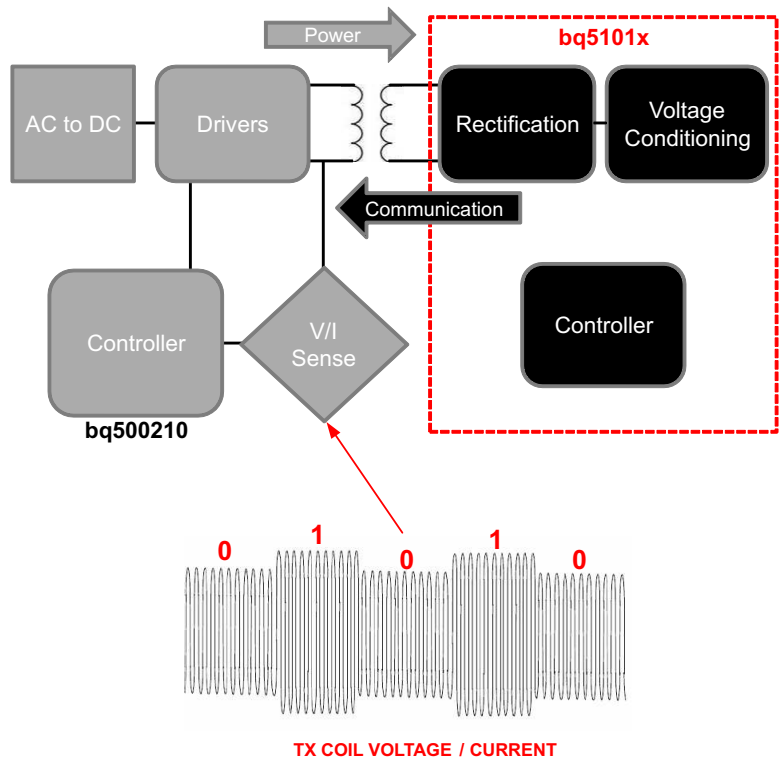

Figure 31.

The WPC protocol uses a differential bi-phase encoding scheme to modulate the data bits onto the Tx coil voltage/current. Each data bit is aligned at a full period of 0.5 ms (t_{CLK}) or 2 kHz. An encoded ONE results in two transitions during the bit period and an encoded ZERO results in a single transition. See Figure 32 for an example of the differential bi-phase encoding.

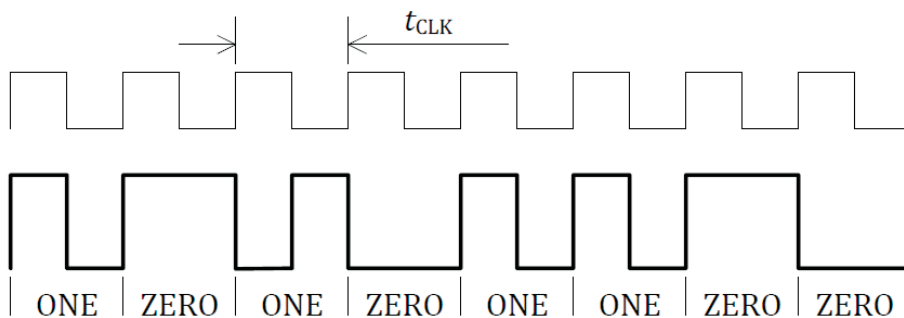

Figure 32. Differential Bi-phase Encoding Scheme (WPC volume 1: Low Power, Part 1 Interface Definition)

The bits are sent LSB first and use an 11-bit asynchronous serial format for each portion of the packet. This includes one start bit, n-data bytes, a parity bit, and a single stop bit. The start bit is always ZERO and the parity bit is odd. The stop bit is always ONE. Figure 33 shows the details of the asynchronous serial format.

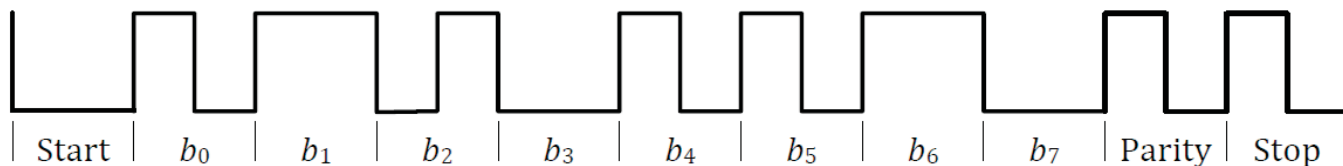

Figure 33. Asynchronous Serial Formatting (WPC volume 1: Low Power, Part 1 Interface Definition)

Each packet format is organized as shown in [Figure 34](#).



Figure 34. Packet Format (WPC volume 1: Low Power, Part 1 Interface Definition)

[Figure 25](#) above shows an example waveform of the receiver sending a rectified power packet (header 0x04).

Communication Modulator

The bq5101xB provides two identical, integrated communication FETs which are connected to the pins COM1 and COM2. These FETs are used for modulating the secondary load current which allows bq5101xB to communicate error control and configuration information to the transmitter. [Figure 35](#) below shows how the COMM pins can be used for resistive load modulation. Each COMM pin can handle at most a 24Ω communication resistor. Therefore, if a COMM resistor between 12Ω and 24Ω is required COM1 and COM2 pins must be connected in parallel. bq5101xB does not support a COMM resistor less than 12Ω.

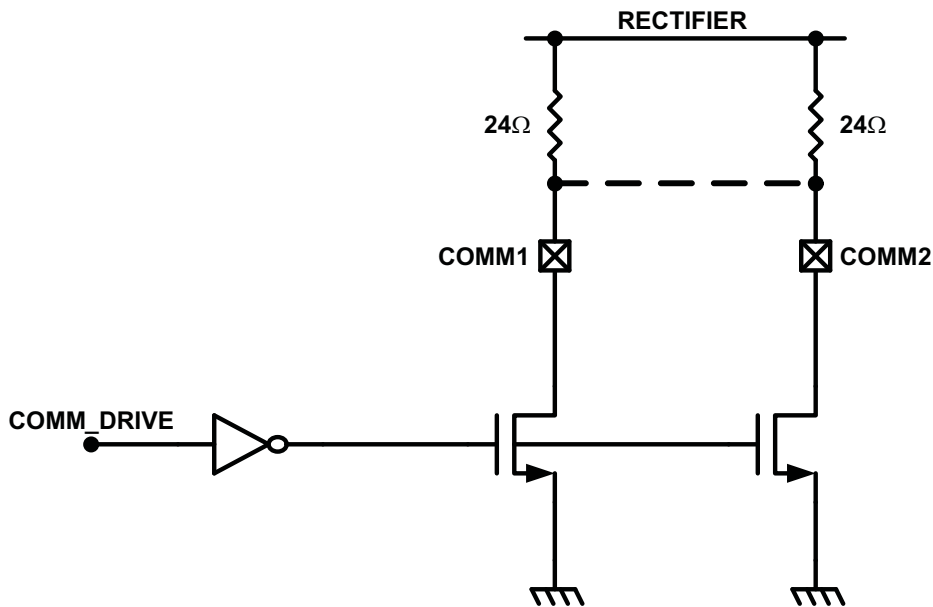

Figure 35. Resistive Load Modulation

In addition to resistive load modulation, the bq5101xB is also capable of capacitive load modulation as shown in [Figure 36](#) below. In this case, a capacitor is connected from COM1 to AC1 and from COM2 to AC2. When the COMM switches are closed there is effectively a 22 nF capacitor connected between AC1 and AC2. Connecting a capacitor in between AC1 and AC2 modulates the impedance seen by the coil, which will be reflected in the primary as a change in current.

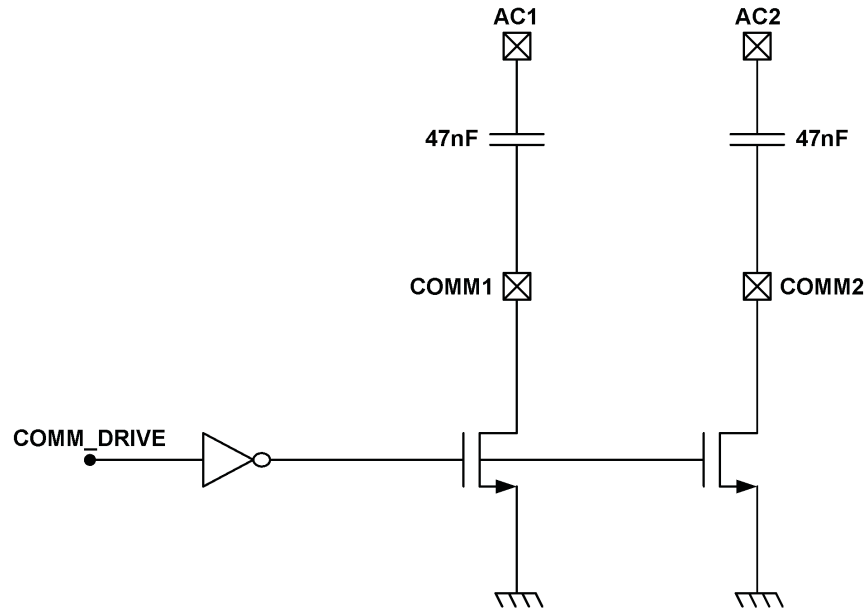

Figure 36. Capacitive Load Modulation

Adaptive Communication Limit

The Qi communication channel is established via backscatter modulation as described in the previous sections. This type of modulation takes advantage of the loosely coupled inductor relationship between the Rx and Tx coil. Essentially the switching in-and-out of the communication capacitor or resistor adds a transient load to the Rx coil in order to modulate the Tx coil voltage/current waveform (amplitude modulation). The consequence of this technique is that a load transient (load current noise) from the mobile device has the same signature. In order to provide noise immunity to the communication channel, the output load transients must be isolated from the Rx coil. The proprietary feature *Adaptive Communication Limit* achieves this by dynamically adjusting the current limit of the regulator. When the regulator is put in current limit, any load transients will be offloaded to the battery in the system.

Note that this requires the battery charger IC to have input voltage regulation (weak adapter mode). The output of the Rx appears as a weak supply if a transient occurs above the current limit of the regulator.

The Adaptive Communication Limit feature has two current limit modes and is detailed in the table below:

Table 5.

I_{OUT}	Communication Current Limit
< 300 mA	Fixed 400 mA
> 300 mA	$I_{OUT} + 50$ mA

The first mode is illustrated in Figure 23. In this plot, an output load pulse of 300 mA is periodically introduced on a DC current level of 200 mA. Therefore, the 400 mA current limit is enabled. The pulses on V_{RECT} indicate that a communication packet event is occurring. When the output load pulse occurs, the regulator limits the pulse to a constant 400 mA and; therefore, preserves communication. Note that V_{OUT} drops to 4.5 V instead of GND. A charger IC with an input voltage regulation set to 4.5 V allows this to occur by offloading the load transient support to the mobile device's battery

The second mode is illustrated in Figure 24. In this plot, an output pulse of 200 mA is periodically introduced on a DC current level of 400 mA. Therefore, the tracking current mode ($I_{OUT} + 50$ mA) is enabled. In this mode the bq5101xB measures the active output current and sets the regulators current limit 50 mA above this measurement. When the load pulse occurs during a communication packet event, the output current is regulated to 450 mA. As the communication packet event has finished the output load is allowed to increase. Note that during the time the regulator is in current limit V_{OUT} is reduced to 4.5 V and 5 V when not in current limit.

Synchronous Rectification

The bq5101xB provides an integrated, self-driven synchronous rectifier that enables high-efficiency AC to DC power conversion. The rectifier consists of an all NMOS H-Bridge driver where the backgates of the diodes are configured to be the rectifier when the synchronous rectifier is disabled. During the initial startup of the WPC system the synchronous rectifier is not enabled. At this operating point, the DC rectifier voltage is provided by the diode rectifier. Once V_{RECT} is greater than $UVLO$, half synchronous mode will be enabled until the load current surpasses 120 mA. Above 120 mA the full synchronous rectifier stays enabled until the load current drops back below 100 mA where half synchronous mode is enabled instead.

Temperature Sense Resistor Network (TS)

bq5101xB includes a ratiometric external temperature sense function. The temperature sense function has two ratiometric thresholds which represent a hot and cold condition. An external temperature sensor is recommended in order to provide safe operating conditions for the receiver product. This pin is best used for monitoring the surface that can be exposed to the end user (e.g. place the NTC resistor closest to the user).

Figure 37 allows for any NTC resistor to be used with the given V_{HOT} and V_{COLD} thresholds.

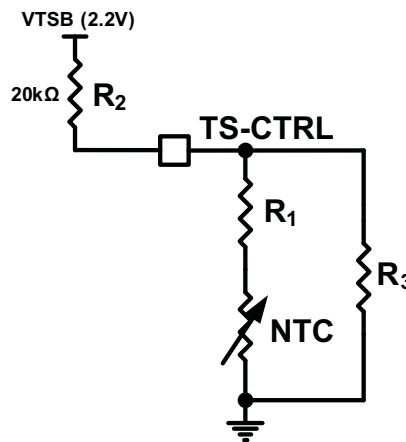

Figure 37. NTC Circuit Used for Safe Operation of the Wireless Receiver Power Supply

The resistors R_1 and R_3 can be solved by resolving the system of equations at the desired temperature thresholds. The two equations are:

$$\%V_{COLD} = \frac{\left(\frac{R_3 (R_{NTC|TCOLD} + R_1)}{R_3 + (R_{NTC|TCOLD} + R_1)} \right)}{\left(\frac{R_3 (R_{NTC|TCOLD} + R_1)}{R_3 + (R_{NTC|TCOLD} + R_1)} \right) + R_2} \times 100$$

$$\%V_{HOT} = \frac{\left(\frac{R_3 (R_{NTC|THOT} + R_1)}{R_3 + (R_{NTC|THOT} + R_1)} \right)}{\left(\frac{R_3 (R_{NTC|THOT} + R_1)}{R_3 + (R_{NTC|THOT} + R_1)} \right) + R_2} \times 100 \quad (3)$$

Where:

$$R_{NTC}|_{TCOLD} = R_o e^{\beta \left(\frac{1}{TCOLD} - \frac{1}{T_o} \right)}$$

$$R_{NTC}|_{THOT} = R_o e^{\beta \left(\frac{1}{THOT} - \frac{1}{T_o} \right)}$$
(4)

where, T_{COLD} and T_{HOT} are the desired temperature thresholds in degrees Kelvin. R_o is the nominal resistance and β is the temperature coefficient of the NTC resistor. R_o is fixed at 20 k Ω . An example solution is provided:

- $R1 = 4.23k\Omega$
- $R3 = 66.8k\Omega$

where the chosen parameters are:

- $\%V_{HOT} = 19.6\%$
- $\%V_{COLD} = 58.7\%$
- $T_{COLD} = -10^{\circ}C$
- $T_{HOT} = 100^{\circ}C$
- $\beta = 3380$
- $R_o = 10k\Omega$

The plot of the percent V_{TSB} vs. temperature is shown in [Figure 38](#):

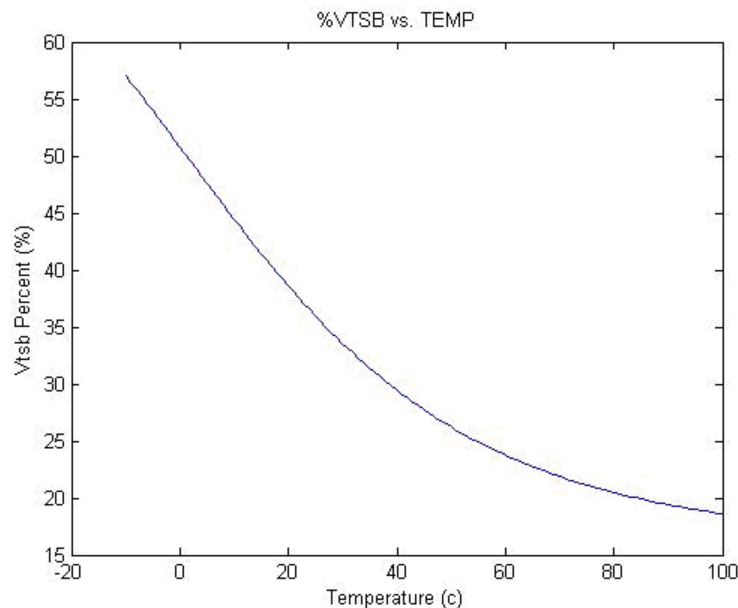

Figure 38. Example Solution for an NTC resistor with $R_o = 10k\Omega$ and $\beta = 4500$

[Figure 39](#) illustrates the periodic biasing scheme used for measuring the TS state. The TS_READ signal enables the TS bias voltage for 24ms. During this period the TS comparators are read (each comparator has a 10 ms deglitch) and appropriate action is taken based on the temperature measurement. After this 24ms period has elapsed, the TS_READ signal goes low, which causes the TS-Bias pin to become high impedance. During the next 35ms (priority packet period) or 235ms (standard packet period), the TS voltage is monitored and compared to 100mV. If the TS voltage is greater than 100mV then a secondary device is driving the $TS/CTRL$ pin and a $CTRL = '1'$ is detected.

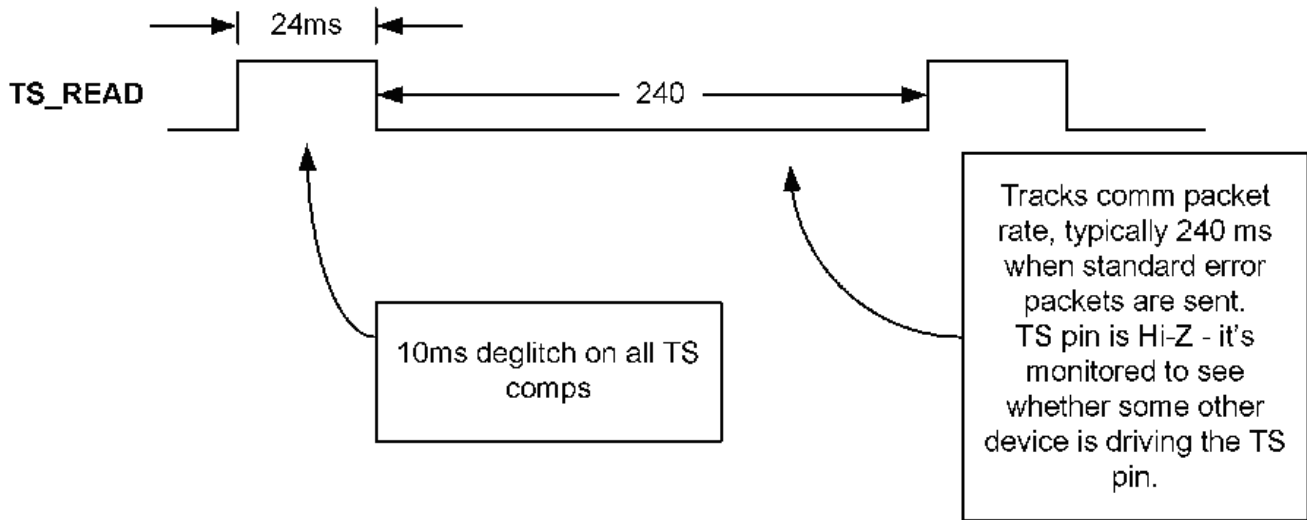

Figure 39. Timing Diagram for TS Detection Circuit

3-state Driver Recommendations for the TS-CTRL Pin

The TS-CTRL pin offers three functions with one 3-state driver interface

1. NTC temperature monitoring,
2. Fault indication,
3. Charge done indication

A 3-state driver can be implemented with the circuit in [Figure 40](#) and the use of two GPIO connections.

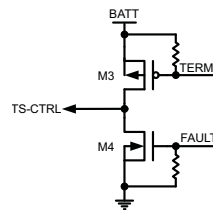

Figure 40. 3-state Driver for TS-CTRL

Note that the signals “TERM” and “FAULT” are given by two GPIOs. The truth table for this circuit is found in [Table 6](#):

Table 6.

TERM	FAULT	F (Result)
1	0	Z (Normal Mode)
0	0	Charge Complete
1	1	System Fault

The default setting is TERM = 1 and FAULT = 0. In this condition, the TS-CTRL net is high impedance (hi-z) and; therefore, the NTC is function is allowed to operate. When the TS-CTRL pin is pulled to GND by setting FAULT = 1, the Rx is shutdown with the indication of a fault. When the TS-CTRL pin is pulled to the battery by setting TERM = 1, the Rx is shutdown with the indication of a charge complete condition. Therefore, the host controller can indicate whether the Rx is system is turning off due to a fault or due to a charge complete condition.

Thermal Protection

The bq5101xB includes a thermal shutdown protection. If the die temperature reaches $T_J(\text{OFF})$, the LDO is shut off to prevent any further power dissipation. In this case bq51013B will send an EPT message of internal fault (0x02).

WPC 1.1 Compliance – Foreign Object Detection

The bq5101xB is a WPC 1.1 compatible device. In order to enable a Power Transmitter to monitor the power loss across the interface as one of the possible methods to limit the temperature rise of Foreign Objects, the bq5101xB reports its Received Power to the Power Transmitter. The Received Power equals the power that is available from the output of the Power Receiver plus any power that is lost in producing that output power (the power loss in the Secondary Coil and series resonant capacitor, the power loss in the Shielding of the Power Receiver, the power loss in the rectifier). In WPC1.1 specification, foreign object detection (FOD) is enforced. This means the bq5101xB will send received power information with known accuracy to the transmitter.

WPC 1.1 defines Received Power as “the average amount of power that the Power Receiver receives through its Interface Surface, in the time window indicated in the Configuration Packet”.

In order to receive certification as a WPC 1.1 receiver, the Device Under Test (DUT) is tested on a Reference Transmitter whose transmitted power is calibrated, the receiver must send a received power such that:

$$0 < (\text{TX PWR})_{\text{REF}} - (\text{RX PWR out})_{\text{DUT}} < -250\text{mW} \quad (5)$$

This 250mW bias ensures that system will remain interoperable.

WPC 1.1 Transmitter will be tested to see if they can detect reference Foreign Objects with a Reference receiver. WPC1.1 Specification will allow much more accurate sensing of Foreign Objects.

Series and Parallel Resonant Capacitor Selection

Shown in [Figure 2](#), the capacitors C1 (series) and C2 (parallel) make up the dual resonant circuit with the receiver coil. These two capacitors must be sized correctly per the WPC v1.1 specification. [Figure 41](#) illustrates the equivalent circuit of the dual resonant circuit:

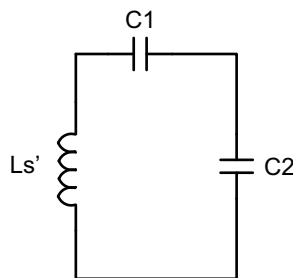

Figure 41. Dual Resonant Circuit with the Receiver Coil

Section 4.2 (Power Receiver Design Requirements) in Part 1 of the WPC v1.1 specification highlights in detail the sizing requirements. To summarize, the receiver designer will be required take inductance measurements with a fixed test fixture. The test fixture is shown in [Figure 42](#):

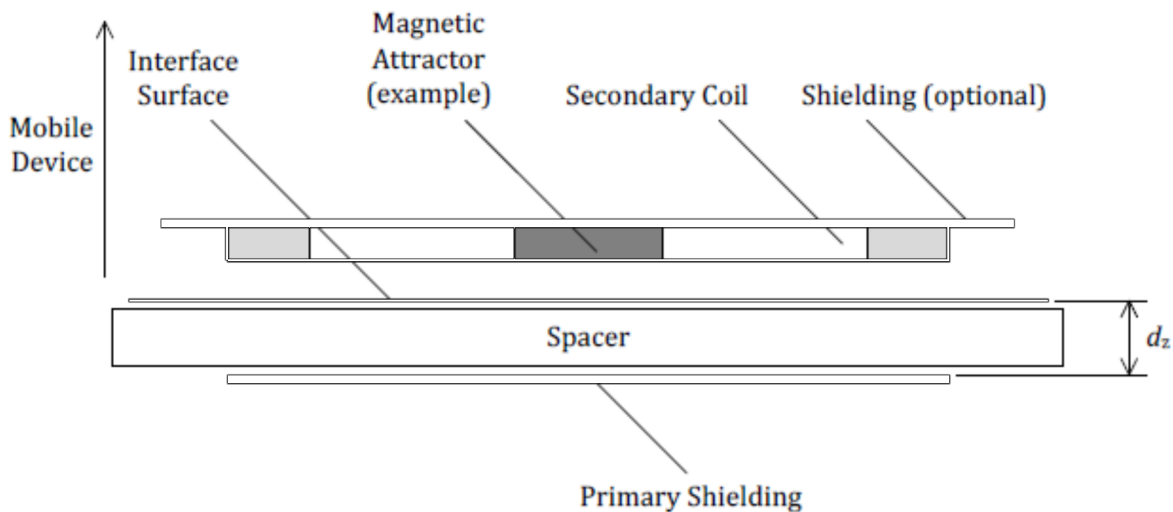

Figure 42. WPC v1.1 Receiver Coil Test Fixture for the Inductance Measurement L_s' (copied from System Description Wireless Power Transfer, volume 1: Low Power, Part 1 Interface Definition, Version 1.1)

The primary shield is to be 50 mm x 50 mm x 1 mm of Ferrite material PC44 from TDK Corp. The gap d_z is to be 3.4 mm. The receiver coil, as it will be placed in the final system (e.g. the back cover and battery must be included if the system calls for this), is to be placed on top of this surface and the inductance is to be measured at 1-V RMS and a frequency of 100 kHz. This measurement is termed L_s' . The same measurement is to be repeated without the test fixture shown in Figure 12. This measurement is termed L_s or the free-space inductance. Each capacitor can then be calculated using Equation 6:

$$C_1 = \left[(f_S \cdot 2\pi)^2 \cdot L_S' \right]^{-1}$$

$$C_2 = \left[(f_D \cdot 2\pi)^2 \cdot L_S - \frac{1}{C_1} \right]^{-1}$$
(6)

Where f_S is 100 kHz +5/-10% and f_D is 1 MHz \pm 10%. C_1 must be chosen first prior to calculating C_2 .

The quality factor must be greater than 77 and can be determined by Equation 7:

$$Q = \frac{2\pi \cdot f_D \cdot L_S}{R}$$
(7)

where R is the DC resistance of the receiver coil. All other constants are defined above.

Receiver Coil Load-Line Analysis

When choosing a receiver coil, it is recommend to analyze the transformer characteristics between the primary coil and receiver coil via load-line analysis. This will capture two important conditions in the WPC system:

1. Operating point characteristics in the closed loop of the WPC system.
2. Instantaneous transient response prior to the convergence of the new operating point.

An example test configuration for conducting this analysis is shown in Figure 43:

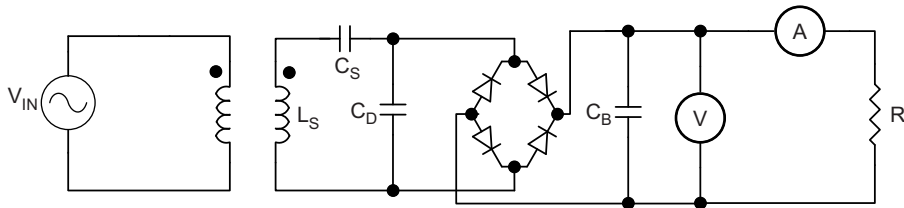

Figure 43. Load-Line Analysis Test Bench

Where:

- V_{IN} is a square-wave power source that should have a peak-to-peak operation of 19V.
- C_P is the primary series resonant capacitor (i.e. 100 nF for Type A1 coil).
- L_P is the primary coil of interest (i.e. Type A1).
- L_S is the secondary coil of interest.
- C_S is the series resonant capacitor chosen for the receiver coil under test.
- C_D is the parallel resonant capacitor chosen for the receiver coil under test.
- C_B is the bulk capacitor of the diode bridge (voltage rating should be at least 25 V and capacitance value of at least 10 μ F)
- V is a Kelvin connected voltage meter
- A is a series ammeter
- R_L is the load of interest

It is recommended that the diode bridge be constructed of Schottky diodes.

The test procedure is as follows

- Supply a 19V AC signal to L_P starting at a frequency of 210 kHz
- Measure the resulting rectified voltage from no load to the expected full load
- Repeat the above steps for lower frequencies (stopping at 110 kHz)

An example load-line analysis is shown in Figure 44:

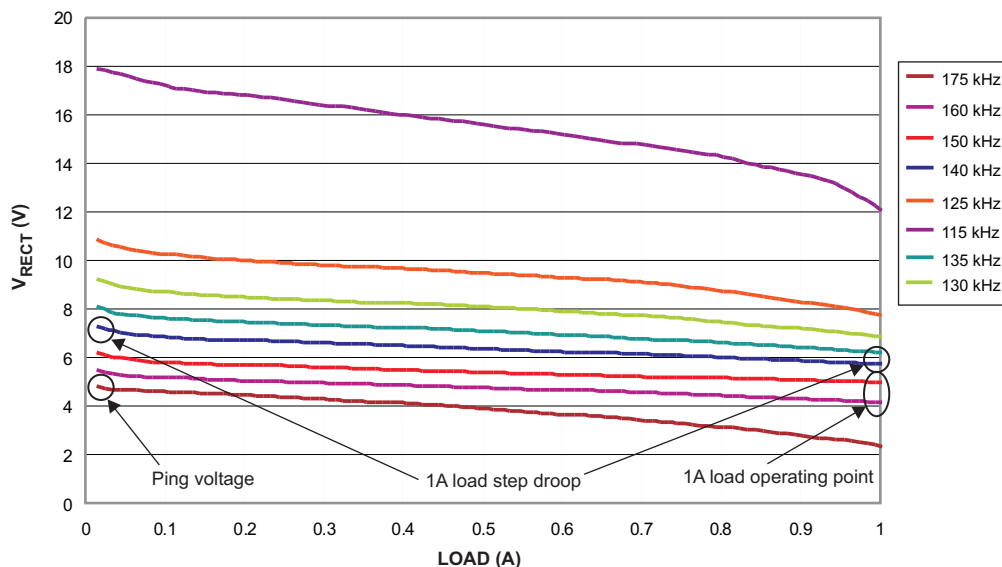

Figure 44. Example Load-Line Results

What this plot conveys about the operating point is that a specific load and rectifier target condition consequently results in a specific operating frequency (for the type A1 TX). For example, at 1 A the dynamic rectifier target is 5.15 V. Therefore, the operating frequency will be between 150kHz and 160kHz in the above example. This is an acceptable operating point. If the operating point ever falls outside the WPC frequency range (110kHz – 205kHz), the system will never converge and will become unstable.

In regards to transient analysis, there are two major points of interest:

1. Rectifier voltage at the ping frequency (175kHz).
2. Rectifier voltage droop from no load to full load at the constant operating point.

In this example, the ping voltage will be approximately 5 V. This is above the UVLO of the bq5101xB and; therefore, startup in the WPC system can be ensured. If the voltage is near or below the UVLO at this frequency, then startup in the WPC system may not occur.

If the max load step is 1 A, the droop in this example will be Approximately 1V with a voltage at 1 A of Approximately 5.5 V (140 kHz load-line). To analyze the droop locate the load-line that starts at 7 V at no-load. Follow this load-line to the max load expected and take the difference between the 7V no-load voltage and the full-load voltage at that constant frequency. Ensure that the full-load voltage at this constant frequency is above 5V. If it descends below 5V, the output of the power supply will also droop to this level. This type of transient response analysis is necessary due to the slow feedback response of the WPC system. This simulates the step response prior to the WPC system adjusting the operating point.

NOTE

Coupling between the primary and secondary coils will worsen with misalignment of the secondary coil. Therefore, it is recommended to re-analyze the load-lines at multiple misalignments to determine where, in planar space, the receiver will discontinue operation.

Recommended Rx coils can be found in [Table 7](#):

Table 7.

Manufacturer	Part Number	Dimensions	Ls	Ls'	Output Current Range	Application
TDK	WR-483250-15M2-G	48 x 32mm	10.4 μ H	12 μ H ⁽¹⁾	50-1000 mA	General 5V Power Supply
TDK	WR-383250-17M2-G	38 x 32mm	11.1 μ H	12.3 μ H ⁽¹⁾	50-1000 mA	Space limited 5V Power Supply
Vishay	IWAS-4832FF-50	48 x 32mm	10.8 μ H	12.5 μ H ⁽¹⁾	50-1000 mA	General 5V Power Supply
Mingstar	312-00012	48 x 32mm	10.8 μ H	12.9 μ H ⁽¹⁾	50-1000 mA	General 5V power Supply
Mingstar	312-00015	28 x 14mm	36.5 μ H	45 μ H ⁽²⁾	150-1000 mA	Space limited 5V Power Supply

- (1) Ls' measurements conducted with a standard battery behind the Rx coil assembly. This measurement is subject to change based on different battery sizes, placements, and casing material.
- (2) Battery not present behind the Rx coil assembly. Subject to drop in inductance depending on the placement of the battery.

It is recommended that all inductance measurements are repeated in the designers specific system as there are many influence on the final measurements.

Package Summary

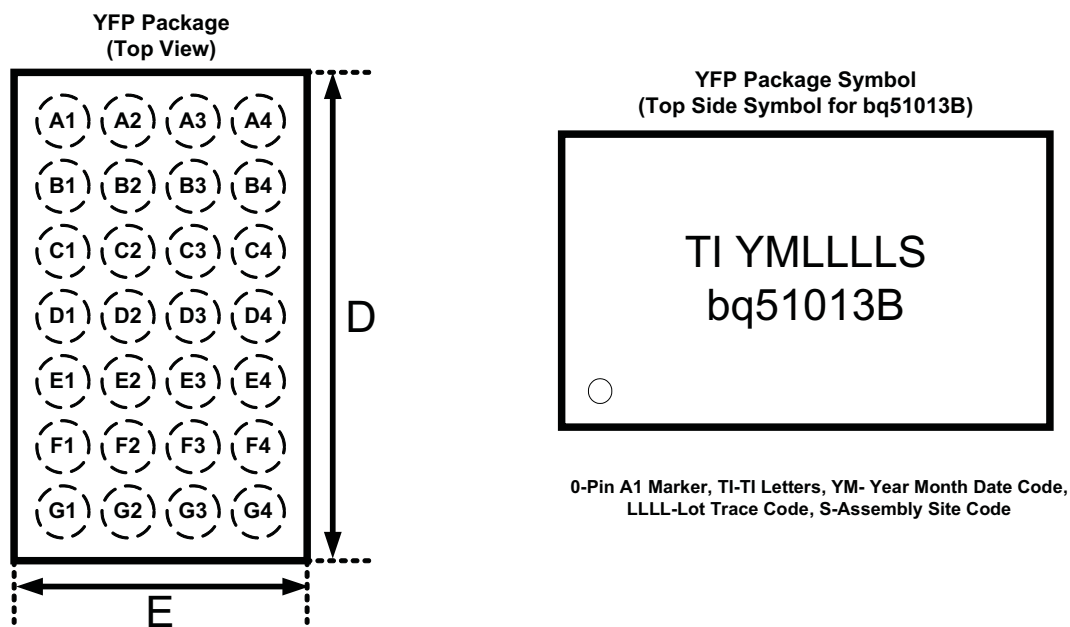

Figure 45. Chip Scale Packaging Dimensions

- D = 3.0mm ± 0.035mm
- E = 1.88mm ± 0.035mm

PACKAGING INFORMATION

Orderable Device	Status (1)	Package Type	Package Drawing	Pins	Package Qty	Eco Plan (2)	Lead/Ball Finish	MSL Peak Temp (3)	Op Temp (°C)	Top-Side Markings (4)	Samples
BQ51013BRHLR	ACTIVE	QFN	RHL	20	3000	Green (RoHS & no Sb/Br)	CU NIPDAU	Level-2-260C-1 YEAR		BQ51013B	Samples
BQ51013BRHLT	ACTIVE	QFN	RHL	20	250	Green (RoHS & no Sb/Br)	CU NIPDAU	Level-2-260C-1 YEAR		BQ51013B	Samples
BQ51013BYFPR	ACTIVE	DSBGA	YFP	28	3000	Green (RoHS & no Sb/Br)	SNAGCU	Level-1-260C-UNLIM		BQ51013B	Samples
BQ51013BYFPT	ACTIVE	DSBGA	YFP	28	250	Green (RoHS & no Sb/Br)	SNAGCU	Level-1-260C-UNLIM		BQ51013B	Samples

(1) The marketing status values are defined as follows:

ACTIVE: Product device recommended for new designs.

LIFEBUY: TI has announced that the device will be discontinued, and a lifetime-buy period is in effect.

NRND: Not recommended for new designs. Device is in production to support existing customers, but TI does not recommend using this part in a new design.

PREVIEW: Device has been announced but is not in production. Samples may or may not be available.

OBSOLETE: TI has discontinued the production of the device.

(2) Eco Plan - The planned eco-friendly classification: Pb-Free (RoHS), Pb-Free (RoHS Exempt), or Green (RoHS & no Sb/Br) - please check <http://www.ti.com/productcontent> for the latest availability information and additional product content details.

TBD: The Pb-Free/Green conversion plan has not been defined.

Pb-Free (RoHS): TI's terms "Lead-Free" or "Pb-Free" mean semiconductor products that are compatible with the current RoHS requirements for all 6 substances, including the requirement that lead not exceed 0.1% by weight in homogeneous materials. Where designed to be soldered at high temperatures, TI Pb-Free products are suitable for use in specified lead-free processes.

Pb-Free (RoHS Exempt): This component has a RoHS exemption for either 1) lead-based flip-chip solder bumps used between the die and package, or 2) lead-based die adhesive used between the die and leadframe. The component is otherwise considered Pb-Free (RoHS compatible) as defined above.

Green (RoHS & no Sb/Br): TI defines "Green" to mean Pb-Free (RoHS compatible), and free of Bromine (Br) and Antimony (Sb) based flame retardants (Br or Sb do not exceed 0.1% by weight in homogeneous material)

(3) MSL, Peak Temp. -- The Moisture Sensitivity Level rating according to the JEDEC industry standard classifications, and peak solder temperature.

(4) Only one of markings shown within the brackets will appear on the physical device.

Important Information and Disclaimer: The information provided on this page represents TI's knowledge and belief as of the date that it is provided. TI bases its knowledge and belief on information provided by third parties, and makes no representation or warranty as to the accuracy of such information. Efforts are underway to better integrate information from third parties. TI has taken and continues to take reasonable steps to provide representative and accurate information but may not have conducted destructive testing or chemical analysis on incoming materials and chemicals. TI and TI suppliers consider certain information to be proprietary, and thus CAS numbers and other limited information may not be available for release.

In no event shall TI's liability arising out of such information exceed the total purchase price of the TI part(s) at issue in this document sold by TI to Customer on an annual basis.

MECHANICAL DATA

RHL (R-PVQFN-N20)

PLASTIC QUAD FLATPACK NO-LEAD

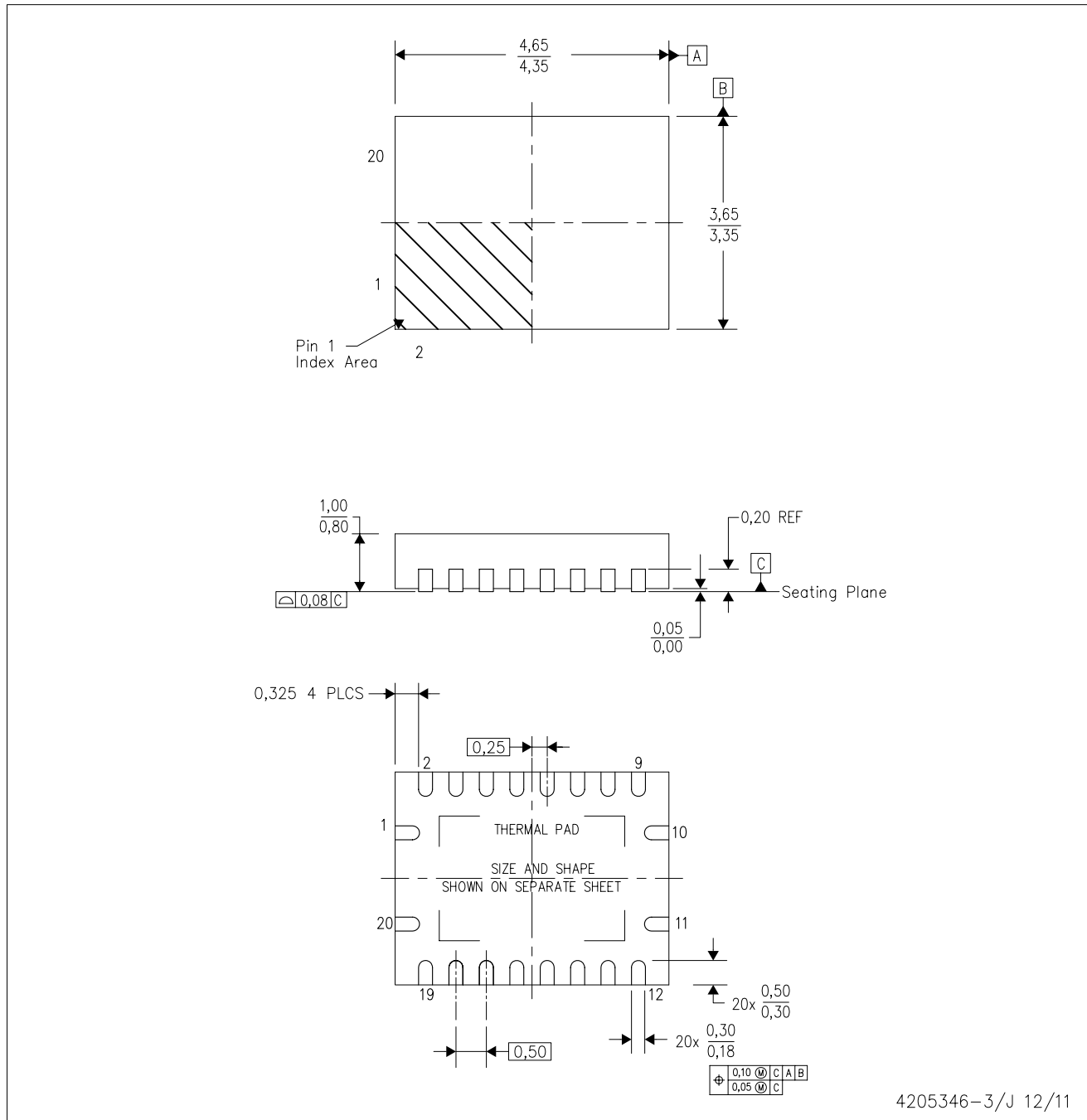

4205346-3/J 12/11

- NOTES:
- All linear dimensions are in millimeters. Dimensioning and tolerancing per ASME Y14.5M-1994.
 - This drawing is subject to change without notice.
 - QFN (Quad Flatpack No-Lead) Package configuration.
 - The package thermal pad must be soldered to the board for thermal and mechanical performance.
 - See the additional figure in the Product Data Sheet for details regarding the exposed thermal pad features and dimensions.

THERMAL PAD MECHANICAL DATA

RHL (S-PVQFN-N20)

PLASTIC QUAD FLATPACK NO-LEAD

THERMAL INFORMATION

This package incorporates an exposed thermal pad that is designed to be attached directly to an external heatsink. The thermal pad must be soldered directly to the printed circuit board (PCB). After soldering, the PCB can be used as a heatsink. In addition, through the use of thermal vias, the thermal pad can be attached directly to the appropriate copper plane shown in the electrical schematic for the device, or alternatively, can be attached to a special heatsink structure designed into the PCB. This design optimizes the heat transfer from the integrated circuit (IC).

For information on the Quad Flatpack No-Lead (QFN) package and its advantages, refer to Application Report, QFN/SON PCB Attachment, Texas Instruments Literature No. SLUA271. This document is available at www.ti.com.

The exposed thermal pad dimensions for this package are shown in the following illustration.

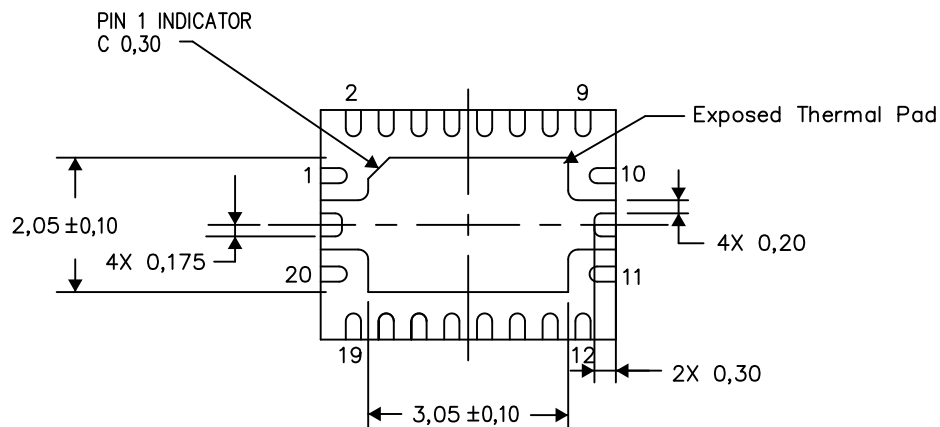

Bottom View

Exposed Thermal Pad Dimensions

4206363-3/M 08/12

NOTE: All linear dimensions are in millimeters

RHL (R-PVQFN-N20)

PLASTIC QUAD FLATPACK NO-LEAD

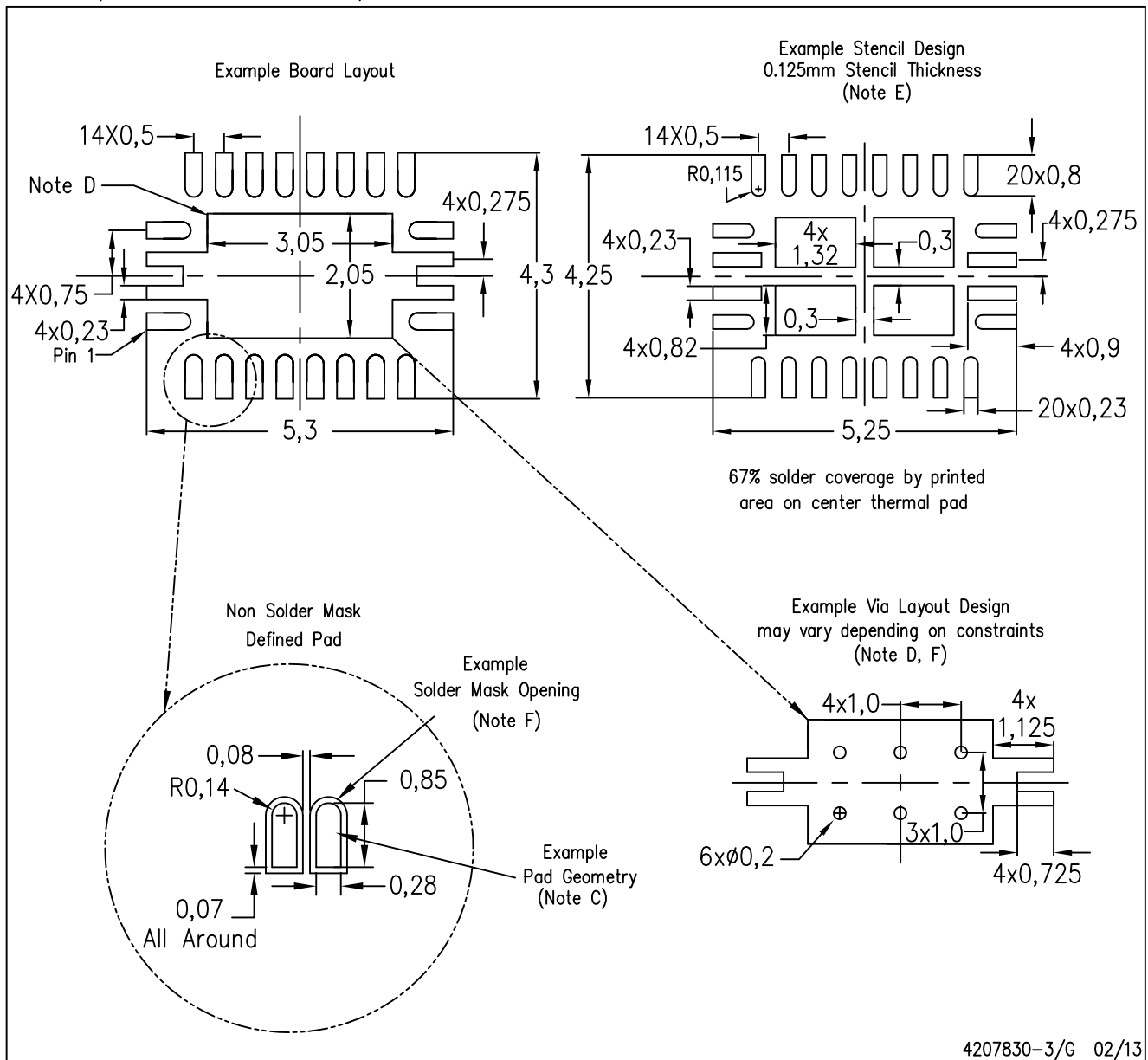

- NOTES:
- All linear dimensions are in millimeters.
 - This drawing is subject to change without notice.
 - Publication IPC-7351 is recommended for alternate designs.
 - This package is designed to be soldered to a thermal pad on the board. Refer to Application Note, Quad Flat-Pack Packages, Texas Instruments Literature No. SLUA271, and also the Product Data Sheets for specific thermal information, via requirements, and recommended board layout. These documents are available at www.ti.com <<http://www.ti.com>>.
 - Laser cutting apertures with trapezoidal walls and also rounding corners will offer better paste release. Customers should contact their board assembly site for stencil design recommendations. Refer to IPC 7525 for stencil design considerations.
 - Customers should contact their board fabrication site for minimum solder mask web tolerances between signal pads.

YFP (R-XBGA-N28)

DIE-SIZE BALL GRID ARRAY

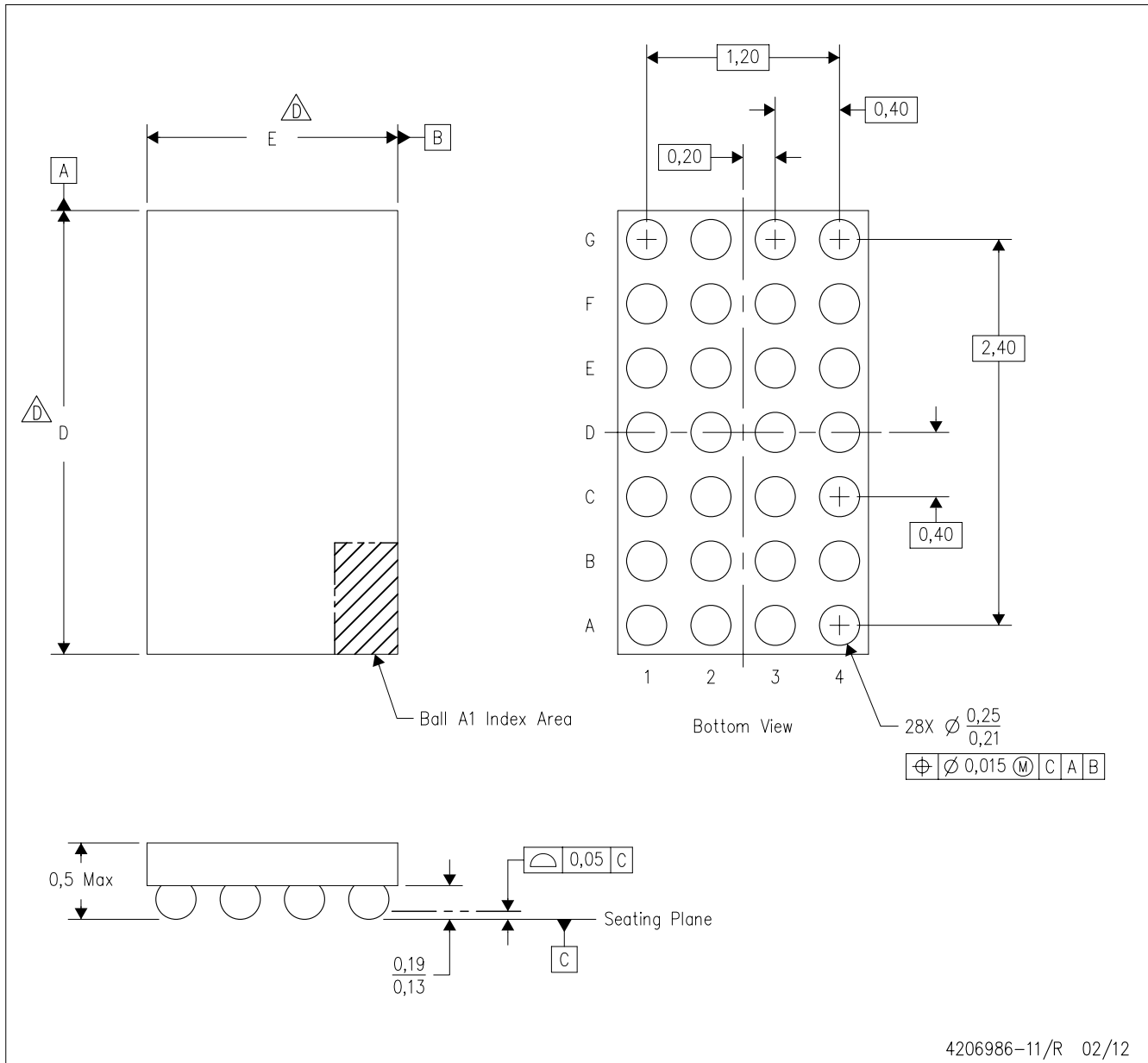

- NOTES:
- A. All linear dimensions are in millimeters. Dimensioning and tolerancing per ASME Y14.5M-1994.
 - B. This drawing is subject to change without notice.
 - C. NanoFree™ package configuration.
 - D. To determine the exact package size of a particular device, refer to the device datasheet or contact a local TI representative.
 - E. This package contains Pb-free balls.

NanoFree is a trademark of Texas Instruments

IMPORTANT NOTICE

Texas Instruments Incorporated and its subsidiaries (TI) reserve the right to make corrections, enhancements, improvements and other changes to its semiconductor products and services per JESD46, latest issue, and to discontinue any product or service per JESD48, latest issue. Buyers should obtain the latest relevant information before placing orders and should verify that such information is current and complete. All semiconductor products (also referred to herein as "components") are sold subject to TI's terms and conditions of sale supplied at the time of order acknowledgment.

TI warrants performance of its components to the specifications applicable at the time of sale, in accordance with the warranty in TI's terms and conditions of sale of semiconductor products. Testing and other quality control techniques are used to the extent TI deems necessary to support this warranty. Except where mandated by applicable law, testing of all parameters of each component is not necessarily performed.

TI assumes no liability for applications assistance or the design of Buyers' products. Buyers are responsible for their products and applications using TI components. To minimize the risks associated with Buyers' products and applications, Buyers should provide adequate design and operating safeguards.

TI does not warrant or represent that any license, either express or implied, is granted under any patent right, copyright, mask work right, or other intellectual property right relating to any combination, machine, or process in which TI components or services are used. Information published by TI regarding third-party products or services does not constitute a license to use such products or services or a warranty or endorsement thereof. Use of such information may require a license from a third party under the patents or other intellectual property of the third party, or a license from TI under the patents or other intellectual property of TI.

Reproduction of significant portions of TI information in TI data books or data sheets is permissible only if reproduction is without alteration and is accompanied by all associated warranties, conditions, limitations, and notices. TI is not responsible or liable for such altered documentation. Information of third parties may be subject to additional restrictions.

Resale of TI components or services with statements different from or beyond the parameters stated by TI for that component or service voids all express and any implied warranties for the associated TI component or service and is an unfair and deceptive business practice. TI is not responsible or liable for any such statements.

Buyer acknowledges and agrees that it is solely responsible for compliance with all legal, regulatory and safety-related requirements concerning its products, and any use of TI components in its applications, notwithstanding any applications-related information or support that may be provided by TI. Buyer represents and agrees that it has all the necessary expertise to create and implement safeguards which anticipate dangerous consequences of failures, monitor failures and their consequences, lessen the likelihood of failures that might cause harm and take appropriate remedial actions. Buyer will fully indemnify TI and its representatives against any damages arising out of the use of any TI components in safety-critical applications.

In some cases, TI components may be promoted specifically to facilitate safety-related applications. With such components, TI's goal is to help enable customers to design and create their own end-product solutions that meet applicable functional safety standards and requirements. Nonetheless, such components are subject to these terms.

No TI components are authorized for use in FDA Class III (or similar life-critical medical equipment) unless authorized officers of the parties have executed a special agreement specifically governing such use.

Only those TI components which TI has specifically designated as military grade or "enhanced plastic" are designed and intended for use in military/aerospace applications or environments. Buyer acknowledges and agrees that any military or aerospace use of TI components which have **not** been so designated is solely at the Buyer's risk, and that Buyer is solely responsible for compliance with all legal and regulatory requirements in connection with such use.

TI has specifically designated certain components as meeting ISO/TS16949 requirements, mainly for automotive use. In any case of use of non-designated products, TI will not be responsible for any failure to meet ISO/TS16949.

Products

Audio	www.ti.com/audio
Amplifiers	amplifier.ti.com
Data Converters	dataconverter.ti.com
DLP® Products	www.dlp.com
DSP	dsp.ti.com
Clocks and Timers	www.ti.com/clocks
Interface	interface.ti.com
Logic	logic.ti.com
Power Mgmt	power.ti.com
Microcontrollers	microcontroller.ti.com
RFID	www.ti-rfid.com
OMAP Applications Processors	www.ti.com/omap
Wireless Connectivity	www.ti.com/wirelessconnectivity

Applications

Automotive and Transportation	www.ti.com/automotive
Communications and Telecom	www.ti.com/communications
Computers and Peripherals	www.ti.com/computers
Consumer Electronics	www.ti.com/consumer-apps
Energy and Lighting	www.ti.com/energy
Industrial	www.ti.com/industrial
Medical	www.ti.com/medical
Security	www.ti.com/security
Space, Avionics and Defense	www.ti.com/space-avionics-defense
Video and Imaging	www.ti.com/video

TI E2E Community

e2e.ti.com