

bq40z50-R2 1-Series, 2-Series, 3-Series, and 4-Series Li-Ion Battery Pack Manager

1 Features

- Fully Integrated 1-Series, 2-Series, 3-Series, and 4-Series Li-Ion or Li-Polymer Cell Battery Pack Manager and Protection
- Next-Generation Patented Impedance Track™ Technology Accurately Measures Available Charge in Li-Ion and Li-Polymer Batteries
- High Side N-CH Protection FET Drive
- Integrated Cell Balancing While Charging or At Rest
- Suitable for Batteries Between 100 mAh and 29 Ah
- Full Array of Programmable Protection Features
 - Voltage
 - Current
 - Temperature
 - Charge Timeout
 - CHG/DSG FETs
 - AFE
- Sophisticated Charge Algorithms
 - JEITA
 - Enhanced Charging
 - Adaptive Charging
 - Cell Balancing
- Supports TURBO Mode 2.0
- Supports Battery Trip Point (BTP)
- Diagnostic Lifetime Data Monitor and Black Box Recorder
- LED Display
- Supports Two-Wire SMBus v1.1 Interface
- SHA-1 Authentication
- IATA Support
- Compact Package: 32-Lead QFN (RSM)

2 Applications

- Tablets
- Drones
- UPS/Battery Backup Systems
- Medical Equipment

3 Description

The bq40z50-R2 device, incorporating patented Impedance Track™ technology, is a fully integrated, single-chip, pack-based solution that provides a rich array of features for gas gauging, protection, and authentication for 1-series, 2-series, 3-series, and 4-series cell Li-Ion and Li-Polymer battery packs.

Using its integrated high-performance analog peripherals, the bq40z50-R2 device measures and maintains an accurate record of available capacity, voltage, current, temperature, and other critical parameters in Li-Ion or Li-Polymer batteries, and reports this information to the system host controller over an SMBus v1.1 compatible interface.

Device Information⁽¹⁾

PART NUMBER	PACKAGE	BODY SIZE (NOM)
bq40z50-R2	VQFN (32)	4.00 mm x 4.00 mm

(1) For all available packages, see the orderable addendum at the end of the data sheet.

Simplified Schematic

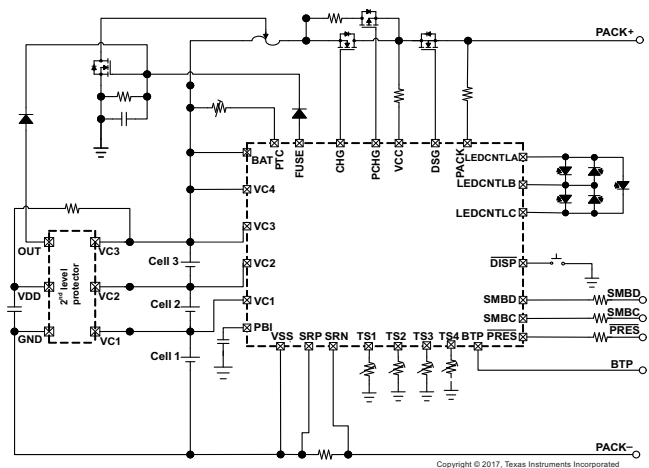

Copyright © 2017, Texas Instruments Incorporated



Table of Contents

1 Features	1	7.26 Low-Frequency Oscillator	14
2 Applications	1	7.27 Voltage Reference 1	15
3 Description	1	7.28 Voltage Reference 2	15
4 Revision History	2	7.29 Instruction Flash	15
5 Description (continued)	3	7.30 Data Flash	15
6 Pin Configuration and Functions	3	7.31 OCD, SCC, SCD1, SCD2 Current Protection Thresholds	16
7 Specifications	7	7.32 Timing Requirements: OCD, SCC, SCD1, SCD2 Current Protection Timing	16
7.1 Absolute Maximum Ratings	7	7.33 Timing Requirements: SMBus	17
7.2 ESD Ratings	7	7.34 Timing Requirements: SMBus XL	17
7.3 Recommended Operating Conditions	8	7.35 Typical Characteristics	19
7.4 Thermal Information	8	8 Detailed Description	22
7.5 Supply Current	8	8.1 Overview	22
7.6 Power Supply Control	9	8.2 Functional Block Diagram	22
7.7 AFE Power-On Reset	9	8.3 Feature Description	23
7.8 AFE Watchdog Reset and Wake Timer	9	8.4 Device Functional Modes	26
7.9 Current Wake Comparator	9	9 Applications and Implementation	27
7.10 VC1, VC2, VC3, VC4, BAT, PACK	10	9.1 Application Information	27
7.11 SMBD, SMBC	10	9.2 Typical Applications	28
7.12 $\overline{\text{PRES}}$, BTP_INT, $\overline{\text{DISP}}$	10	10 Power Supply Recommendations	39
7.13 LEDCNTLA, LEDCNTLB, LEDCNTLC	11	11 Layout	39
7.14 Coulomb Counter	11	11.1 Layout Guidelines	39
7.15 CC Digital Filter	11	11.2 Layout Example	41
7.16 ADC	11	12 Device and Documentation Support	43
7.17 ADC Digital Filter	12	12.1 Documentation Support	43
7.18 CHG, DSG FET Drive	12	12.2 Receiving Notification of Documentation Updates	43
7.19 PCHG FET Drive	13	12.3 Community Resources	43
7.20 FUSE Drive	13	12.4 Trademarks	43
7.21 Internal Temperature Sensor	13	12.5 Electrostatic Discharge Caution	43
7.22 TS1, TS2, TS3, TS4	13	12.6 Glossary	43
7.23 PTC, PTCEN	14	13 Mechanical, Packaging, and Orderable Information	43
7.24 Internal 1.8-V LDO	14		
7.25 High-Frequency Oscillator	14		

4 Revision History

NOTE: Page numbers for previous revisions may differ from page numbers in the current version.

Date	Revision	Notes
June 2017	*	Initial Release

5 Description (continued)

The bq40z50-R2 device supports TURBO Mode 2.0 by providing the available max power and max current to the host system. The device also supports Battery Trip Point to send a BTP interrupt signal to the host system at the preset state of charge thresholds.

The bq40z50-R2 provides software-based 1st- and 2nd-level safety protection against overvoltage, undervoltage, overcurrent, short-circuit current, overload, and overtemperature conditions, as well as other pack- and cell-related faults.

SHA-1 authentication, with secure memory for authentication keys, enables identification of genuine battery packs.

The compact 32-lead QFN package minimizes solution cost and size for smart batteries while providing maximum functionality and safety for battery gauging applications.

6 Pin Configuration and Functions

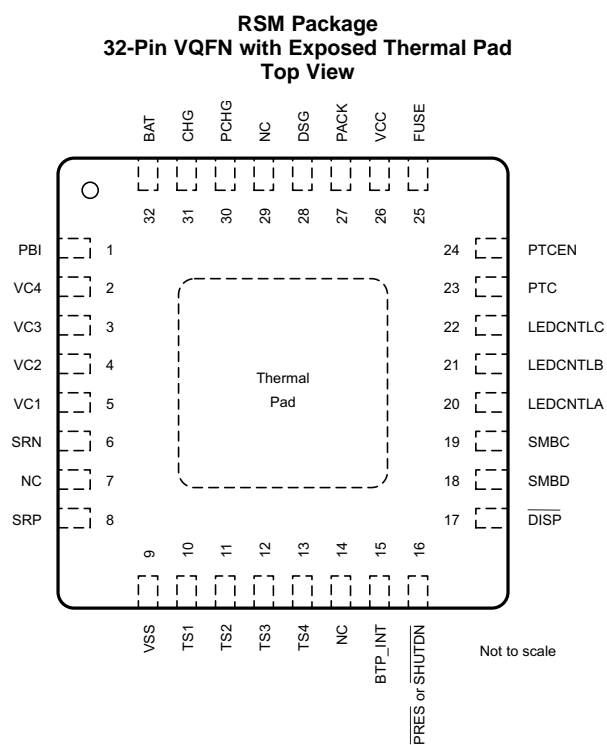

Pin Functions

PIN NUMBER	PIN NAME	TYPE	DESCRIPTION
1	PBI	P ⁽¹⁾	Power supply backup input pin
2	VC4	IA	Sense voltage input pin for the most positive cell, and balance current input for the most positive cell
3	VC3	IA	Sense voltage input pin for the second-most positive cell, balance current input for the second-most positive cell, and return balance current for the most positive cell
4	VC2	IA	Sense voltage input pin for the third-most positive cell, balance current input for the third-most positive cell, and return balance current for the second-most positive cell
5	VC1	IA	Sense voltage input pin for the least positive cell, balance current input for the least positive cell, and return balance current for the third-most positive cell

(1) P = Power Connection, O = Digital Output, AI = Analog Input, I = Digital Input, I/OD = Digital Input/Output

Pin Functions (continued)

PIN NUMBER	PIN NAME	TYPE	DESCRIPTION
6	SRN	I	Analog input pin connected to the internal coulomb counter peripheral for integrating a small voltage between SRP and SRN where SRP is the top of the sense resistor.
7	NC	—	Not internally connected
8	SRP	I	Analog input pin connected to the internal coulomb counter peripheral for integrating a small voltage between SRP and SRN where SRP is the top of the sense resistor.
9	VSS	P	Device ground
10	TS1	IA	Temperature sensor 1 thermistor input pin
11	TS2	IA	Temperature sensor 2 thermistor input pin
12	TS3	IA	Temperature sensor 3 thermistor input pin
13	TS4	IA	Temperature sensor 4 thermistor input pin
14	NC	—	Not internally connected
15	BTP_INT	O	Battery Trip Point (BTP) interrupt output
16	$\overline{\text{PRES}}$ or $\overline{\text{SHUTDN}}$	I	Host system present input for removable battery pack or emergency system shutdown input for embedded pack. A pullup is not required for this pin.
17	$\overline{\text{DISP}}$	—	Display control for LEDs
18	SMBD	I/OD	SMBus data pin
19	SMBC	I/OD	SMBus clock pin
20	LEDCNTLA	—	LED display segment that drives the external LEDs depending on the firmware configuration
21	LEDCNTLB	—	LED display segment that drives the external LEDs depending on the firmware configuration
22	LEDCNTLC	—	LED display segment that drives the external LEDs depending on the firmware configuration
23	PTC	IA	Safety PTC thermistor input pin. To disable, connect both PTC and PTCEN to VSS.
24	PTCEN	IA	Safety PTC thermistor enable input pin. Connect to BAT. To disable, connect both PTC and PTCEN to VSS.
25	FUSE	O	Fuse drive output pin. Connect to VSS if not used.
26	VCC	P	Secondary power supply input
27	PACK	IA	Pack sense input pin
28	DSG	O	NMOS Discharge FET drive output pin
29	NC	—	Not internally connected
30	PCHG	O	PMOS Precharge FET drive output pin
31	CHG	O	NMOS Charge FET drive output pin
32	BAT	P	Primary power supply input pin

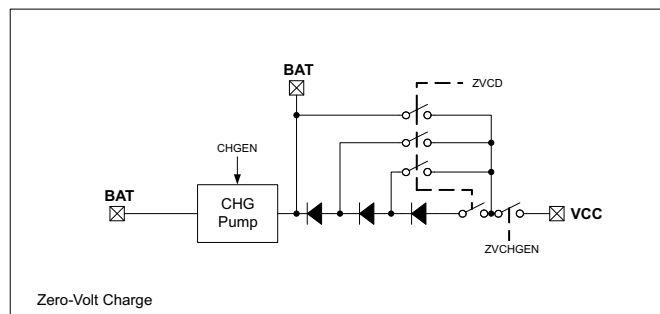
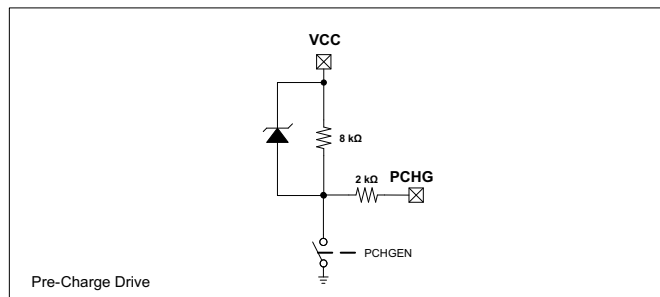
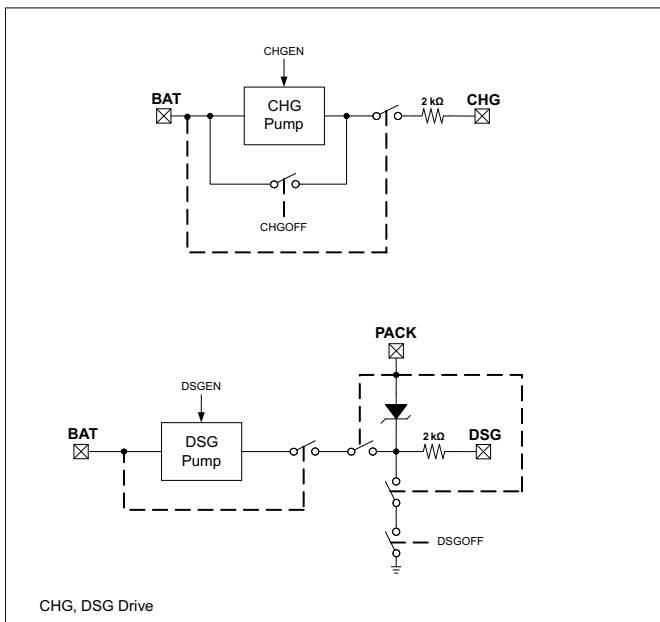
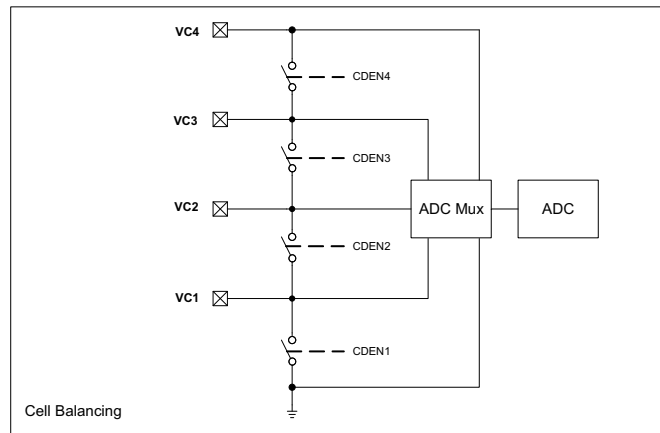
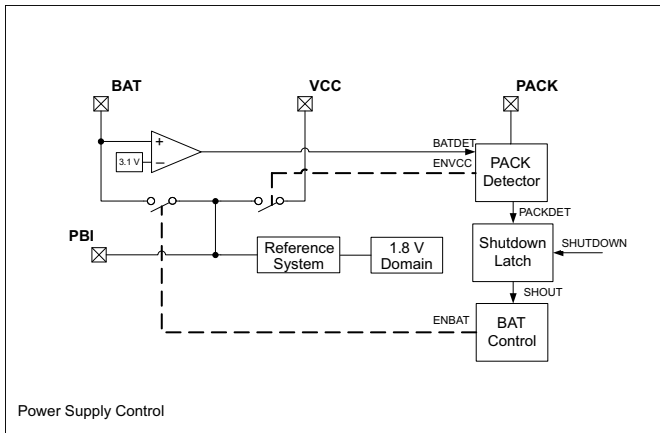

Figure 1. Pin Equivalent Diagram 1

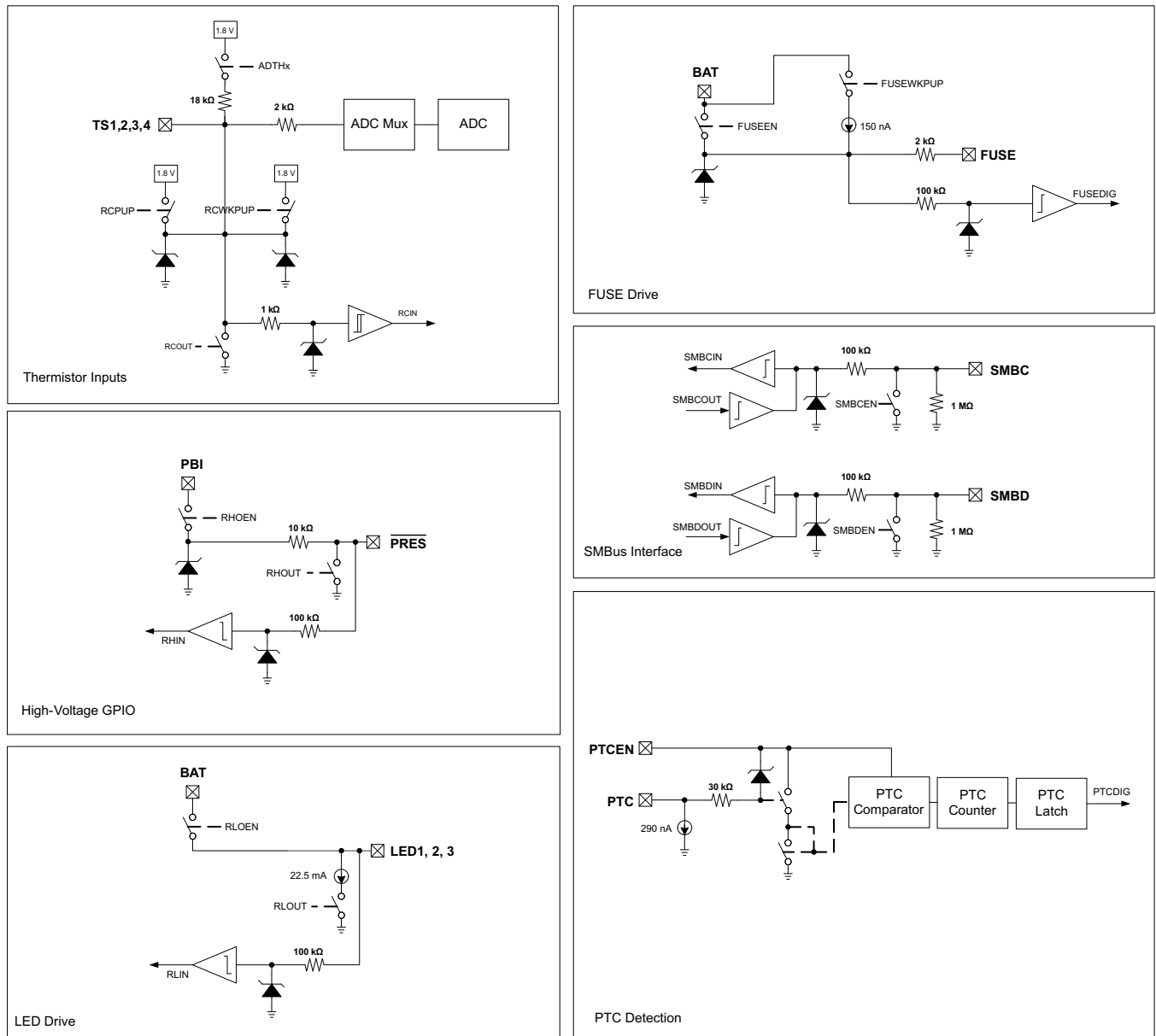

Figure 2. Pin Equivalent Diagram 2

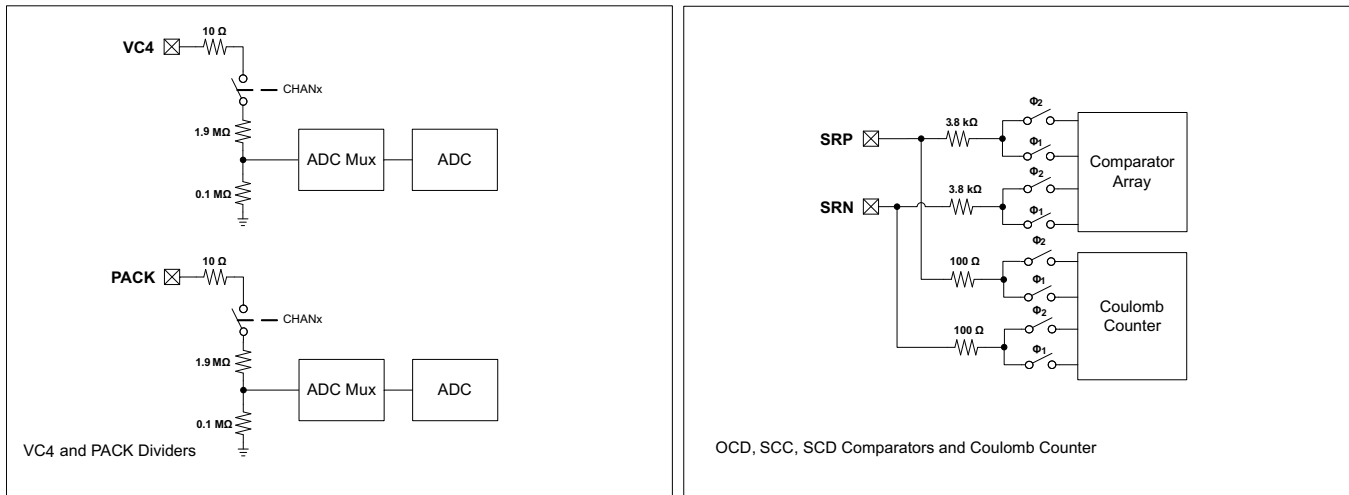

Figure 3. Pin Equivalent Diagram 3

7 Specifications

7.1 Absolute Maximum Ratings

Over-operating free-air temperature range (unless otherwise noted)⁽¹⁾

		MIN	MAX	UNIT
Supply voltage range, V _{CC}	BAT, VCC, PBI	-0.3	30	V
Input voltage range, V _{IN}	PACK, SMBC, SMBD, $\overline{\text{PRES}}$ or $\overline{\text{SHUTDN}}$, BTP_INT, $\overline{\text{DISP}}$	-0.3	30	V
	TS1, TS2, TS3, TS4	-0.3	V _{REG} + 0.3	V
	PTC, PTCEN, LEDCNTLA, LEDCNTLB, LEDCNTLC	-0.3	V _{BAT} + 0.3	V
	SRP, SRN	-0.3	0.3	V
	VC4	VC3 - 0.3	VC3 + 8.5, or VSS + 30	V
	VC3	VC2 - 0.3	VC2 + 8.5, or VSS + 30	V
Output voltage range, V _O	CHG, DSG	-0.3	32	
	PCHG, FUSE	-0.3	30	V
Maximum VSS current, I _{SS}			50	mA
Storage temperature, T _{STG}		-65	150	°C
Lead temperature (soldering, 10 s), T _{SOLDER}			300	°C

(1) Stresses beyond those listed under *absolute maximum ratings* may cause permanent damage to the device. These are stress ratings only, and functional operation of the device at these or any other conditions beyond those indicated under *recommended operating conditions* is not implied. Exposure to absolute-maximum-rated conditions for extended periods may affect device reliability.

7.2 ESD Ratings

		VALUE	UNIT
V _(ESD)	Electrostatic discharge	Human-body model (HBM), per ANSI/ESDA/JEDEC JS-001 ⁽¹⁾	±2000
		Charged-device model (CDM), per JEDEC specification JESD22-C101 ⁽²⁾	±500

(1) JEDEC document JEP155 states that 500-V HBM allows safe manufacturing with a standard ESD control process.

(2) JEDEC document JEP157 states that 250-V CDM allows safe manufacturing with a standard ESD control process.

7.3 Recommended Operating Conditions

Typical values stated where $T_A = 25^\circ\text{C}$ and $V_{CC} = 14.4\text{ V}$, Min/Max values stated where $T_A = -40^\circ\text{C}$ to 85°C and $V_{CC} = 2.2\text{ V}$ to 26 V (unless otherwise noted)

			MIN	NOM	MAX	UNIT
V_{CC}	Supply voltage	BAT, VCC, PBI	2.2		26	V
$V_{SHUTDOWN-}$	Shutdown voltage	$V_{PACK} < V_{SHUTDOWN-}$	1.8	2.0	2.2	V
$V_{SHUTDOWN+}$	Start-up voltage	$V_{PACK} > V_{SHUTDOWN-} + V_{HYS}$	2.05	2.25	2.45	V
V_{HYS}	Shutdown voltage hysteresis	$V_{SHUTDOWN+} - V_{SHUTDOWN-}$		250		mV
V_{IN}	Input voltage range	PACK, SMBC, SMBD, $\overline{\text{PRES}}$, BTP_IN, $\overline{\text{DISP}}$			26	V
		TS1, TS2, TS3, TS4			V_{REG}	
		PTC, PTCEN, LEDCNTLA, LEDCNTLB, LEDCNTLC			V_{BAT}	
		SRP, SRN	-0.2		0.2	
		VC4	V_{VC3}		$V_{VC3} + 5$	
		VC3	V_{VC2}		$V_{VC2} + 5$	
		VC2	V_{VC1}		$V_{VC1} + 5$	
	VC1	V_{VSS}		$V_{VSS} + 5$		
V_O	Output voltage range	CHG, DSG, PCHG, FUSE			26	V
C_{PBI}	External PBI capacitor		2.2			μF
T_{OPR}	Operating temperature		-40		85	$^\circ\text{C}$

7.4 Thermal Information

THERMAL METRIC ⁽¹⁾		bq40z50-R2		UNIT
		RSM (QFN)		
		32 PINS		
$R_{\theta JA, \text{High K}}$	Junction-to-ambient thermal resistance	47.4		$^\circ\text{C/W}$
$R_{\theta JC(\text{top})}$	Junction-to-case(top) thermal resistance	40.3		$^\circ\text{C/W}$
$R_{\theta JB}$	Junction-to-board thermal resistance	14.7		$^\circ\text{C/W}$
ψ_{JT}	Junction-to-top characterization parameter	0.8		$^\circ\text{C/W}$
ψ_{JB}	Junction-to-board characterization parameter	14.4		$^\circ\text{C/W}$
$R_{\theta JC(\text{bottom})}$	Junction-to-case(bottom) thermal resistance	3.8		$^\circ\text{C/W}$

(1) For more information about traditional and new thermal metrics, see the *Semiconductor and IC Package Thermal Metrics* application report, [SPRA953](#).

7.5 Supply Current

Typical values stated where $T_A = 25^\circ\text{C}$ and $V_{CC} = 14.4\text{ V}$, Min/Max values stated where $T_A = -40^\circ\text{C}$ to 85°C and $V_{CC} = 2.2\text{ V}$ to 20 V (unless otherwise noted)

PARAMETER		TEST CONDITIONS	MIN	TYP	MAX	UNIT
I_{NORMAL}	NORMAL mode	CHG on, DSG on, no Flash write		336		μA
I_{SLEEP}	SLEEP mode	CHG off, DSG on, no SBS communication		75		μA
		CHG off, DSG off, no SBS communication		52		
$I_{SHUTDOWN}$	SHUTDOWN mode			1.6		μA

7.6 Power Supply Control

Typical values stated where $T_A = 25^\circ\text{C}$ and $V_{CC} = 14.4\text{ V}$, Min/Max values stated where $T_A = -40^\circ\text{C}$ to 85°C and $V_{CC} = 2.2\text{ V}$ to 26 V (unless otherwise noted)

PARAMETER		TEST CONDITIONS	MIN	TYP	MAX	UNIT
$V_{\text{SWITCHOVER-}}$	BAT to V_{CC} switchover voltage	$V_{\text{BAT}} < V_{\text{SWITCHOVER-}}$	1.95	2.1	2.2	V
$V_{\text{SWITCHOVER+}}$	V_{CC} to BAT switchover voltage	$V_{\text{BAT}} > V_{\text{SWITCHOVER-}} + V_{\text{HYS}}$	2.9	3.1	3.25	V
V_{HYS}	Switchover voltage hysteresis	$V_{\text{SWITCHOVER+}} - V_{\text{SWITCHOVER-}}$		1000		mV
I_{LKG}	Input Leakage current	BAT pin, BAT = 0 V, $V_{CC} = 25\text{ V}$, PACK = 25 V			1	μA
		PACK pin, BAT = 25 V, $V_{CC} = 0\text{ V}$, PACK = 0 V			1	
		BAT and PACK terminals, BAT = 0 V, $V_{CC} = 0\text{ V}$, PACK = 0 V, PBI = 25 V			1	

7.7 AFE Power-On Reset

Typical values stated where $T_A = 25^\circ\text{C}$ and $V_{CC} = 14.4\text{ V}$, Min/Max values stated where $T_A = -40^\circ\text{C}$ to 85°C and $V_{CC} = 2.2\text{ V}$ to 26 V (unless otherwise noted)

PARAMETER		TEST CONDITIONS	MIN	TYP	MAX	UNIT
$V_{\text{REGIT-}}$	Negative-going voltage input	V_{REG}	1.51	1.55	1.59	V
V_{HYS}	Power-on reset hysteresis	$V_{\text{REGIT+}} - V_{\text{REGIT-}}$	70	100	130	mV
t_{RST}	Power-on reset time		200	300	400	μs

7.8 AFE Watchdog Reset and Wake Timer

Typical values stated where $T_A = 25^\circ\text{C}$ and $V_{CC} = 14.4\text{ V}$, Min/Max values stated where $T_A = -40^\circ\text{C}$ to 85°C and $V_{CC} = 2.2\text{ V}$ to 26 V (unless otherwise noted)

PARAMETER		TEST CONDITIONS	MIN	TYP	MAX	UNIT
t_{WDT}	AFE watchdog timeout	$t_{\text{WDT}} = 500$	372	500	628	ms
		$t_{\text{WDT}} = 1000$	744	1000	1256	
		$t_{\text{WDT}} = 2000$	1488	2000	2512	
		$t_{\text{WDT}} = 4000$	2976	4000	5024	
t_{WAKE}	AFE wake timer	$t_{\text{WAKE}} = 250$	186	250	314	ms
		$t_{\text{WAKE}} = 500$	372	500	628	
		$t_{\text{WAKE}} = 1000$	744	1000	1256	
		$t_{\text{WAKE}} = 512$	1488	2000	2512	
t_{FETOFF}	FET off delay after reset	$t_{\text{FETOFF}} = 512$	409	512	614	ms

7.9 Current Wake Comparator

Typical values stated where $T_A = 25^\circ\text{C}$ and $V_{CC} = 14.4\text{ V}$, Min/Max values stated where $T_A = -40^\circ\text{C}$ to 85°C and $V_{CC} = 2.2\text{ V}$ to 26 V (unless otherwise noted)

PARAMETER		TEST CONDITIONS	MIN	TYP	MAX	UNIT
V_{WAKE}	Wake voltage threshold	$V_{\text{WAKE}} = \pm 0.625\text{ mV}$	± 0.3	± 0.625	± 0.9	mV
		$V_{\text{WAKE}} = \pm 1.25\text{ mV}$	± 0.6	± 1.25	± 1.8	
		$V_{\text{WAKE}} = \pm 2.5\text{ mV}$	± 1.2	± 2.5	± 3.6	
		$V_{\text{WAKE}} = \pm 5\text{ mV}$	± 2.4	± 5.0	± 7.2	
$V_{\text{WAKE(DRIFT)}}$	Temperature drift of V_{WAKE} accuracy			0.5%	$^\circ\text{C}$	

Current Wake Comparator (continued)

Typical values stated where $T_A = 25^\circ\text{C}$ and $V_{CC} = 14.4\text{ V}$, Min/Max values stated where $T_A = -40^\circ\text{C}$ to 85°C and $V_{CC} = 2.2\text{ V}$ to 26 V (unless otherwise noted)

PARAMETER	TEST CONDITIONS	MIN	TYP	MAX	UNIT
t_{WAKE}	Time from application of current to wake interrupt			700	μs
$t_{\text{WAKE(SU)}}$	Wake comparator startup time		500	1000	μs

7.10 VC1, VC2, VC3, VC4, BAT, PACK

Typical values stated where $T_A = 25^\circ\text{C}$ and $V_{CC} = 14.4\text{ V}$, Min/Max values stated where $T_A = -40^\circ\text{C}$ to 85°C and $V_{CC} = 2.2\text{ V}$ to 26 V (unless otherwise noted)

PARAMETER	TEST CONDITIONS	MIN	TYP	MAX	UNIT			
K	Scaling factor	VC1–VSS, VC2–VC1, VC3–VC2, VC4–VC3	0.1980	0.2000	0.2020	—		
		BAT–VSS, PACK–VSS	0.049	0.050	0.051			
		V_{REF2}	0.490	0.500	0.510			
V_{IN}	Input voltage range	VC1–VSS, VC2–VC1, VC3–VC2, VC4–VC3	–0.2		5	V		
		BAT–VSS, PACK–VSS	–0.2		20			
I_{LKG}	Input leakage current	VC1, VC2, VC3, VC4, cell balancing off, cell detach detection off, ADC multiplexer off			1	μA		
R_{CB}	Internal cell balance resistance	$R_{\text{DS(ON)}}$ for internal FET switch at $2\text{ V} < V_{\text{DS}} < 4\text{ V}$			200	Ω		
I_{CD}	Internal cell detach check current	$V_{\text{Cx}} > V_{\text{SS}} + 0.8\text{ V}$			30	50	70	μA

7.11 SMBD, SMBC

Typical values stated where $T_A = 25^\circ\text{C}$ and $V_{CC} = 14.4\text{ V}$, Min/Max values stated where $T_A = -40^\circ\text{C}$ to 85°C and $V_{CC} = 2.2\text{ V}$ to 26 V (unless otherwise noted)

PARAMETER	TEST CONDITIONS	MIN	TYP	MAX	UNIT		
V_{IH}	Input voltage high	SMBC, SMBD, $V_{\text{REG}} = 1.8\text{ V}$			1.3	V	
V_{IL}	Input voltage low	SMBC, SMBD, $V_{\text{REG}} = 1.8\text{ V}$				0.8	V
V_{OL}	Output low voltage	SMBC, SMBD, $V_{\text{REG}} = 1.8\text{ V}$, $I_{\text{OL}} = 1.5\text{ mA}$				0.4	V
C_{IN}	Input capacitance				5	μF	
I_{LKG}	Input leakage current					1	μA
R_{PD}	Pulldown resistance	0.7	1.0	1.3		$\text{M}\Omega$	

7.12 $\overline{\text{PRES}}$, $\overline{\text{BTP_INT}}$, $\overline{\text{DISP}}$

Typical values stated where $T_A = 25^\circ\text{C}$ and $V_{CC} = 14.4\text{ V}$, Min/Max values stated where $T_A = -40^\circ\text{C}$ to 85°C and $V_{CC} = 2.2\text{ V}$ to 26 V (unless otherwise noted)

PARAMETER	TEST CONDITIONS	MIN	TYP	MAX	UNIT		
V_{IH}	High-level input				1.3	V	
V_{IL}	Low-level input					0.55	V
V_{OH}	Output voltage high	$V_{\text{BAT}} > 5.5\text{ V}$, $I_{\text{OH}} = -0\text{ }\mu\text{A}$			3.5	V	
		$V_{\text{BAT}} > 5.5\text{ V}$, $I_{\text{OH}} = -10\text{ }\mu\text{A}$			1.8		
V_{OL}	Output voltage low	$I_{\text{OL}} = 1.5\text{ mA}$				0.4	V
C_{IN}	Input capacitance				5	μF	
I_{LKG}	Input leakage current					1	μA
R_{O}	Output reverse resistance	Between $\overline{\text{PRES}}$ or $\overline{\text{BTP_INT}}$ or $\overline{\text{DISP}}$ and PBI			8	$\text{k}\Omega$	

7.13 LEDCNTLA, LEDCNTLB, LEDCNTLC

Typical values stated where $T_A = 25^\circ\text{C}$ and $V_{CC} = 14.4\text{ V}$, Min/Max values stated where $T_A = -40^\circ\text{C}$ to 85°C and $V_{CC} = 2.2\text{ V}$ to 26 V (unless otherwise noted)

PARAMETER	TEST CONDITIONS	MIN	TYP	MAX	UNIT
V_{IH}	High-level input	1.45			V
V_{IL}	Low-level input			0.55	V
V_{OH}	Output voltage high $V_{BAT} > 3.0\text{ V}$, $I_{OH} = -22.5\text{ mA}$	$V_{BAT} - 1.6$			V
V_{OL}	Output voltage low $I_{OL} = 1.5\text{ mA}$			0.4	V
I_{SC}	High level output current protection	-30	-45	-60	mA
I_{OL}	Low level output current $V_{BAT} > 3.0\text{ V}$, $V_{OH} = 0.4\text{ V}$	15.75	22.5	29.25	mA
$I_{LEDCNTLX}$	Current matching between LEDCNTLX $V_{BAT} = V_{LEDCNTLX} + 2.5\text{ V}$		$\pm 1\%$		
C_{IN}	Input capacitance		20		pF
I_{LKG}	Input leakage current			1	μA
$f_{LEDCNTLX}$	Frequency of LED pattern		124		Hz

7.14 Coulomb Counter

Typical values stated where $T_A = 25^\circ\text{C}$ and $V_{CC} = 14.4\text{ V}$, Min/Max values stated where $T_A = -40^\circ\text{C}$ to 85°C and $V_{CC} = 2.2\text{ V}$ to 26 V (unless otherwise noted)

PARAMETER	TEST CONDITIONS	MIN	TYP	MAX	UNIT
Input voltage range		-0.1		0.1	V
Full scale range		$-V_{REF1}/10$		$V_{REF1}/10$	V
Integral nonlinearity ⁽¹⁾	16-bit, best fit over input voltage range		± 5.2	± 22.3	LSB
Offset error	16-bit, Post-calibration		± 5	± 10	μV
Offset error drift	15-bit + sign, Post-calibration		0.2	0.3	$\mu\text{V}/^\circ\text{C}$
Gain error	15-bit + sign, over input voltage range		$\pm 0.2\%$	$\pm 0.8\%$	FSR
Gain error drift	15-bit + sign, over input voltage range			150	PPM/ $^\circ\text{C}$
Effective input resistance		2.5			$\text{M}\Omega$

(1) $1\text{ LSB} = V_{REF1}/(10 \times 2^N) = 1.215/(10 \times 2^{15}) = 3.71\text{ }\mu\text{V}$

7.15 CC Digital Filter

Typical values stated where $T_A = 25^\circ\text{C}$ and $V_{CC} = 14.4\text{ V}$, Min/Max values stated where $T_A = -40^\circ\text{C}$ to 85°C and $V_{CC} = 2.2\text{ V}$ to 26 V (unless otherwise noted)

PARAMETER	TEST CONDITIONS	MIN	TYP	MAX	UNIT
Conversion time	Single conversion		250		ms
Effective resolution	Single conversion	15			Bits

7.16 ADC

Typical values stated where $T_A = 25^\circ\text{C}$ and $V_{CC} = 14.4\text{ V}$, Min/Max values stated where $T_A = -40^\circ\text{C}$ to 85°C and $V_{CC} = 2.2\text{ V}$ to 26 V (unless otherwise noted)

PARAMETER	TEST CONDITIONS	MIN	TYP	MAX	UNIT
Input voltage range	Internal reference (V_{REF1})	-0.2		1	V
	External reference (V_{REG})	-0.2	$0.8 \times V_{REG}$		
Full scale range	$V_{FS} = V_{REF1}$ or V_{REG}	$-V_{FS}$		V_{FS}	V
Integral nonlinearity ⁽¹⁾	16-bit, best fit, -0.1 V to $0.8 \times V_{REF1}$			± 6.6	LSB
	16-bit, best fit, -0.2 V to -0.1 V			± 13.1	

(1) $1\text{ LSB} = V_{REF1}/(2^N) = 1.225/(2^{15}) = 37.4\text{ }\mu\text{V}$ (when $t_{CONV} = 31.25\text{ ms}$)

ADC (continued)

Typical values stated where $T_A = 25^\circ\text{C}$ and $V_{CC} = 14.4\text{ V}$, Min/Max values stated where $T_A = -40^\circ\text{C}$ to 85°C and $V_{CC} = 2.2\text{ V}$ to 26 V (unless otherwise noted)

PARAMETER	TEST CONDITIONS	MIN	TYP	MAX	UNIT
Offset error ⁽²⁾	16-bit, Post-calibration, $V_{FS} = V_{REF1}$		±67	±157	μV
Offset error drift	16-bit, Post-calibration, $V_{FS} = V_{REF1}$		0.6	3	μV/°C
Gain error	16-bit, -0.1 V to $0.8 \times V_{FS}$		±0.2%	±0.8%	FSR
Gain error drift	16-bit, -0.1 V to $0.8 \times V_{FS}$			150	PPM/°C
Effective input resistance		8			MΩ

(2) For $VC1-VSS$, $VC2-VC1$, $VC3-VC2$, $VC4-VC3$, $VC4-VSS$, $PACK-VSS$, and $V_{REF1}/2$, the offset error is multiplied by $(1/\text{ADC multiplexer scaling factor (K)})$.

7.17 ADC Digital Filter

Typical values stated where $T_A = 25^\circ\text{C}$ and $V_{CC} = 14.4\text{ V}$, Min/Max values stated where $T_A = -40^\circ\text{C}$ to 85°C and $V_{CC} = 2.2\text{ V}$ to 26 V (unless otherwise noted)

PARAMETER	TEST CONDITIONS	MIN	TYP	MAX	UNIT
Conversion time	Single conversion		31.25		ms
	Single conversion		15.63		
	Single conversion		7.81		
	Single conversion		1.95		
Resolution	No missing codes	16			Bits
Effective resolution	With sign, $t_{CONV} = 31.25\text{ ms}$	14	15		Bits
	With sign, $t_{CONV} = 15.63\text{ ms}$	13	14		
	With sign, $t_{CONV} = 7.81\text{ ms}$	11	12		
	With sign, $t_{CONV} = 1.95\text{ ms}$	9	10		

7.18 CHG, DSG FET Drive

Typical values stated where $T_A = 25^\circ\text{C}$ and $V_{CC} = 14.4\text{ V}$, Min/Max values stated where $T_A = -40^\circ\text{C}$ to 85°C and $V_{CC} = 2.2\text{ V}$ to 26 V (unless otherwise noted)

PARAMETER	TEST CONDITIONS	MIN	TYP	MAX	UNIT
Output voltage ratio	$\text{Ratio}_{DSG} = (V_{DSG} - V_{BAT})/V_{BAT}$, $2.2\text{ V} < V_{BAT} < 4.92\text{ V}$, $10\text{ M}\Omega$ between PACK and DSG	2.133	2.333	2.433	—
	$\text{Ratio}_{CHG} = (V_{CHG} - V_{BAT})/V_{BAT}$, $2.2\text{ V} < V_{BAT} < 4.92\text{ V}$, $10\text{ M}\Omega$ between BAT and CHG	2.133	2.333	2.433	
$V_{(FETON)}$	Output voltage, CHG and DSG on $V_{DSG(ON)} = V_{DSG} - V_{BAT}$, $V_{BAT} \geq 4.92\text{ V}$, $10\text{ M}\Omega$ between PACK and DSG, $V_{BAT} = 18\text{ V}$	10.5	11.5	12	V
	$V_{CHG(ON)} = V_{CHG} - V_{BAT}$, $V_{BAT} \geq 4.92\text{ V}$, $10\text{ M}\Omega$ between BAT and CHG, $V_{BAT} = 18\text{ V}$	10.5	11.5	12	
$V_{(FETOFF)}$	Output voltage, CHG and DSG off $V_{DSG(OFF)} = V_{DSG} - V_{PACK}$, $10\text{ M}\Omega$ between PACK and DSG	-0.4		0.4	V
	$V_{CHG(OFF)} = V_{CHG} - V_{BAT}$, $10\text{ M}\Omega$ between BAT and CHG	-0.4		0.4	
t_R	Rise time V_{DSG} from 0% to 35% $V_{DSG(ON)(TYP)}$, $V_{BAT} \geq 2.2\text{ V}$, $C_L = 4.7\text{ nF}$ between DSG and PACK, $5.1\text{ k}\Omega$ between DSG and C_L , $10\text{ M}\Omega$ between PACK and DSG		200	500	μs
	V_{CHG} from 0% to 35% $V_{CHG(ON)(TYP)}$, $V_{BAT} \geq 2.2\text{ V}$, $C_L = 4.7\text{ nF}$ between CHG and BAT, $5.1\text{ k}\Omega$ between CHG and C_L , $10\text{ M}\Omega$ between BAT and CHG		200	500	
t_F	Fall time V_{DSG} from $V_{DSG(ON)(TYP)}$ to 1 V , $V_{BAT} \geq 2.2\text{ V}$, $C_L = 4.7\text{ nF}$ between DSG and PACK, $5.1\text{ k}\Omega$ between DSG and C_L , $10\text{ M}\Omega$ between PACK and DSG		40	300	μs
	V_{CHG} from $V_{CHG(ON)(TYP)}$ to 1 V , $V_{BAT} \geq 2.2\text{ V}$, $C_L = 4.7\text{ nF}$ between CHG and BAT, $5.1\text{ k}\Omega$ between CHG and C_L , $10\text{ M}\Omega$ between BAT and CHG		40	200	

7.19 PCHG FET Drive

Typical values stated where $T_A = 25^\circ\text{C}$ and $V_{CC} = 14.4\text{ V}$, Min/Max values stated where $T_A = -40^\circ\text{C}$ to 85°C and $V_{CC} = 2.2\text{ V}$ to 26 V (unless otherwise noted)

PARAMETER		TEST CONDITIONS	MIN	TYP	MAX	UNIT
$V_{(\text{FETON})}$	Output voltage, PCHG on	$V_{\text{PCHG(ON)}} = V_{\text{VCC}} - V_{\text{PCHG}}$, 10 M Ω between V_{CC} and PCHG	6	7	8	V
$V_{(\text{FETOFF})}$	Output voltage, PCHG off	$V_{\text{PCHG(OFF)}} = V_{\text{VCC}} - V_{\text{PCHG}}$, 10 M Ω between V_{CC} and PCHG	-0.4		0.4	V
t_R	Rise time	V_{PCHG} from 10% to 90% $V_{\text{PCHG(ON)(TYP)}}$, $V_{\text{VCC}} \geq 8\text{ V}$, $C_L = 4.7\text{ nF}$ between PCHG and V_{CC} , 5.1 k Ω between PCHG and C_L , 10 M Ω between V_{CC} and CHG		40	200	μs
t_F	Fall time	V_{PCHG} from 90% to 10% $V_{\text{PCHG(ON)(TYP)}}$, $V_{\text{VCC}} \geq 8\text{ V}$, $C_L = 4.7\text{ nF}$ between PCHG and V_{CC} , 5.1 k Ω between PCHG and C_L , 10 M Ω between V_{CC} and CHG		40	200	μs

7.20 FUSE Drive

Typical values stated where $T_A = 25^\circ\text{C}$ and $V_{CC} = 14.4\text{ V}$, Min/Max values stated where $T_A = -40^\circ\text{C}$ to 85°C and $V_{CC} = 2.2\text{ V}$ to 26 V (unless otherwise noted)

PARAMETER		TEST CONDITIONS	MIN	TYP	MAX	UNIT
V_{OH}	Output voltage high	$V_{\text{BAT}} \geq 8\text{ V}$, $C_L = 1\text{ nF}$, $I_{\text{AFE FUSE}} = 0\text{ }\mu\text{A}$	6	7	8.65	V
		$V_{\text{BAT}} < 8\text{ V}$, $C_L = 1\text{ nF}$, $I_{\text{AFE FUSE}} = 0\text{ }\mu\text{A}$	$V_{\text{BAT}} - 0.1$		V_{BAT}	
V_{IH}	High-level input		1.5	2.0	2.5	V
$I_{\text{AFE FUSE(PU)}}$	Internal pullup current	$V_{\text{BAT}} \geq 8\text{ V}$, $V_{\text{AFE FUSE}} = \text{VSS}$		150	330	nA
$R_{\text{AFE FUSE}}$	Output impedance		2	2.6	3.2	k Ω
C_{IN}	Input capacitance			5		pF
t_{DELAY}	Fuse trip detection delay		128		256	μs
t_{RISE}	Fuse output rise time	$V_{\text{BAT}} \geq 8\text{ V}$, $C_L = 1\text{ nF}$, $V_{\text{OH}} = 0\text{ V}$ to 5 V		5	20	μs

7.21 Internal Temperature Sensor

Typical values stated where $T_A = 25^\circ\text{C}$ and $V_{CC} = 14.4\text{ V}$, Min/Max values stated where $T_A = -40^\circ\text{C}$ to 85°C and $V_{CC} = 2.2\text{ V}$ to 26 V (unless otherwise noted)

PARAMETER		TEST CONDITIONS	MIN	TYP	MAX	UNIT
V_{TEMP}	Internal temperature sensor voltage drift	$V_{\text{TEMP P}}$	-1.9	-2.0	-2.1	mV/ $^\circ\text{C}$
		$V_{\text{TEMP P}} - V_{\text{TEMP N}}$, assured by design	0.177	0.178	0.179	

7.22 TS1, TS2, TS3, TS4

Typical values stated where $T_A = 25^\circ\text{C}$ and $V_{CC} = 14.4\text{ V}$, Min/Max values stated where $T_A = -40^\circ\text{C}$ to 85°C and $V_{CC} = 2.2\text{ V}$ to 26 V (unless otherwise noted)

PARAMETER		TEST CONDITIONS	MIN	TYP	MAX	UNIT
V_{IN}	Input voltage range	TS1, TS2, TS3, TS4, $V_{\text{BIAS}} = V_{\text{REF1}}$	-0.2	$0.8 \times V_{\text{REF1}}$		V
		TS1, TS2, TS3, TS4, $V_{\text{BIAS}} = V_{\text{REG}}$	-0.2	$0.8 \times V_{\text{REG}}$		
$R_{\text{NTC(PU)}}$	Internal pullup resistance	TS1, TS2, TS3, TS4	14.4	18	21.6	k Ω
$R_{\text{NTC(DRIFT)}}$	Resistance drift over temperature	TS1, TS2, TS3, TS4	-360	-280	-200	PPM/ $^\circ\text{C}$

7.23 PTC, PTCEN

Typical values stated where $T_A = 25^\circ\text{C}$ and $V_{CC} = 14.4\text{ V}$, Min/Max values stated where $T_A = -40^\circ\text{C}$ to 85°C and $V_{CC} = 2.2\text{ V}$ to 26 V (unless otherwise noted)

PARAMETER	TEST CONDITIONS	MIN	TYP	MAX	UNIT
$R_{\text{PTC(TRIP)}}$ PTC trip resistance		1.2	2.5	3.95	$\text{M}\Omega$
$V_{\text{PTC(TRIP)}}$ PTC trip voltage	$V_{\text{PTC(TRIP)}} = V_{\text{PTCEN}} - V_{\text{PTC}}$	200	500	890	mV
I_{PTC} Internal PTC current bias	$T_A = -40^\circ\text{C}$ to 110°C	200	290	350	nA
$t_{\text{PTC(DELAY)}}$ PTC delay time	$T_A = -40^\circ\text{C}$ to 110°C	40	80	145	ms

7.24 Internal 1.8-V LDO

Typical values stated where $T_A = 25^\circ\text{C}$ and $V_{CC} = 14.4\text{ V}$, Min/Max values stated where $T_A = -40^\circ\text{C}$ to 85°C and $V_{CC} = 2.2\text{ V}$ to 26 V (unless otherwise noted)

PARAMETER	TEST CONDITIONS	MIN	TYP	MAX	UNIT
V_{REG} Regulator voltage		1.6	1.8	2.0	V
$\Delta V_{\text{O(TEMP)}}$ Regulator output over temperature	$\Delta V_{\text{REG}}/\Delta T_A$, $I_{\text{REG}} = 10\text{ mA}$		$\pm 0.25\%$		
$\Delta V_{\text{O(LINE)}}$ Line regulation	$\Delta V_{\text{REG}}/\Delta V_{\text{BAT}}$, $V_{\text{BAT}} = 10\text{ mA}$	-0.6%		0.5%	
$\Delta V_{\text{O(LOAD)}}$ Load regulation	$\Delta V_{\text{REG}}/\Delta I_{\text{REG}}$, $I_{\text{REG}} = 0\text{ mA}$ to 10 mA	-1.5%		1.5%	
I_{REG} Regulator output current limit	$V_{\text{REG}} = 0.9 \times V_{\text{REG(NOM)}}$, $V_{\text{IN}} > 2.2\text{ V}$	20			mA
I_{SC} Regulator short-circuit current limit	$V_{\text{REG}} = 0 \times V_{\text{REG(NOM)}}$	25	40	55	mA
PSRR_{REG} Power supply rejection ratio	$\Delta V_{\text{BAT}}/\Delta V_{\text{REG}}$, $I_{\text{REG}} = 10\text{ mA}$, $V_{\text{IN}} > 2.5\text{ V}$, $f = 10\text{ Hz}$		40		dB
V_{SLEW} Slew rate enhancement voltage threshold	V_{REG}	1.58	1.65		V

7.25 High-Frequency Oscillator

Typical values stated where $T_A = 25^\circ\text{C}$ and $V_{CC} = 14.4\text{ V}$, Min/Max values stated where $T_A = -40^\circ\text{C}$ to 85°C and $V_{CC} = 2.2\text{ V}$ to 26 V (unless otherwise noted)

PARAMETER	TEST CONDITIONS	MIN	TYP	MAX	UNIT
f_{HFO} Operating frequency			16.78		MHz
$f_{\text{HFO(ERR)}}$ Frequency error	$T_A = -20^\circ\text{C}$ to 70°C , includes frequency drift	-2.5%	$\pm 0.25\%$	2.5%	
	$T_A = -40^\circ\text{C}$ to 85°C , includes frequency drift	-3.5%	$\pm 0.25\%$	3.5%	
$t_{\text{HFO(SU)}}$ Start-up time	$T_A = -20^\circ\text{C}$ to 85°C , oscillator frequency within $\pm 3\%$ of nominal			4	ms
	oscillator frequency within $\pm 3\%$ of nominal			100	μs

7.26 Low-Frequency Oscillator

Typical values stated where $T_A = 25^\circ\text{C}$ and $V_{CC} = 14.4\text{ V}$, Min/Max values stated where $T_A = -40^\circ\text{C}$ to 85°C and $V_{CC} = 2.2\text{ V}$ to 26 V (unless otherwise noted)

PARAMETER	TEST CONDITIONS	MIN	TYP	MAX	UNIT
f_{LFO} Operating frequency			262.144		kHz
$f_{\text{LFO(ERR)}}$ Frequency error	$T_A = -20^\circ\text{C}$ to 70°C , includes frequency drift	-1.5%	$\pm 0.25\%$	1.5%	
	$T_A = -40^\circ\text{C}$ to 85°C , includes frequency drift	-2.5	± 0.25	2.5	
$f_{\text{LFO(FAIL)}}$ Failure detection frequency		30	80	100	kHz

7.27 Voltage Reference 1

Typical values stated where $T_A = 25^\circ\text{C}$ and $V_{CC} = 14.4\text{ V}$, Min/Max values stated where $T_A = -40^\circ\text{C}$ to 85°C and $V_{CC} = 2.2\text{ V}$ to 26 V (unless otherwise noted)

PARAMETER		TEST CONDITIONS	MIN	TYP	MAX	UNIT
V_{REF1}	Internal reference voltage	$T_A = 25^\circ\text{C}$, after trim	1.21	1.215	1.22	V
$V_{REF1(DRIFT)}$	Internal reference voltage drift	$T_A = 0^\circ\text{C}$ to 60°C , after trim		± 50		PPM/ $^\circ\text{C}$
		$T_A = -40^\circ\text{C}$ to 85°C , after trim		± 80		

7.28 Voltage Reference 2

Typical values stated where $T_A = 25^\circ\text{C}$ and $V_{CC} = 14.4\text{ V}$, Min/Max values stated where $T_A = -40^\circ\text{C}$ to 85°C and $V_{CC} = 2.2\text{ V}$ to 26 V (unless otherwise noted)

PARAMETER		TEST CONDITIONS	MIN	TYP	MAX	UNIT
V_{REF2}	Internal reference voltage	$T_A = 25^\circ\text{C}$, after trim	1.22	1.225	1.23	V
$V_{REF2(DRIFT)}$	Internal reference voltage drift	$T_A = 0^\circ\text{C}$ to 60°C , after trim		± 50		PPM/ $^\circ\text{C}$
		$T_A = -40^\circ\text{C}$ to 85°C , after trim		± 80		

7.29 Instruction Flash

Typical values stated where $T_A = 25^\circ\text{C}$ and $V_{CC} = 14.4\text{ V}$, Min/Max values stated where $T_A = -40^\circ\text{C}$ to 85°C and $V_{CC} = 2.2\text{ V}$ to 26 V (unless otherwise noted)

PARAMETER		TEST CONDITIONS	MIN	TYP	MAX	UNIT
	Data retention		10			Years
	Flash programming write cycles		1000			Cycles
$t_{PROGWORD}$	Word programming time	$T_A = -40^\circ\text{C}$ to 85°C			40	μs
$t_{MASSERASE}$	Mass-erase time	$T_A = -40^\circ\text{C}$ to 85°C			40	ms
$t_{PAGEERASE}$	Page-erase time	$T_A = -40^\circ\text{C}$ to 85°C			40	ms
$I_{FLASHREAD}$	Flash-read current	$T_A = -40^\circ\text{C}$ to 85°C			2	mA
$I_{FLASHWRITE}$	Flash-write current	$T_A = -40^\circ\text{C}$ to 85°C			5	mA
$I_{FLASHERASE}$	Flash-erase current	$T_A = -40^\circ\text{C}$ to 85°C			15	mA

7.30 Data Flash

Typical values stated where $T_A = 25^\circ\text{C}$ and $V_{CC} = 14.4\text{ V}$, Min/Max values stated where $T_A = -40^\circ\text{C}$ to 85°C and $V_{CC} = 2.2\text{ V}$ to 26 V (unless otherwise noted)

PARAMETER		TEST CONDITIONS	MIN	TYP	MAX	UNIT
	Data retention		10			Years
	Flash programming write cycles		20000			Cycles
$t_{PROGWORD}$	Word programming time	$T_A = -40^\circ\text{C}$ to 85°C			40	μs
$t_{MASSERASE}$	Mass-erase time	$T_A = -40^\circ\text{C}$ to 85°C			40	ms
$t_{PAGEERASE}$	Page-erase time	$T_A = -40^\circ\text{C}$ to 85°C			40	ms
$I_{FLASHREAD}$	Flash-read current	$T_A = -40^\circ\text{C}$ to 85°C			1	mA
$I_{FLASHWRITE}$	Flash-write current	$T_A = -40^\circ\text{C}$ to 85°C			5	mA
$I_{FLASHERASE}$	Flash-erase current	$T_A = -40^\circ\text{C}$ to 85°C			15	mA

7.31 OCD, SCC, SCD1, SCD2 Current Protection Thresholds

Typical values stated where $T_A = 25^\circ\text{C}$ and $V_{CC} = 14.4\text{ V}$, Min/Max values stated where $T_A = -40^\circ\text{C}$ to 85°C and $V_{CC} = 2.2\text{ V}$ to 26 V (unless otherwise noted)

PARAMETER		TEST CONDITIONS	MIN	TYP	MAX	UNIT
V_{OCD}	OCD detection threshold voltage range	$V_{\text{OCD}} = V_{\text{SRP}} - V_{\text{SRN}}$, AFE PROTECTION CONTROL[RSNS] = 1	-16.6		-100	mV
		$V_{\text{OCD}} = V_{\text{SRP}} - V_{\text{SRN}}$, AFE PROTECTION CONTROL[RSNS] = 0	-8.3		-50	
ΔV_{OCD}	OCD detection threshold voltage program step	$V_{\text{OCD}} = V_{\text{SRP}} - V_{\text{SRN}}$, AFE PROTECTION CONTROL[RSNS] = 1		-5.56		mV
		$V_{\text{OCD}} = V_{\text{SRP}} - V_{\text{SRN}}$, AFE PROTECTION CONTROL[RSNS] = 0		-2.78		
V_{SCC}	SCC detection threshold voltage range	$V_{\text{SCC}} = V_{\text{SRP}} - V_{\text{SRN}}$, AFE PROTECTION CONTROL[RSNS] = 1	44.4		200	mV
		$V_{\text{SCC}} = V_{\text{SRP}} - V_{\text{SRN}}$, AFE PROTECTION CONTROL[RSNS] = 0	22.2		100	
ΔV_{SCC}	SCC detection threshold voltage program step	$V_{\text{SCC}} = V_{\text{SRP}} - V_{\text{SRN}}$, AFE PROTECTION CONTROL[RSNS] = 1		22.2		mV
		$V_{\text{SCC}} = V_{\text{SRP}} - V_{\text{SRN}}$, AFE PROTECTION CONTROL[RSNS] = 0		11.1		
V_{SCD1}	SCD1 detection threshold voltage range	$V_{\text{SCD1}} = V_{\text{SRP}} - V_{\text{SRN}}$, AFE PROTECTION CONTROL[RSNS] = 1	-44.4		-200	mV
		$V_{\text{SCD1}} = V_{\text{SRP}} - V_{\text{SRN}}$, AFE PROTECTION CONTROL[RSNS] = 0	-22.2		-100	
ΔV_{SCD1}	SCD1 detection threshold voltage program step	$V_{\text{SCD1}} = V_{\text{SRP}} - V_{\text{SRN}}$, AFE PROTECTION CONTROL[RSNS] = 1		-22.2		mV
		$V_{\text{SCD1}} = V_{\text{SRP}} - V_{\text{SRN}}$, AFE PROTECTION CONTROL[RSNS] = 0		-11.1		
V_{SCD2}	SCD2 detection threshold voltage range	$V_{\text{SCD2}} = V_{\text{SRP}} - V_{\text{SRN}}$, AFE PROTECTION CONTROL[RSNS] = 1	-44.4		-200	mV
		$V_{\text{SCD2}} = V_{\text{SRP}} - V_{\text{SRN}}$, AFE PROTECTION CONTROL[RSNS] = 0	-22.2		-100	
ΔV_{SCD2}	SCD2 detection threshold voltage program step	$V_{\text{SCD2}} = V_{\text{SRP}} - V_{\text{SRN}}$, AFE PROTECTION CONTROL[RSNS] = 1		-22.2		mV
		$V_{\text{SCD2}} = V_{\text{SRP}} - V_{\text{SRN}}$, AFE PROTECTION CONTROL[RSNS] = 0		-11.1		
V_{OFFSET}	OCD, SCC, and SCDx offset error	Post-trim	-2.5		2.5	mV
V_{SCALE}	OCD, SCC, and SCDx scale error	No trim	-10%		10%	—
		Post-trim	-5%		5%	

7.32 Timing Requirements: OCD, SCC, SCD1, SCD2 Current Protection Timing

Typical values stated where $T_A = 25^\circ\text{C}$ and $V_{CC} = 14.4\text{ V}$, Min/Max values stated where $T_A = -40^\circ\text{C}$ to 85°C and $V_{CC} = 2.2\text{ V}$ to 26 V (unless otherwise noted)

		MIN	NOM	MAX	UNIT
t_{OCD}	OCD detection delay time	1		31	ms
Δt_{OCD}	OCD detection delay time program step		2		ms
t_{SCC}	SCC detection delay time	0		915	μs
Δt_{SCC}	SCC detection delay time program step		61		μs
t_{SCD1}	SCD1 detection delay time	AFE PROTECTION CONTROL[SCDDx2] = 0	0	915	μs
		AFE PROTECTION CONTROL[SCDDx2] = 1	0	1850	

Timing Requirements: OCD, SCC, SCD1, SCD2 Current Protection Timing (continued)

Typical values stated where $T_A = 25^\circ\text{C}$ and $V_{CC} = 14.4\text{ V}$, Min/Max values stated where $T_A = -40^\circ\text{C}$ to 85°C and $V_{CC} = 2.2\text{ V}$ to 26 V (unless otherwise noted)

			MIN	NOM	MAX	UNIT
Δt_{SCD1}	SCD1 detection delay time program step	AFE PROTECTION CONTROL[SCDDx2] = 0	61			μs
		AFE PROTECTION CONTROL[SCDDx2] = 1	121			
t_{SCD2}	SCD2 detection delay time	AFE PROTECTION CONTROL[SCDDx2] = 0	0		458	μs
		AFE PROTECTION CONTROL[SCDDx2] = 1	0		915	
Δt_{SCD2}	SCD2 detection delay time program step	AFE PROTECTION CONTROL[SCDDx2] = 0	30.5			μs
		AFE PROTECTION CONTROL[SCDDx2] = 1	61			
t_{DETECT}	Current fault detect time	$V_{\text{SRP}} - V_{\text{SRN}} = V_T - 3\text{ mV}$ for OCD, SCD1, and SC2, $V_{\text{SRP}} - V_{\text{SRN}} = V_T + 3\text{ mV}$ for SCC			160	μs
t_{ACC}	Current fault delay time accuracy	Max delay setting	-10%		10%	

7.33 Timing Requirements: SMBus

Typical values stated where $T_A = 25^\circ\text{C}$ and $V_{CC} = 14.4\text{ V}$, Min/Max values stated where $T_A = -40^\circ\text{C}$ to 85°C and $V_{CC} = 2.2\text{ V}$ to 26 V (unless otherwise noted)

			MIN	NOM	MAX	UNIT
f_{SMB}	SMBus operating frequency	SLAVE mode, SMBC 50% duty cycle	10		100	kHz
f_{MAS}	SMBus master clock frequency	MASTER mode, no clock low slave extend	51.2			kHz
t_{BUF}	Bus free time between start and stop		4.7			μs
$t_{\text{HD(START)}}$	Hold time after (repeated) start		4.0			μs
$t_{\text{SU(START)}}$	Repeated start setup time		4.7			μs
$t_{\text{SU(STOP)}}$	Stop setup time		4.0			μs
$t_{\text{HD(DATA)}}$	Data hold time		300			ns
$t_{\text{SU(DATA)}}$	Data setup time		250			ns
t_{TIMEOUT}	Error signal detect time		25		35	ms
t_{LOW}	Clock low period		4.7			μs
t_{HIGH}	Clock high period		4.0		50	μs
t_{R}	Clock rise time	10% to 90%			1000	ns
t_{F}	Clock fall time	90% to 10%			300	ns
$t_{\text{LOW(SEXT)}}$	Cumulative clock low slave extend time				25	ms
$t_{\text{LOW(MEXT)}}$	Cumulative clock low master extend time				10	ms

7.34 Timing Requirements: SMBus XL

Typical values stated where $T_A = 25^\circ\text{C}$ and $V_{CC} = 14.4\text{ V}$, Min/Max values stated where $T_A = -40^\circ\text{C}$ to 85°C and $V_{CC} = 2.2\text{ V}$ to 26 V (unless otherwise noted)

			MIN	NOM	MAX	UNIT
f_{SMBXL}	SMBus XL operating frequency	SLAVE mode	40		400	kHz
t_{BUF}	Bus free time between start and stop		4.7			μs
$t_{\text{HD(START)}}$	Hold time after (repeated) start		4.0			μs

Timing Requirements: SMBus XL (continued)

Typical values stated where $T_A = 25^\circ\text{C}$ and $V_{CC} = 14.4\text{ V}$, Min/Max values stated where $T_A = -40^\circ\text{C}$ to 85°C and $V_{CC} = 2.2\text{ V}$ to 26 V (unless otherwise noted)

		MIN	NOM	MAX	UNIT
$t_{\text{SU(START)}}$	Repeated start setup time	4.7			μs
$t_{\text{SU(STOP)}}$	Stop setup time	4.0			μs
t_{TIMEOUT}	Error signal detect time	5		20	ms
t_{LOW}	Clock low period			20	μs
t_{HIGH}	Clock high period			20	μs

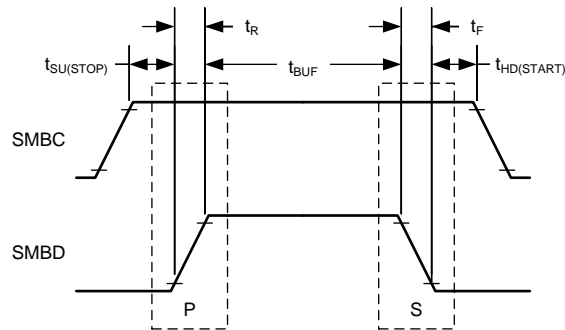
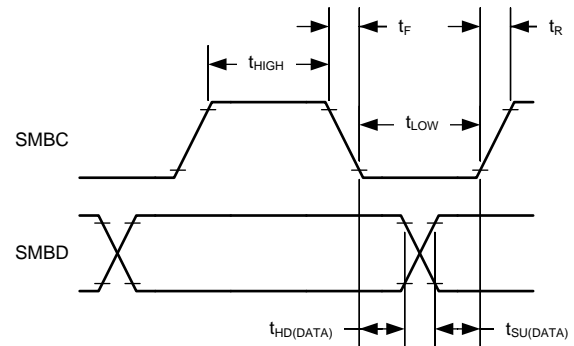
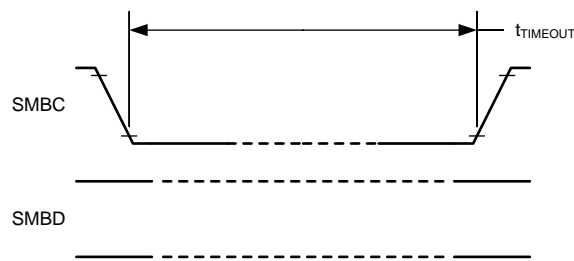
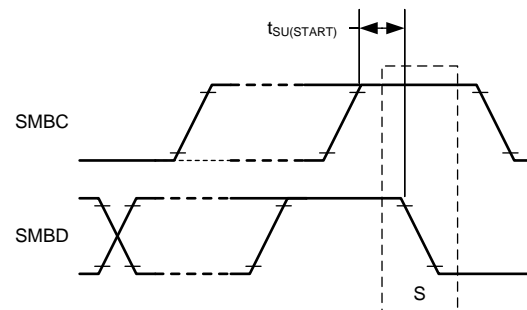

Start and Stop Condition

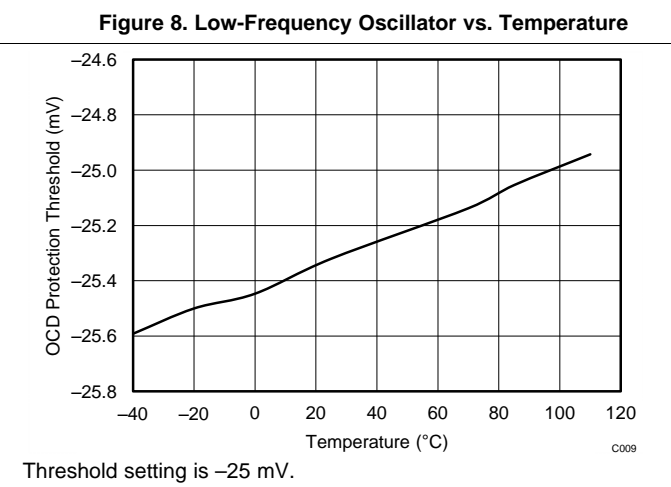
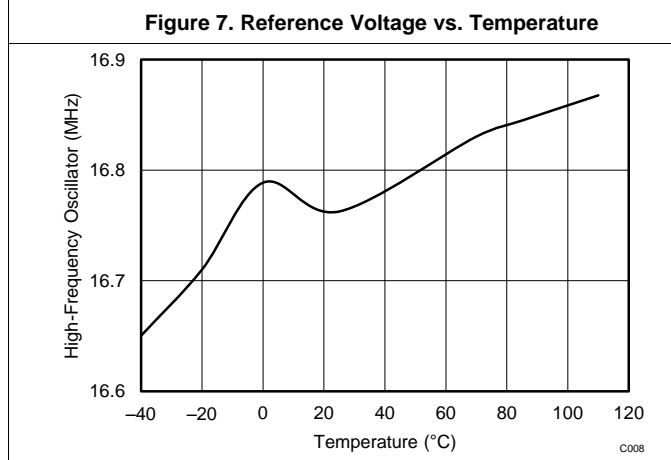
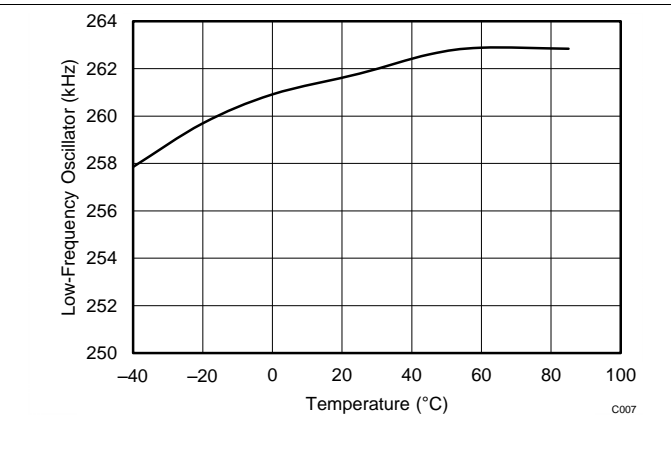
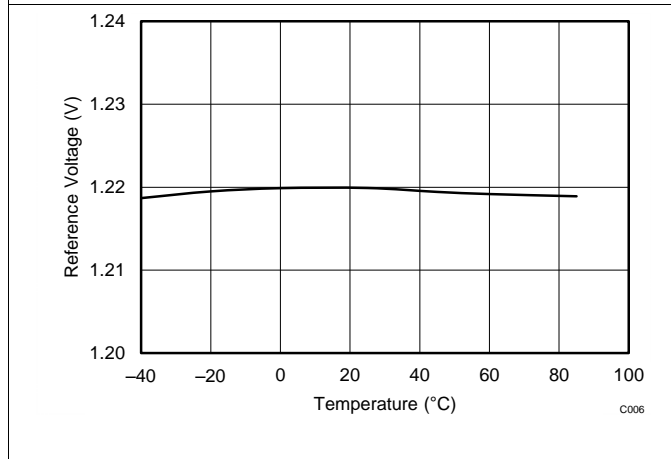
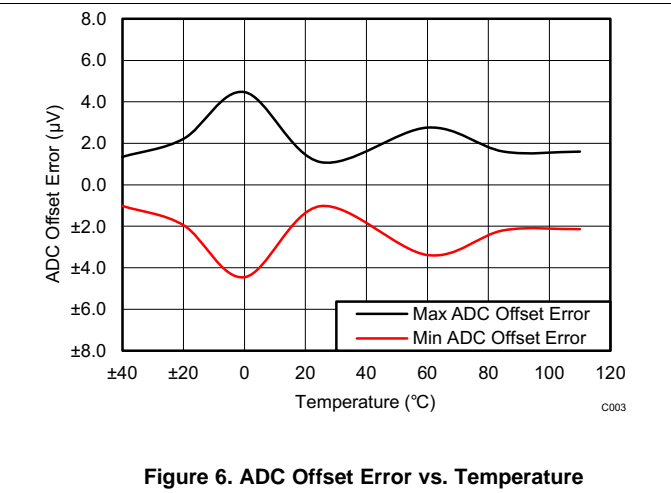
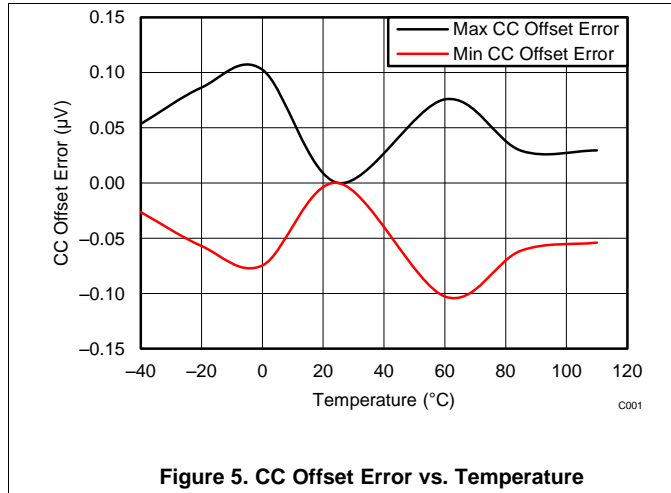
Wait and Hold Condition

Timeout Condition

Repeated Start Condition
Figure 4. SMBus Timing Diagram

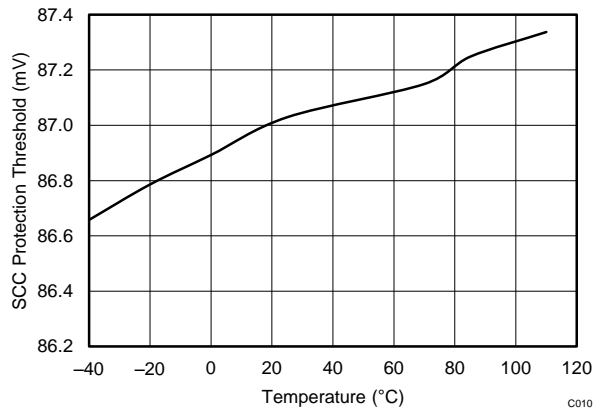
7.35 Typical Characteristics



Threshold setting is -25 mV.

Typical Characteristics (continued)



Threshold setting is 88.85 mV.

Figure 11. Short Circuit Charge Protection Threshold vs. Temperature

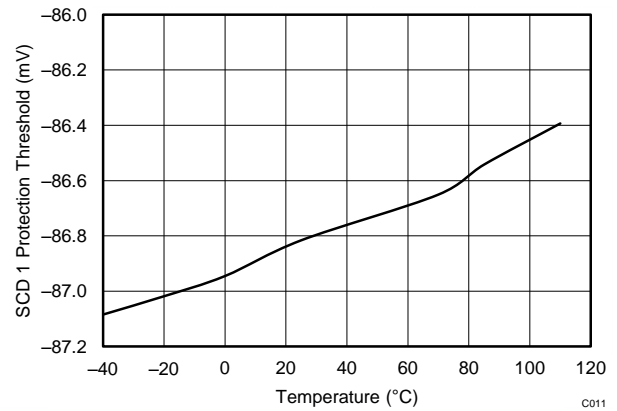

Threshold setting is -88.85 mV.

Figure 12. Short Circuit Discharge 1 Protection Threshold vs. Temperature

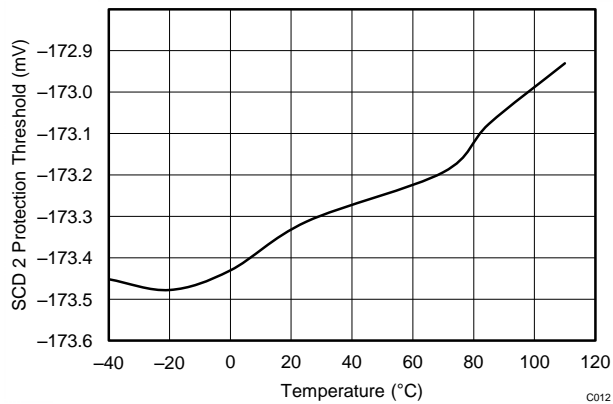

Threshold setting is -177.7 mV.

Figure 13. Short Circuit Discharge 2 Protection Threshold vs. Temperature

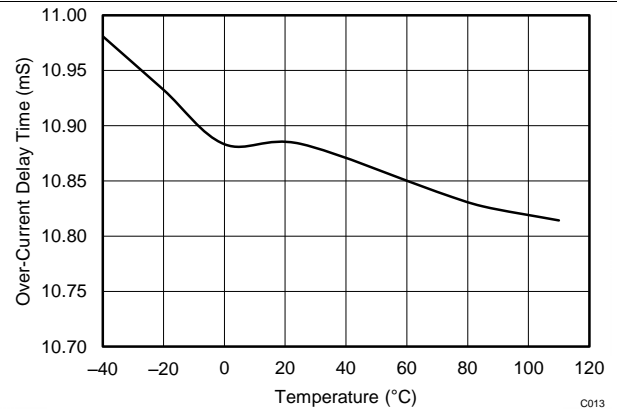

Threshold setting is 11 ms.

Figure 14. Overcurrent Delay Time vs. Temperature

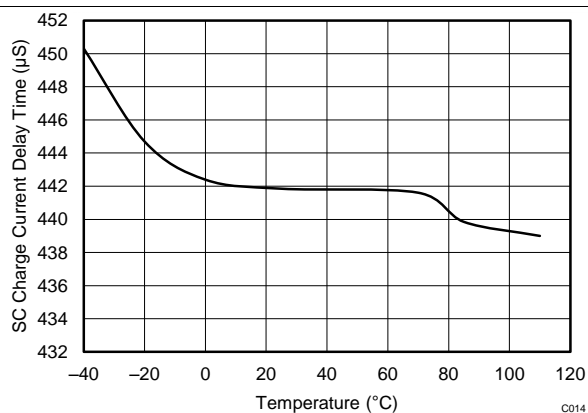

Threshold setting is 465 µs.

Figure 15. Short Circuit Charge Current Delay Time vs. Temperature

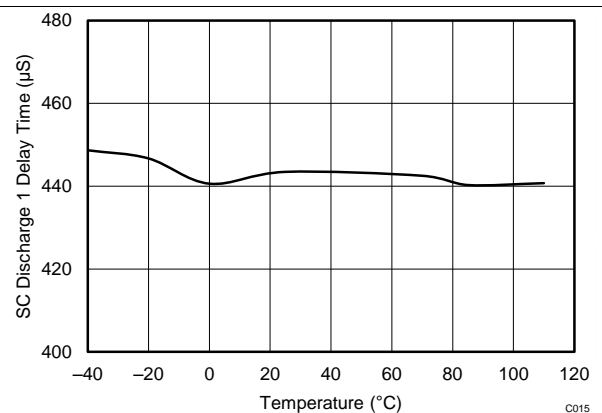

Threshold setting is 465 µs (including internal delay).

Figure 16. Short Circuit Discharge 1 Delay Time vs. Temperature

Typical Characteristics (continued)

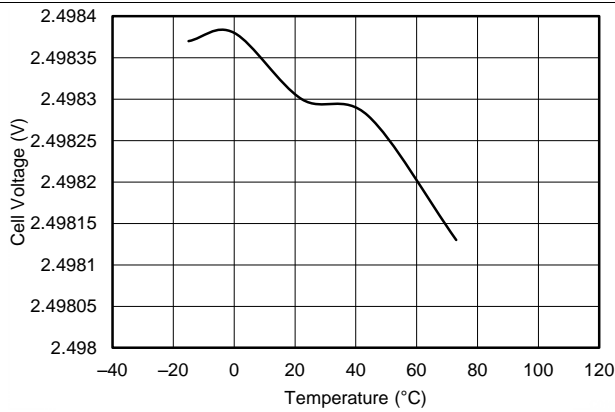
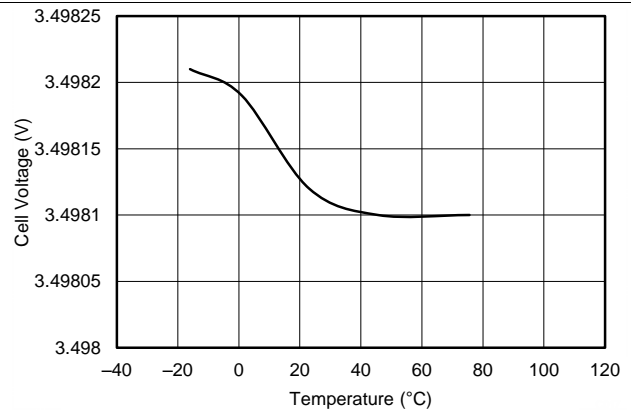
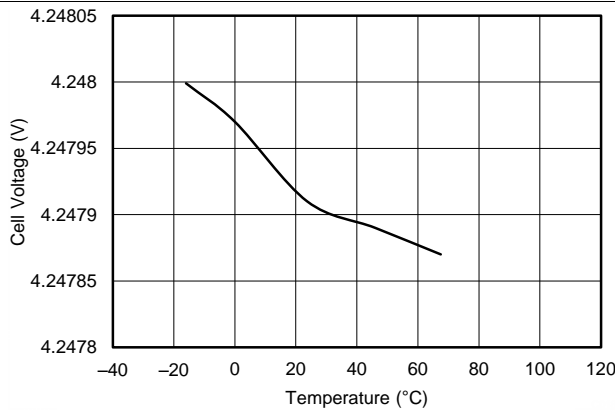

Figure 17. V_{CELL} Measurement at 2.5-V vs. Temperature



This is the V_{CELL} average for single cell.

Figure 18. V_{CELL} Measurement at 3.5-V vs. Temperature



This is the V_{CELL} average for single cell.

Figure 19. V_{CELL} Measurement at 4.25-V vs. Temperature

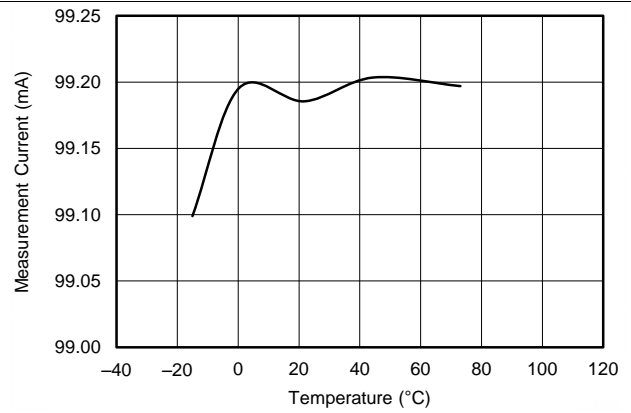

$I_{SET} = 100 \text{ mA}$

Figure 20. I measured vs. Temperature

8 Detailed Description

8.1 Overview

The bq40z50-R2 device, incorporating patented Impedance Track™ technology, provides cell balancing while charging or at rest. This fully integrated, single-chip, pack-based solution provides a rich array of features for gas gauging, protection, and authentication for 1-series, 2-series, 3-series, and 4-series cell Li-Ion and Li-Polymer battery packs, including a diagnostic lifetime data monitor and black box recorder.

8.2 Functional Block Diagram

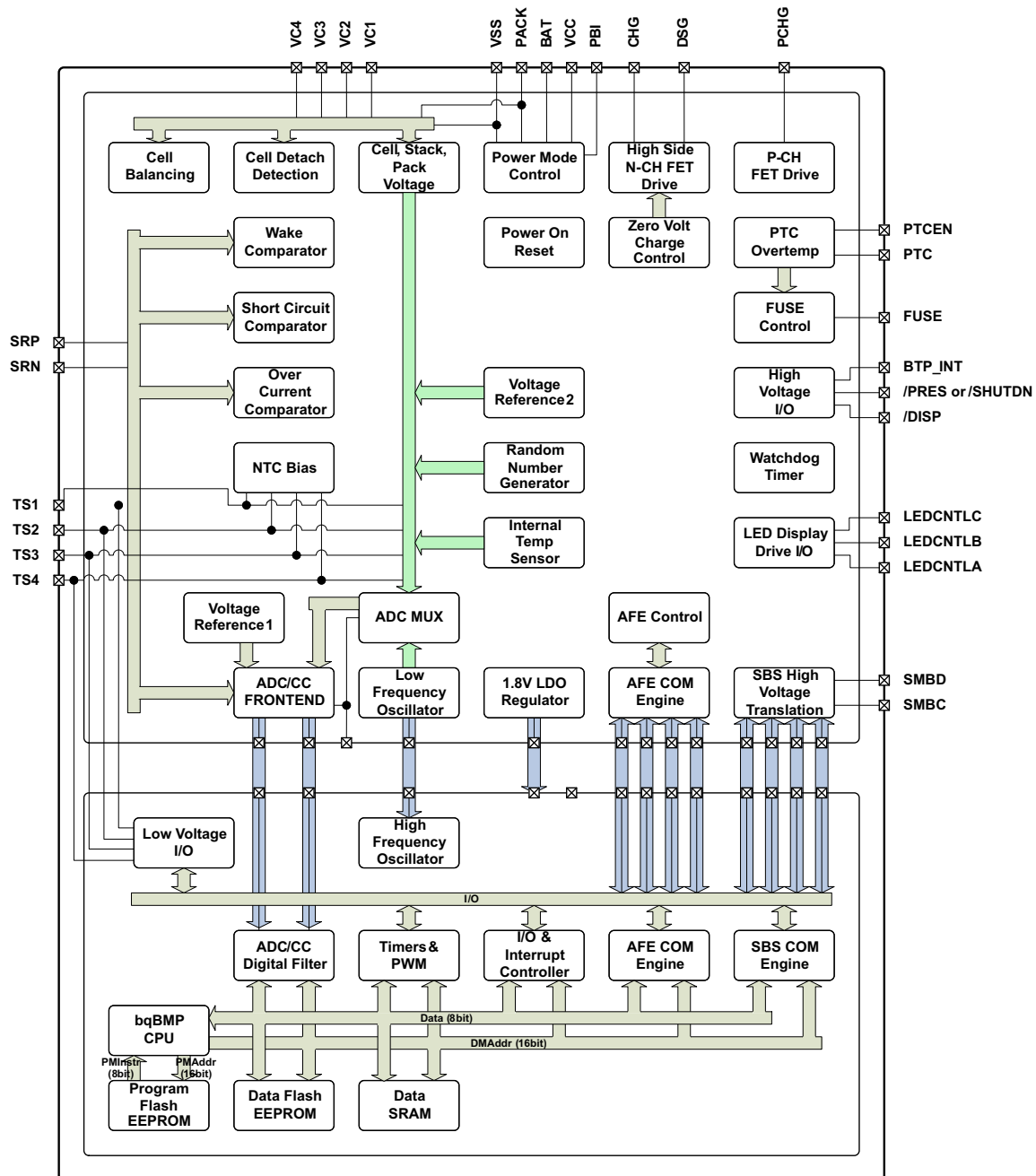

Copyright © 2017, Texas Instruments Incorporated

8.3 Feature Description

8.3.1 Primary (1st Level) Safety Features

The bq40z50-R2 supports a wide range of battery and system protection features that can easily be configured. See the *bq40z50-R2 Technical Reference Manual* ([SLUUBK0](#)) for detailed descriptions of each protection function.

The primary safety features include:

- Cell Overvoltage Protection
- Cell Undervoltage Protection
- Cell Undervoltage Protection Compensated
- Overcurrent in Charge Protection
- Overcurrent in Discharge Protection
- Overload in Discharge Protection
- Short Circuit in Charge Protection
- Short Circuit in Discharge Protection
- Overtemperature in Charge Protection
- Overtemperature in Discharge Protection
- Undertemperature in Charge Protection
- Undertemperature in Discharge Protection
- Overtemperature FET protection
- Precharge Timeout Protection
- Host Watchdog Timeout Protection
- Fast Charge Timeout Protection
- Overcharge Protection
- Overcharging Voltage Protection
- Overcharging Current Protection
- Over Precharge Current Protection

8.3.2 Secondary (2nd Level) Safety Features

The secondary safety features of the bq40z50-R2 can be used to indicate more serious faults via the FUSE pin. This pin can be used to blow an in-line fuse to permanently disable the battery pack from charging or discharging. See the *bq40z50-R2 Technical Reference Manual* ([SLUUBK0](#)) for detailed descriptions of each protection function.

The secondary safety features provide protection against:

- Safety Overvoltage Permanent Failure
- Safety Undervoltage Permanent Failure
- Safety Overtemperature Permanent Failure
- Safety FET Overtemperature Permanent Failure
- Qmax Imbalance Permanent Failure
- Impedance Imbalance Permanent Failure
- Capacity Degradation Permanent Failure
- Cell Balancing Permanent Failure
- Fuse Failure Permanent Failure
- PTC Permanent Failure
- Voltage Imbalance At Rest Permanent Failure
- Voltage Imbalance Active Permanent Failure
- Charge FET Permanent Failure
- Discharge FET Permanent Failure
- AFE Register Permanent Failure
- AFE Communication Permanent Failure

Feature Description (continued)

- Second Level Protector Permanent Failure
- Instruction Flash Checksum Permanent Failure
- Open Cell Connection Permanent Failure
- Data Flash Permanent Failure
- Open Thermistor Permanent Failure

8.3.3 Charge Control Features

The bq40z50-R2 charge control features include:

- Supports JEITA temperature ranges. Reports charging voltage and charging current according to the active temperature range
- Handles more complex charging profiles. Allows for splitting the standard temperature range into two sub-ranges and allows for varying the charging current according to the cell voltage
- Reports the appropriate charging current needed for constant current charging and the appropriate charging voltage needed for constant voltage charging to a smart charger using SMBus broadcasts
- Reduces the charge difference of the battery cells in a fully charged state of the battery pack gradually using a voltage-based cell balancing algorithm during charging. A voltage threshold can be set up for cell balancing to be active. This prevents fully charged cells from overcharging and causing excessive degradation and also increases the usable pack energy by preventing premature charge termination.
- Supports pre-charging/zero-volt charging
- Supports charge inhibit and charge suspend if battery pack temperature is out of temperature range
- Reports charging fault and also indicates charge status via charge and discharge alarms

8.3.4 Gas Gauging

The bq40z50-R2 uses the Impedance Track algorithm to measure and calculate the available capacity in battery cells. The bq40z50-R2 accumulates a measure of charge and discharge currents and compensates the charge current measurement for the temperature and state-of-charge of the battery. The bq40z50-R2 estimates self-discharge of the battery and also adjusts the self-discharge estimation based on temperature. The device also has TURBO Mode 2.0 support, which enables the bq40z50-R2 to provide the necessary data for the MCU to determine what level of peak power consumption can be applied without causing a system reset or transient battery voltage level spike to trigger termination flags. See the *bq40z50-R2 Technical Reference Manual (SLUUBK0)* for further details.

8.3.5 Configuration

8.3.5.1 Oscillator Function

The bq40z50-R2 fully integrates the system oscillators and does not require any external components to support this feature.

8.3.5.2 System Present Operation

The bq40z50-R2 checks the $\overline{\text{PRES}}$ pin periodically (1 s). If $\overline{\text{PRES}}$ input is pulled to ground by the external system, the bq40z50-R2 detects this as system present.

8.3.5.3 Emergency Shutdown

For battery maintenance, the emergency shutdown feature enables a push button action connecting the SHUTDN pin to shut down an embedded battery pack system before removing the battery. A high-to-low transition of the SHUTDN pin signals the bq40z50-R2 to turn off the CHG and DSG FETs, disconnecting the power from the system to safely remove the battery pack. The CHG and DSG FETs can be turned on again by another high-to-low transition detected by the SHUTDN pin or when a data flash configurable timeout is reached.

8.3.5.4 1-Series, 2-Series, 3-Series, or 4-Series Cell Configuration

In a 1-series cell configuration, VC4 is shorted to VC, VC2, and VC1. In a 2-series cell configuration, VC4 is shorted to VC3 and VC2. In a 3-series cell configuration, VC4 is shorted to VC3.

Feature Description (continued)

8.3.5.5 Cell Balancing

The device supports cell balancing by bypassing the current of each cell during charging or at rest. If the device's internal bypass is used, up to 10 mA can be bypassed and multiple cells can be bypassed at the same time. Higher cell balance current can be achieved by using an external cell balancing circuit. In external cell balancing mode, only one cell at a time can be balanced.

The cell balancing algorithm determines the amount of charge needed to be bypassed to balance the capacity of all cells.

8.3.6 Battery Parameter Measurements

8.3.6.1 Charge and Discharge Counting

The bq40z50-R2 uses an integrating delta-sigma analog-to-digital converter (ADC) for current measurement, and a second delta-sigma ADC for individual cell and battery voltage and temperature measurement.

The integrating delta-sigma ADC measures the charge/discharge flow of the battery by measuring the voltage drop across a small-value sense resistor between the SRP and SRN terminals. The integrating ADC measures bipolar signals from -0.1 V to 0.1 V . The bq40z50-R2 detects charge activity when $V_{SR} = V_{(SRP)} - V_{(SRN)}$ is positive, and discharge activity when $V_{SR} = V_{(SRP)} - V_{(SRN)}$ is negative. The bq40z50-R2 continuously integrates the signal over time, using an internal counter. The fundamental rate of the counter is 0.26 nVh.

8.3.7 Battery Trip Point (BTP)

Required for WIN8 OS, the battery trip point (BTP) feature indicates when the RSOC of a battery pack has depleted to a certain value set in a DF register. This feature enables a host to program two capacity-based thresholds that govern the triggering of a BTP interrupt on the BTP_INT pin, and the setting or clearing of the *OperationStatus[BTP_INT]* on the basis of *RemainingCapacity()*.

An internal weak pullup is applied when the BTP feature is active. Depending on the system design, an external pullup may be required to put on the BTP_INT pin. See [PRES](#), [BTP_INT](#), [DISP](#) for details.

8.3.8 Lifetime Data Logging Features

The bq40z50-R2 offers lifetime data logging for several critical battery parameters. The following parameters are updated every 10 hours if a difference is detected between values in RAM and data flash:

- Maximum and Minimum Cell Voltages
- Maximum Delta Cell Voltage
- Maximum Charge Current
- Maximum Discharge Current
- Maximum Average Discharge Current
- Maximum Average Discharge Power
- Maximum and Minimum Cell Temperature
- Maximum Delta Cell Temperature
- Maximum and Minimum Internal Sensor Temperature
- Maximum FET Temperature
- Number of Safety Events Occurrences and the Last Cycle of the Occurrence
- Number of Valid Charge Termination and the Last Cycle of the Valid Charge Termination
- Number of Qmax and Ra Updates and the Last Cycle of the Qmax and Ra Updates
- Number of Shutdown Events
- Cell Balancing Time for Each Cell
(This data is updated every 2 hours if a difference is detected.)
- Total FW Runtime and Time Spent in Each Temperature Range
(This data is updated every 2 hours if a difference is detected.)

Feature Description (continued)

8.3.9 Authentication

The bq40z50-R2 supports authentication by the host using SHA-1.

8.3.10 LED Display

The bq40z50-R2 can drive a 3-, 4-, or 5- segment LED display for remaining capacity indication and/or a permanent fail (PF) error code indication.

8.3.11 IATA Support

The bq40z50-R2 supports IATA with several new commands and procedures. See the *bq40z50-R2 Technical Reference Manual (SLUUBK0)* for further details.

8.3.12 Voltage

The bq40z50-R2 updates the individual series cell voltages at 0.25-s intervals. The internal ADC of the bq40z50-R2 measures the voltage, and scales and calibrates it appropriately. This data is also used to calculate the impedance of the cell for the Impedance Track gas gauging.

8.3.13 Current

The bq40z50-R2 uses the SRP and SRN inputs to measure and calculate the battery charge and discharge current using a 1-m Ω to 3-m Ω typ. sense resistor.

8.3.14 Temperature

The bq40z50-R2 has an internal temperature sensor and inputs for four external temperature sensors. All five temperature sensor options can be individually enabled and configured for cell or FET temperature usage. Two configurable thermistor models are provided to allow the monitoring of cell temperature in addition to FET temperature, which use a different thermistor profile.

8.3.15 Communications

The bq40z50-R2 uses SMBus v1.1 with MASTER mode and packet error checking (PEC) options per the SBS specification.

8.3.15.1 SMBus On and Off State

The bq40z50-R2 detects an SMBus off state when SMBC and SMBD are low for two or more seconds. Clearing this state requires that either SMBC or SMBD transition high. The communication bus will resume activity within 1 ms.

8.3.15.2 SBS Commands

See the *bq40z50-R2 Technical Reference Manual (SLUUBK0)* for further details.

8.4 Device Functional Modes

The bq40z50-R2 supports three power modes to reduce power consumption:

- In NORMAL mode, the bq40z50-R2 performs measurements, calculations, protection decisions, and data updates in 250-ms intervals. Between these intervals, the bq40z50-R2 is in a reduced power stage.
- In SLEEP mode, the bq40z50-R2 performs measurements, calculations, protection decisions, and data updates in adjustable time intervals. Between these intervals, the bq40z50-R2 is in a reduced power stage. The bq40z50-R2 has a wake function that enables exit from SLEEP mode when current flow or failure is detected.
- In SHUTDOWN mode, the bq40z50-R2 is completely disabled.

9 Applications and Implementation

NOTE

Information in the following applications sections is not part of the TI component specification, and TI does not warrant its accuracy or completeness. TI's customers are responsible for determining suitability of components for their purposes. Customers should validate and test their design implementation to confirm system functionality.

9.1 Application Information

The bq40z50-R2 is a gas gauge with primary protection support, and can be used with 1-series to 4-series Li-Ion/Li Polymer battery packs. To implement and design a comprehensive set of parameters for a specific battery pack, users need the Battery Management Studio ([bqStudio](#)) graphical user-interface tool installed on a PC during development. The firmware installed on the bqStudio tool has default values for this product, which are summarized in the *bq40z50-R2 Technical Reference Manual (SLUUBK0)*. Using the bqStudio tool, these default values can be changed to cater to specific application requirements during development once the system parameters, such as fault trigger thresholds for protection, enable/disable of certain features for operation, configuration of cells, chemistry that best matches the cell used, and more are known. This data is referred to as the "golden image."

9.2 Typical Applications

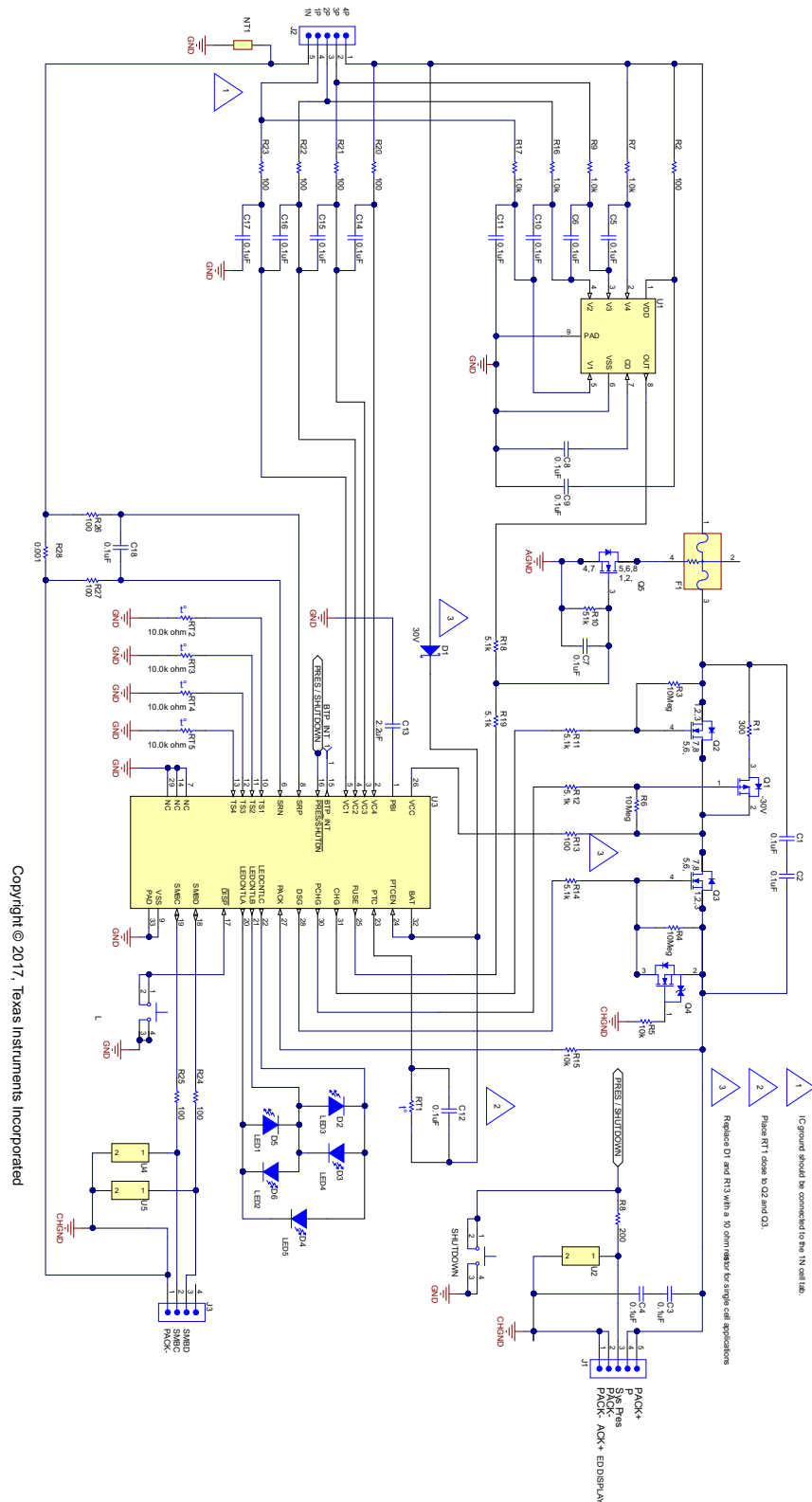

Figure 21. Application Schematic

Typical Applications (continued)

9.2.1 Design Requirements

Table 1 shows the default settings for the main parameters. Use the [bqStudio](#) tool to update the settings to meet the specific application or battery pack configuration requirements.

The device should be calibrated before any gauging test. Follow the procedures on the bqStudio **Calibration** page to calibrate the device, and use the information on the bqStudio **Chemistry** page to update the match chemistry profile to the device.

Table 1. Design Parameters

DESIGN PARAMETER	EXAMPLE
Cell Configuration	3s1p (3-series with 1 Parallel) ⁽¹⁾
Design Capacity	4400 mAh
Device Chemistry	1210 (LiCoO2/graphitized carbon)
Cell Overvoltage at Standard Temperature	4300 mV
Cell Undervoltage	2500 mV
Shutdown Voltage	2300 mV
Overcurrent in CHARGE Mode	6000 mA
Overcurrent in DISCHARGE Mode	–6000 mA
Short Circuit in CHARGE Mode	0.1 V/Rsense across SRP, SRN
Short Circuit in DISCHARGE Mode	0.1 V/Rsense across SRP, SRN
Safety Overvoltage	4500 mV
Cell Balancing	Disabled
Internal and External Temperature Sensor	External Temperature Sensor is used.
Undertemperature Charging	0°C
Undertemperature Discharging	0°C
BROADCAST Mode	Disabled
Battery Trip Point (BTP) with active high interrupt	Disabled

(1) When using the device the first time and if a 1-s or 2-s battery pack is used, then a charger or power supply should be connected to the PACK+ terminal to prevent device shutdown. Then update the cell configuration (see the *bq40z50-R2 Technical Reference Manual* [SLUUBK0] for details) before removing the charger connection.

9.2.2 Detailed Design Procedure

9.2.2.1 High-Current Path

The high-current path begins at the PACK+ terminal of the battery pack. As charge current travels through the pack, it finds its way through protection FETs, a chemical fuse, the Li-Ion cells and cell connections, and the sense resistor, and then returns to the PACK– terminal (see [Figure 22](#)). In addition, some components are placed across the PACK+ and PACK– terminals to reduce effects from electrostatic discharge.

9.2.2.1.1 Protection FETs

Select the N-channel charge and discharge FETs for a given application. Most portable battery applications are a good match for the CSD17308Q3. The TI CSD17308Q3 is a 47A, 30-V device with $R_{ds(on)}$ of 8.2 m Ω when the gate drive voltage is 8 V.

If a precharge FET is used, R1 is calculated to limit the precharge current to the desired rate. Be sure to account for the power dissipation of the series resistor. The precharge current is limited to $(V_{CHARGER} - V_{BAT})/R1$ and maximum power dissipation is $(V_{charger} - V_{bat})^2/R1$.

The gates of all protection FETs are pulled to the source with a high-value resistor between the gate and source to ensure they are turned off if the gate drive is open.

Capacitors C1 and C2 help protect the FETs during an ESD event. Using two devices ensures normal operation if one becomes shorted. To have good ESD protection, the copper trace inductance of the capacitor leads must be designed to be as short and wide as possible. Ensure that the voltage rating of both C1 and C2 are adequate to hold off the applied voltage if one of the capacitors becomes shorted.

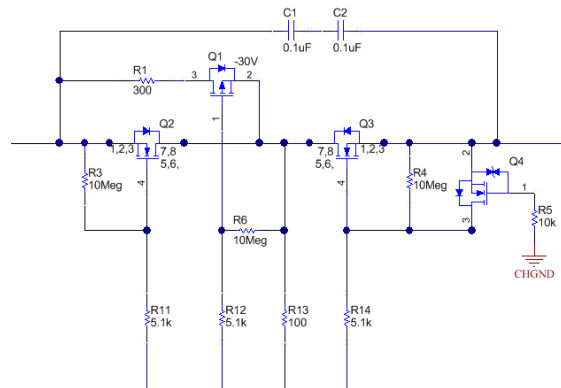

Figure 22. bq40z50-R2 Protection FETs

9.2.2.1.2 Chemical Fuse

The chemical fuse (Dexerials, Uchihashi, and so forth) is ignited under command from either the bq294700 secondary voltage protection IC or from the FUSE pin of the gas gauge. Either of these events applies a positive voltage to the gate of Q5, shown in Figure 23, which then sinks current from the third terminal of the fuse, causing it to ignite and open permanently.

It is important to carefully review the fuse specifications and match the required ignition current to that available from the N-channel FET. Ensure that the proper voltage, current, and $R_{ds(on)}$ ratings are used for this device. The fuse control circuit is discussed in detail in [FUSE Circuitry](#).

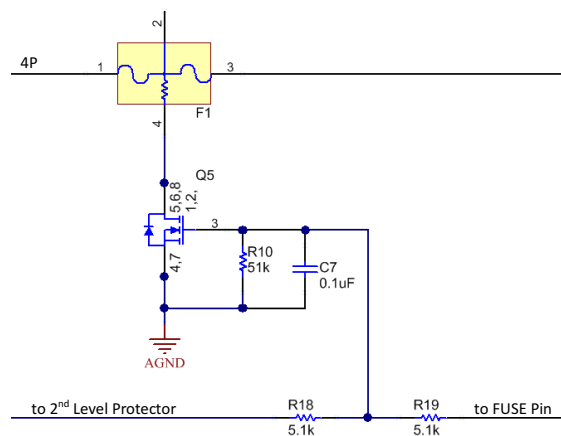

Figure 23. FUSE Circuit

9.2.2.1.3 Li-Ion Cell Connections

For cell connections, it is important to remember that high current flows through the top and bottom connections; therefore, the voltage sense leads at these points must be made with a Kelvin connection to avoid any errors due to a drop in the high-current copper trace. The location marked 4P in Figure 24 indicates the Kelvin connection of the most positive battery node. The connection marked 1N is equally important. The VC5 pin (a ground reference for cell voltage measurement), which is in the older generation devices, is not in the bq40z50-R2 device. Therefore, the single-point connection at 1N to the low-current ground is needed to avoid an unwanted voltage drop through long traces while the gas gauge is measuring the bottom cell voltage.

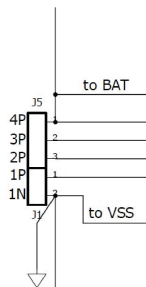

Figure 24. Li-Ion Cell Connections

9.2.2.1.4 Sense Resistor

As with the cell connections, the quality of the Kelvin connections at the sense resistor is critical. The sense resistor must have a temperature coefficient no greater than 50 ppm in order to minimize current measurement drift with temperature. Choose the value of the sense resistor to correspond to the available overcurrent and short-circuit ranges of the bq40z50-R2 device. Select the smallest value possible to minimize the negative voltage generated on the bq40z50-R2 V_{SS} node(s) during a short circuit. This pin has an absolute minimum of -0.3 V. Parallel resistors can be used as long as good Kelvin sensing is ensured. The device is designed to support a 1-m Ω to 3-m Ω sense resistor.

The bq40z50-R2 ground scheme is different from that of the older generation devices. In previous devices, the device ground (or low current ground) is connected to the SRN side of the R_{SENSE} resistor pad. In the bq40z50-R2 device, however, connects the low-current ground on the SRP side of the R_{SENSE} resistor pad, close to the battery 1N terminal (see [Li-Ion Cell Connections](#)). This is because the bq40z50-R2 device has one less VC pin (a ground reference pin VC5) compared to the previous devices. The pin was removed and was internally combined to SRP.

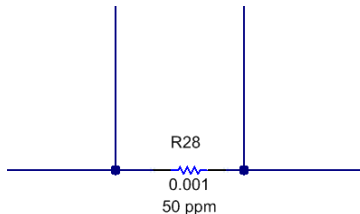

Figure 25. Sense Resistor

9.2.2.1.5 ESD Mitigation

A pair of series 0.1- μ F ceramic capacitors is placed across the PACK+ and PACK– terminals to help in the mitigation of external electrostatic discharges. The two devices in series ensure continued operation of the pack if one of the capacitors becomes shorted.

Optionally, a tranzorb such as the SMBJ2A can be placed across the terminals to further improve ESD immunity.

9.2.2.2 Gas Gauge Circuit

The gas gauge circuit includes the bq40z50-R2 and its peripheral components. These components are divided into the following groups: differential low-pass filter, PBI, system present, SMBus communication, fuse circuit, and LED.

9.2.2.2.1 Coulomb-Counting Interface

The bq40z50-R2 uses an integrating delta-sigma ADC for current measurements. Add a 100- Ω resistor from the sense resistor to the SRP and SRN inputs of the device. Place a 0.1- μ F (C18) filter capacitor across the SRP and SRN inputs.

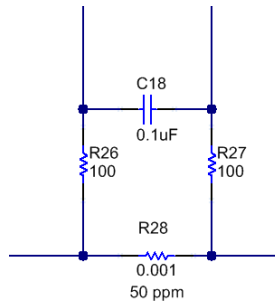
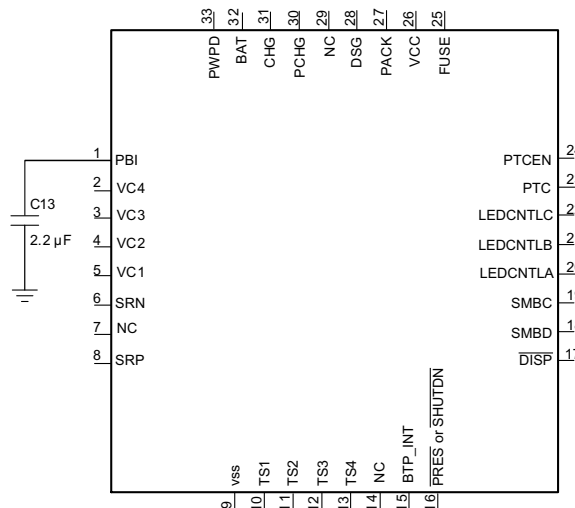

Figure 26. Differential Filter

9.2.2.2.2 Power Supply Decoupling and PBI

The bq40z50-R2 device has an internal LDO that is internally compensated and does not require an external decoupling capacitor.

The PBI pin is used as a power supply backup input pin providing power during brief transient power outages. A standard 2.2- μ F ceramic capacitor is connected from the PBI pin to ground, as shown in Figure 27.



Copyright © 2017, Texas Instruments Incorporated

Figure 27. Power Supply Decoupling

9.2.2.2.3 System Present

The System Present signal informs the gas gauge whether the pack is installed into or removed from the system. In the host system, this pin is grounded. The PRES pin of the bq40z50-R2 device is occasionally sampled to test for system present. To save power, an internal pullup is provided by the gas gauge during a brief 4- μ s sampling pulse once per second. A resistor can be used to pull the signal low and the resistance must be 20 k Ω or lower to ensure that the test pulse is lower than the VIL limit. The pullup current source is typically 10 μ A to 20 μ A.

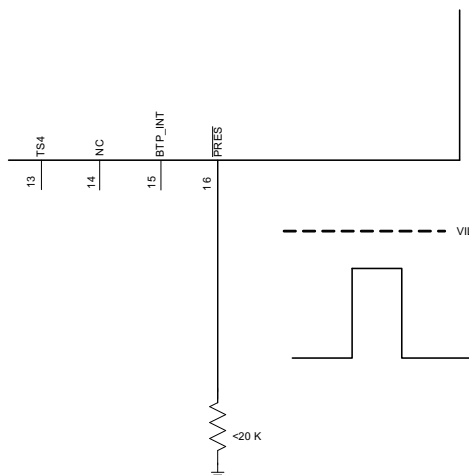

Figure 28. System Present Pull-Down Resistor

Because the System Present signal is part of the pack connector interface to the outside world, it must be protected from external electrostatic discharge events. The PRES pin has integrated ESD protection to 2 kV. External protection can be added to support higher ESD protection requirements. The TPD1E10B06 single-channel ESD protection diode (U2) can protect the input up to 30 kV, and the R8 reduces the holding current to release the internal SCR in the event that it triggers.

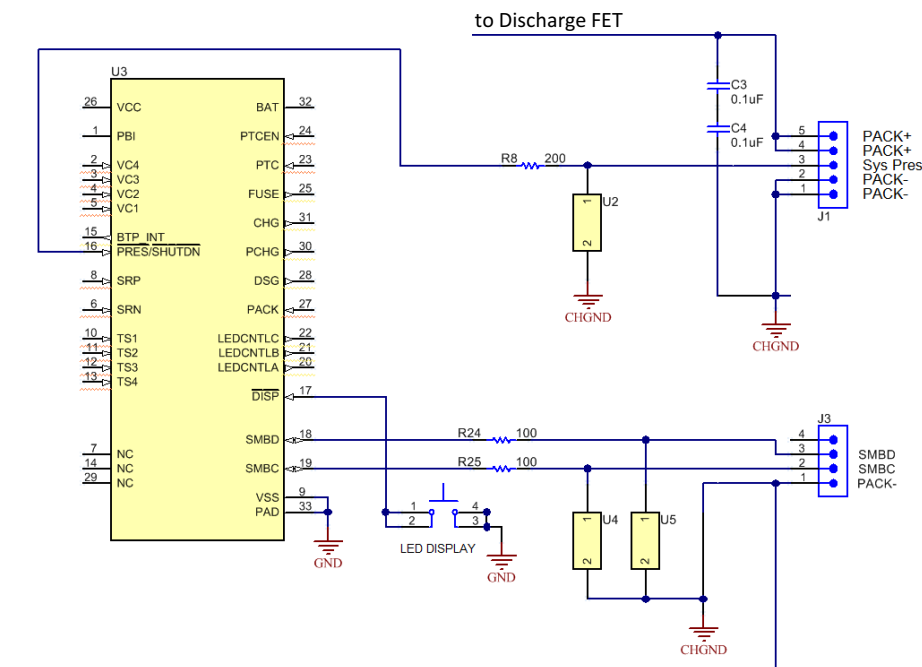

Figure 29. System Present ESD and Short Protection

9.2.2.2.4 SMBus Communication

The SMBus clock and data pins have integrated high-voltage ESD protection circuits; however, adding TPD1E10B06 ESD protection diodes (U4 and U5) and series resistors (R24 and R25) provides more robust ESD performance.

The SMBus clock and data lines have internal pulldown. When the gas gauge senses that both lines are low (such as during removal of the pack), the device performs auto-offset calibration and then goes into SLEEP mode to conserve power.

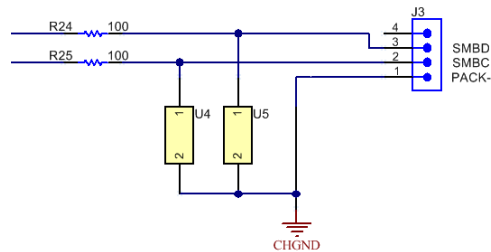

Figure 30. ESD Protection for SMBus Communication

9.2.2.2.5 FUSE Circuitry

The FUSE pin of the bq40z50-R2 device is designed to ignite the chemical fuse if one of the various safety criteria is violated. The FUSE pin also monitors the state of the secondary-voltage protection IC. Q5 ignites the chemical fuse when its gate is high. The 7-V output of the bq294700 is divided by R18 and R19, which provides adequate gate drive for Q5 while guarding against excessive back current into the bq294700 if the FUSE signal is high.

Using C7 is generally a good practice, especially for RFI immunity. C7 may be removed, if desired, because the chemical fuse is a comparatively slow device and is not affected by any sub-microsecond glitches that come from the FUSE output during the cell connection process.

If the AFEFUSE output is not used, it should be connected to VSS.

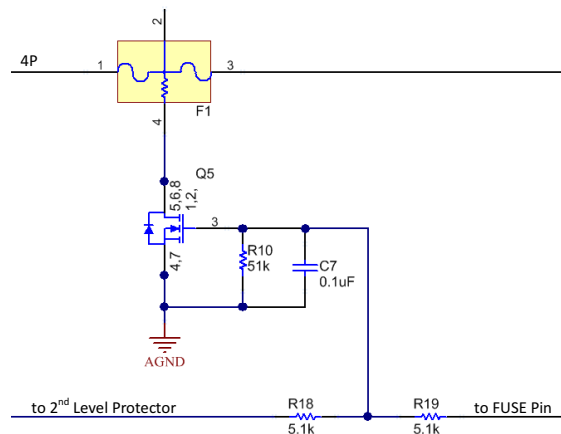

Figure 31. FUSE Circuit

When the bq40z50-R2 device is commanded to ignite the chemical fuse, the FUSE pin activates to give a typical 8-V output. The new design makes it possible to use a higher V_{gs} FET for Q5. This improves the robustness of the system, as well as widens the choices for Q5.

9.2.2.3 Secondary-Current Protection

The bq40z50-R2 device provides secondary overcurrent and short-circuit protection, cell balancing, cell voltage multiplexing, and voltage translation. The following section examines cell and battery inputs, pack and FET control, temperature output, and cell balancing.

9.2.2.3.1 Cell and Battery Inputs

Each cell input is conditioned with a simple RC filter, which provides ESD protection during cell connect and acts to filter unwanted voltage transients. The resistor value allows some trade-off for cell balancing versus safety protection.

The integrated cell balancing FETs enable the AFE to bypass cell current around a given cell or numerous cells, effectively balancing the entire battery stack. External series resistors placed between the cell connections and the VCx I/O pins set the balancing current magnitude. The internal FETs provide a 200- Ω resistance ($2\text{ V} < V_{DS} < 4\text{ V}$). Series input resistors between 100 Ω and 300 Ω are recommended for effective cell balancing.

The BAT input uses a diode (D1) to isolate and decouple it from the cells in the event of a transient dip in voltage caused by a short-circuit event.

Also, as described in [High-Current Path](#), the top and bottom nodes of the cells must be sensed at the battery connections with a Kelvin connection to prevent voltage sensing errors caused by a drop in the high-current PCB copper.

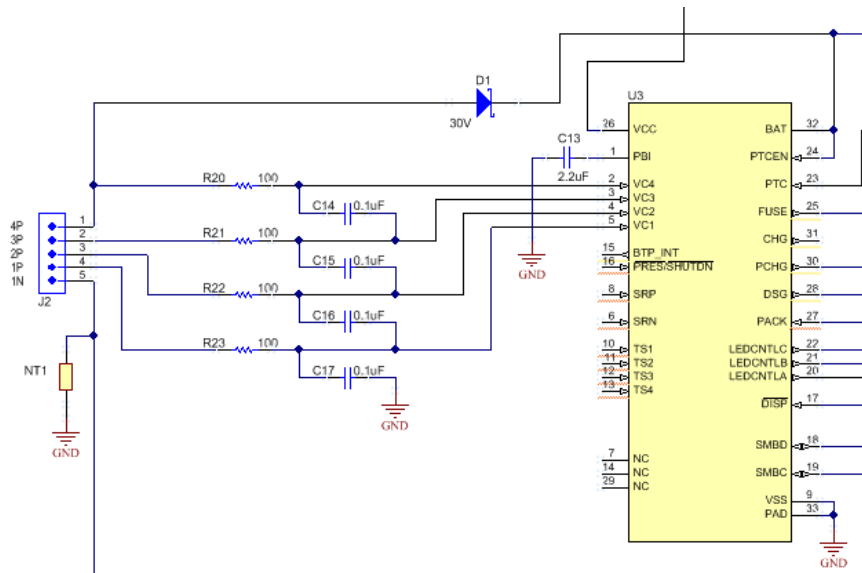

Figure 32. Cell and BAT Inputs

9.2.2.3.2 External Cell Balancing

Internal cell balancing can only support up to 10 mA. External cell balancing provide as another option for faster cell balancing. For details, refer to the application note, *Fast Cell Balancing Using External MOSFET (SLUA420)*.

9.2.2.3.3 PACK and FET Control

The PACK and V_{CC} inputs provide power to the bq40z50-R2 device from the charger. The PACK input also provides a method to measure and detect the presence of a charger. The PACK input uses a 10-k Ω resistor; whereas, the V_{CC} input uses an internal diode to guard against input transients and prevent a mis-operation of the gate driver during short-circuit events.

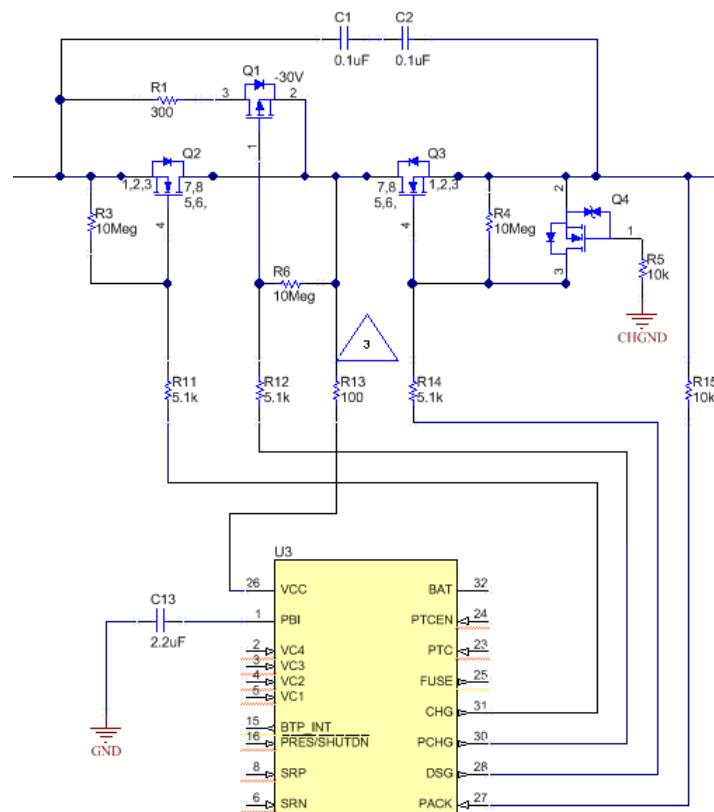

Figure 33. bq40z50-R2 PACK and FET Control

The N-channel charge and discharge FETs are controlled with 5.1-k Ω series gate resistors, which provide a switching time constant of a few microseconds. The 10-M Ω resistors ensure that the FETs are off in the event of an open connection to the FET drivers. Q4 is provided to protect the discharge FET (Q3) in the event of a reverse-connected charger. Without Q4, Q3 can be driven into its linear region and suffer severe damage if the PACK+ input becomes slightly negative.

Q4 turns on in that case to protect Q3 by shorting its gate to source. To use the simple ground gate circuit, the FET must have a low gate turn-on threshold. If it is desired to use a more standard device, such as the 2N7002 as the reference schematic, the gate should be biased up to 3.3 V with a high-value resistor. The bq40z50-R2 device has the capability to provide a current-limited charging path typically used for low battery voltage or low temperature charging. The bq40z50-R2 device uses an external P-channel, pre-charge FET controlled by PCHG.

9.2.2.3.4 Temperature Output

For the bq40z50-R2 device, TS1, TS2, TS3, and TS4 provide thermistor drive-under program control. Each pin can be enabled with an integrated 18-k Ω (typical) linearization pullup resistor to support the use of a 10-k Ω at 25°C (103) NTC external thermistor such as a Mitsubishi BN35-3H103. The reference design includes four 10-k Ω thermistors: RT2, RT3, RT4, and RT5. The bq40z50-R2 device supports up to four external thermistors. Connect unused thermistor pins to V_{SS} .

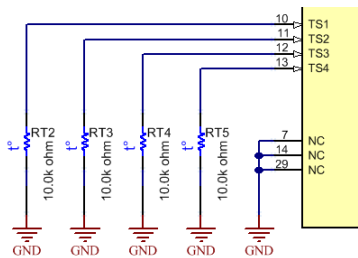

Figure 34. Thermistor Drive

9.2.2.3.5 LEDs

Three LED control outputs provide constant current sinks for the driving external LEDs. These outputs are configured to provide voltage and control for up to 5 LEDs. No external bias voltage is required. Unused LEDCNTL pins can remain open or they can be connected to V_{SS} . The DISP pin should be connected to V_{SS} , if the LED feature is not used.

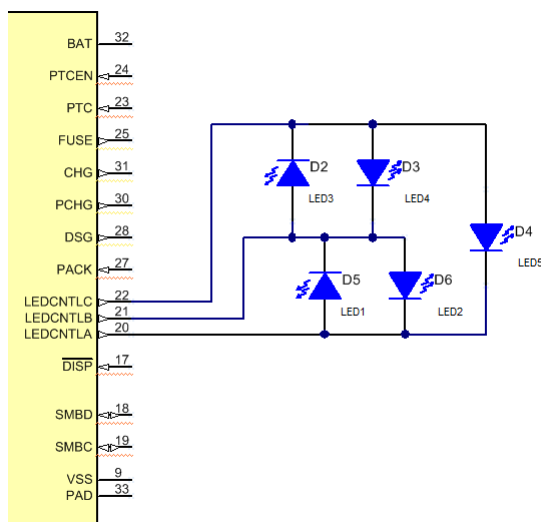

Figure 35. LEDs

9.2.2.3.6 Safety PTC Thermistor

The bq40z50-R2 device provides support for a safety PTC thermistor. The PTC thermistor is connected between the PTC and BAT pins. It can be placed close to the CHG/DSG FETs to monitor the temperature. The PTC pin monitors the voltage at the pin and will trip if the thermistor resistance exceeds the defined threshold. A PTC fault is one of the permanent failure modes. It can only be cleared by a POR.

To disable, connect PTC and PTCEN to V_{SS} .

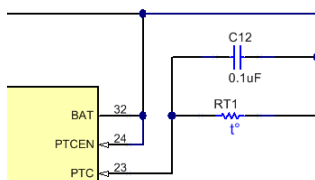
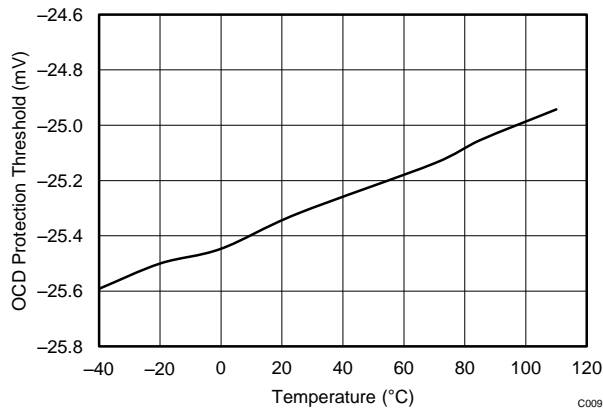

Figure 36. PTC Thermistor

9.2.3 Application Curves



Threshold setting is -25 mV.

Figure 37. Overcurrent Discharge Protection Threshold vs. Temperature

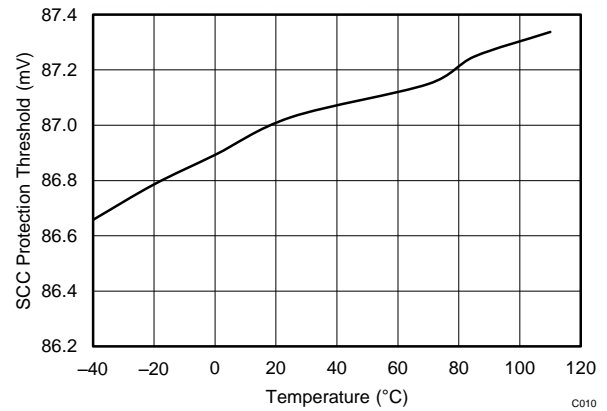

Threshold setting is 88.85 mV.

Figure 38. Short Circuit Charge Protection Threshold vs. Temperature

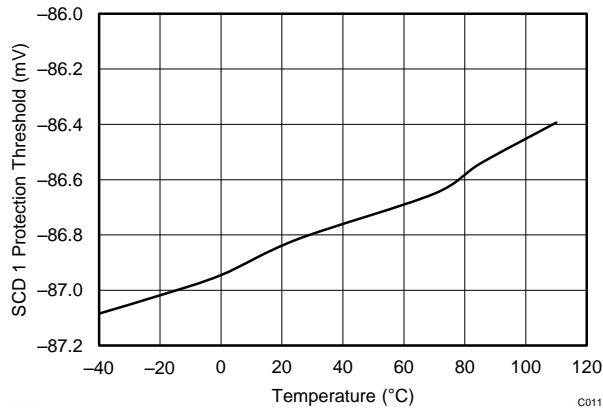

Threshold setting is -88.85 mV.

Figure 39. Short Circuit Discharge 1 Protection Threshold vs. Temperature

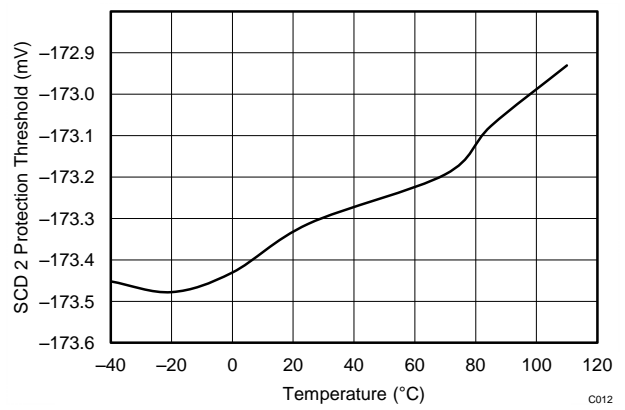

Threshold setting is -177.7 mV.

Figure 40. Short Circuit Discharge 2 Protection Threshold vs. Temperature

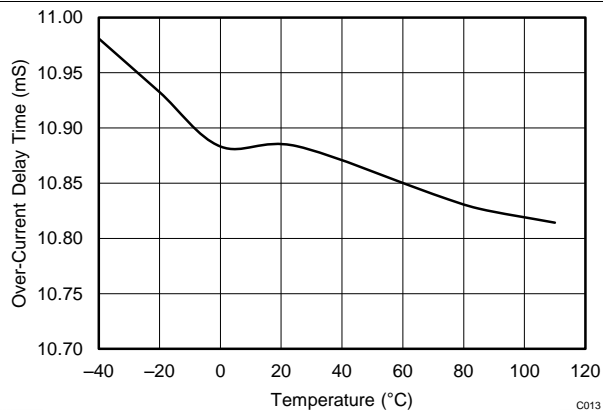

Threshold setting is 11 ms.

Figure 41. Overcurrent Delay Time vs. Temperature

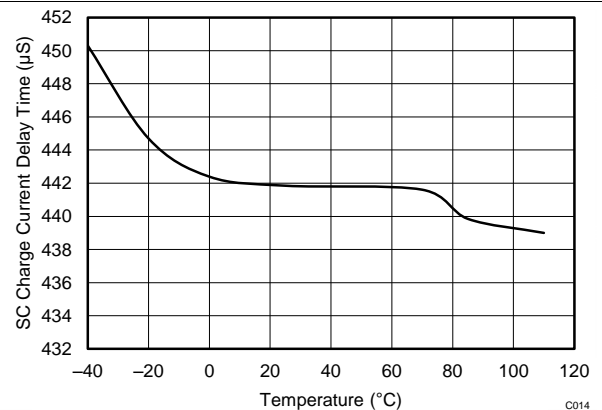

Threshold setting is 465 μs.

Figure 42. Short Circuit Charge Current Delay Time vs. Temperature

10 Power Supply Recommendations

The device manages its supply voltage dynamically according to the operation conditions. Normally, the BAT input is the primary power source to the device. The BAT pin should be connected to the positive termination of the battery stack. The input voltage for the BAT pin ranges from 2.2 V to 26 V.

The VCC pin is the secondary power input, which activates when the BAT voltage falls below minimum V_{CC} . This enables the device to source power from a charger (if present) connected to the PACK pin. The VCC pin should be connected to the common drain of the CHG and DSG FETs. The charger input should be connected to the PACK pin.

11 Layout

11.1 Layout Guidelines

A battery fuel gauge circuit board is a challenging environment due to the fundamental incompatibility of high-current traces and ultra-low current semiconductor devices. The best way to protect against unwanted trace-to-trace coupling is with a component placement, such as that shown in Figure 43, where the high-current section is on the opposite side of the board from the electronic devices. Clearly this is not possible in many situations due to mechanical constraints. Still, every attempt should be made to route high-current traces away from signal traces, which enter the bq40z50-R2 directly. IC references and registers can be disturbed and in rare cases damaged due to magnetic and capacitive coupling from the high-current path.

NOTE

During surge current and ESD events, the high-current traces appear inductive and can couple unwanted noise into sensitive nodes of the gas gauge electronics, as illustrated in Figure 44

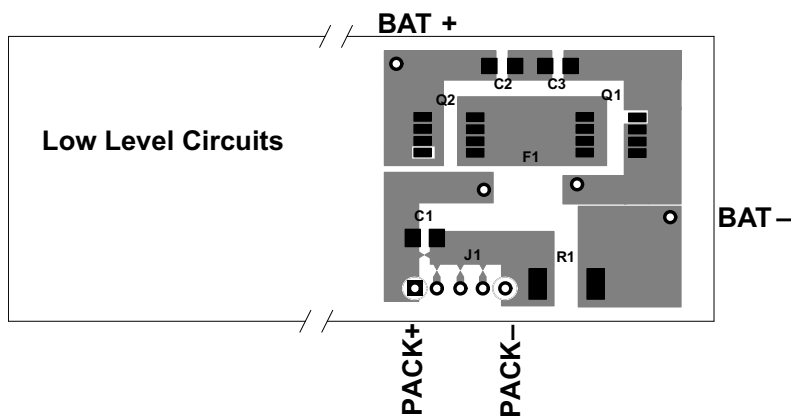

Copyright © 2016, Texas Instruments Incorporated

Figure 43. Separating High- and Low-Current Sections Provides an Advantage in Noise Immunity

Layout Guidelines (continued)

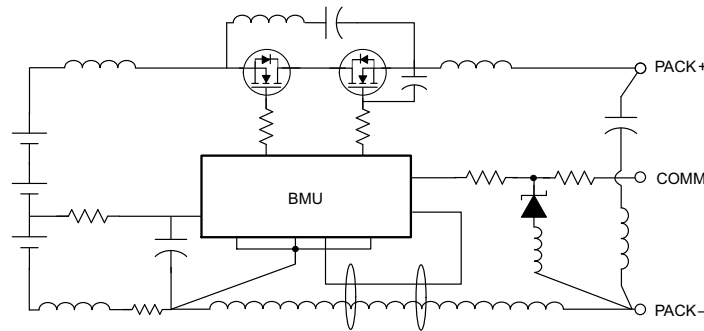

Copyright © 2016, Texas Instruments Incorporated

Figure 44. Avoid Close Spacing Between High-Current and Low-Level Signal Lines

Kelvin voltage sensing is extremely important in order to accurately measure current and top and bottom cell voltages. Place all filter components as close as possible to the device. Route the traces from the sense resistor in parallel to the filter circuit. Adding a ground plane around the filter network can add additional noise immunity. Figure 45 and Figure 46 demonstrates correct Kelvin current sensing.

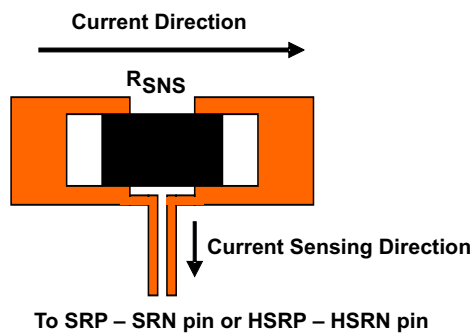

Figure 45. Sensing Resistor PCB Layout

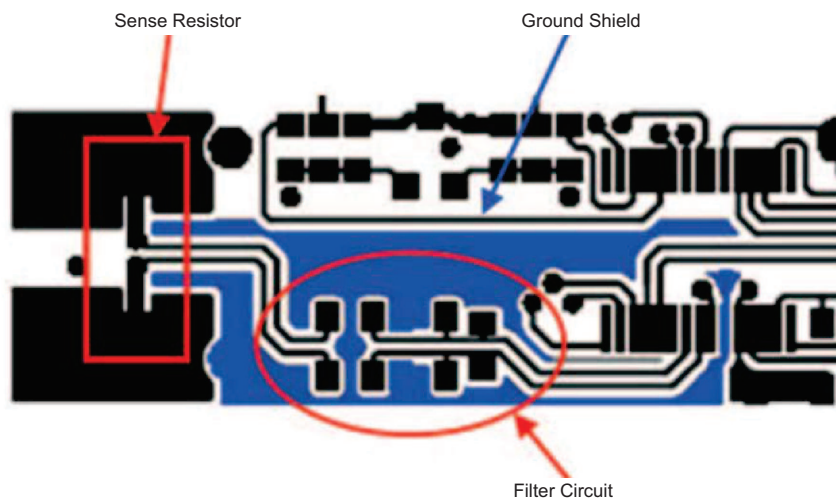
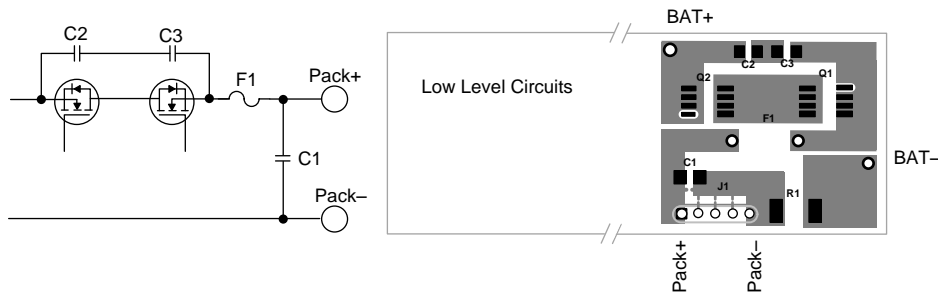

Figure 46. Sense Resistor, Ground Shield, and Filter Circuit Layout

Layout Guidelines (continued)

11.1.1 Protector FET Bypass and Pack Terminal Bypass Capacitors

Use wide copper traces to lower the inductance of the bypass capacitor circuit. [Figure 47](#) shows an example layout, demonstrating this technique.



Copyright © 2016, Texas Instruments Incorporated

Figure 47. Use Wide Copper Traces to Lower the Inductance of Bypass Capacitors C1, C2, and C3

11.1.2 ESD Spark Gap

Protect SMBus clock, data, and other communication lines from ESD with a spark gap at the connector. The pattern in [Figure 48](#) is recommended, with 0.2-mm spacing between the points.



Figure 48. Recommended Spark-Gap Pattern Helps Protect Communication Lines from ESD

11.2 Layout Example

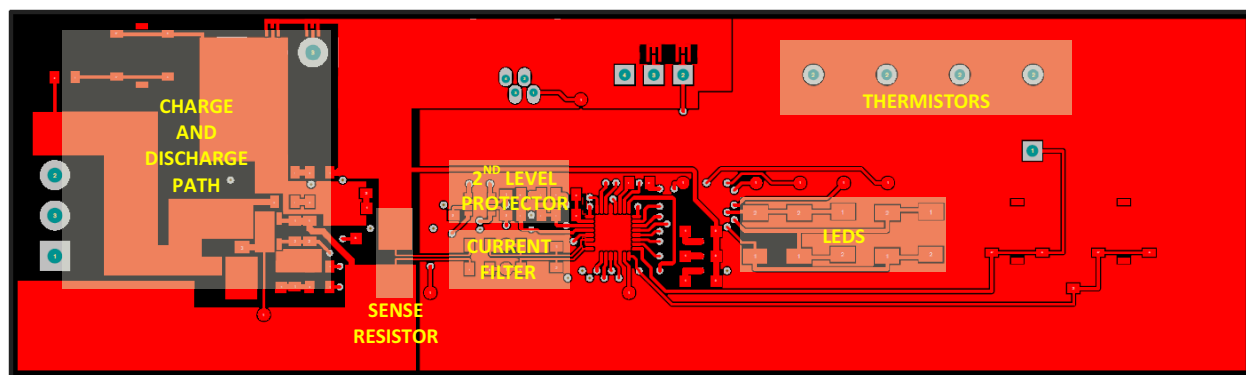

Figure 49. Top Layer

Layout Example (continued)

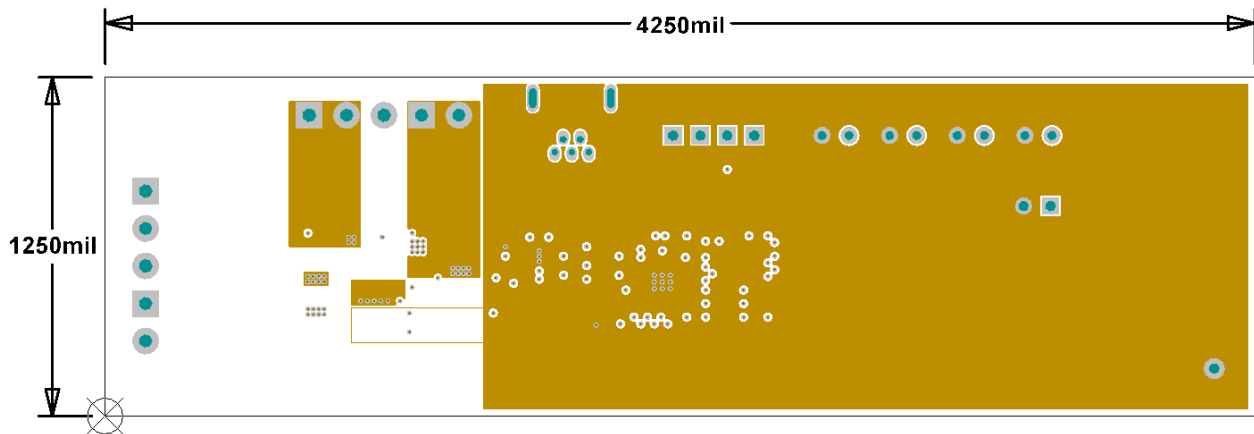

Figure 50. Internal Layer 1

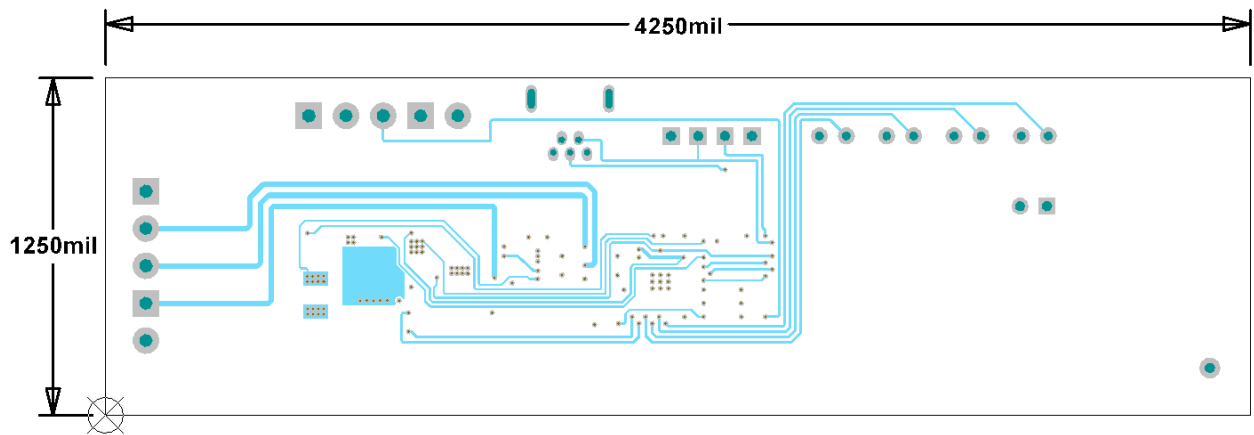

Figure 51. Internal Layer 2

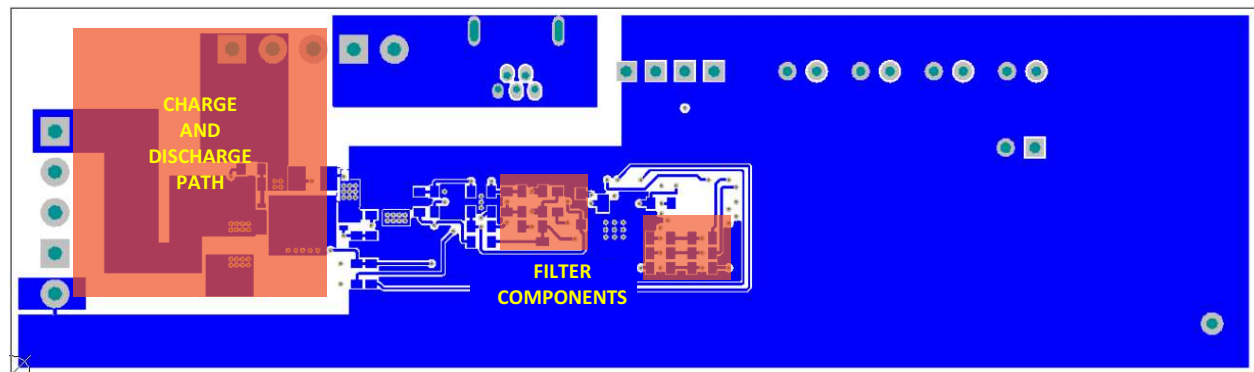

Figure 52. Bottom Layer

12 Device and Documentation Support

12.1 Documentation Support

12.1.1 Related Documentation

For related documentation, see the *bq40z50-R2 Technical Reference Manual* (SLUUBK0).

12.2 Receiving Notification of Documentation Updates

To receive notification of documentation updates, navigate to the device product folder on ti.com. In the upper right corner, click on **Alert me** to register and receive a weekly digest of any product information that has changed. For change details, review the revision history included in any revised document.

12.3 Community Resources

The following links connect to TI community resources. Linked contents are provided "AS IS" by the respective contributors. They do not constitute TI specifications and do not necessarily reflect TI's views; see TI's [Terms of Use](#).

TI E2E™ Online Community *TI's Engineer-to-Engineer (E2E) Community*. Created to foster collaboration among engineers. At e2e.ti.com, you can ask questions, share knowledge, explore ideas and help solve problems with fellow engineers.

Design Support *TI's Design Support* Quickly find helpful E2E forums along with design support tools and contact information for technical support.

12.4 Trademarks

Impedance Track, E2E are trademarks of Texas Instruments.
All other trademarks are the property of their respective owners.

12.5 Electrostatic Discharge Caution



This integrated circuit can be damaged by ESD. Texas Instruments recommends that all integrated circuits be handled with appropriate precautions. Failure to observe proper handling and installation procedures can cause damage.

ESD damage can range from subtle performance degradation to complete device failure. Precision integrated circuits may be more susceptible to damage because very small parametric changes could cause the device not to meet its published specifications.

12.6 Glossary

[SLYZ022](#) — *TI Glossary*.

This glossary lists and explains terms, acronyms, and definitions.

13 Mechanical, Packaging, and Orderable Information

The following pages include mechanical, packaging, and orderable information. This information is the most current data available for the designated devices. This data is subject to change without notice and revision of this document. For browser-based versions of this data sheet, refer to the left-hand navigation.

PACKAGING INFORMATION

Orderable Device	Status (1)	Package Type	Package Drawing	Pins	Package Qty	Eco Plan (2)	Lead/Ball Finish (6)	MSL Peak Temp (3)	Op Temp (°C)	Device Marking (4/5)	Samples
BQ40Z50RSMR-R2	ACTIVE	VQFN	RSM	32	3000	Green (RoHS & no Sb/Br)	CU NIPDAU	Level-2-260C-1 YEAR	-40 to 85	BQ40Z50	Samples
BQ40Z50RSMT-R2	ACTIVE	VQFN	RSM	32	250	Green (RoHS & no Sb/Br)	CU NIPDAU	Level-2-260C-1 YEAR	-40 to 85	BQ40Z50	Samples

(1) The marketing status values are defined as follows:

ACTIVE: Product device recommended for new designs.

LIFEBUY: TI has announced that the device will be discontinued, and a lifetime-buy period is in effect.

NRND: Not recommended for new designs. Device is in production to support existing customers, but TI does not recommend using this part in a new design.

PREVIEW: Device has been announced but is not in production. Samples may or may not be available.

OBSOLETE: TI has discontinued the production of the device.

(2) **RoHS:** TI defines "RoHS" to mean semiconductor products that are compliant with the current EU RoHS requirements for all 10 RoHS substances, including the requirement that RoHS substance do not exceed 0.1% by weight in homogeneous materials. Where designed to be soldered at high temperatures, "RoHS" products are suitable for use in specified lead-free processes. TI may reference these types of products as "Pb-Free".

RoHS Exempt: TI defines "RoHS Exempt" to mean products that contain lead but are compliant with EU RoHS pursuant to a specific EU RoHS exemption.

Green: TI defines "Green" to mean the content of Chlorine (Cl) and Bromine (Br) based flame retardants meet JS709B low halogen requirements of <=1000ppm threshold. Antimony trioxide based flame retardants must also meet the <=1000ppm threshold requirement.

(3) MSL, Peak Temp. - The Moisture Sensitivity Level rating according to the JEDEC industry standard classifications, and peak solder temperature.

(4) There may be additional marking, which relates to the logo, the lot trace code information, or the environmental category on the device.

(5) Multiple Device Markings will be inside parentheses. Only one Device Marking contained in parentheses and separated by a "~" will appear on a device. If a line is indented then it is a continuation of the previous line and the two combined represent the entire Device Marking for that device.

(6) Lead/Ball Finish - Orderable Devices may have multiple material finish options. Finish options are separated by a vertical ruled line. Lead/Ball Finish values may wrap to two lines if the finish value exceeds the maximum column width.

Important Information and Disclaimer:The information provided on this page represents TI's knowledge and belief as of the date that it is provided. TI bases its knowledge and belief on information provided by third parties, and makes no representation or warranty as to the accuracy of such information. Efforts are underway to better integrate information from third parties. TI has taken and continues to take reasonable steps to provide representative and accurate information but may not have conducted destructive testing or chemical analysis on incoming materials and chemicals. TI and TI suppliers consider certain information to be proprietary, and thus CAS numbers and other limited information may not be available for release.

In no event shall TI's liability arising out of such information exceed the total purchase price of the TI part(s) at issue in this document sold by TI to Customer on an annual basis.

TAPE AND REEL INFORMATION



QUADRANT ASSIGNMENTS FOR PIN 1 ORIENTATION IN TAPE



*All dimensions are nominal

Device	Package Type	Package Drawing	Pins	SPQ	Reel Diameter (mm)	Reel Width W1 (mm)	A0 (mm)	B0 (mm)	K0 (mm)	P1 (mm)	W (mm)	Pin1 Quadrant
BQ40Z50RSMR-R2	VQFN	RSM	32	3000	330.0	12.4	4.25	4.25	1.15	8.0	12.0	Q2
BQ40Z50RSMT-R2	VQFN	RSM	32	250	180.0	12.4	4.25	4.25	1.15	8.0	12.0	Q2

TAPE AND REEL BOX DIMENSIONS



*All dimensions are nominal

Device	Package Type	Package Drawing	Pins	SPQ	Length (mm)	Width (mm)	Height (mm)
BQ40Z50RSMR-R2	VQFN	RSM	32	3000	367.0	367.0	35.0
BQ40Z50RSMT-R2	VQFN	RSM	32	250	210.0	185.0	35.0

RSM (S-PVQFN-N32)

PLASTIC QUAD FLATPACK NO-LEAD

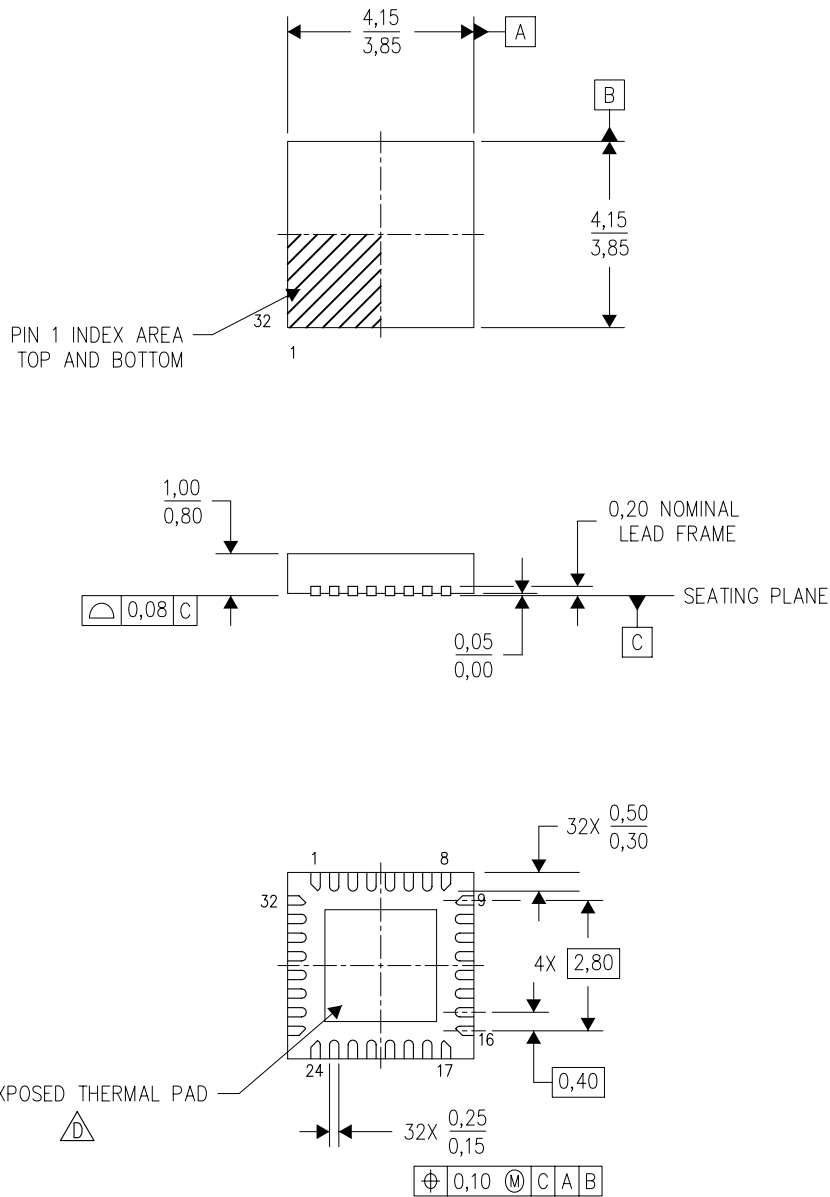

4207560/B 03/10

- NOTES:
- A. All linear dimensions are in millimeters. Dimensioning and tolerancing per ASME Y14.5M-1994.
 - B. This drawing is subject to change without notice.
 - C. QFN (Quad Flatpack No-Lead) Package configuration.
 -  The package thermal pad must be soldered to the board for thermal and mechanical performance. See the Product Data Sheet for details regarding the exposed thermal pad dimensions.

RSM (S-PVQFN-N32)

PLASTIC QUAD FLATPACK NO-LEAD

THERMAL INFORMATION

This package incorporates an exposed thermal pad that is designed to be attached directly to an external heatsink. The thermal pad must be soldered directly to the printed circuit board (PCB). After soldering, the PCB can be used as a heatsink. In addition, through the use of thermal vias, the thermal pad can be attached directly to the appropriate copper plane shown in the electrical schematic for the device, or alternatively, can be attached to a special heatsink structure designed into the PCB. This design optimizes the heat transfer from the integrated circuit (IC).

For information on the Quad Flatpack No-Lead (QFN) package and its advantages, refer to Application Report, QFN/SON PCB Attachment, Texas Instruments Literature No. SLUA271. This document is available at www.ti.com.

The exposed thermal pad dimensions for this package are shown in the following illustration.

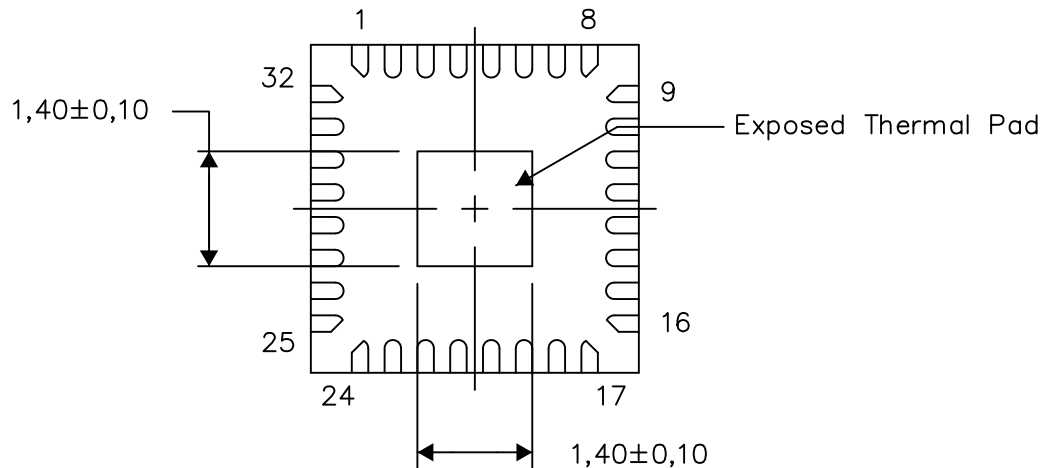

Bottom View

Exposed Thermal Pad Dimensions

4207868-3/1 07/14

NOTE: All linear dimensions are in millimeters

RSM (S-PVQFN-N32)

PLASTIC QUAD FLATPACK NO-LEAD

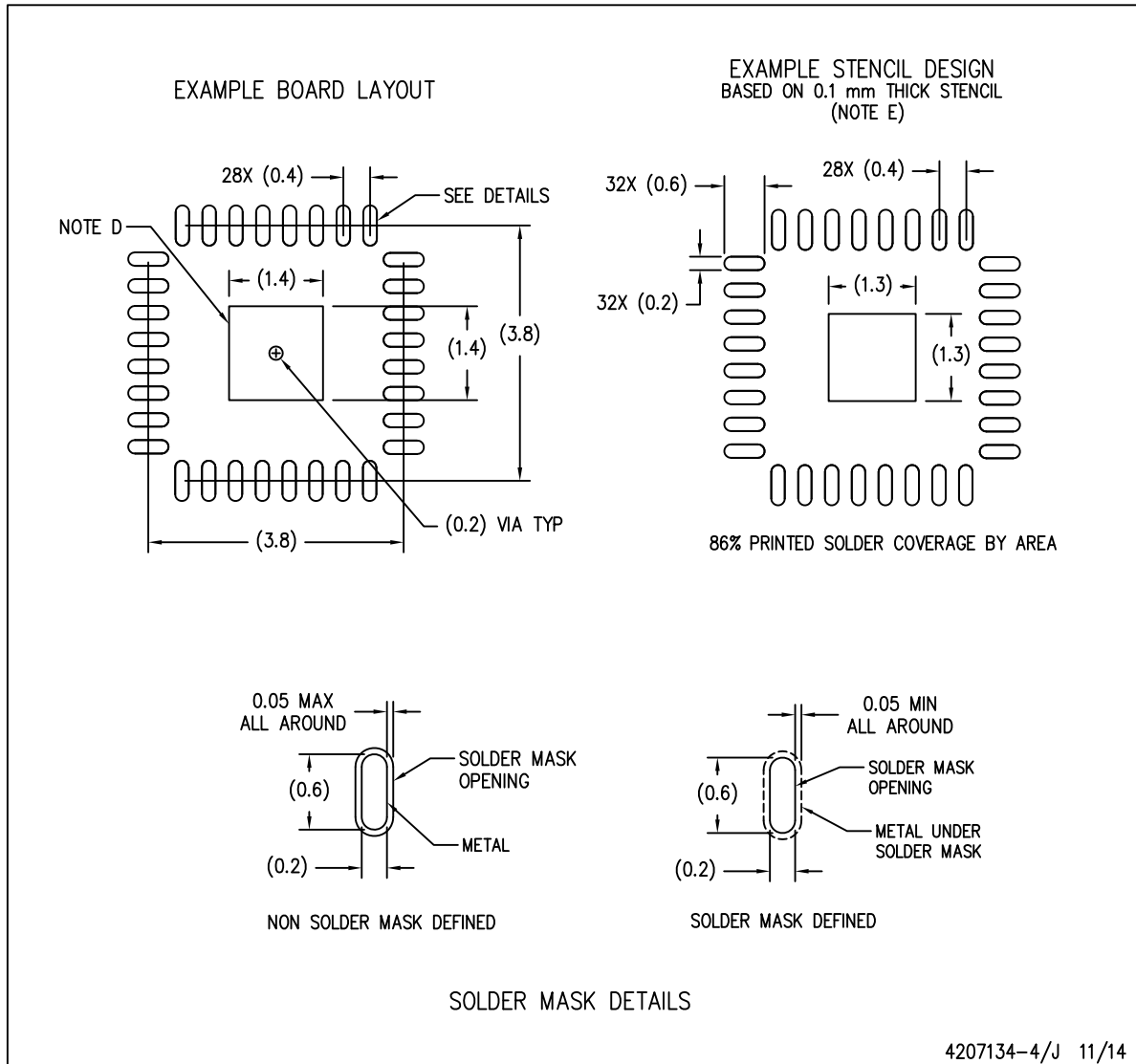

- NOTES:
- All linear dimensions are in millimeters.
 - This drawing is subject to change without notice.
 - Publication IPC-7351 is recommended for alternate designs.
 - This package is designed to be soldered to a thermal pad on the board. Refer to Application Note, Quad Flat-Pack Packages, Texas Instruments Literature No. SLUA271, and also the Product Data Sheets for specific thermal information, via requirements, and recommended board layout. These documents are available at www.ti.com <<http://www.ti.com>>.
 - Laser cutting apertures with trapezoidal walls and also rounding corners will offer better paste release. Customers should contact their board assembly site for stencil design recommendations. Refer to IPC 7525 for stencil design considerations.
 - Customers should contact their board fabrication site for recommended solder mask tolerances and via tenting recommendations for vias placed in the thermal pad.

IMPORTANT NOTICE

Texas Instruments Incorporated (TI) reserves the right to make corrections, enhancements, improvements and other changes to its semiconductor products and services per JESD46, latest issue, and to discontinue any product or service per JESD48, latest issue. Buyers should obtain the latest relevant information before placing orders and should verify that such information is current and complete.

TI's published terms of sale for semiconductor products (<http://www.ti.com/sc/docs/stdterms.htm>) apply to the sale of packaged integrated circuit products that TI has qualified and released to market. Additional terms may apply to the use or sale of other types of TI products and services.

Reproduction of significant portions of TI information in TI data sheets is permissible only if reproduction is without alteration and is accompanied by all associated warranties, conditions, limitations, and notices. TI is not responsible or liable for such reproduced documentation. Information of third parties may be subject to additional restrictions. Resale of TI products or services with statements different from or beyond the parameters stated by TI for that product or service voids all express and any implied warranties for the associated TI product or service and is an unfair and deceptive business practice. TI is not responsible or liable for any such statements.

Buyers and others who are developing systems that incorporate TI products (collectively, "Designers") understand and agree that Designers remain responsible for using their independent analysis, evaluation and judgment in designing their applications and that Designers have full and exclusive responsibility to assure the safety of Designers' applications and compliance of their applications (and of all TI products used in or for Designers' applications) with all applicable regulations, laws and other applicable requirements. Designer represents that, with respect to their applications, Designer has all the necessary expertise to create and implement safeguards that (1) anticipate dangerous consequences of failures, (2) monitor failures and their consequences, and (3) lessen the likelihood of failures that might cause harm and take appropriate actions. Designer agrees that prior to using or distributing any applications that include TI products, Designer will thoroughly test such applications and the functionality of such TI products as used in such applications.

TI's provision of technical, application or other design advice, quality characterization, reliability data or other services or information, including, but not limited to, reference designs and materials relating to evaluation modules, (collectively, "TI Resources") are intended to assist designers who are developing applications that incorporate TI products; by downloading, accessing or using TI Resources in any way, Designer (individually or, if Designer is acting on behalf of a company, Designer's company) agrees to use any particular TI Resource solely for this purpose and subject to the terms of this Notice.

TI's provision of TI Resources does not expand or otherwise alter TI's applicable published warranties or warranty disclaimers for TI products, and no additional obligations or liabilities arise from TI providing such TI Resources. TI reserves the right to make corrections, enhancements, improvements and other changes to its TI Resources. TI has not conducted any testing other than that specifically described in the published documentation for a particular TI Resource.

Designer is authorized to use, copy and modify any individual TI Resource only in connection with the development of applications that include the TI product(s) identified in such TI Resource. NO OTHER LICENSE, EXPRESS OR IMPLIED, BY ESTOPPEL OR OTHERWISE TO ANY OTHER TI INTELLECTUAL PROPERTY RIGHT, AND NO LICENSE TO ANY TECHNOLOGY OR INTELLECTUAL PROPERTY RIGHT OF TI OR ANY THIRD PARTY IS GRANTED HEREIN, including but not limited to any patent right, copyright, mask work right, or other intellectual property right relating to any combination, machine, or process in which TI products or services are used. Information regarding or referencing third-party products or services does not constitute a license to use such products or services, or a warranty or endorsement thereof. Use of TI Resources may require a license from a third party under the patents or other intellectual property of the third party, or a license from TI under the patents or other intellectual property of TI.

TI RESOURCES ARE PROVIDED "AS IS" AND WITH ALL FAULTS. TI DISCLAIMS ALL OTHER WARRANTIES OR REPRESENTATIONS, EXPRESS OR IMPLIED, REGARDING RESOURCES OR USE THEREOF, INCLUDING BUT NOT LIMITED TO ACCURACY OR COMPLETENESS, TITLE, ANY EPIDEMIC FAILURE WARRANTY AND ANY IMPLIED WARRANTIES OF MERCHANTABILITY, FITNESS FOR A PARTICULAR PURPOSE, AND NON-INFRINGEMENT OF ANY THIRD PARTY INTELLECTUAL PROPERTY RIGHTS. TI SHALL NOT BE LIABLE FOR AND SHALL NOT DEFEND OR INDEMNIFY DESIGNER AGAINST ANY CLAIM, INCLUDING BUT NOT LIMITED TO ANY INFRINGEMENT CLAIM THAT RELATES TO OR IS BASED ON ANY COMBINATION OF PRODUCTS EVEN IF DESCRIBED IN TI RESOURCES OR OTHERWISE. IN NO EVENT SHALL TI BE LIABLE FOR ANY ACTUAL, DIRECT, SPECIAL, COLLATERAL, INDIRECT, PUNITIVE, INCIDENTAL, CONSEQUENTIAL OR EXEMPLARY DAMAGES IN CONNECTION WITH OR ARISING OUT OF TI RESOURCES OR USE THEREOF, AND REGARDLESS OF WHETHER TI HAS BEEN ADVISED OF THE POSSIBILITY OF SUCH DAMAGES.

Unless TI has explicitly designated an individual product as meeting the requirements of a particular industry standard (e.g., ISO/TS 16949 and ISO 26262), TI is not responsible for any failure to meet such industry standard requirements.

Where TI specifically promotes products as facilitating functional safety or as compliant with industry functional safety standards, such products are intended to help enable customers to design and create their own applications that meet applicable functional safety standards and requirements. Using products in an application does not by itself establish any safety features in the application. Designers must ensure compliance with safety-related requirements and standards applicable to their applications. Designer may not use any TI products in life-critical medical equipment unless authorized officers of the parties have executed a special contract specifically governing such use. Life-critical medical equipment is medical equipment where failure of such equipment would cause serious bodily injury or death (e.g., life support, pacemakers, defibrillators, heart pumps, neurostimulators, and implantables). Such equipment includes, without limitation, all medical devices identified by the U.S. Food and Drug Administration as Class III devices and equivalent classifications outside the U.S.

TI may expressly designate certain products as completing a particular qualification (e.g., Q100, Military Grade, or Enhanced Product). Designers agree that it has the necessary expertise to select the product with the appropriate qualification designation for their applications and that proper product selection is at Designers' own risk. Designers are solely responsible for compliance with all legal and regulatory requirements in connection with such selection.

Designer will fully indemnify TI and its representatives against any damages, costs, losses, and/or liabilities arising out of Designer's non-compliance with the terms and provisions of this Notice.