

BGA231N7

Silicon Germanium GNSS Low Noise Amplifier

Data Sheet

Revision 1.0, 2013-01-30

Edition 2013-01-30

**Published by
Infineon Technologies AG
81726 Munich, Germany**

**© 2013 Infineon Technologies AG
All Rights Reserved.**

Legal Disclaimer

The information given in this document shall in no event be regarded as a guarantee of conditions or characteristics. With respect to any examples or hints given herein, any typical values stated herein and/or any information regarding the application of the device, Infineon Technologies hereby disclaims any and all warranties and liabilities of any kind, including without limitation, warranties of non-infringement of intellectual property rights of any third party.

Information

For further information on technology, delivery terms and conditions and prices, please contact the nearest Infineon Technologies Office (www.infineon.com).

Warnings

Due to technical requirements, components may contain dangerous substances. For information on the types in question, please contact the nearest Infineon Technologies Office.

Infineon Technologies components may be used in life-support devices or systems only with the express written approval of Infineon Technologies, if a failure of such components can reasonably be expected to cause the failure of that life-support device or system or to affect the safety or effectiveness of that device or system. Life support devices or systems are intended to be implanted in the human body or to support and/or maintain and sustain and/or protect human life. If they fail, it is reasonable to assume that the health of the user or other persons may be endangered.

Revision History

Page or Item	Subjects (major changes since previous revision)
Revision 1.0, 2013-01-30	
all	Initial version for new packages TSNP-7-1 / TSNP-7-2

Trademarks of Infineon Technologies AG

AURIX™, C166™, CanPAK™, CIPOS™, CIPURSE™, EconoPACK™, CoolMOS™, CoolSET™, CORECONTROL™, CROSSAVE™, DAVE™, DI-POL™, EasyPIM™, EconoBRIDGE™, EconoDUAL™, EconoPIM™, EconoPACK™, EiceDRIVER™, eupec™, FCOS™, HITFET™, HybridPACK™, I²RF™, ISOFACE™, IsoPACK™, MIPAQ™, ModSTACK™, my-d™, NovalithIC™, OptiMOS™, ORIGAT™, POWERCODE™; PRIMARION™, PrimePACK™, PrimeSTACK™, PRO-SIL™, PROFET™, RASIC™, ReverSave™, SatRIC™, SIEGET™, SINDRION™, SIPMOS™, SmartLEWIS™, SOLID FLASH™, TEMPFET™, thinQ!™, TRENCHSTOP™, TriCore™.

Other Trademarks

Advance Design System™ (ADS) of Agilent Technologies, AMBA™, ARM™, MULTI-ICE™, KEIL™, PRIMECELL™, REALVIEW™, THUMB™, μVision™ of ARM Limited, UK. AUTOSAR™ is licensed by AUTOSAR development partnership. Bluetooth™ of Bluetooth SIG Inc. CAT-iq™ of DECT Forum. COLOSSUS™, FirstGPS™ of Trimble Navigation Ltd. EMV™ of EMVCo, LLC (Visa Holdings Inc.). EPCOS™ of Epcos AG. FLEXGO™ of Microsoft Corporation. FlexRay™ is licensed by FlexRay Consortium. HYPERTERMINAL™ of Hilgraeve Incorporated. IEC™ of Commission Electrotechnique Internationale. IrDA™ of Infrared Data Association Corporation. ISO™ of INTERNATIONAL ORGANIZATION FOR STANDARDIZATION. MATLAB™ of MathWorks, Inc. MAXIM™ of Maxim Integrated Products, Inc. MICROTEC™, NUCLEUS™ of Mentor Graphics Corporation. MIPI™ of MIPI Alliance, Inc. MIPS™ of MIPS Technologies, Inc., USA. muRata™ of MURATA MANUFACTURING CO., MICROWAVE OFFICE™ (MWO) of Applied Wave Research Inc., OmniVision™ of OmniVision Technologies, Inc. Openwave™ Openwave Systems Inc. RED HAT™ Red Hat, Inc. RFMD™ RF Micro Devices, Inc. SIRIUS™ of Sirius Satellite Radio Inc. SOLARIS™ of Sun Microsystems, Inc. SPANSION™ of Spansion LLC Ltd. Symbian™ of Symbian Software Limited. TAIYO YUDEN™ of Taiyo Yuden Co. TEAKLITE™ of CEVA, Inc. TEKTRONIX™ of Tektronix Inc. TOKO™ of TOKO KABUSHIKI KAISHA TA. UNIX™ of X/Open Company Limited. VERILOG™, PALLADIUM™ of Cadence Design Systems, Inc. VLYNQ™ of Texas Instruments Incorporated. VXWORKS™, WIND RIVER™ of WIND RIVER SYSTEMS, INC. ZETEX™ of Diodes Zetex Limited.

Last Trademarks Update 2011-11-11

Table of Contents

	Table of Contents	4
	List of Figures	5
	List of Tables	6
	Features	7
1	Maximum Ratings	9
2	Electrical Characteristics	10
3	Application Information	12
4	Package Information	13
4.1	TSNP-7-1	13
4.2	TSNP-7-2	14
4.3	Footprint Recommendation	15

List of Figures

Figure 1	Block Diagram	8
Figure 2	Application Schematic BGA231N7	12
Figure 3	Package Dimensions for TSNP-7-1	13
Figure 4	Marking Layout TSNP-7-1 (top view)	13
Figure 5	Tape & Reel Dimensions TSNP-7-1 (Ø reel 180, pieces/reel 7500)	13
Figure 6	Package Dimensions for TSNP-7-2	14
Figure 7	Marking Layout TSNP-7-2 (top view)	14
Figure 8	Tape & Reel Dimensions TSNP-7-2 (Ø reel 180, pieces/reel 6000)	14
Figure 9	Footprint Recommendation 1 for TSNP-7-1 / TSNP-7-2	15
Figure 10	Footprint Recommendation 2 for TSNP-7-1 / TSNP-7-2	15

List of Tables

Table 1	Pin Definition and Function	8
Table 2	Maximum Ratings	9
Table 3	Thermal Resistance	9
Table 4	Electrical Characteristics: $T_A = 25\text{ °C}$, $V_{CC} = 2.8\text{ V}$, $V_{PON,ON} = 2.8\text{ V}$, $V_{PON,OFF} = 0\text{ V}$, $f = 1550 - 1615\text{ MHz}$ (GPS / Glonass / Beidou / Galileo)	10
Table 5	Electrical Characteristics: $T_A = 25\text{ °C}$, $V_{CC} = 1.8\text{ V}$, $V_{PON,ON} = 1.8\text{ V}$, $V_{PON,OFF} = 0\text{ V}$, $f = 1550 - 1615\text{ MHz}$ (GPS / Glonass / Beidou / Galileo)	11
Table 6	Bill of Materials	12

Features

- Insertion power gain: 16.0 dB
- High out of band input 3rd-order intercept point at input: +5 dBm
- High input 1 dB compression point: -5 dBm
- Low noise figure: 0.75 dB
- Low current consumption: 4.4 mA
- Operating frequencies: 1550 - 1615 MHz
- Supply voltage: 1.5 V to 3.6 V
- Digital on/off switch (1V logic high level)
- Tiny TSNP-7-1 / TSNP-7-2 leadless package
- B7HF Silicon Germanium technology
- RF output internally matched to 50 Ω
- Only 3 external SMD components necessary
- 2 kV HBM ESD protection (including AI-pin)
- Pb-free (RoHS compliant) package



TSNP-7-1



TSNP-7-2

Application

- Ideal for all Global Navigation Satellite Systems (GNSS) like GPS, Galileo, GLONASS, COMPASS and others

Description

The BGA231N7 is a front-end low noise amplifier for Global Navigation Satellite Systems (GNSS) from 1550 MHz to 1615 MHz like GPS, Galileo, GLONASS, COMPASS and others. The LNA provides 16.0 dB gain and 0.75 dB noise figure at a current consumption of 4.4 mA in the application configuration described in [Chapter 3](#). The BGA231N7 is based upon Infineon Technologies' B7HF Silicon Germanium technology. It operates from 1.5 V to 3.6 V supply voltage.

Product Name	Marking	Package
BGA231N7	BD	TSNP-7-1 / TSNP-7-2

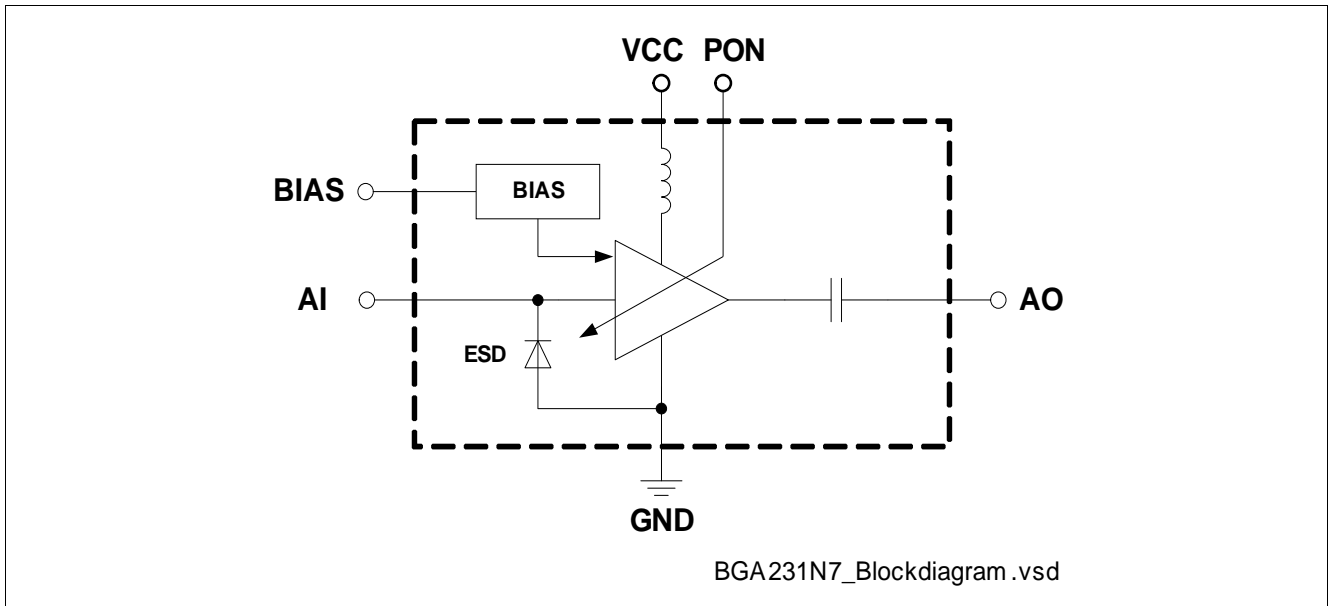

Figure 1 Block Diagram

Table 1 Pin Definition and Function

Pin No.	Name	Function
1	PON	Power on control
2	AI	LNA input
3	BIAS	DC bias
4	n.c.	not connected
5	AO	LNA output
6	VCC	DC Supply
7	GND	RF and DC ground

1 Maximum Ratings

Table 2 Maximum Ratings

Parameter	Symbol	Values			Unit	Note / Test Condition
		Min.	Typ.	Max.		
Voltage at pin VCC	V_{CC}	-0.3	–	3.6	V	1)
Voltage at pin AI	V_{AI}	-0.3	–	0.9	V	–
Voltage at pin BIAS	V_{BIAS}	-0.3	–	0.9	V	–
Voltage at pin AO	V_{AO}	-0.3	–	$V_{CC} + 0.3$	V	–
Voltage at pin PON	V_{PON}	-0.3	–	$V_{CC} + 0.3$	V	–
Voltage at pin VSS	V_{SS}	-0.3	–	0.3	V	–
Current into pin VCC	I_{CC}	–	–	20	mA	–
RF input power	P_{IN}	–	–	0	dBm	–
Total power dissipation, $T_S < 129\text{ °C}^2)$	T_J	–	–	72	mW	–
Junction temperature	P_{tot}	–	–	150	°C	–
Ambient temperature range	T_A	-40	–	85	°C	–
Storage temperature range	T_{STG}	-65	–	150	°C	–
ESD capability all pins	V_{ESD_HBM}	–	–	2000	V	according to JESD22A-114

1) All voltages refer to VSS-Node unless otherwise noted

2) T_S is measured on the ground lead at the soldering point

Attention: Stresses above the max. values listed here may cause permanent damage to the device. Exposure to absolute maximum rating conditions for extended periods may affect device reliability. Maximum ratings are absolute ratings; exceeding only one of these values may cause irreversible damage to the integrated circuit.

Thermal Resistance

Table 3 Thermal Resistance

Parameter	Symbol	Value	Unit
Junction - soldering point ¹⁾	R_{thJS}	291	K/W

1) For calculation of R_{thJA} please refer to Application Note Thermal Resistance

2 Electrical Characteristics

Table 4 Electrical Characteristics:¹⁾ $T_A = 25\text{ °C}$, $V_{CC} = 2.8\text{ V}$, $V_{PON,ON} = 2.8\text{ V}$, $V_{PON,OFF} = 0\text{ V}$,
 $f = 1550 - 1615\text{ MHz}$ (GPS / Glonass / Beidou / Galileo)

Parameter	Symbol	Values			Unit	Note / Test Condition
		Min.	Typ.	Max.		
Supply voltage	V_{CC}	1.5	–	3.6	V	–
Supply current	I_{CC}	–	4.4	–	mA	ON-mode
		–	0.2	3	μA	OFF-mode
Power On voltage	V_{pon}	1.0	–	V_{CC}	V	ON-mode
		0	–	0.4	V	OFF-mode
Power On current	I_{pon}	–	5	–	μA	ON-mode
		–	–	1	μA	OFF-mode
Insertion power gain	$ S_{21} ^2$	–	16.0	–	dB	
Noise figure ²⁾	NF	–	0.75	1.3	dB	$Z_S = 50\ \Omega$
Input return loss	RL_{in}	–	10	–	dB	
Output return loss	RL_{out}	–	16	–	dB	
Reverse isolation	$1/ S_{12} ^2$	–	23	–	dB	
Power gain settling time ³⁾	t_S	–	5	–	μs	OFF- to ON-mode
		–	5	–	μs	ON- to OFF-mode
Inband input 1 dB-compression point	IP_{1dB}	–	-5	–	dBm	
Inband input 3 rd -order intercept point ⁴⁾	IIP_3	–	0	–	dBm	$f_1 = 1575\text{ MHz}$ $f_2 = f_1 \pm 1\text{ MHz}$
Out of band input 3rd order intercept point ⁵⁾	IIP_{3oob}	–	+5	–	dBm	$f_1 = 1712.7\text{ MHz}$ $f_2 = 1850\text{ MHz}$
Stability	k	–	> 1	–		$f = 20\text{ MHz} \dots 10\text{ GHz}$

1) Based on the application described in chapter 3

2) PCB losses are subtracted

3) To be within 1 dB of the final gain OFF- to ON-mode; to be within 3 dB of the final gain ON- to OFF-mode

4) Input Power = -30 dBm for each tone

5) Input Power = -20 dBm for each tone

Electrical Characteristics

Table 5 Electrical Characteristics:¹⁾ $T_A = 25\text{ °C}$, $V_{CC} = 1.8\text{ V}$, $V_{PON,ON} = 1.8\text{ V}$, $V_{PON,OFF} = 0\text{ V}$,
 $f = 1550 - 1615\text{ MHz}$ (GPS / Glonass / Beidou / Galileo)

Parameter	Symbol	Values			Unit	Note / Test Condition
		Min.	Typ.	Max.		
Supply voltage	V_{CC}	1.5	–	3.6	V	–
Supply current	I_{CC}	–	4.4	–	mA	ON-mode
		–	0.2	3	μA	OFF-mode
Gain switch control voltage	V_{pon}	1.0	–	V_{CC}	V	ON-mode
		0	–	0.4	V	OFF-mode
Gain switch control current	I_{pon}	–	5	–	μA	ON-mode
		–	–	1	μA	OFF-mode
Insertion power gain	$ S_{21} ^2$	–	16.0	–	dB	
Noise figure ²⁾	NF	–	0.75	1.3	dB	$Z_S = 50\ \Omega$
Input return loss	RL_{in}	–	10	–	dB	
Output return loss	RL_{out}	–	16	–	dB	
Reverse isolation	$1/ S_{12} ^2$	–	23	–	dB	
Power gain settling time ³⁾	t_S	–	5	–	μs	OFF- to ON-mode
		–	5	–	μs	ON- to OFF-mode
Inband input 1 dB-compression point	IP_{1dB}	–	-8	–	dBm	
Inband input 3 rd -order intercept point ⁴⁾	IIP_3	–	0	–	dBm	$f_1 = 1575\text{ MHz}$ $f_2 = f_1 \pm 1\text{ MHz}$
Out of band input 3rd order intercept point ⁵⁾	IIP_{3oob}	–	+5	–	dBm	$f_1 = 1712.7\text{ MHz}$ $f_2 = 1850\text{ MHz}$
Stability	k	–	> 1	–		$f = 20\text{ MHz} \dots 10\text{ GHz}$

1) Based on the application described in chapter 3

2) PCB losses are subtracted

3) To be within 1 dB of the final gain OFF- to ON-mode; to be within 3 dB of the final gain ON- to OFF-mode

4) Input Power = -30 dBm for each tone

5) Input Power = -20 dBm for each tone

3 Application Information

Application Board Configuration

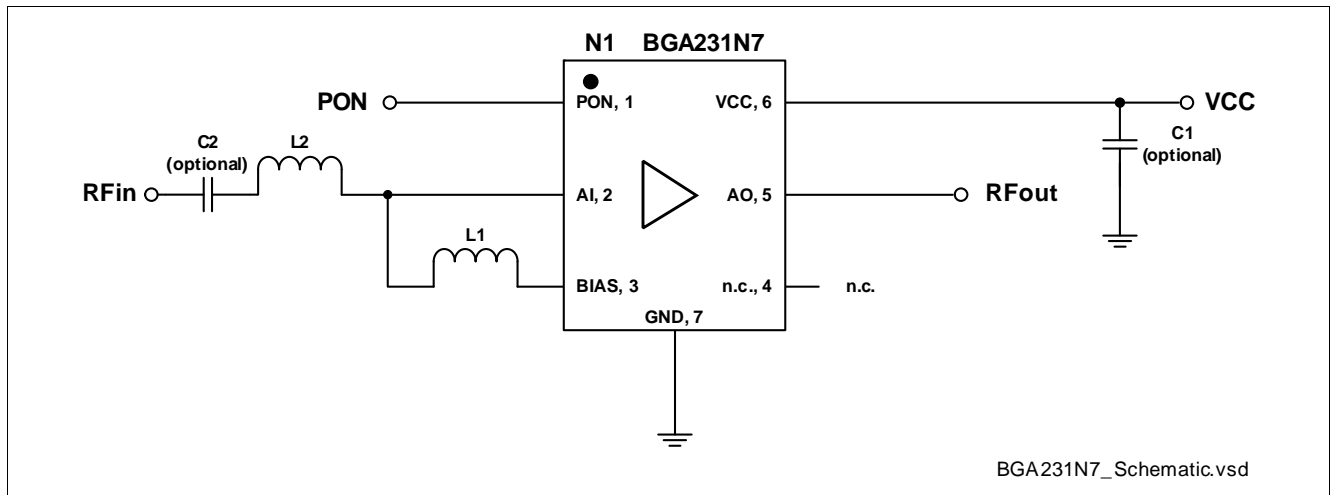

Figure 2 Application Schematic BGA231N7

Table 6 Bill of Materials

Name	Value	Package	Manufacturer	Function
C1 (optional)	100 nF	0201	Various	RF block ¹⁾
C2 (optional)	33 pF	0201	Various	DC block ²⁾
L1	39 nH	0201	Murata LQP03T	Bias feed and RF choke
L2	6.8 nH	0201	Murata LQP03T	Input matching
N1	BGA231N7	TSNP-7-1 / TSNP-7-2	Infineon	SiGe LNA

1) RF bypass recommended to mitigate power supply noise

2) DC block might be realized with pre-filter in GNSS applications

A list of all application notes is available at <http://www.infineon.com/gpslna.appnotes>.

4 Package Information

4.1 TSNP-7-1

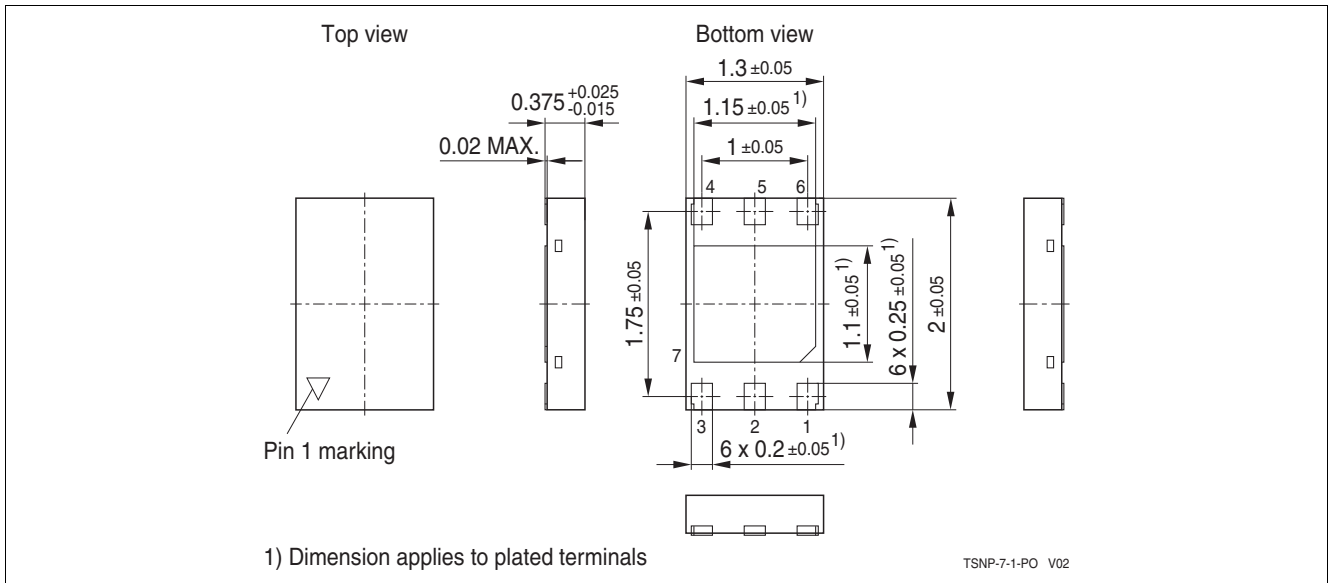

Figure 3 Package Dimensions for TSNP-7-1

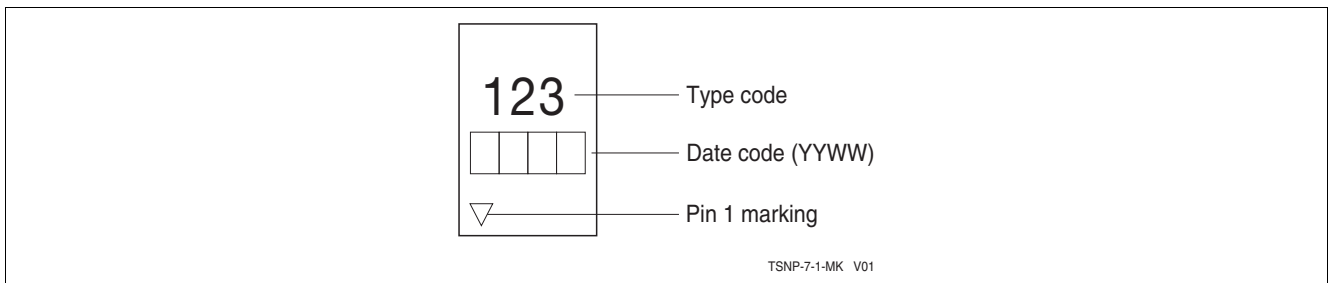

Figure 4 Marking Layout TSNP-7-1 (top view)

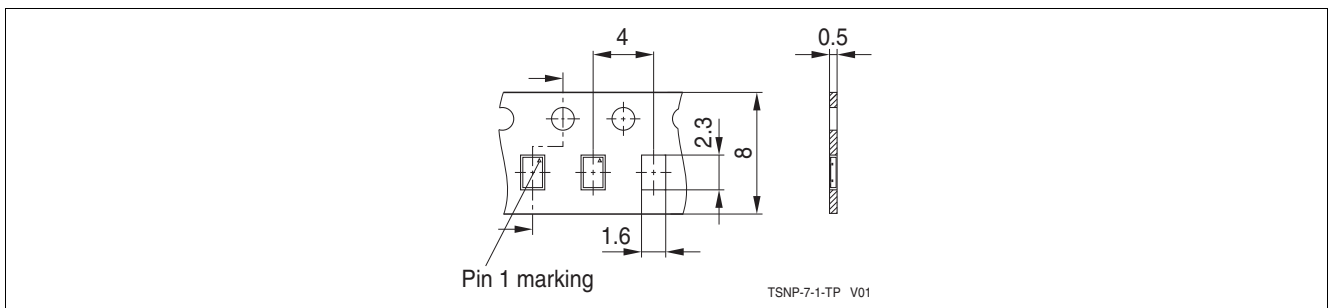

Figure 5 Tape & Reel Dimensions TSNP-7-1 (Ø reel 180, pieces/reel 7500)

4.2 TSNP-7-2

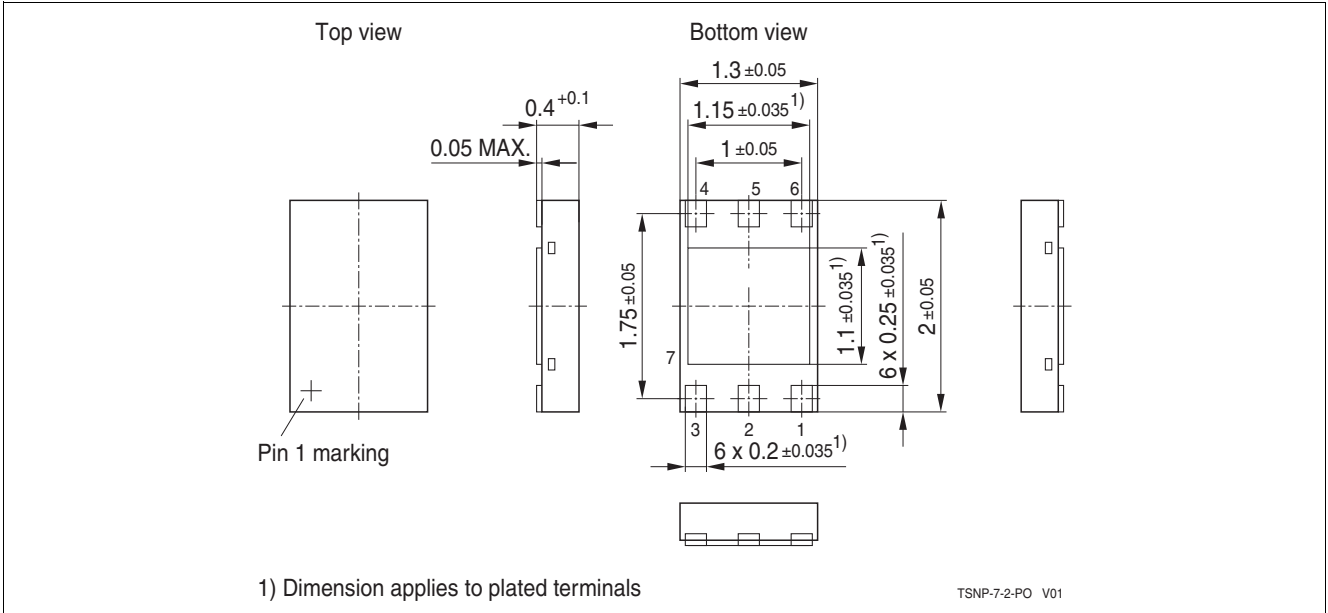

Figure 6 Package Dimensions for TSNP-7-2

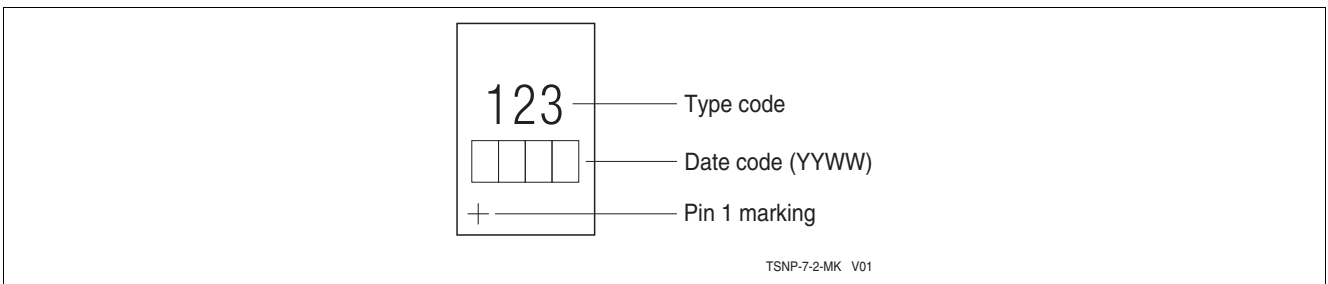

Figure 7 Marking Layout TSNP-7-2 (top view)

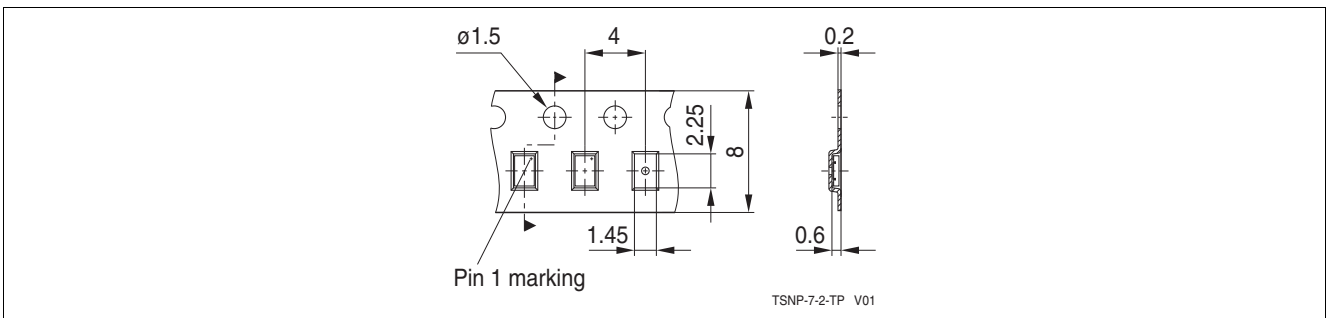

Figure 8 Tape & Reel Dimensions TSNP-7-2 (Ø reel 180, pieces/reel 6000)

4.3 Footprint Recommendation

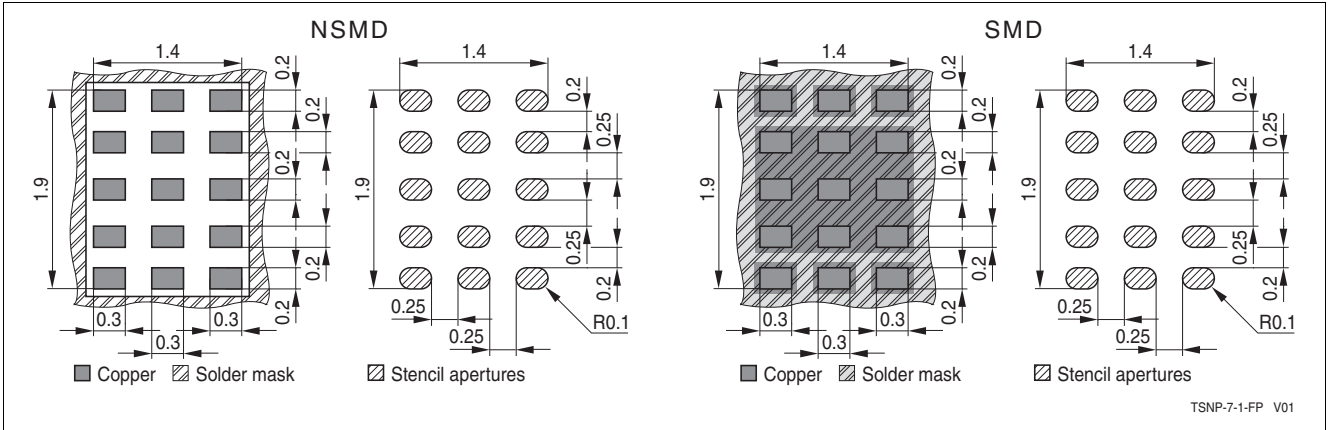

Figure 9 Footprint Recommendation 1 for TSNP-7-1 / TSNP-7-2

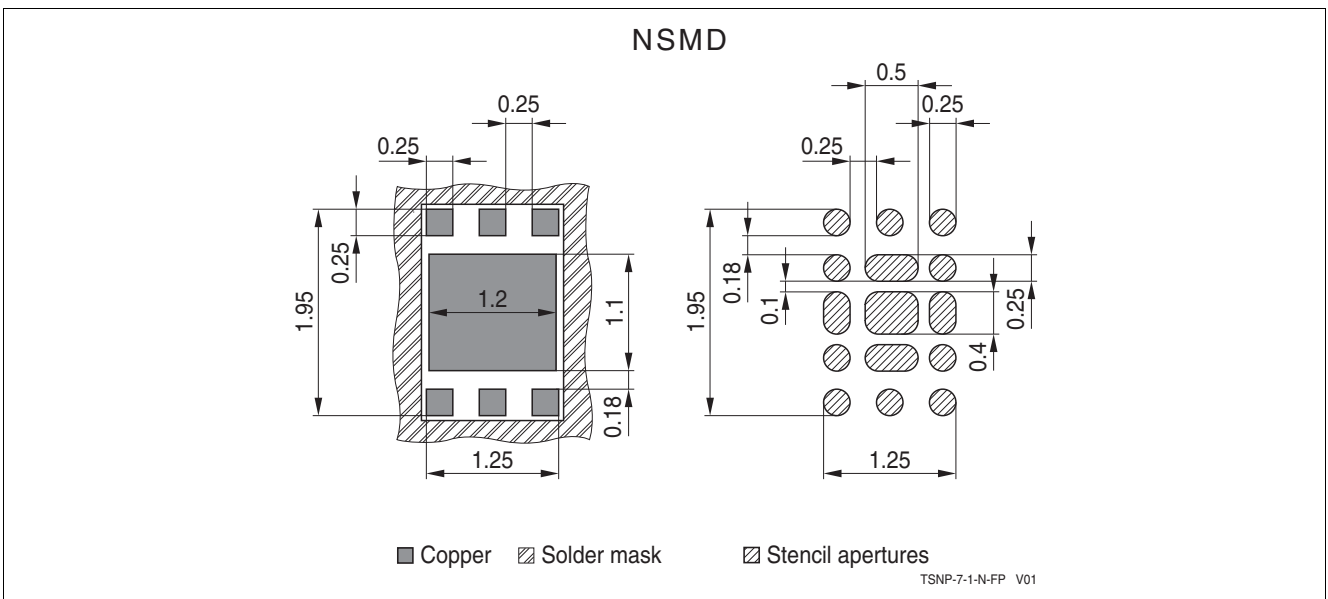

Figure 10 Footprint Recommendation 2 for TSNP-7-1 / TSNP-7-2

www.infineon.com

Published by Infineon Technologies AG