

## NPN General Purpose Amplifier

## BCW60

### FEATURES

- Low current(max.100mA).
- Low voltage (max.32V) .



### APPLICATIONS

- General purpose medium power amplifier.
- Switching application.

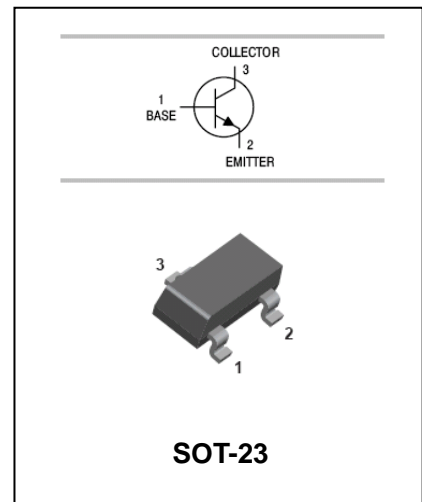

### ORDERING INFORMATION

Type No.	Marking	Package Code
BCW60B/C/D	AB/AC/AD	SOT-23

### MAXIMUM RATING @ Ta=25°C unless otherwise specified

Symbol	Parameter	Value	Unit
V <sub>CBO</sub>	Collector-Base Voltage	32	V
V <sub>CEO</sub>	Collector-Emitter Voltage	32	V
V <sub>EBO</sub>	Emitter-Base Voltage	5	V
I <sub>C</sub>	Collector Current -Continuous	100	mA
P <sub>C</sub>	Collector Dissipation	250	mW
T <sub>j</sub> , T <sub>stg</sub>	Junction and Storage Temperature	-65to+150	°C

## NPN General Purpose Amplifier

## BCW60

### ELECTRICAL CHARACTERISTICS @ Ta=25°C unless otherwise specified

Parameter	Symbol	Test conditions	MIN	MAX	UNIT
Collector-base breakdown voltage	$V_{(BR)CBO}$	$I_C=10\mu A I_E=0$	32		V
Collector-emitter breakdown voltage	$V_{(BR)CEO}$	$I_C=10mA I_B=0$	32		V
Emitter-base breakdown voltage	$V_{(BR)EBO}$	$I_E=1\mu A I_C=0$	5		V
Collector cut-off current	$I_{CBO}$	$V_{CB}=32V I_E=0$		20	nA
Emitter cut-off current	$I_{EBO}$	$V_{EB}=4V I_C=0$		20	nA
DC current gain	BCW60B	$V_{CE}=5V I_C=2mA$	180	310	
	BCW60C		250	460	
	BCW60D		380	630	
Collector-emitter saturation voltage	$V_{CE(sat)}$	$I_C=10mA I_B=0.25mA$ $I_C=50mA I_B=1.25mA$		0.35 0.55	V
Base-emitter saturation voltage	$V_{BE(sat)}$	$I_C=10mA I_B=0.25mA$ $I_C=50mA I_B=1.25mA$		0.85 1.05	V
Transition frequency	$f_T$	$V_{CE}=5V I_C=10mA$ $f=100MHz$	100	250	MHz

### TYPICAL CHARACTERISTICS @ Ta=25°C unless otherwise specified

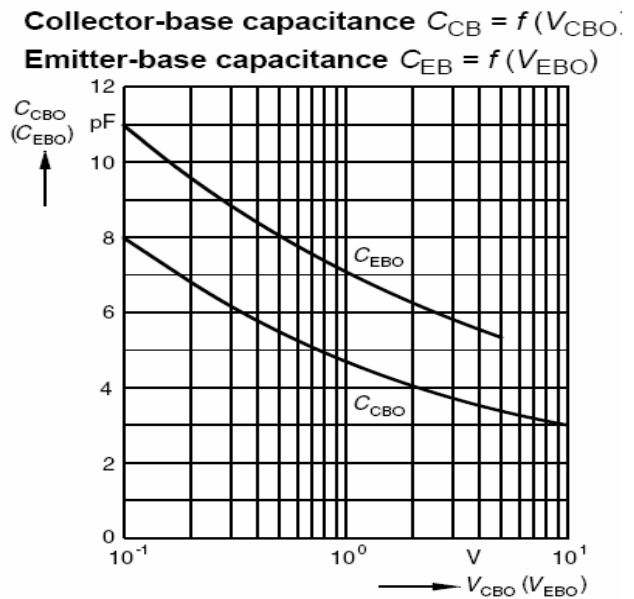
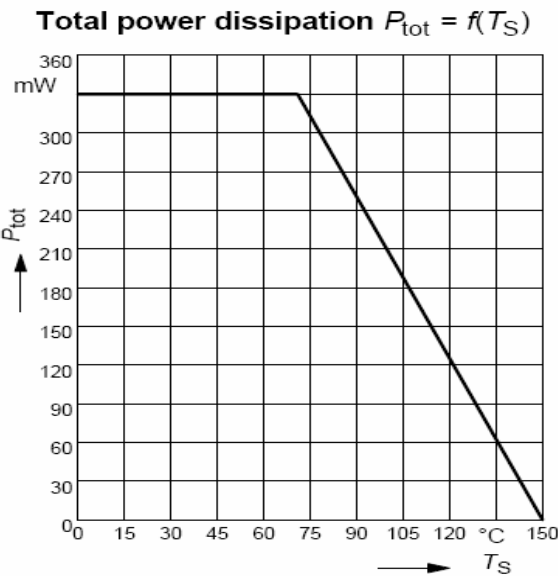

## NPN General Purpose Amplifier

## BCW60

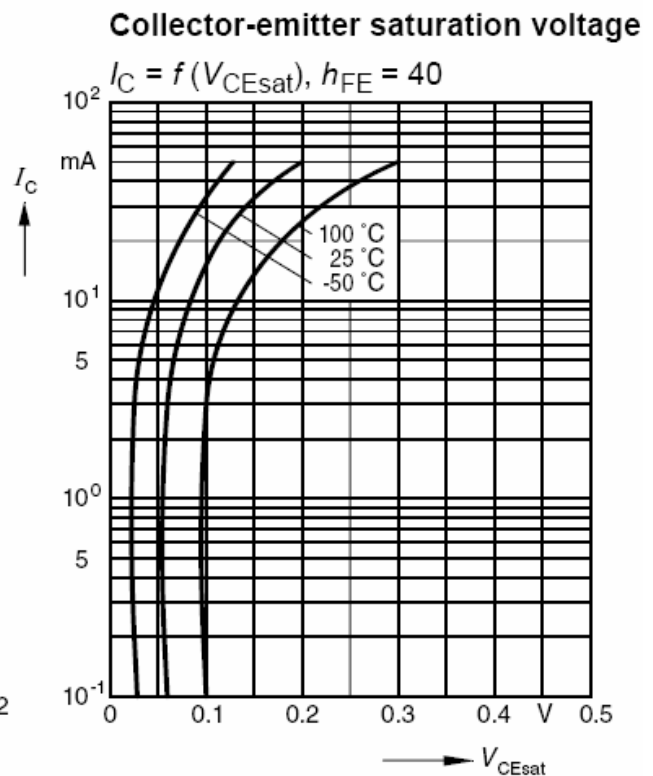
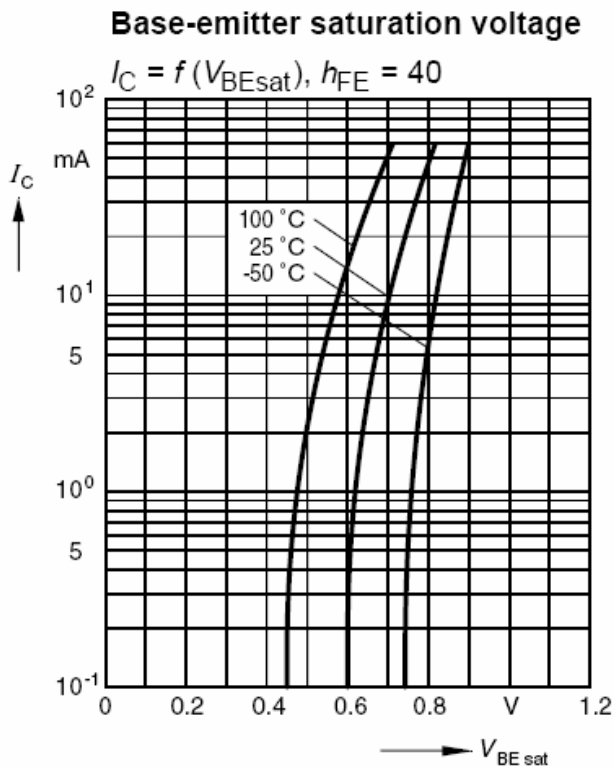
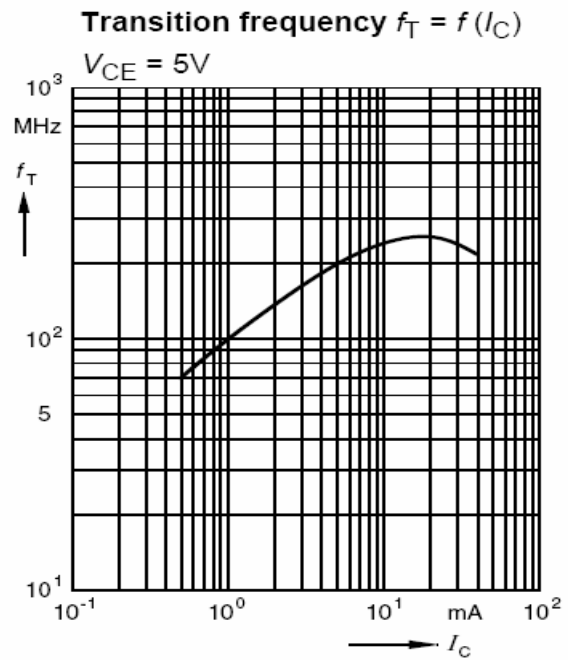
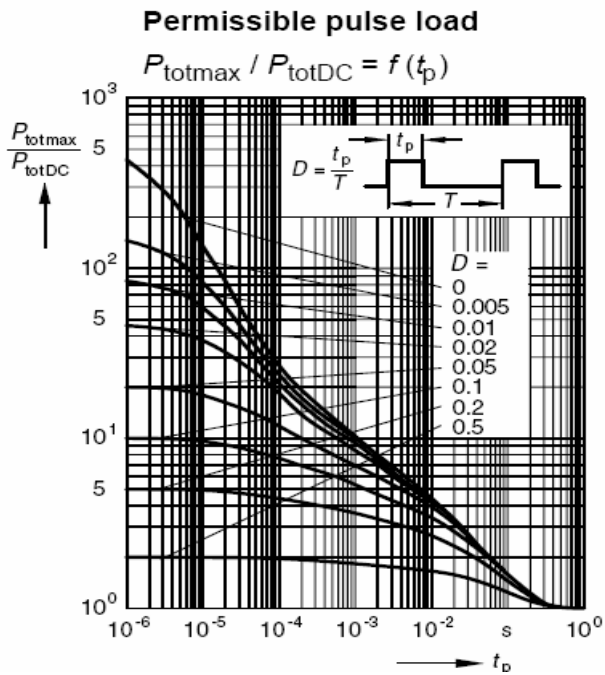

## NPN General Purpose Amplifier

## BCW60

### PACKAGE OUTLINE

Plastic surface mounted package

SOT-23

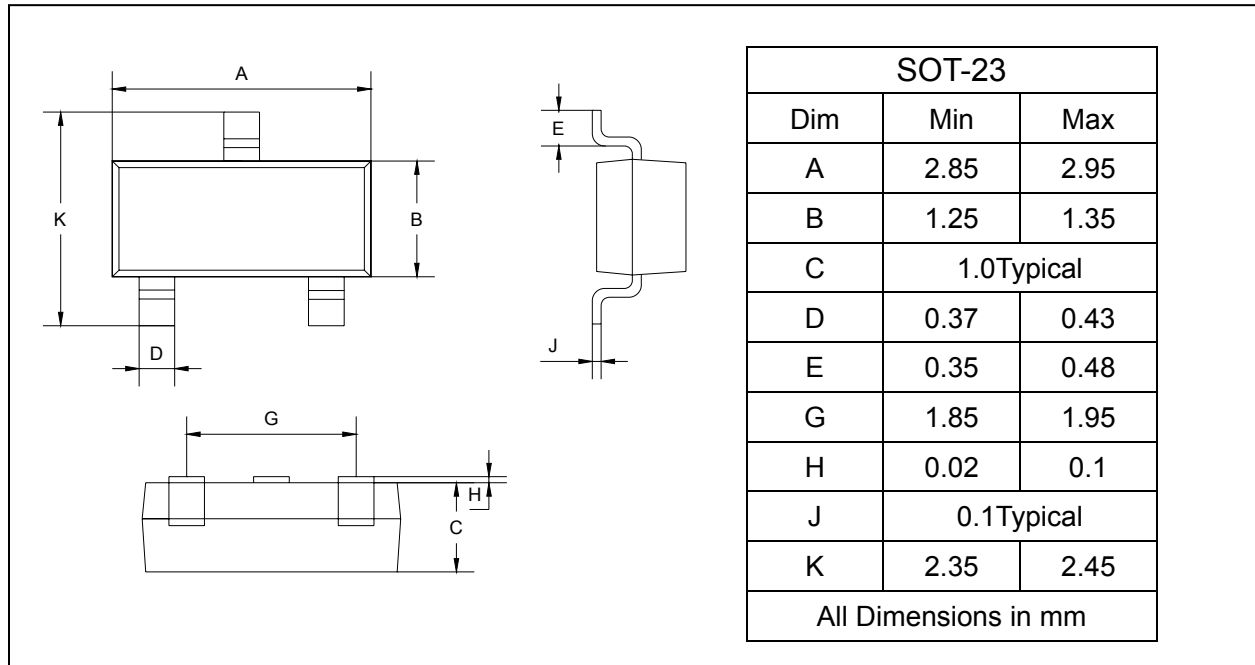

### SOLDERING FOOTPRINT

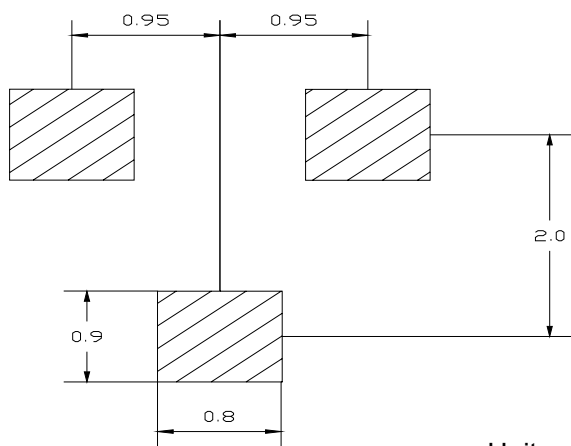

Unit: mm

### PACKAGE INFORMATION

Device	Package	Shipping
BCW60	SOT-23	3000/Tape&Reel