



## QUAD-PORT GIGABIT ETHERNET COPPER TRANSCEIVER WITH COPPER/ FIBER MEDIA INTERFACE

### FEATURES

- Four fully-integrated 10BASE-T/100BASE-TX/1000BASE-T Gigabit Ethernet transceivers
- RGMII, SGMII, and SerDes MAC interface options
- Copper or SerDes line interface options
- Fully compliant with IEEE 802.3, IEEE 802.3u, and IEEE 802.3ab standards
- 0.13-micron CMOS for low power consumption and low cost
- Low power
  - 750 mW per port
  - Advanced power management
- Trace matched output impedance
- Line-side loopback
- Ethernet@Wirespeed™ support
- Low EMI emissions
- CableChecker™ diagnostics
  - CableChecker software detects cable plant impairments.
  - Link quality indication LED.
  - Automatic detection and correction of wiring pair swaps, pair skew, and pair polarity.
  - Automatic MDI/MDIX crossover at all speeds
- Robust cable-sourced electrostatic discharge (CESD) tolerance
- Support for jumbo packets up to 10 kB
- IEEE 1149.1 (JTAG) boundary scan
- 256-pin BGA package

### SUMMARY OF BENEFITS

- Low-power quad-port integration enables single-row, high-port-density switches.
  - Lowers system costs by eliminating PCB layers required for routing high-density solutions.
  - Reduces I/O pin requirements with RGMII (over 50%), SGMII (over 75%), and SerDes (over 80%).
  - Supports clock timing adjustment to eliminate board trace delays required by the RGMII specification.
  - Lowers MAC/switch costs by reducing the number of pins required to interface with the PHY.
- Flexibility for copper or fiber applications.
- Provides compatibility with IEEE standard devices operating at 10, 100, and 1000 Mbps at half-duplex and full-duplex.
- Eases system level debugging.
- Enables use of low-cost magnetics, even in high-density (48+ port) designs.
- Ethernet@Wirespeed controls auto-negotiation advertising to enable link establishment at lower speeds when a 1000BASE link fails to be established.
- CableChecker software characterizes cable plant condition and immediately indicates cabling issues.
  - Prevents erroneous equipment return due to bad cable plants.
  - Prevents manufacturing fallout due to bad cable plants.
- Over 3 kV of CESD tolerance prevents equipment damage and return.
- Operates with larger packets for wider range of packet protocol support and improved efficiency.
- Ease of manufacturing with JTAG support, simplified power supply, and multiple MAC interfaces.

**BCM5466SR System Diagram**

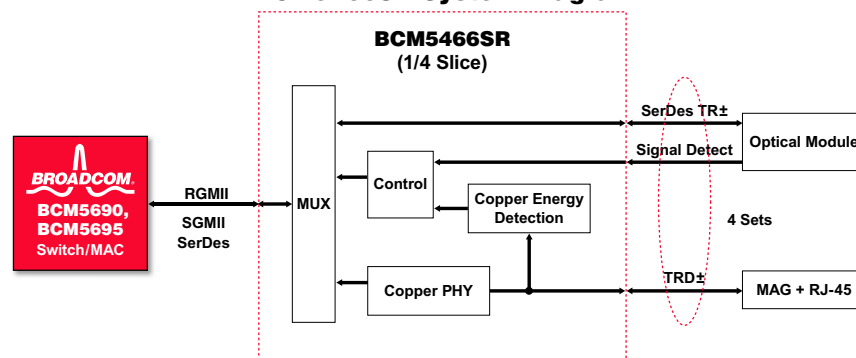

# OVERVIEW

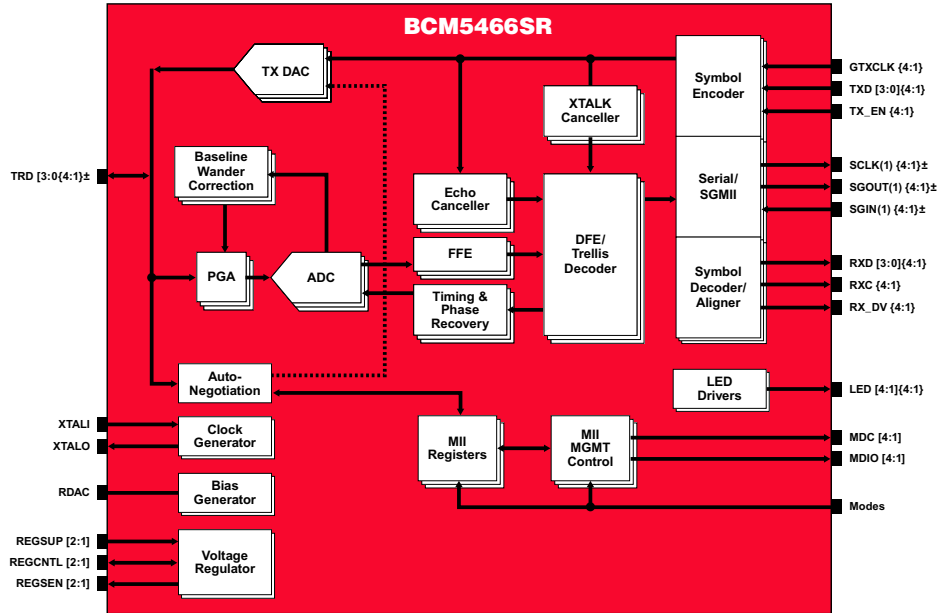

## BCM5466SR Reference Design

The BCM5466SR is a member of Broadcom's QuadSquad™ family of quad Gigabit Ethernet PHYs. It consists of four complete 10/100/1000BASE-T Gigabit Ethernet transceivers integrated on a single monolithic CMOS chip. The BCM5466SR is optimized for low power and small footprint size to enable high-port-density applications. The BCM5466SR enables a new class of cost-effective Gigabit Ethernet equipment by lowering system cost and reducing power dissipation by nearly 25%, driving the delivery of Gigabit Ethernet bandwidth to the desktop.

The BCM5466SR DSP-based architecture and advanced power management techniques combine to achieve robust and low power operation over existing Category 5 twisted-pair wiring. The BCM5466SR architecture not only meets the requirements of IEEE 802.3, IEEE 802.3u, and IEEE 802.3ab, but maintains the industry's highest level of margin over IEEE requirements for echo, near-end crosstalk (NEXT), and far-end crosstalk (FEXT). Low power is key to implementing high-density Gigabit switches, and the BCM5466SR has the lowest power in the industry at less than 750 mW per port. In addition, the BCM5466SR has extremely low EMI emissions, which reduces the design constraints required to meet EMI radiation specifications.

The BCM5466SR supports RGMII, SGMII, and SerDes MAC interfaces. A unique feature of the BCM5466SR is its ability to support both copper and fiber networks, with an integrated SerDes PHY interface that can connect directly to a fiber-optic module. Switching between copper and fiber media can be accomplished either automatically or through software

control. The BCM5466SR monitors copper link and fiber signal detect status, and automatically swaps either copper traffic or fiber traffic to the MAC/switch based on priorities set at initialization.

This device is another member of Broadcom's 0.13-µm Gigabit Ethernet copper PHY family, joining more than a dozen other quad and single products. The 0.13-µm process is the optimal process that offers the best performance, lowest cost, and lowest power for Gigabit Ethernet copper solutions. Devices based on the 0.13-µm process offer an excellent long-term cost curve, enabling better cost reduction over time (compared to older technologies) without having to redesign or requalify a new part.

Each port of the BCM5466SR is fully independent and has individual interface, control, and status registers, and incorporates a number of advanced features. A link-quality indicator LED gives installers an instant visual indication if there are any problems with the wiring plant supporting operation at the preferred speed. This includes physical wiring defects that the BCM5466SR cannot automatically correct for, and channel conditions such as excessive cable length and return loss, crosstalk, echo, and noise. Broadcom's CableChecker software provides remote management of the cable and first level diagnostics and fault isolation.

The BCM5466SR also has ESD tolerance well above typical industry standards. This prevents ESD damage not only during manufacturing, but also during CESD events in the field. The CESD is an ESD event that occurs when an electrically charged network cable is plugged into a network port, which is an issue becoming more prevalent with recent cable installations. The BCM5466 can tolerate over 3 kV of CESD.

Broadcom®, the pulse logo, Connecting everything®, and the Connecting everything logo are among the trademarks of Broadcom Corporation and/or its affiliates in the United States, certain other countries and/or the EU. Any other trademarks or trade names mentioned are the property of their respective owners.

Connecting  
everything®



**BROADCOM CORPORATION**  
16215 Alton Parkway, P.O. Box 57013  
Irvine, California 92619-7013

© 2006 by BROADCOM CORPORATION. All rights reserved.

5466SR-PB03-R 8/21/06

Phone: 949-450-8700  
Fax: 949-450-8710  
E-mail: info@broadcom.com  
Web: www.broadcom.com