



## OPTIMIZED 802.11G ROUTER WITH BROADRANGE™

### FEATURES

- **240-MHz MIPS32® CPU core**
  - 16-KB instruction cache, 16-KB data cache, and 1-KB pre-fetch cache
  - Memory Management Unit (MMU) for high-level Real-Time Operating System (RTOS) support
- **2.4-GHz direct conversion radio**
- **USB 2.0 host controller**
- **SDRAM controller**
  - 16-bit, 120-MHz SDRAM controller
  - SDR and DDR support
  - 2 MB to 128 MB capacity
- **Supports serial or parallel flash**
- **Five-port integrated 10/100BASE-TX/FX IEEE 802.3u compliant Auto-MDIX transceivers and LAN/WAN switch controller**
- **Eight GPIOs for attachment to various external devices (example: LEDs)**
- **One JTAG and two UART ports for debugging development and attaching Data Terminal Equipment (DTE)**
- **0.13 um technology**

### SUMMARY OF BENEFITS

- **The BCM5354 achieves the lowest cost and highest performance router system-on-chip (SoC) integration for residential and small office, home office (SOHO) markets**
- **Time-to-market is significantly reduced through stable Linux® and VxWorks® kernels, board support packages (BSPs), drivers and toolchains**
- **Turn-key software is code compatible with other AirForce™ routers and access points (APs) enabling seamless migration of proprietary features**
- **USB host interface allows for platform expansion by end users and can support USB print server or Microsoft Windows® Connect Now functionality**
- **Supports high-speed performance mode (HSM) of 125 Mbps that is backward-compatible with standard 802.11 b/g**
- **BroadRange™ signal processing technology enhances receive sensitivity resulting in excellent wireless throughput and range in a home and business environment**

### Low Cost 802.11g Router

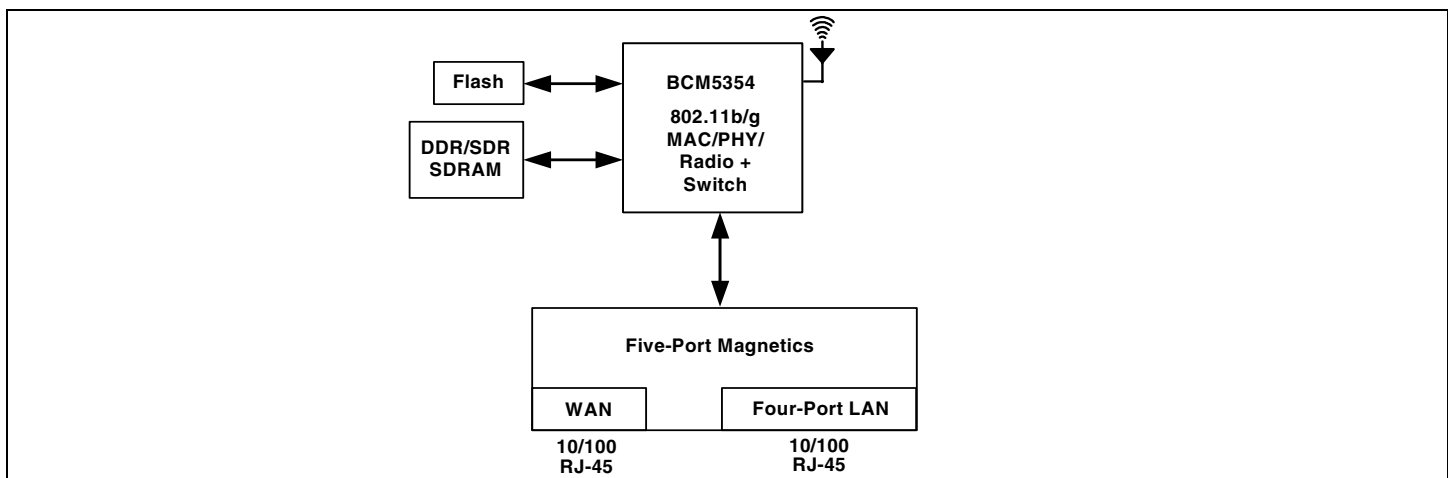

## OVERVIEW

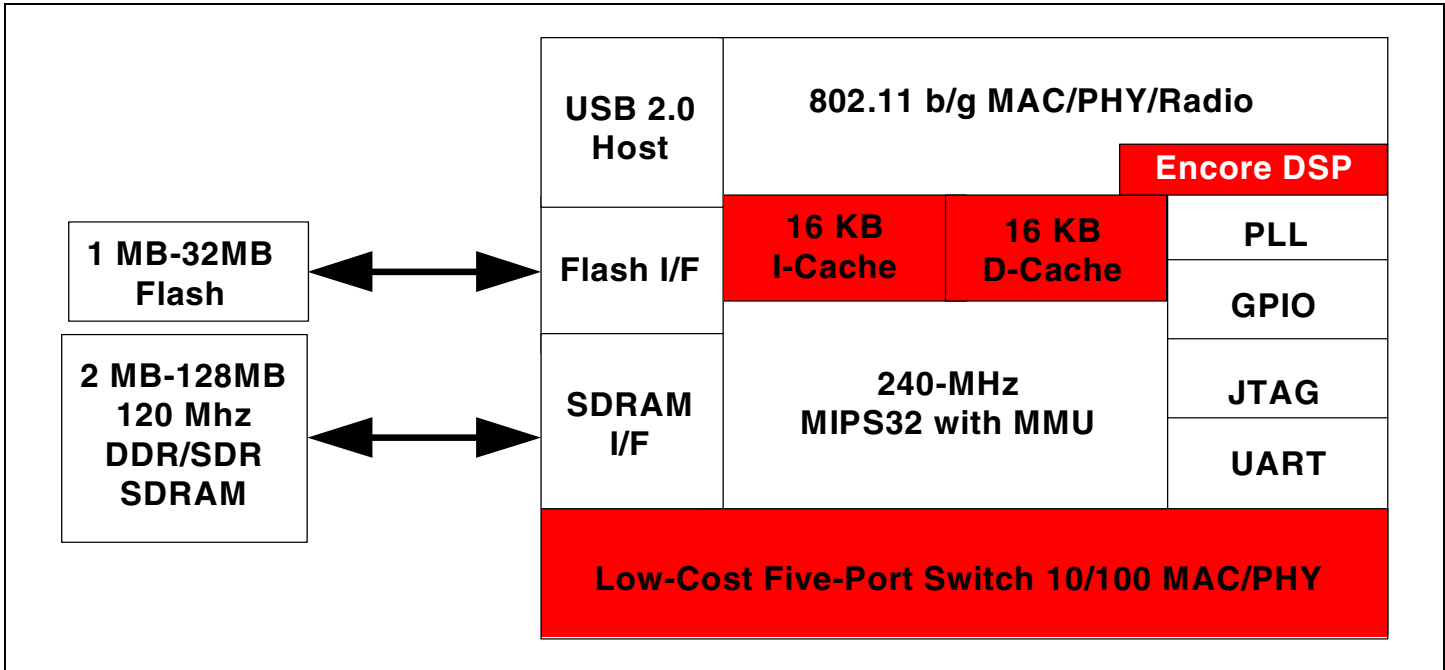

### System Block Diagram

The BCM5354 integrates a high-performance MIPS32 processor, IEEE 802.11 b/g MAC/PHY, 2.4-GHz direct conversion radio, USB 2.0 host controller, SDRAM controller, and a configurable five-port Fast Ethernet (FE) switch.

The BCM5354 provides wireless LAN connectivity that supports data rates of up to 125 Mbps that is backward-compatible with standard 802.11 b/g.

The BCM5354 supports a WAN connection via its configurable media interfaces. The per-port programmable four-level priority queues enable QoS (IEEE 802.1p) for guaranteed bandwidth applications, DiffServ/TOS, and L2/L3 IGMP snooping. The IEEE 802.1Q VLAN allows flexible implementation of VLAN grouping and WAN port segregation.

Applications running on the BCM5354 leverage field-proven software which includes SecureEasySetup™ and comprehensive wireless network security support that comprises WEP/WPA/WPA2 encryption.

The BCM5354 offers the industry's most aggressive home router integration and enables the lowest bill of materials (BOM) solution cost.

Broadcom's superior technology and innovation also benefit manufacturers with faster time-to-market, and end products that are differentiated from the competition through rich features, exceptional range, and outstanding reliability.

**Broadcom**®, the pulse logo, **Connecting everything**®, the Connecting everything logo, AirForce™, SecureEasySetup™, and BroadRange™, are among the trademarks of Broadcom Corporation and/or its affiliates in the United States, certain other countries and/or the EU. Any other trademarks or trade names mentioned are the property of their respective owners.

Connecting  
**everything**®



**BROADCOM CORPORATION**  
16215 Alton Parkway, P.O. Box 57013  
Irvine, California 92619-7013

© 2007 by BROADCOM CORPORATION. All rights reserved.

5354-PB00-R 01/24/07

Phone: 949-450-8700  
Fax: 949-926-5203  
E-mail: [info@broadcom.com](mailto:info@broadcom.com)  
Web: [www.broadcom.com](http://www.broadcom.com)