



## 10/100BASE-TX/FX HEX-Φ™ TRANSCEIVER

### FEATURES

- Single-chip six-port Fast Ethernet transceiver
- HP Auto-MDIX
- Low-power 2.5V CMOS technology
- Compatible with 2.5V I/O and 3.3V I/O
- Reduced Media Independent Interface (RMII)
- Serial Media Independent Interface (SMII)
- Fully integrated digital adaptive equalization
- On-chip multimode transmit waveshaping
- Edge-rate control eliminates external filters
- Integrated baseline wander correction
- Full-duplex support
- Twisted-pair or fiber support on any or all ports
- Interrupt output capability
- Loopback mode for diagnostics
- 160-pin PQFP (BCM5226R)
- 128-pin PQFP (BCM5226S)
- Proven Broadcom proprietary DSP Digi-Φ™ architecture

### SUMMARY OF BENEFITS

- Target usage: Fast Ethernet switches.
- Low power < 300 milliwatts per port.
- Auto-MDIX detects and corrects cabling errors.
- Provides robust performance over a broad range of operating conditions.
- Single-chip device contains six independent Fast Ethernet transceivers.
- Performs all physical layer interface functions for 100BASE-TX full-duplex or half-duplex Ethernet on Category 5 twisted-pair cable and 10BASE-T full- or half-duplex Ethernet on Category 3, 4, or 5 cable.
- Permits transmission over fiber-optic cabling when paired with an external fiber-optic transceiver.
- Compliant with IEEE 802.3 standard.
- IEEE 1149.1 (JTAG) scan chain support.

### Quad BCM5208 Versus HEX BCM5226 Comparison

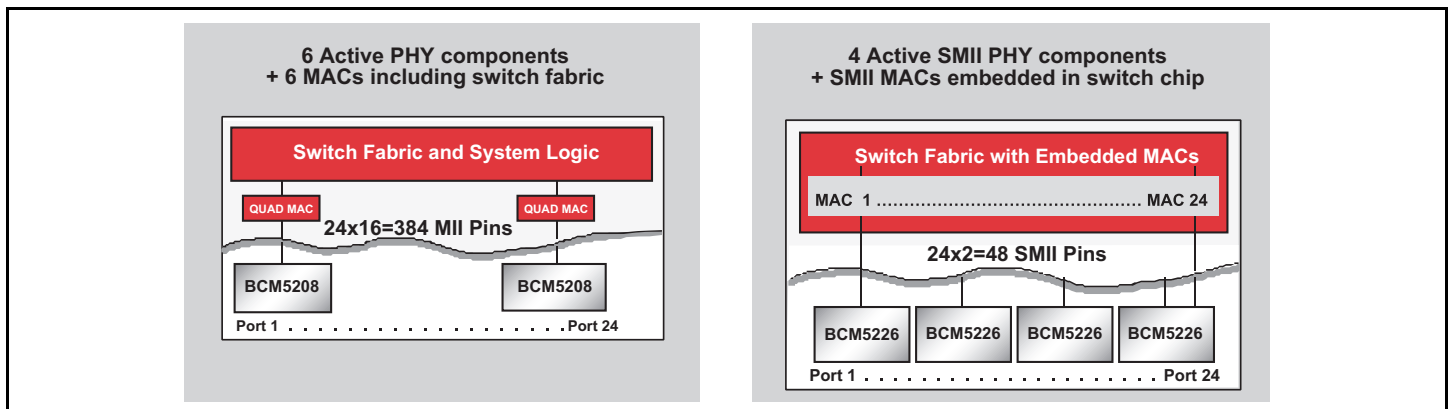

# OVERVIEW

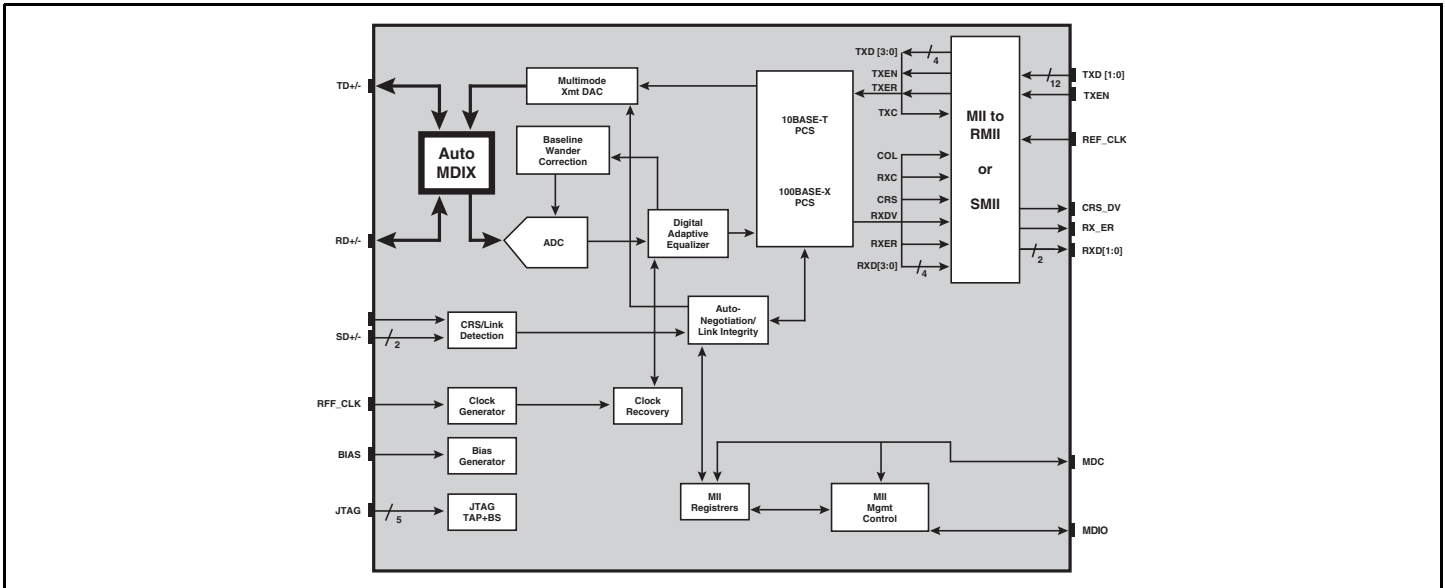

The Broadcom® BCM5226 is a single-chip device containing six independent Fast Ethernet transceivers. Each performs all the physical layer interface functions for 100BASE-TX full-duplex or half-duplex Ethernet on Category 5 twisted-pair cable and 10BASE-T full or half-duplex Ethernet on Category 3, 4 or 5 cable. Each port may also be configured for 100BASE-FX full or half-duplex transmission over fiber-optic cabling when paired with an external fiber-optic line transceiver.

The BCM5226 chip performs 4B5B, MLT3, NRZI, and Manchester encoding and decoding, clock and data recovery, stream cipher scrambling/descrambling, digital adaptive equalization, line transmission, carrier sense and link integrity monitoring, auto-negotiation and RMII management functions.

The BCM5226 can be connected to a switch controller through the RMII on one side and connects directly to the network media on the other side through isolation transformers for UTP modes or fiber-optic transceiver components for FX mode. The BCM5226 is compliant with the IEEE 802.3 standard.

The BCM5226 operates from a 2.5V power supply, which dramatically lowers total power consumption compared to 3.3V and 5V designs. The BCM5226 I/O operates at either 2.5V or 3.3V, for compatibility with 3.3V designs.

The BCM5226 is the first 10/100 Ethernet transceiver to incorporate the Hewlett-Packard auto-Media Dependent Interface Crossover (Auto-MDIX) feature. Originally specified in the IEEE 802.3ab Gigabit Ethernet standard for Category 5 cable, the Auto-MDIX feature enables the transceiver to automatically detect and correct a crossed cable. This allows system installation and maintenance personnel to use crossover or straight-through cables interchangeably, regardless of whether the cable is attached to another switch, network interface card or repeater. This capability eliminates incorrect connections due to cable mismatch, making it easier and less expensive to install and operate 10/100 Ethernet switches.

The BCM5226R supports RMII, and is available in a 160-pin plastic quad flatpack package (PQFP); the BCM5226R supports SMII, and is available in a 128-pin PQFP.

Broadcom®, the pulse logo, and Connecting everything® are trademarks of Broadcom Corporation and/or its subsidiaries in the United States and certain other countries. All other trademarks mentioned are the property of their respective owners.

Connecting  
everything®



**BROADCOM CORPORATION**  
16215 Alton Parkway, P.O. Box 57013  
Irvine, California 92619-7013

© 2004 by BROADCOM CORPORATION. All rights reserved.

5226-PB06-R 04/07/04

Phone: 949-450-8700  
Fax: 949-450-8710  
E-mail: info@broadcom.com  
Web: www.broadcom.com