



## 802.11ac/n/a single band 3x3 PCIe mini card, BCM4360 **ac 3x3**

### Model: DAXB-81



DAXB-81 is a 3x3 802.11ac/n/a wifi module in PCIe mini card form factor designed to deliver up to 1.3Gbps PHY rates, targeted to provide the increased coverage and throughput performance requirement for high quality video and media applications in the home and enterprise.

A new, highly efficient architecture reduces processing requirements and power consumption, while nearly tripling wireless performance of 802.11n 3x3. DAXB-81 enables access points, routers, PC notebook computers, and digital TV/media devices to offer greater than gigabit speeds over Wi-Fi networks.

### Key Features:

- 1.3Gbps PHY rate performance offering over 3 times performance of 802.11n 3x3.
- Supports 20/40/80MHz bandwidth and 256 QAM to maximize data transfer efficiency.
- 802.11ac-compliant transmit and receive Beamforming for extended coverage of 802.11ac and legacy devices.
- Compact size 29.85 x 50. 8 mm PCIe mini card form factor with screw mounting hole to firmly embed onto main board.
- Three U.FL antenna connectors enable design flexibility to utilize different transmit/receive chains to communicate with different users.
- RoHS compliance ensure a high level protection of human health and the environment from risks that can be posed by chemicals.

Outline

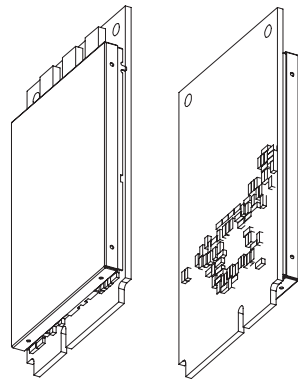
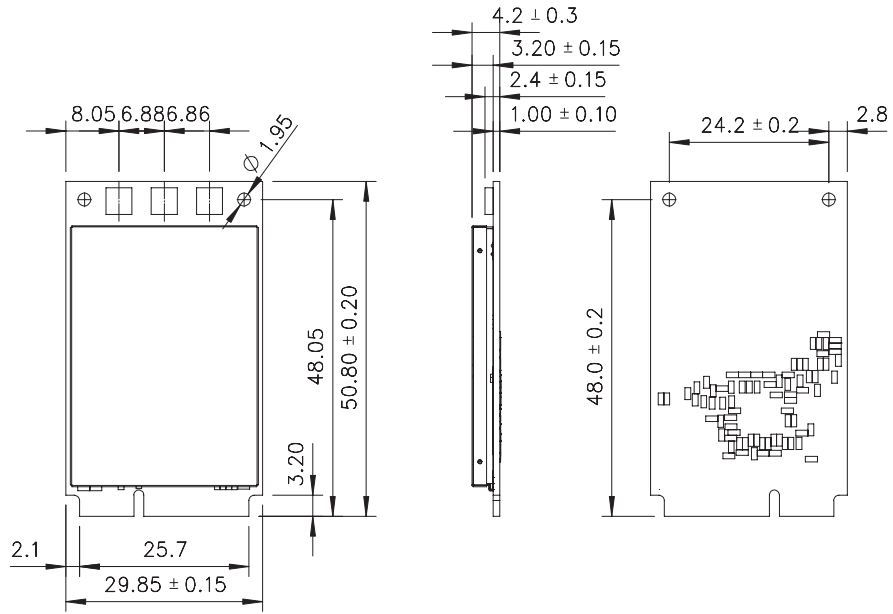

ISOMETRIC

REFERENCE ONLY  
SCALE 1:1

Block Diagram

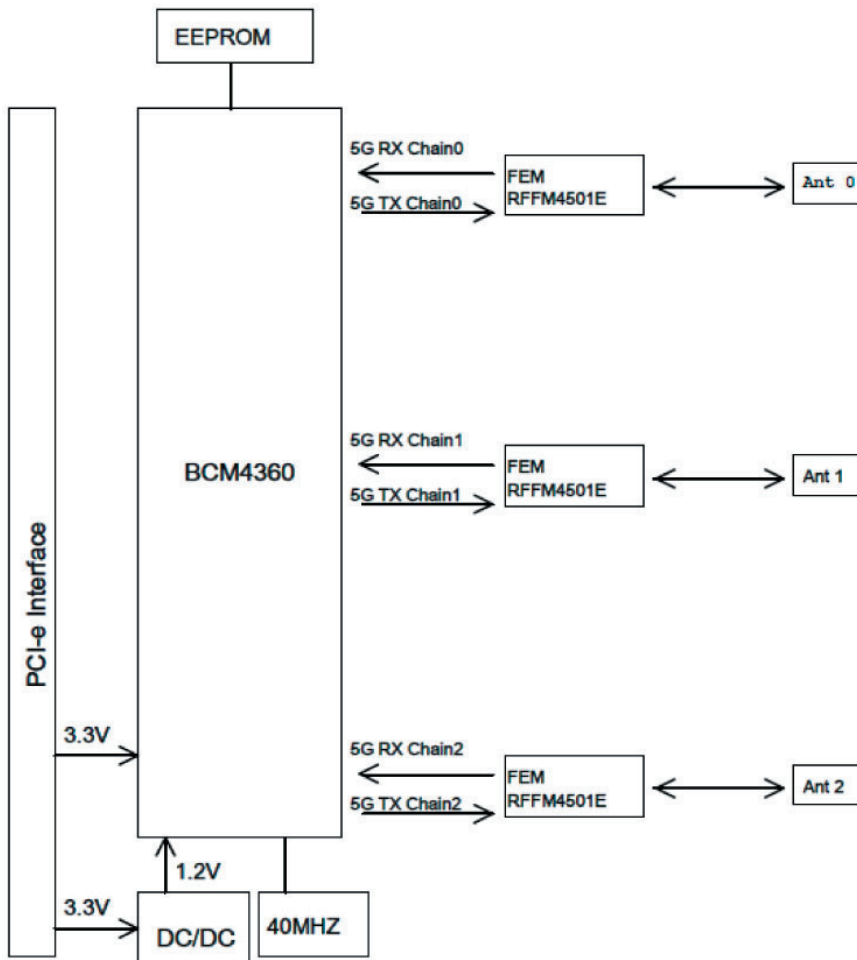

Pin Assignment:			
Pin No.	Name	Direction	Description
4,9,15,18,21,26,27,29,34,35,37,40,43,50	GND	---	Ground.
45	RESERVED	---	No connection.
47	RESERVED	I/O	Reserved for GPIO5 of BCM4360
49,51	RESERVED	I/O	No connection.
3	RESERVED		COEX1
5	RESERVED	I/O	COEX2
8,10,12,14,16,17,19,	NC	---	No connection.
33	PETP0	Analog input signal	Differential receiver
31	PETN0	Analog input signal	Differential receiver
25	PERP0	Analog output signal	Differential trnasmit
23	PERN0	Analog output signal	Differential trnasmit
13	REFCLK+	Analog input signal	Differential reference clock .
11	REFCLK-	Analog input signal	Differential reference clock .
20	RF_DISABLE_L	I/O	RF DISABLE
7	PCIE_CLKREQ_L	A digital output signal with open drain	PCIe clock request signal indicates that refclk to the PCIe interface can be gated.
22	PCIE_PERST_L	PCI Express reset . This input is the PCIe reset as defined in the PCIe base specification version 1.1.	
1	PCIE_WAKE_EL	A digital output signal with open drain	PCIE_PME_L
32	SMB_DATA	---	No connection.
30	SMB_CLK	---	No connection.
46	LED_WPAN_L	---	No connection.
44	LED_WLAN+	O	GPIO1
42	LED_WWAN+	---	No connection.
38	USB_DP	I/O	USB_P
36	USB_DN	I/O	USB_N
6,28,48	1.5V	---	No connection.
2,24,39,41,52	3.3V	---	3.3V

<b>Specifications:</b>																													
<b>Main Chipset</b>	BCM4360																												
<b>Tx/Rx</b>	3T3R																												
<b>Standard Conformance</b>	802.11ac, 802.11na, and 802.11a																												
<b>Frequency Range</b>	<ul style="list-style-type: none"> <li>▪ USA: 5.15 – 5.35GHz, 5.47 – 5.725GHz, 5.725 – 5.825GHz</li> <li>▪ Europe: 5.15 – 5.35GHz, 5.47– 5.725GHz</li> <li>▪ Japan: 5.15– 5.35GHz, 5.47 – 5.725GHz</li> <li>▪ China: 5.725 – 5.85GHz</li> </ul>																												
<b>Interface</b>	PCI Express ® mini-card rev. 2.0																												
<b>Operating Channels</b>	<ul style="list-style-type: none"> <li>▪ USA/Canada: 12 non-overlapping channels</li> <li>▪ Major Europe Countries: 19 non-overlapping channels</li> <li>▪ Japan: 19 non-overlapping channels</li> <li>▪ China: 5 non-overlapping channels</li> </ul>																												
<b>Operation Voltage</b>	3.3V ± 5%																												
<b>Power Consumption (typical level, with ± 50mA tolerance)</b>	<table style="width: 100%; border-collapse: collapse;"> <thead> <tr> <th style="width: 80%;"></th> <th style="text-align: right; vertical-align: bottom;">Avg./Max. (mA)</th> </tr> </thead> <tbody> <tr> <td>11a continue Tx @ 6M, 17dBm</td> <td style="text-align: right;">920</td> </tr> <tr> <td>11na continue Tx @ HT20 MCS16 MIMO 17dBm</td> <td style="text-align: right;">915</td> </tr> <tr> <td>11na continue Tx @ HT40 MCS16 MIMO 17dBm</td> <td style="text-align: right;">930</td> </tr> <tr> <td>11na continue Tx @ HT20 MCS23 MIMO 14dBm</td> <td style="text-align: right;">830</td> </tr> <tr> <td>11na continue Tx @ HT40 MCS23 MIMO 14dBm</td> <td style="text-align: right;">850</td> </tr> <tr> <td>11ac continue Tx @ VHT40 MCS0 NSS3 17dBm</td> <td style="text-align: right;">930</td> </tr> <tr> <td>11ac continue Tx @ VHT80 MCS0 NSS3 17dBm</td> <td style="text-align: right;">945</td> </tr> <tr> <td>11ac continue Tx @ VHT40 MCS9 NSS3 14dBm</td> <td style="text-align: right;">830</td> </tr> <tr> <td>11ac continue Tx @ VHT80 MCS9 NSS3 14dBm</td> <td style="text-align: right;">900</td> </tr> <tr> <td>11a continue Rx</td> <td style="text-align: right;">370</td> </tr> <tr> <td>11ac continue Rx</td> <td style="text-align: right;">480</td> </tr> <tr> <td>Idle</td> <td style="text-align: right;">82</td> </tr> <tr> <td>Standby</td> <td style="text-align: right;">110</td> </tr> </tbody> </table>		Avg./Max. (mA)	11a continue Tx @ 6M, 17dBm	920	11na continue Tx @ HT20 MCS16 MIMO 17dBm	915	11na continue Tx @ HT40 MCS16 MIMO 17dBm	930	11na continue Tx @ HT20 MCS23 MIMO 14dBm	830	11na continue Tx @ HT40 MCS23 MIMO 14dBm	850	11ac continue Tx @ VHT40 MCS0 NSS3 17dBm	930	11ac continue Tx @ VHT80 MCS0 NSS3 17dBm	945	11ac continue Tx @ VHT40 MCS9 NSS3 14dBm	830	11ac continue Tx @ VHT80 MCS9 NSS3 14dBm	900	11a continue Rx	370	11ac continue Rx	480	Idle	82	Standby	110
	Avg./Max. (mA)																												
11a continue Tx @ 6M, 17dBm	920																												
11na continue Tx @ HT20 MCS16 MIMO 17dBm	915																												
11na continue Tx @ HT40 MCS16 MIMO 17dBm	930																												
11na continue Tx @ HT20 MCS23 MIMO 14dBm	830																												
11na continue Tx @ HT40 MCS23 MIMO 14dBm	850																												
11ac continue Tx @ VHT40 MCS0 NSS3 17dBm	930																												
11ac continue Tx @ VHT80 MCS0 NSS3 17dBm	945																												
11ac continue Tx @ VHT40 MCS9 NSS3 14dBm	830																												
11ac continue Tx @ VHT80 MCS9 NSS3 14dBm	900																												
11a continue Rx	370																												
11ac continue Rx	480																												
Idle	82																												
Standby	110																												

**Specifications:**

**Average Tx Power (typical power level per chain, with  $\pm 2$ dB tolerance)**

**IEEE 802.11 a/ac**

		CH36 ~ 48	CH52 ~ 64	CH100 ~ 165	
20MHz BW	6Mbps	17	17	17	
	9Mbps	17	17	17	
	12Mbps	17	17	17	
	18Mbps	17	17	17	
	24Mbps	17	17	17	
	36Mbps	17	17	17	
	48Mbps	17	17	17	
	54Mbps	17	17	17	
	HT20MCS0	17	17	17	
	HT20MCS1	17	17	17	
	HT20MCS2	17	17	17	
	HT20MCS3	17	17	17	
	HT20MCS4	17	17	17	
	HT20MCS5	17	17	17	
	HT20MCS6	17	17	17	
	HT20MCS7	15	15	15	
	VHT20_MCS8	14	14	14	
	40MHz BW	HT40MCS0	17	17	17
		HT40MCS1	17	17	17
HT40MCS2		17	17	17	
HT40MCS3		17	17	17	
HT40MCS4		17	17	17	
HT40MCS5		17	17	17	
HT40MCS6		17	17	17	
HT40MCS7		15	15	15	
VHT40_MCS8		14	14	14	
VHT40_MCS9		14	14	14	
80MHz BW	VHT80_MCS0	17	17	17	
	VHT80_MCS1	17	17	17	
	VHT80_MCS2	17	17	17	
	VHT80_MCS3	17	17	17	
	VHT80_MCS4	17	17	17	
	VHT80_MCS5	17	17	17	
	VHT80_MCS6	17	17	17	
	VHT80_MCS7	15	15	15	
	VHT80_MCS8	14	14	14	
	VHT80_MCS9	14	14	14	

## Specifications:

Receiver Sensitivity (typical sensitivity level per chain, with +/-2dB tolerance)	IEEE 802.11 a/ac			
		CH36 ~ 48	CH52 ~ 64	CH100 ~ 165
	20MHz BW	6Mbps	-95	-95
	9Mbps	-93	-93	-93
	12Mbps	-91	-91	-91
	18Mbps	-89	-89	-89
	24Mbps	-86	-86	-86
	36Mbps	-84	-83	-83
	48Mbps	-78	-78	-78
	54Mbps	-77	-77	-76
	HT20MCS0	-94	-94	-94
	HT20MCS1	-90	-90	-90
	HT20MCS2	-88	-88	-88
	HT20MCS3	-84	-84	-84
	HT20MCS4	-81	-81	-81
	HT20MCS5	-76	-76	-76
	HT20MCS6	-75	-75	-75
	HT20MCS7	-73	-73	-73
	VHT20_MCS8	-68	-68	-68
40MHz BW	HT40MCS0	-91	-91	-91
	HT40MCS1	-86	-86	-86
	HT40MCS2	-84	-84	-84
	HT40MCS3	-80	-80	-80
	HT40MCS4	-78	-78	-78
	HT40MCS5	-73	-73	-73
	HT40MCS6	-72	-72	-72
	HT40MCS7	-71	-71	-71
	VHT40_MCS8	-66	-66	-66
	VHT40_MCS9	-64	-64	-64
80MHz BW	VHT80_MCS0	-88	-88	-88
	VHT80_MCS1	-86	-86	-86
	VHT80_MCS2	-84	-84	-84
	VHT80_MCS3	-81	-81	-81
	VHT80_MCS4	-77	-77	-77
	VHT80_MCS5	-73	-73	-73
	VHT80_MCS6	-71	-71	-71
	VHT80_MCS7	-68	-68	-68
	VHT80_MCS8	-64	-64	-64
	VHT80_MCS9	-62	-62	-62
<b>Dimension</b>	29.85(W) x 50.8(L) mm			
<b>Operation Temperature Range</b>	0°C ~ +60°C			
<b>Storage Temperature Range</b>	-20°C ~ +80°C			
<b>Operating Humidity</b>	15% ~ 95%, non-condensing			
<b>Storage Humidity</b>	max. 95%, non-condensing			
<b>Human Health &amp; Environment-Friendly Compliance</b>	REACH and RoHS			

**Specifications:**

<b>Antenna Connector</b>	three U.FL ultra-miniature coaxial antenna connectors
--------------------------	---

**Ordering Information:**

<b>DAXB-81</b>	802.11ac/n/a single band 3x3 PCIe mini card, BCM4360
----------------	--



**Unex Technology Corp.**  
- Durable Bridge to Wireless

Sales-a@unex.com.tw  
<http://www.unex.com.tw>