

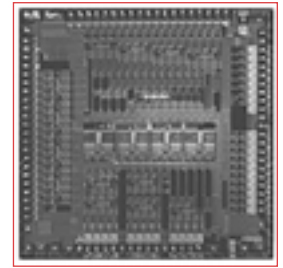

BCM3352 PRODUCT Brief



QAMLINK™ SINGLE-CHIP 4-CHANNEL VoIP BROADBAND GATEWAY IC

BCM3352 FEATURES

- The BCM3352 is the world's most highly integrated, lowest-cost and lowest-power, single-chip solution for cable residential gateway's providing four-channels of VoIP/FoIP and 32 Mbps home phone line networking.
- The BCM3352 Integrates:
 - Enhanced VoIP DOCSIS/EuroDOCSIS 1.1/1.0 MAC with 16 upstream queues
 - Payload header suppression (PHS) engine
 - 120 Dhrystone 2.1 MIPS32 CPU
 - Four-channel VoIP DSP
 - Four-channel G.712/V.90 FlexiVoice™ CODEC
 - IPv6 IPsec processor
 - 4-256 QAM receiver with Annex A,B,C FEC
 - 4/16 QAM burst modulator
 - 32-bit 100 MHz SDRAM controller
 - 16-bit expansion bus interface
 - iLine32 32 Mbps HPNA 2.0 phone line networking MAC
 - 10/100 Ethernet MAC with MII
 - 12 Mbps USB 1.1 interface
 - Extensive chip power management
 - 1.8/3.3V -40 to 85c operation
 - 484-pin BGA package

SUMMARY OF BENEFITS

- Designed for primary line and second line cable telephony products
- Expandable to 16+ line MDU applications
- Integrated patented 16-channel DOCSIS/EuroDOCSIS 1.1 PacketSync™ engine obviates VoIP packet delay
- Proprietary software support for enhanced upstream efficiency and performance
- Integrated HomePNA 2.0 MAC supports high speed multimedia services over phone lines
- Available with Certifiable DOCSIS/EuroDOCSIS 1.0/1.1 and CablexChange VoIP Software
- Full IPv6 IPsec module to support advanced applications such as Virtual Private Networking (VPN) and Secure Voice Services
- Included in the comprehensive BCM93352V and BCM93352VCM reference designs
- Integrated CablexChange VoIP/FoIP software
- Full 12 Mbps, USB 1.1 compliant interface to enable simple Plug and Play external PC gateway implementations

BCM3352 Application Block Diagram

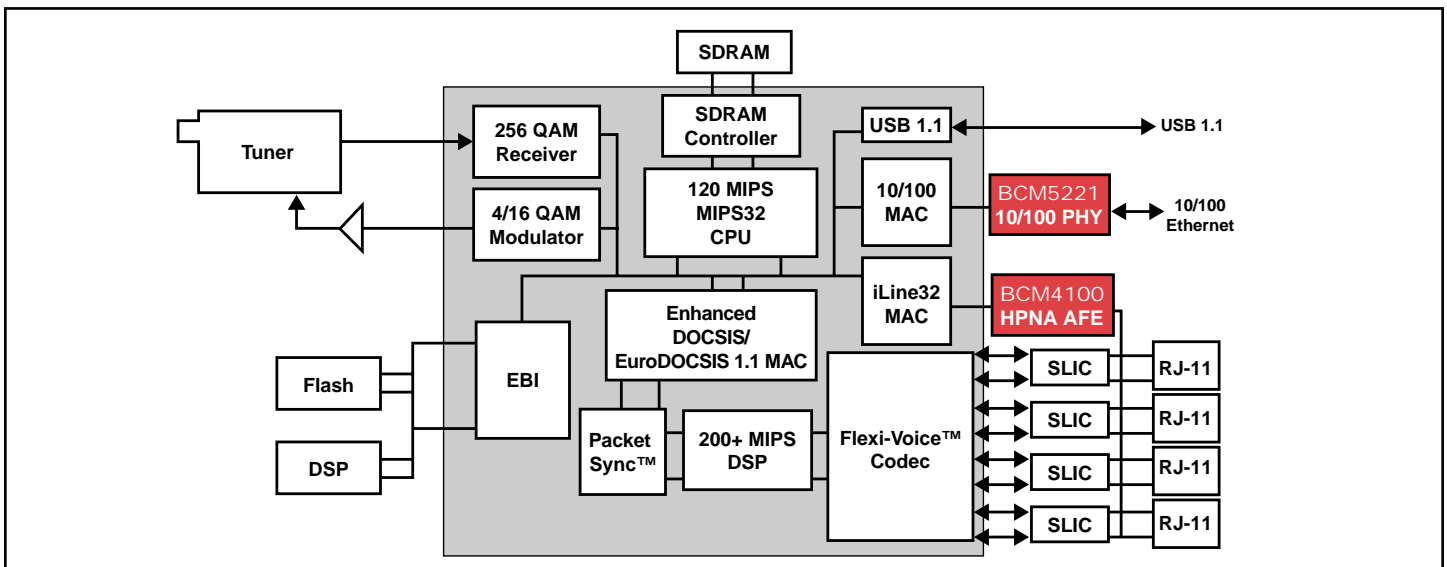

BCM3352 OVERVIEW

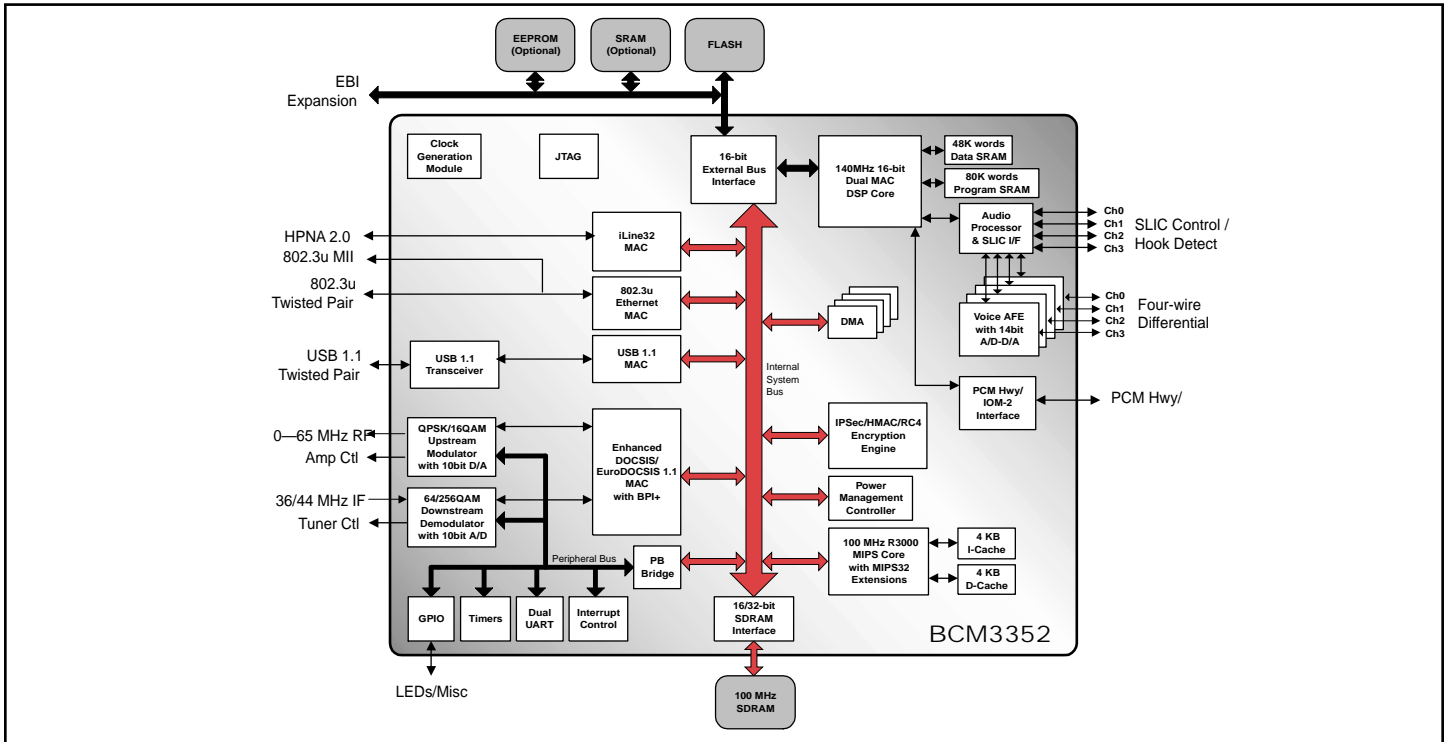

The Broadcom **BCM3352** represents a new and unprecedented level of integration for PacketCable Multimedia Terminal Adapters (MTA.) The BCM3352 provides a unique solution for low power and cost effective MTAs that can deliver primary line VoIP cable telephony and broadband data services over phone lines worldwide.

Key modules integrated in the **BCM3352** include:

- Enhanced VoIP DOCSIS/EuroDOCSIS 1.0/1.1 based MAC integrating a wirespeed DES encryption/decryption engine, full DOCSIS/EuroDOCSIS 1.1 QoS, support for 16 SIDS in the downstream, 256 multicast/and Unicast DA CAM, 16 independent DMA controlled upstream queues, as well as extended network management MIB and diagnostic features.
- 200+ MIPS VoIP/FoIP DSP with patented PacketSync™ delivering four channels of compressed voice packets, including G.711, G.726, G.729a/b/e, and G.728 Vocoders, plus T.38 Fax Relay.
- Integrated iLine32™ HPNA 2.0 home phone line interface that eliminates hundreds of dollars worth of additional telephone and Ethernet wiring.

- High-performance 120 MIPS, 100-MHz MIPS32 processor with a 4K two-way set associative I-cache and a 4K two-way associative D-cache.
- Broadcom Propane™ software support for enhanced bandwidth efficiency and turbo modem performance.
- Integrated 10/100 Ethernet MAC for support of small business integrated access device applications.
- IPsec module with single-DES (CBC & ECB modes), triple-DES (CBC & ECB modes), MD-5 and SHA authentication in hardware, providing support for Virtual Private Networks (VPNs).
- Integrated four-channel FlexiVoice™ Voice Codec with individual line programmable filter coefficients, providing optimum performance for both V.90 modem and voice applications.

Ordering Information:

BCM93352V	Reference Design
BCM93352VCM	Reference Design

Broadcom®, the pulse logo and QAMLink are registered trademarks of Broadcom Corporation and/or its subsidiaries in the United States and certain other countries. iLine32, FlexiVoice, Propane and PacketSync are trademarks of Broadcom Corporation.

For more information please contact us at:
 Phone: 949-450-8700, FAX: 949-450-8710
 Email: info@broadcom.com



Visit our web site at: www.broadcom.com

© 2000 BROADCOM CORPORATION

3352-PB03-R-12.14.00

BROADCOM CORPORATION
 16215 Alton Parkway, P.O. Box 57013
 Irvine, California 92619-7013