



BLUTONIUM® BLUETOOTH® 2.0 + EDR SINGLE-CHIP HCI SOLUTION

FEATURES

- World's first Bluetooth 2.0 + EDR solution in 0.13 um CMOS technology
- Fully integrated balun and T/R switch eliminates all external RF matching components
- Supports class 1, 2, and 3 designs
- Fully supports the Bluetooth 1.1, 1.2, and 2.0 standards including 1, 2, and 3 Mbps EDR operation
- Lowest current consumption in all modes of operation
- ROM-based solution eliminates external flash and/or EEPROM memory
- Highest available Bluetooth radio performance of any single-chip solution
 - 88 dBm receiver sensitivity using EDR communication
 - Programmable output power up to +7 dBm
- Minimized external BOM requirements are less than 10 external passive components
- Supports UART, USB, SDI, and SPI HCI transports
- Fractional-N frequency synthesizer supports any crystal or TCXO source from 12 to 40 MHz
- Automatic calibration and frequency detection of crystal frequency

SUMMARY OF BENEFITS

- Maximizes range and simplifies system integration by providing exceptional output power and receiver sensitivity
- High-level of integration eliminates challenges of board level RF design
- Achieves smallest board area requirements by minimal external BOM and smallest package size available today
 - Standard PCB requirement is less than 50 mm²
 - Module solutions less than 25 mm²
- ROM-based solution with flexible code patching ensures fast integration
- On-chip voltage regulator lowers BOM requirements and provides additional power savings capability
- Minimized power dissipation over other solutions
 - 50% savings in power in standard telephony headset applications
 - 30% savings in power in advanced stereo audio applications

APPLICATIONS

- Cellular and mobile communication devices
- PDA and low-power embedded communication devices
- PC and integration on PC mother board applications
- Package types available
 - 95-pin fpBGA package (6 mm x 6 mm)
 - 65-pin fpBGA package (5 mm x 5 mm)
 - Wafer scale flip chip packaging

Typical Cell Phone Application

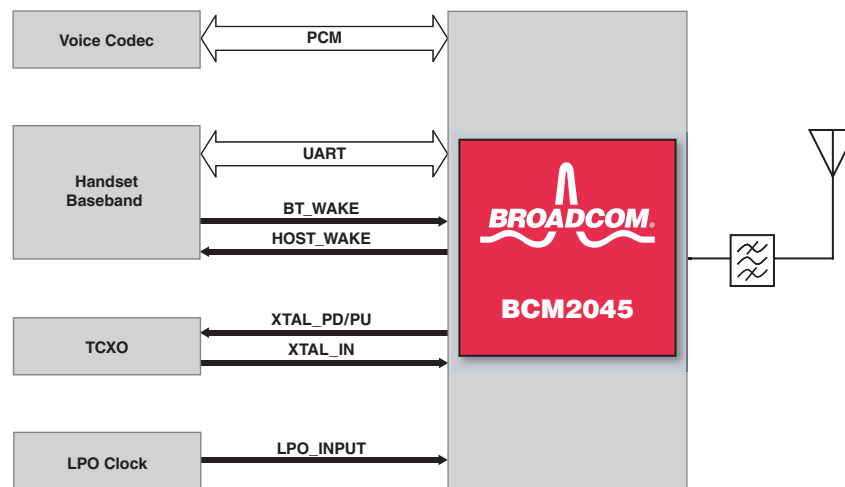

OVERVIEW

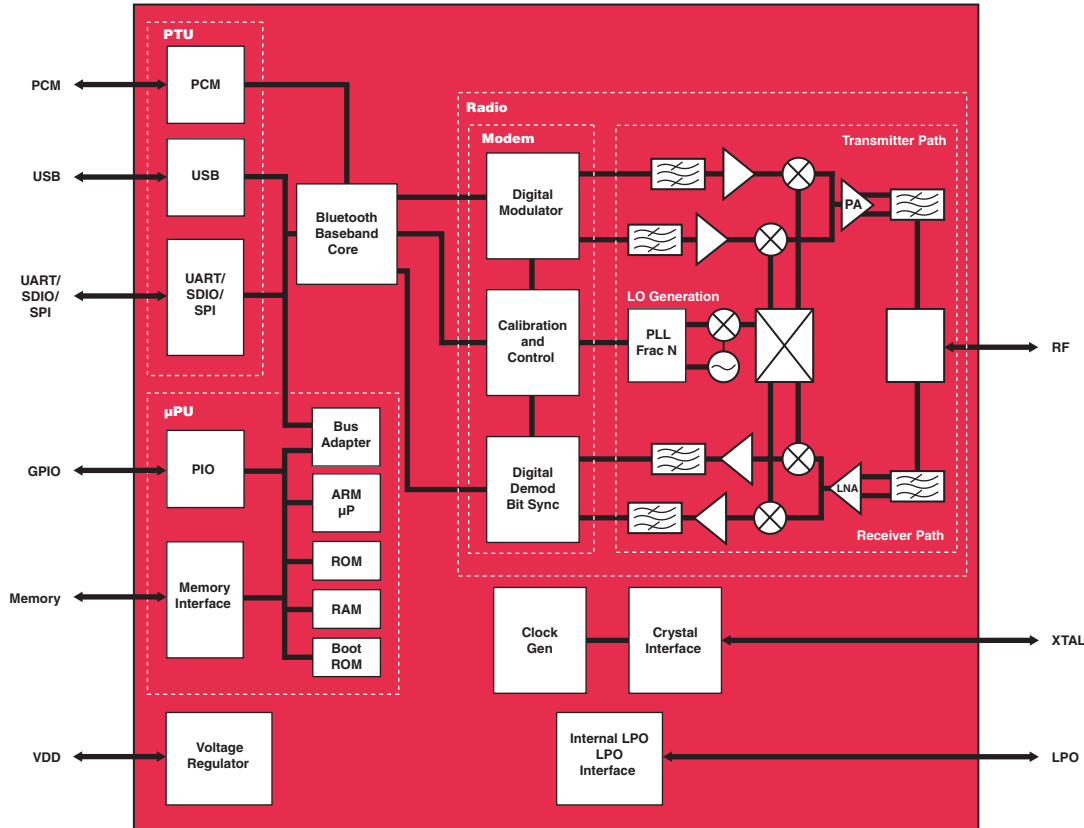

BCM2045 Block Diagram

The Broadcom BCM2045 is a monolithic, single-chip, stand-alone baseband processor with an integrated 2.4-GHz transceiver for Bluetooth 2.0 + EDR applications. It is fully compliant with the Bluetooth specification and completely backward-compatible with any Bluetooth version 1.1 or 1.2-based system. It eliminates the need for external flash memories and active components by integrating critical components into the device, thus minimizing the footprint and system cost of implementing a Bluetooth system.

The BCM2045 EDR solution has been designed in 0.13μ bulk CMOS technology, the most widely available silicon process today. This use of the advanced process enables the BCM2045 to achieve the lowest possible current consumption in all modes of operation and maintain the lowest cost total solution.

The BCM2045 has an architecture that has been designed to take advantage of the EDR standard. Rather than a modification to an existing Bluetooth 1.2 radio, the BCM2045 has been optimized to support

Bluetooth 2.0 + EDR. By designing the radio to take advantage of EDR, higher and more reliable through-and greater-link range performance can be achieved.

Cost optimized solutions can be achieved with the BCM2045 by using standard chip-on-board assembly techniques. Low risk applications are enabled through the extensive integration of external passive and active components. All sensitive RF and analog portions of the Bluetooth radio and baseband have been integrated into the device including the most sensitive high-frequency matching components. This eliminates the possibility of board level interference and degradation in performance due to the environment and board level designs. Internal voltage regulation has been added to eliminate the need for a voltage regulator and the device is capable of operation using a noisy digital 1.8 to 3.6V power supply.

Broadcom[®], the pulse logo, **Connecting everything**[®], the Connecting everything logo, **BroadVoice**[®], and **BroadSAFE**[™] are among the trademarks of Broadcom Corporation and/or its affiliates in the United States, certain other countries and/or the EU. Any other trademarks or trade names mentioned are the property of their respective owners. **Bluetooth**[®] is a trademark of the Bluetooth Sig.

Connecting
everything[®]



BROADCOM CORPORATION
16215 Alton Parkway, P.O. Box 57013
Irvine, California 92619-7013

© 2006 by BROADCOM CORPORATION. All rights reserved.

2045-PB01-R 03/15/06

Phone: 949-450-8700
Fax: 949-450-8710
E-mail: info@broadcom.com
Web: www.broadcom.com