

**0.2A surface mount Schottky diode**

# BAT54C2

**Features**

- High current capability, low forward voltage drop
- High surge current capability
- Guardring for over voltage protection
- Low power loss, high efficiency
- Ultra high-speed switching
- Low profile surface mounted package in order to minimize board space

**Mechanical data**

- Case : Molded plastic, SC-79/SOD523.
- Epoxy : UL94-V0 rated flame retardant
- Terminals : Plated terminals, solderable per MIL-STD-750 method 2026.
- Polarity : Indicated by cathode band.
- Mounting position : Any.

**Symbol**

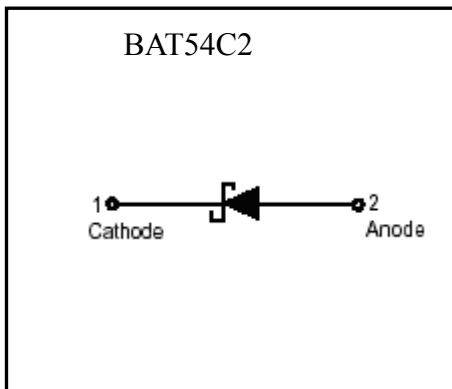

**Outline**

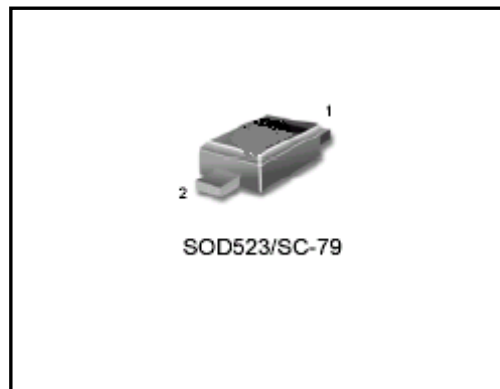

**Ordering Information**

Device	Package	Shipping
BAT54C2-0-T5-G	SOD-523 (Pb-free lead plating and halogen-free package)	8000 pcs / tape & reel

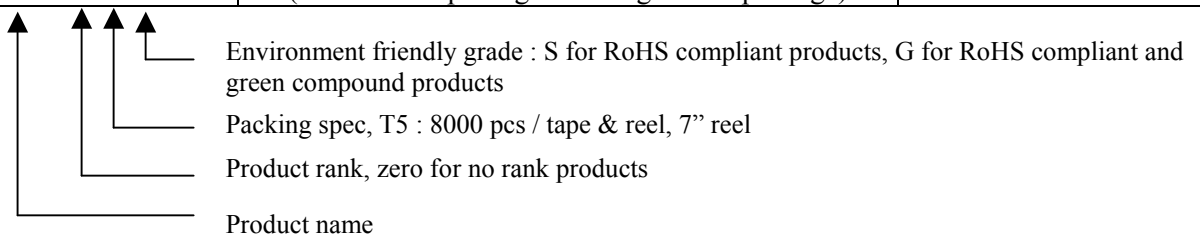



**Absolute Maximum Ratings** (TA=25°C, unless otherwise noted)

Parameters	Conditions	Symbol	Value	Units
Repetitive peak reverse voltage		VRRM	30	V
RMS voltage		VRMS	21	
Continuous reverse voltage		VR	30	
Forward rectified current		IF	0.2	A
Repetitive Peak Forward Current		IFM	0.3	
Non-repetitive Peak Forward Current		IFSM	0.6	
Total Device Dissipation	TA=25°C (Note)	PD	200	mW
Thermal resistance	Junction to Ambient (Note)	RθJA	625	°C/W
Storage temperature range		Tstg	-65 ~ +175	°C
Operating junction temperature range		Tj	-65 ~ +150	°C

Note : When device mounted on FR-5 PCB with minimum pad.

**Characteristics** (TA=25°C)

Characteristic	Symbol	Condition	Min.	Typ	Max.	Unit
Reverse Breakdown Voltage	VBR	IR=100μA	30	-	-	V
Forward Voltage	VF 1	IF=0.1mA	-	-	240	mV
	VF 2	IF=1mA	-	-	320	
	VF 3	IF=10mA	-	-	400	
	VF 4	IF=30mA	-	-	500	
	VF 5	IF=100mA	-	-	800	
Reverse Leakage Current (Note 2)	IR	VR=30V	-	-	2	μA
Diode Capacitance	CD	VR=1V, f=1MHz	-	-	10	pF
Reverse Recovery Time	trr	IF=IR=10mA RL=100Ω measured at IR=1mA	-	-	5	ns

## Typical Characteristics

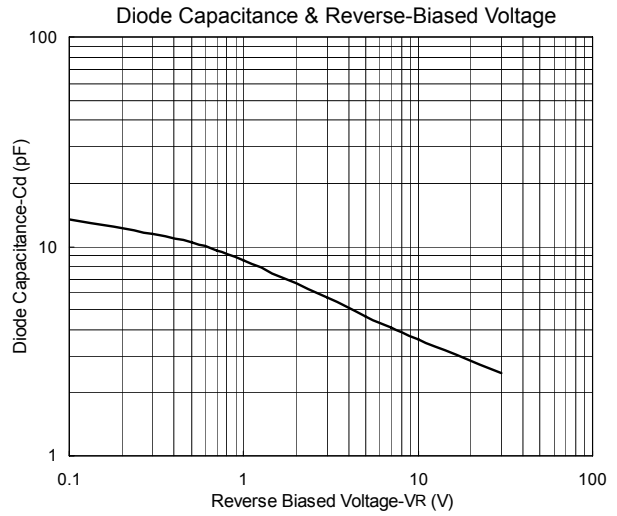
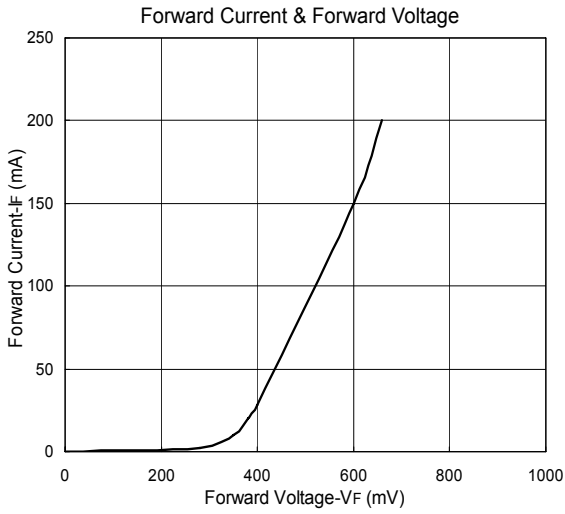

## Recommended Footprint

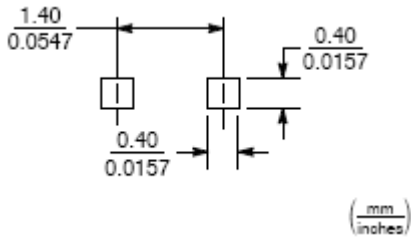

**Reel Dimension**

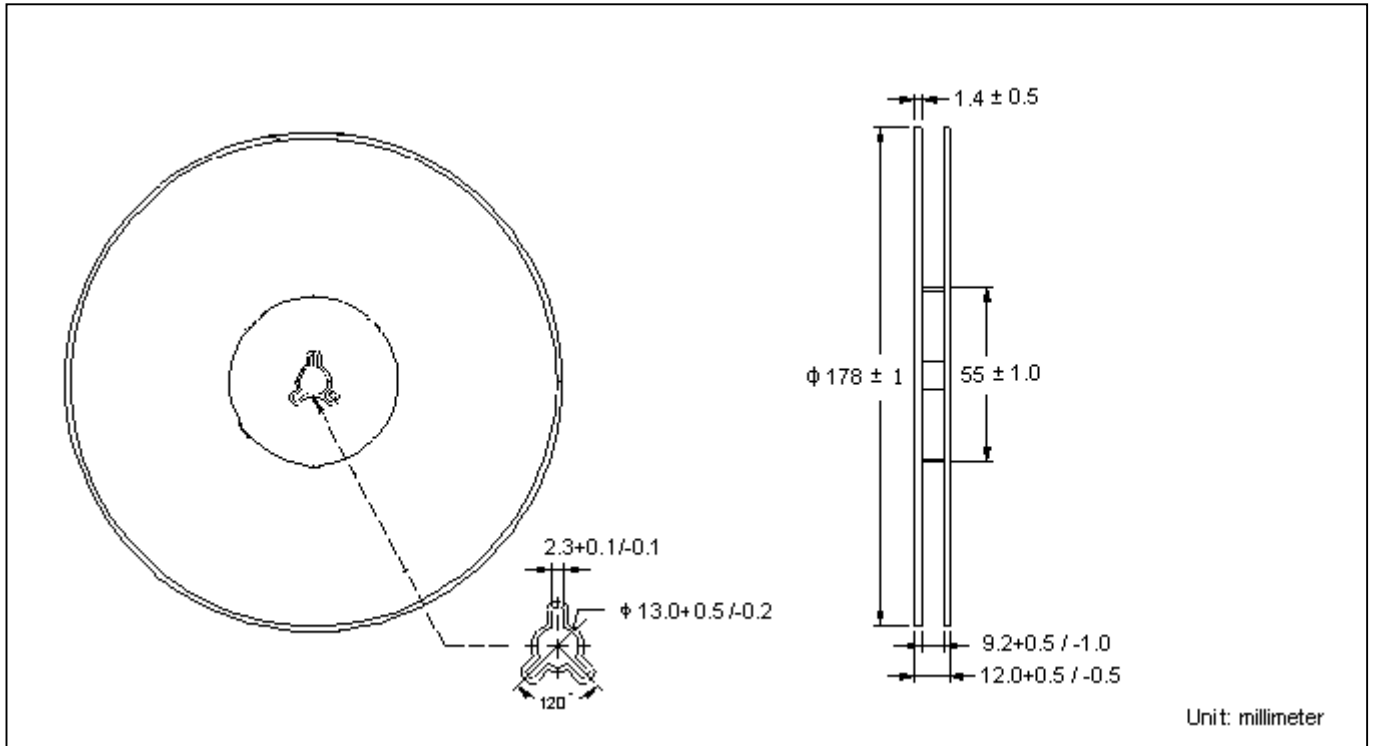

**Carrier Tape Dimension**

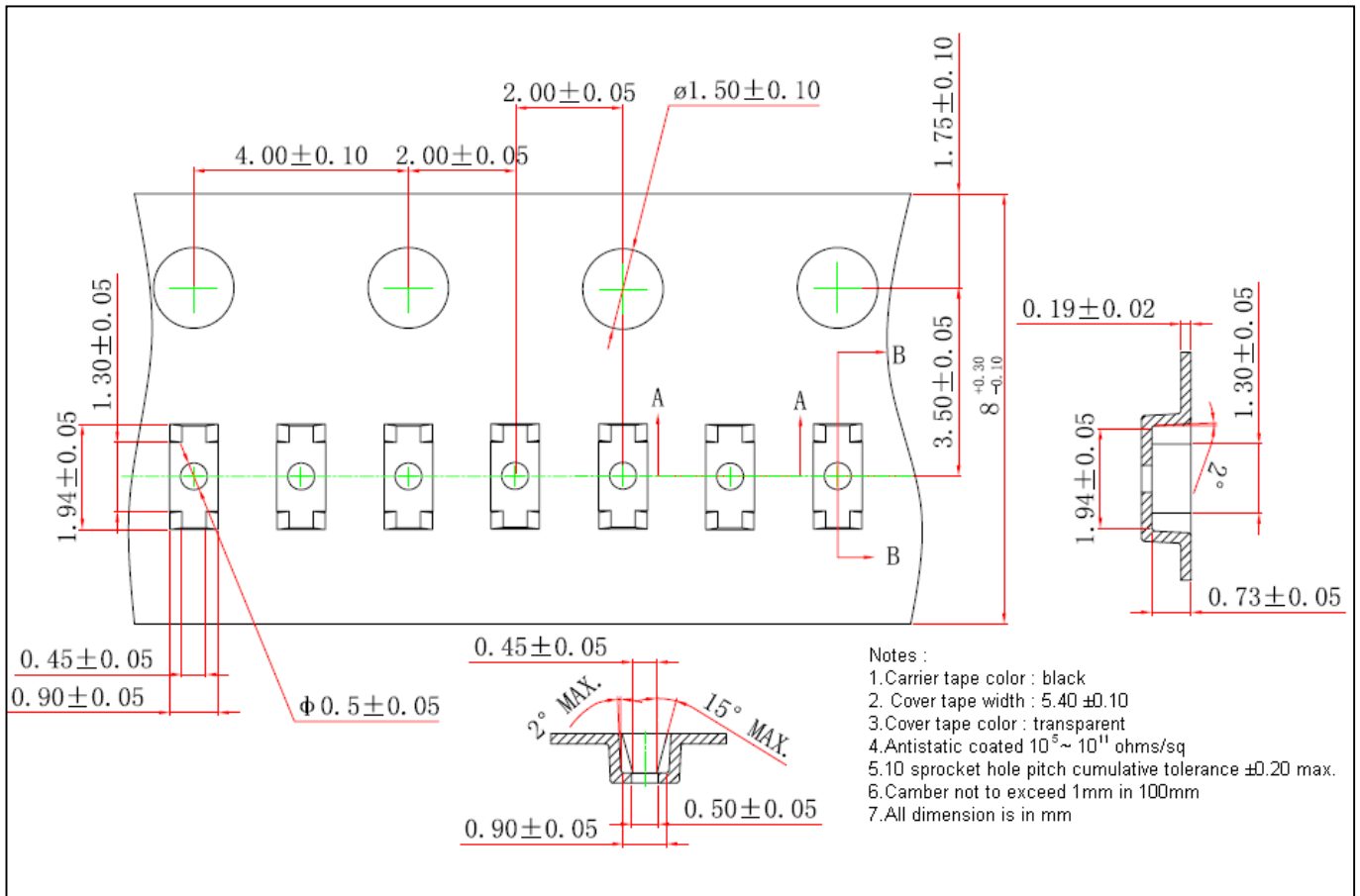

**Recommended wave soldering condition**

Product	Peak Temperature	Soldering Time
Pb-free devices	260 +0/-5 °C	5 +1/-1 seconds

**Recommended temperature profile for IR reflow**

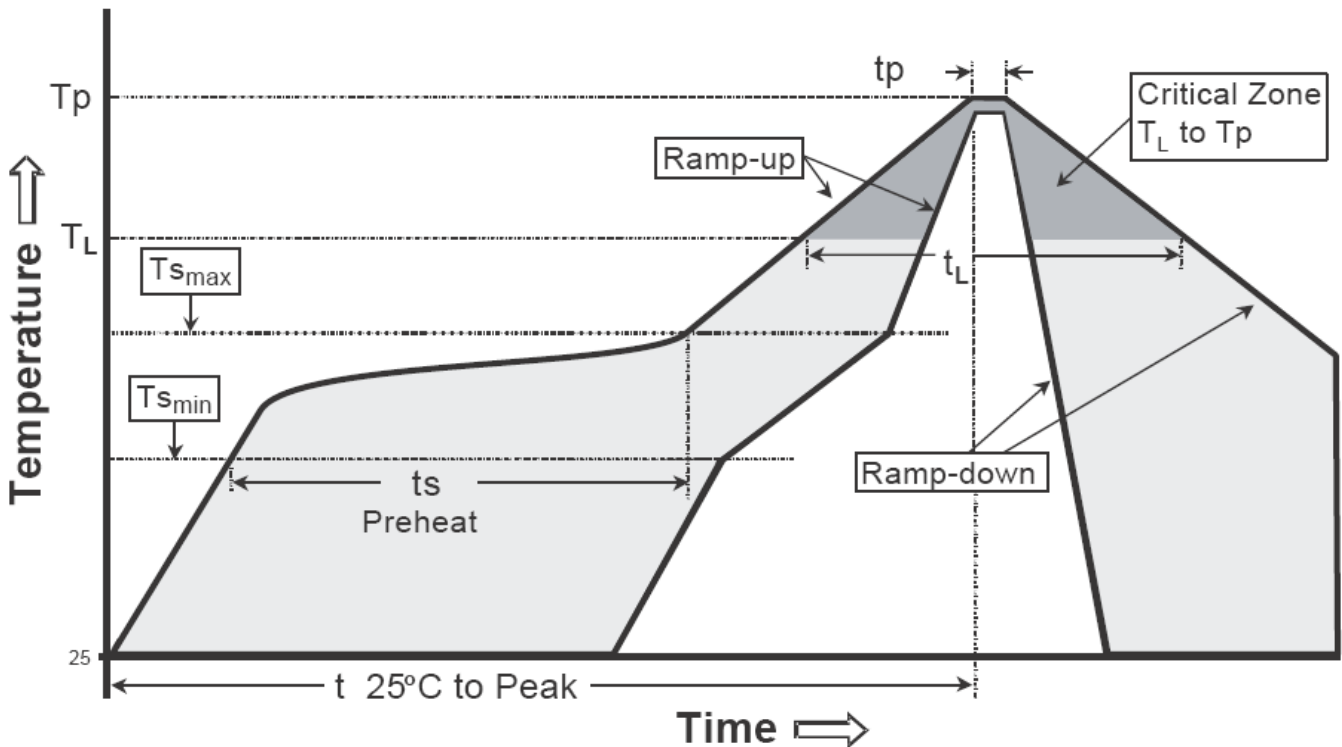

Profile feature	Sn-Pb eutectic Assembly	Pb-free Assembly
Average ramp-up rate (T <sub>smax</sub> to T <sub>p</sub> )	3°C/second max.	3°C/second max.
Preheat		
-Temperature Min(T <sub>s min</sub> )	100°C	150°C
-Temperature Max(T <sub>s max</sub> )	150°C	200°C
-Time(t <sub>s min</sub> to t <sub>s max</sub> )	60-120 seconds	60-180 seconds
Time maintained above:		
-Temperature (T <sub>L</sub> )	183°C	217°C
- Time (t <sub>L</sub> )	60-150 seconds	60-150 seconds
Peak Temperature(T <sub>P</sub> )	240 +0/-5 °C	260 +0/-5 °C
Time within 5°C of actual peak temperature(tp)	10-30 seconds	20-40 seconds
Ramp down rate	6°C/second max.	6°C/second max.
Time 25 °C to peak temperature	6 minutes max.	8 minutes max.

Note : All temperatures refer to topside of the package, measured on the package body surface.

**SOD-523 Dimension**

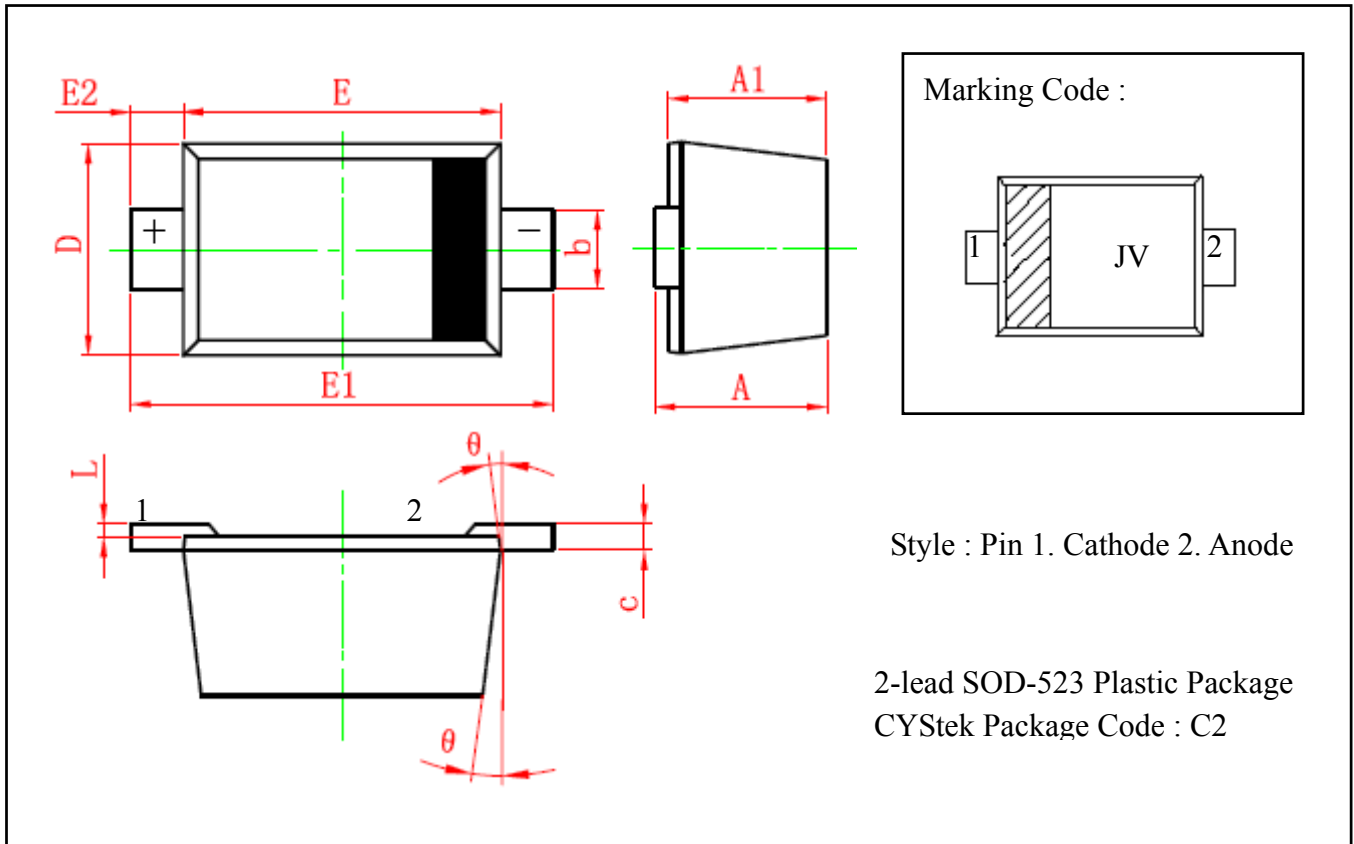

\*: Typical

DIM	Millimeters		Inches		DIM	Millimeters		Inches	
	Min.	Max.	Min.	Max.		Min.	Max.	Min.	Max.
A	0.510	0.770	0.020	0.031	E	1.100	1.300	0.043	0.051
A1	0.500	0.700	0.020	0.028	E1	1.500	1.700	0.059	0.067
b	0.250	0.350	0.010	0.014	E2	0.200	REF	0.008	REF
c	0.080	0.150	0.003	0.006	L	0.010	0.070	0.001	0.003
D	0.750	0.850	0.030	0.033	$\theta$	7° REF		7° REF	

Notes: 1. Maximum lead thickness includes lead finish thickness, and minimum lead thickness is the minimum thickness of base material.  
 2. If there is any question with packing specification or packing method, please contact your local CYStek sales office.

**Material:**

- Lead: Pure tin plated.
- Mold Compound: Epoxy resin family, flammability solid burning class: UL94V-0.

**Important Notice:**

- All rights are reserved. Reproduction in whole or in part is prohibited without the prior written approval of CYStek.
- CYStek reserves the right to make changes to its products without notice.
- CYStek **semiconductor products are not warranted to be suitable for use in Life-Support Applications, or systems.**
- CYStek assumes no liability for any consequence of customer product design, infringement of patents, or application assistance.